



# District Laboratory Practice in Tropical Countries

SECOND EDITION

**PART 2**

MONICA CHEESBROUGH

This page intentionally left blank

# **District Laboratory Practice in Tropical Countries**

**Part 2**

**Second Edition**

**Monica Cheesbrough**



**CAMBRIDGE**  
UNIVERSITY PRESS

CAMBRIDGE UNIVERSITY PRESS

Cambridge, New York, Melbourne, Madrid, Cape Town, Singapore, São Paulo

Cambridge University Press

The Edinburgh Building, Cambridge CB2 8RU, UK

Published in the United States of America by Cambridge University Press, New York

[www.cambridge.org](http://www.cambridge.org)

Information on this title: [www.cambridge.org/9780521676311](http://www.cambridge.org/9780521676311)

© Monica Cheesbrough 2000, 2006

This publication is in copyright. Subject to statutory exception and to the provision of relevant collective licensing agreements, no reproduction of any part may take place without the written permission of Cambridge University Press.

First published in print format 2006

ISBN-13 978-0-511-34842-6 eBook (EBL)

ISBN-10 0-511-34842-8 eBook (EBL)

ISBN-13 978-0-521-67631-1 paperback

ISBN-10 0-521-67631-2 paperback

Cambridge University Press has no responsibility for the persistence or accuracy of urls for external or third-party internet websites referred to in this publication, and does not guarantee that any content on such websites is, or will remain, accurate or appropriate.

Every effort has been made in preparing this book to provide accurate and up-to-date information which is in accord with accepted standards and practice at the time of publication. Nevertheless, the authors, editors and publisher can make no warranties that the information contained herein is totally free from error, not least because clinical standards are constantly changing through research and regulation. The authors, editors and publisher therefore disclaim all liability for direct or consequential damages resulting from the use of material contained in this book. Readers are strongly advised to pay careful attention to information provided by the manufacturer of any drugs or equipment that they plan to use.

# Part 2

# Contents

## Chapter 7 Microbiological tests

7.1	Microbiology practice and quality assurance in district laboratories	Pages 1–9
7.2	Features and classification of microorganisms of medical importance	9–35
7.3	Microscopical techniques used in microbiology	35–45
7.4	Culturing bacterial pathogens	45–62
7.5	Biochemical tests to identify bacteria	62–70
7.6	Examination of sputum	71–76
7.7	Examination of throat and mouth specimens	76–79
7.8	Examination of pus, ulcer material and skin specimens	80–85
7.9	Examination of effusions	85–90
7.10	Examination of urogenital specimens	90–97
7.11	Examination of faecal specimens	97–105
7.12	Examination of urine	105–115
7.13	Examination of cerebrospinal fluid (c.s.f.)	116–124
7.14	Culturing blood	124–130
7.15	Examination of semen	130–132
7.16	Antimicrobial susceptibility testing	132–143
7.17	Water-related diseases and testing of water supplies	143–157
7.18	Summary of the clinical and laboratory features of microorganisms	
	Bacterial pathogens	157–234
	Fungal pathogens	234–247
	Viral pathogens	248–266

**COLOUR SECTION** ..... between p. 266 and p. 267

## Chapter 8 Haematological tests

8.1	Haematology in district laboratories and quality assurance	268–271
8.2	Functions of blood, haematopoiesis and blood disorders	271–295
8.3	Collection of blood	295–299
8.4	Measurement of haemoglobin	299–309
8.5	PCV and red cell indices	309–313
8.6	Counting white cells and platelets	313–319
8.7	Blood films	319–329
8.8	Erythrocyte sedimentation rate	329–331
8.9	Reticulocyte count. Methaemoglobin reduction test	331–334
8.10	Investigation of sickle cell disease	334–340
8.11	Investigation of bleeding disorders	340–347

## Chapter 9 Blood transfusion tests

9.1	Blood transfusion services at district level and quality assurance	348–351
9.2	Blood donation and storage of blood	352–361
9.3	Blood grouping	362–369
9.4	Compatibility testing	369–378

**Recommended Books** ..... 379

**Details of Part 1** ..... 380

## Appendix I

Preparation of reagents and culture media ..... 382–407

## Appendix II

Useful addresses ..... 410–416

**Index** ..... 417–434

# Preface

Since the publication of the first edition of Part 2 *District Laboratory Practice in Tropical Countries* in 2000, the work of many district laboratories continues to be dominated by the on-going HIV/AIDS pandemic, increases in the prevalence of tuberculosis and other HIV-related infections and more recently, the requirement for laboratory monitoring of antiretroviral therapy.

This new edition includes an update on HIV disease/AIDS, recently developed HIV rapid tests to diagnose HIV infection and screen donor blood, and current information on antiretroviral drugs and the laboratory monitoring of antiretroviral therapy.

Information on the epidemiology and laboratory investigation of other pathogens has also been brought up to date. Several new, rapid, simple to perform immunochromatographic tests to assist in the diagnosis of infectious diseases are described, including those for brucellosis, cholera, dengue, leptospirosis, syphilis and hepatitis. Recently developed IgM antibody tests to investigate typhoid fever are also described. The new classification of salmonellae has been introduced.

Details of manufacturers and suppliers now include website information and e-mail addresses. Websites are also included that provide up to date information on water and sanitation initiatives, and diseases such as tuberculosis, cholera, leptospirosis, mycetoma, HIV/AIDS and other sexually transmitted infections.

Where required the haematology and blood transfusion chapters have been updated, including a review of haemoglobin measurement methods in consideration of the high prevalence of anaemia in developing countries.

It is hoped that this new edition of Part 2 and recently published second edition of Part 1 *District Laboratory Practice in Tropical Countries* will continue to help and motivate those working in district laboratories and those responsible for the management of district laboratory services, training and continuing education of district laboratory personnel.

Monica Cheesbrough, November 2005

# Acknowledgements

The author wishes to thank all those who have corresponded and contributed their suggestions for this second edition Part 2 *District Laboratory Practice in Tropical Countries*, particularly those working in district laboratories and training laboratory personnel in tropical and developing countries.

Gratitude and thanks are also due to those who have helped to prepare the new edition:

Mr Steven Davies, Microbiology Specialist Advisor, Institute of Biomedical Sciences (IBMS) for reading through and commenting on the microbiology chapter and contributing text on antimicrobials and the *Etest*. Also acknowledged for their suggestions are Mr Stephen Mortlock, Member of the IBMS Microbiology Advisory Panel and Mr Mark Tovey, Microbiology Department, Sheffield.

Mr Simon Hardy, Senior Lecturer in Microbiology, University of Brighton, for also assisting in the revision of the microbiology chapter.

Dr Eric Bridson, Microbiologist, for reading through the text and checking microbial nomenclature.

Dr Mohammed Tofiq, NMK Clinic, for corresponding with the author and making suggestions for the microbiology text.

In the preparation of the text covering laboratory monitoring of antiretroviral therapy, gratitude is expressed to Dr Jane Carter, AMREF, Nairobi, Dr Steve Gerrish, Kara Clinic, Lusaka, Major Peter Disney, Tshelanyemba Hospital, Zimbabwe and Mr Derryck Klarkowski, Laboratory Specialist, Médecins Sans Frontières, for their helpful contributions.

Dr Henk Smits, Molecular Biologist, Biomedical Research Royal Tropical Institute, Amsterdam, for supplying information on rapid tests for brucellosis and leptospirosis.

Professor Asma Ismail, Director Institute for Research in Molecular Medicine, University Sains Malaysia, for providing text and artwork for the *Typhirapid* test.

Ms M Marilyn Eales, Haematology Tutor, Pacific Paramedical Training Centre, Wellington, New Zealand, for reading through and commenting on the haematology and blood transfusion chapters.

The author also wishes to thank Fakenham Photosetting for their careful and professional preparation of the new edition.

*Acknowledgements for colour artwork:* These can be found on page 267.





## 7

# Microbiological tests

## 7.1 Microbiology practice and quality assurance in district laboratories

In tropical and developing countries, there is an urgent need to strengthen clinical microbiology and public health laboratory services in response to:

- The high prevalence and increasing incidence of infectious diseases.

HIV disease/AIDS, acute respiratory tract infections (particularly pneumonia), typhoid, cholera, dysentery, tuberculosis, meningitis, whooping cough, plague, sexually transmitted diseases (including gonorrhoea and syphilis), viral hepatitis, yellow fever, dengue, and viral haemorrhagic fevers are major infectious diseases that cause high mortality and serious ill health in tropical and developing countries. Climatic changes, particularly global warming and extreme rainfall, are increasing the distribution of some infectious diseases, especially those that are mosquito-borne and water-borne.

- The threat posed by the re-emergence and rapid spread of diseases previously under control or in decline such as tuberculosis, plague, diphtheria, dengue, cholera and meningococcal meningitis.
- The emergence of opportunistic pathogens associated with HIV, new strains of pathogens such as *Vibrio cholerae* serotype 0139 and viruses causing severe acute respiratory syndrome (SARS) and avian influenza.
- The rapid rate at which bacterial pathogens are becoming resistant to commonly available and affordable antimicrobials.

Drug resistance is causing problems in the treatment and control of infections caused by pathogens such as *Streptococcus pneumoniae*, *Haemophilus influenzae*, *Staphylococcus aureus*, *Pseudomonas aeruginosa*, *Neisseria gonorrhoeae*, and enterococci. Some strains of *M. tuberculosis* have developed multi-drug resistance.

- The need for reliable microbiological data to

develop and validate standard treatments and control interventions, and ensure antimicrobial drugs are purchased appropriately and used correctly.

Infections are particularly prevalent where poverty, malnutrition, and starvation are greatest, sanitation is inadequate, personal hygiene poor, water supplies are unsafe or insufficient, health provision the least developed, and disease control measures are lacking or ineffective.

War and famine in developing countries have greatly increased the number of people that have become refugees, suffer illhealth and die prematurely from infectious diseases.

In rural areas, distances to health centres and hospitals are often too great to be travelled by patients or mothers with young children requiring immunization.

In many countries, increasing urbanization has resulted in an increase in the incidence of diseases associated with inadequate and unsafe water, poor sanitation, and overcrowded living conditions.

In areas of high HIV prevalence, major pathogens such as *M. tuberculosis* and *Streptococcus pneumoniae* and a range of opportunistic pathogens associated with immunosuppression, are responsible for infections, often life-threatening, in those infected with HIV.

This subunit includes information on:

- Clinical microbiology and public health laboratory activities at district level.
- Quality assurance and standard operating procedures (SOPs) in microbiology.
- Collection of microbiological specimens.
- Safe working practices.

### CLINICAL MICROBIOLOGY AND PUBLIC HEALTH LABORATORY ACTIVITIES AT DISTRICT LEVEL

A network of district microbiology and regional public health laboratories is needed to provide to the community, accessible microbiological services.

*Important:* District laboratories require the support of the regional public health laboratory in the preparation and implementation of microbiological standard operating procedures (SOPs), safe working practices, on-site training, quality assurance, and provision of essential supplies (e.g. reagents, culture media, controls, antisera).

### **Operating microbiological laboratory services with minimal resources**

The high cost of culture media and reagents, lack of a rational approach to the selection and use of microbiological investigations, and a shortage of trained technical staff and clinical microbiologists are important factors in preventing the establishment and extension of essential microbiological services in developing countries.

To ensure the optimal use of available resources, it is important for health authorities to identify those pathogens of greatest public health importance

which require microbiological investigations based on a consideration of:

- local disease patterns,
- clinical relevance and frequency of isolation,
- severity of disease and outcome,
- possibility of effective intervention,
- need for surveillance to monitor drug resistance and epidemic potential,
- cost benefit ratio of isolation and, or, identification,
- laboratory capacity and resources available,
- availability of trained personnel to perform microbiological investigations and ensure the quality of work and reports.

Such an approach helps to target resources where they are most needed, enables a list of essential culture media and diagnostic reagents to be identified, sourced and costed, and training in microbiology techniques and their application to be more specific.

### **Providing appropriate, reliable and affordable microbiological services**

Laboratory personnel, clinicians, community health officers and sanitary officers must work closely together in deciding the microbiological services that are required and ensuring the services provided are appropriate, reliable, and affordable.

This involves *identifying*:

- The infectious diseases that require laboratory investigation (priority pathogens).
- Role of district laboratories in surveillance work and the investigation of epidemics.
- Techniques (SOPs) to be used to collect specimens, identify pathogens and perform antimicrobial susceptibility tests.
- Most appropriate systems for reporting and recording the results of microbiological investigations, collating and presenting data for surveillance purposes.
- Quality assurance.
- Training requirements, supervision, and on-going professional support.
- Equipment and microbiological supplies needed and systems for distribution of supplies.
- Costs involved.

### **QUALITY ASSURANCE AND SOPs IN MICROBIOLOGY**

The principles of quality assurance (QA) and general guidelines on how to prepare standard operating procedures (SOPs) are described in subunit 2.4 in Part 1 of the book.

#### **Need for quality assurance and SOPs in microbiology**

Microbiological investigations are important in the diagnosis, treatment, and surveillance of infectious diseases and policies regarding the selection and use of antimicrobial drugs. It is therefore essential that test reports:

- are reliable,
- standardized,
- provide the information that is required at the time it is needed,
- in a form that can be understood.

Quality assurance is also required to minimize waste and ensure investigations are relevant and used appropriately.

WHO in its publication *Basic laboratory procedures in clinical bacteriology*<sup>1</sup> states that quality assurance in microbiology must be:

- *comprehensive*: to cover every step in the cycle from collecting the specimen to sending the final report to the doctor as shown opposite;

- *rational*: to concentrate on the most critical steps in the cycle;
- *regular*: to provide continuous monitoring of test procedures;
- *frequent*: to detect and correct errors as they occur.

The following apply to the QA of the pre-analytical, analytical, and post-analytical stages of microbiological procedures and should be incorporated in microbiological SOPs.

### Pre-analytical stage

SOPs need to describe:

- Selection and appropriate use of microbiological investigations.
- Collection and transport of specimens.
- How to fill in a request form correctly.
- Checks to be made when the specimen and request form reach the laboratory.

### Appropriate use of microbiological investigations

This aspect of QA requires collaboration between laboratory personnel, clinicians, and public health officers as discussed at the beginning of this subunit. The fewer the resources the more important it is to establish priorities based on clinical and public health needs. Clear guidelines should be provided on the use and value of specific microbiological investigations.

*Collection and transport of microbiological specimens*  
Specimens for microbiological investigation *must* be collected correctly if pathogens are to be successfully isolated and identified, reports are not to be misleading, and resources are not to be wasted. Written instructions for the collection of specimens must be issued by the laboratory to all those responsible for collecting microbiological specimens. The collection of microbiological specimens is described at the end of this subunit.

### Request form

Each specimen must be accompanied by a request form which details:

- the patient's name, age (whether an infant, child, adult), gender, outpatient or inpatient number, ward or health centre, and home area/village.
- type and source of specimen, and the date and time of its collection.
- investigation(s) required.
- clinical note summarizing the patient's illness, suspected diagnosis and information on *any antimicrobial treatment* that may have been started at home or in the hospital.

*Note:* The clinical note will help to report usefully the results of laboratory investigations.

- name of the medical officer requesting the investigation.

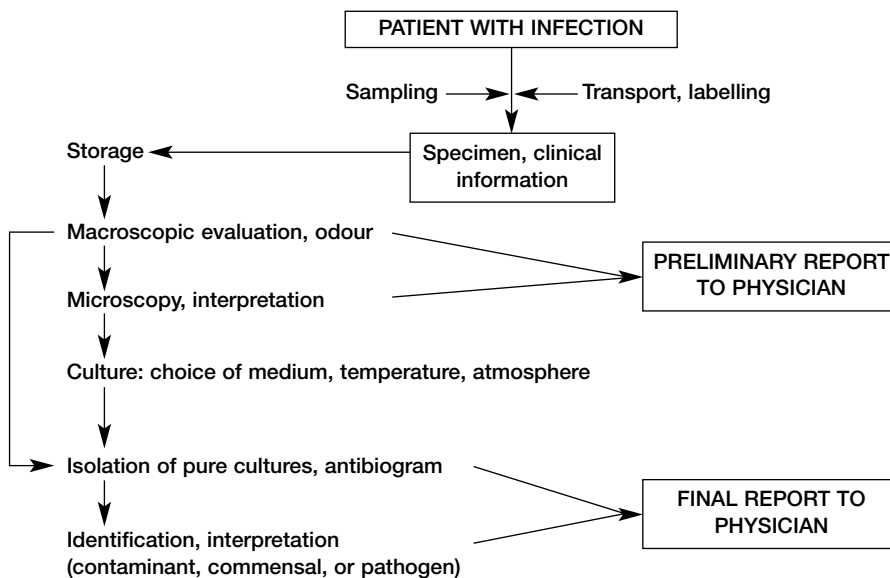

Steps in the laboratory investigation of an infected patient.

Reproduced from *Basic Laboratory procedures in clinical bacteriology*, 2nd edition, 2003, World Health Organization.

*Checking a specimen and request form*

SOPs should include the procedures to be followed when specimens reach the laboratory, particularly checks to ensure that the correct specimen has been sent and the name on the specimen is the same as that on the request form. Also included should be how to handle and store specimens that require immediate attention, e.g. c.s.f., blood cultures, unpreserved urine, swabs not in transport media, faecal specimens containing blood and mucus, and wet slide preparations.

Examples of specimens which should not be accepted for microbiological investigations include:

- dry faecal swabs,
- saliva instead of sputum,
- eye swabs that have not been freshly collected,
- any specimen not collected into a correct container,
- a leaking specimen (sample may be contaminated).

**Analytical stage**

The following should be included in microbiological SOPs, covering the analytical stage:

- Detailed procedures for examining different specimens (described in subsequent subunits).
- Staining techniques and quality control (QC) of stains (see following text).
- Aseptic techniques and safe handling of infectious material as described in subunit 7.4.
- Preparation and QC of culture media and preservation of stock strains used in performance testing (see subunit 7.4).
- Inoculation of broth and agar culture media and plating out techniques (see subunit 7.4).
- Reading and interpretation of cultures (see subunit 7.4).
- Techniques used to identify pathogens and the QC of diagnostic reagents, strips, and discs as described in subunit 7.5.
- Antimicrobial susceptibility testing and QC of procedure and discs as described in subunit 7.16.
- Cleaning and QC of equipment used in the microbiology laboratory, e.g. microscope, incubator, anaerobic jar, centrifuge, waterbath/heat block, autoclave, hot-air oven, and refrigerator (see following text).
- Immunological techniques and QC of antigen and antibody reagents.
- Safe working practices (see end of this subunit).

- Disposal of specimens and cultures (see subunit 3.4 in Part 1 of the book).
- Cleaning of glassware, plasticware, etc (described in subunits 3.4 and 3.6 in Part 1 of the book).
- Sterilization procedures and their control (see subunits 3.4 and 4.8 in Part 1 of the book).  
The sterilization of glassware by dry heat is described in subunit 7.4.

*Important:* As part of QC, the performance of staff must be monitored, all techniques must be demonstrated to new members of staff, the results of QC tests must be recorded and signed, and the work of newly qualified staff supervised (see also subunit 2.4 in Part 1 of the book).

*Control of stains and reagents*

All stains and reagents must be clearly labelled, dated, and stored correctly. The preparation, fixation, staining and reporting of smears as detailed in the department's SOPs must be followed exactly. Stains and reagents should not be used beyond their expiry date (where this applies) or when they show signs of deterioration such as abnormal turbidity or discoloration.

At regular intervals and whenever a new batch of stain is prepared, e.g. basic fuchsin in the Ziehl-Neelsen technique or crystal violet in the Gram technique, control smears of appropriate organisms should be stained to ensure correct staining reactions. Control smears used in the Ziehl-Neelsen technique should include smears with few to moderate numbers of AFB. Smears for controlling Gram staining can be prepared from a mixed broth culture of staphylococci and *Escherichia coli*. All control smears should be alcohol-fixed and stored in labelled, dated, airtight containers.

Use efficient (non-leaking), preferably light-proof stain dispensing containers to avoid stains being wasted. Ensure containers can be closed when not in use to avoid evaporation and contamination of stains.

A common cause of poor staining is attempting to stain a smear that is too thick, e.g. c.s.f. containing many pus cells. When a smear is too thick, the decolorization process is often incomplete which can result in Gram negative organisms being reported as Gram positive. The QC of reagents used in biochemical diagnostic tests is described in subunit 7.5.

*Control of equipment*

For each item of equipment there should be clear operating and cleaning instructions, and service sheets. Regular cleaning, servicing and maintenance

are essential if equipment is to remain in good working order and safe to use.

The operating temperature of a refrigerator, incubator, heat block and water-bath should be monitored and charted daily. Regular checks should also be made of all glassware and reusable plastic items to ensure that they are completely clean, not damaged, and being sterilized correctly. Specimen containers should be inspected regularly, especially the caps of bottles and tubes for missing or worn liners.

The use, care, maintenance, and performance checks of microscopes are described in subunit 4.3 and of other items of equipment in subunits 4.4–4.12 in Part 1 of the book. Hazards associated with the use of equipment and glassware are covered in subunit 3.6 in Part 1. The use and control of an autoclave are described in subunits 3.4 and 4.8, also in Part 1. The use and control of anaerobic jars are covered in subunit 7.4.

### Post-analytical stage

SOPs need to include:

- Reporting and verifying of microbiological test results.
- Taking appropriate action(s) when a result has serious patient or public health implications.
- Interpreting test reports correctly.

### Reporting results

The terminology and format used in reporting microscopic preparations, cultures, and antimicrobial susceptibility tests should be standardized and agreed between laboratory personnel, clinicians, and public health officers. Any preliminary report of microscopical findings or isolation of a pathogen from a primary culture must be followed by a full written report.

All reports must be concise and clearly presented. The use of rubber stamps can be helpful in standardizing the report and making it easy to understand, e.g. stamps that list the presence or absence of recognized pathogens or that list the antibiotics against which an isolate has been tested. When using a stamp, care must be taken to position it correctly and sufficient ink must be used to reproduce clearly the entire stamp. The reporting of cultures is discussed in subunit 7.4.

### Verifying and interpreting reports

Before leaving the microbiology laboratory, all reports must be checked for correctness and clarity and signed by the person in charge of the department. Reports which are urgently needed for patient

care or the management of an epidemic must reach the clinician or public health officer/epidemiologist as soon as possible. Those receiving the reports should consult the laboratory when any part of the report is unclear. Improvement in the quality and usefulness of microbiological reports will only be achieved by effective communication between those requesting tests and laboratory staff.

A record of the results of all investigations must be kept by the laboratory, e.g. as carbon copies, work sheets, or in record books. Copies of work sheets should be dated and filed systematically each day.

### External quality assessment

Whenever possible the regional public health laboratory should organize an external quality assessment (EQA) scheme to help district microbiology laboratories. An EQA scheme should include testing for major pathogens. It should not be too complicated, costly, or time-consuming for district laboratories.

The main objective of an EQA scheme is to confirm that a laboratory's SOPs and internal QC procedures are working satisfactorily. EQA schemes help to identify errors, improve the quality of work, stimulate staff motivation, and assure users of the service that the laboratory is performing to the standard required to provide reliable results.

WHO advises that an EQA scheme should operate monthly or at least four times a year. Instructions and a report form (to be returned with results after 1 week) should be sent with the specimens to each participating laboratory. Each specimen should be examined in the same way as routine clinical samples (not recognized as a QC specimen). The District Laboratory Coordinator should investigate and assist any poor performing laboratory and where indicated, arrange for the further training of staff. Refresher courses should be held periodically to maintain competence and motivation and to introduce new tests.

*Note: An excellent chapter on quality assurance in microbiology can be found in the WHO publication *Basic laboratory procedures in clinical bacteriology*.<sup>1</sup>*

### COLLECTION OF MICROBIOLOGICAL SPECIMENS

The value and reliability of microbiological reports are directly affected by the quality of the specimen received by the laboratory and the length of time between its collection and processing.

The collection of specimens must form part of the department's SOPs (see previous text), and the laboratory should issue written instructions to all

those responsible for the collection of specimens from inpatients and outpatients. Such instructions should include:

- The amount and type of specimen required, container to use, and need for any preservative or transport medium.
- Best time to collect a specimen.
- Aseptic and safe methods of collection to avoid contamination and accidental infection.
- Labelling of the specimen container.
- Conditions in which specimens need to be kept prior to and during their transport to the laboratory.
- Arrangements for processing specimens that are urgent and those collected outside of normal working hours, e.g. blood cultures collected by medical staff.

### Type of specimen

The correct type of specimen to collect will depend on the pathogens to be isolated, e.g. a cervical not a vaginal swab is required for the most successful isolation of *N. gonorrhoeae* from a woman. Sputum not saliva is essential for the isolation of respiratory pathogens.

### Time of collection

Specimens such as urine and sputum are best collected soon after a patient wakes when organisms have had the opportunity to multiply over several hours. Blood for culture is usually best collected when a patient's temperature begins to rise. The time of collection for most other specimens will depend on the condition of the patient, and the times agreed between the medical, nursing, and laboratory staff for the delivery of specimens to the laboratory.

*Important:* Every effort must be made to collect specimens for microbiological investigation *before* antimicrobial treatment is started and to process specimens as soon after collection as possible.

### Collection techniques

Detailed instructions on how to collect different specimens can be found in the subsequent subunits of this chapter.

The following apply to the collection of most microbiological specimens:

- Use a collection technique that will ensure a specimen contains only those organisms from the site where it was collected. If contaminating organisms are introduced into a specimen

during its collection or subsequent handling, this may lead to difficulties in interpreting cultures and delays in issuing reports.

A strictly sterile (aseptic) procedure is essential when collecting from sites that are normally sterile, e.g. the collection of blood, cerebrospinal fluid, or effusions. An aseptic technique is necessary not only to prevent contamination of the specimen but also to protect the patient.

- Avoid contaminating discharges or ulcer material with skin commensals. The swabs used to collect the specimens must be sterile and the absorbent cotton-wool from which the swabs are made must be free from antibacterial substances.
- Collect specimens in sterile, easy to open, leak-proof, dry containers, free from all traces of disinfectant. Containers must be clean but need not be sterile for the collection of faeces and sputum.

To avoid breakages, whenever possible, containers made from autoclavable plastic should be used providing these are leak-proof.\*

\*Autoclavable plastics used in the manufacture of bottles include polypropylene, copolymer, polycarbonate, and polymethylpentene.

The containers given to patients must be easy for them to use. Patients should be instructed in the aseptic collection of specimens and asked to avoid contaminating the outside of containers.

When contamination occurs, wipe the outside of the container with a tissue or cloth soaked in disinfectant before sending the specimen to the laboratory.

- Report any abnormal features, such as cloudiness in a specimen which should appear clear, abnormal coloration, or the presence of pus, blood, mucus, or parasites.

The appearance of urine, pus, vaginal discharge, faeces, effusions, and cerebrospinal fluid should be described routinely.

### Labelling specimens

Each specimen must be clearly labelled with the date and time of collection, and the patient's name, number, ward or health centre.

Slides with one end frosted (area of opaque glass on which to write) should be used for making smears so that a lead pencil can be used to label the slides clearly.

Each specimen must be accompanied by a

correctly completed request form (see previous text).

### Specimens containing dangerous pathogens

Those delivering, receiving, and examining specimens must be informed when a specimen is likely to contain highly infectious organisms. Such a specimen should be labelled HIGH RISK, and whenever possible, carry a warning symbol such as a red dot, star, or triangle which is immediately recognized as meaning that the specimen is dangerous and must be handled with extra care.

Specimens which should be marked as HIGH RISK include:

- Sputum likely to contain *M. tuberculosis*.
- Faecal specimen that may contain *V. cholerae* or *S. Typhi*.
- Fluid from ulcers or pustules that may contain anthrax bacilli or treponemes.
- Specimens from patients with suspected HIV infection, viral hepatitis, viral haemorrhagic fever, or plague.

Immediately after collection, a HIGH RISK specimen should be sealed inside a plastic bag or in a container with a tight-fitting lid. The request form must not be placed in the bag or container with the specimen.

*Note:* Because any specimen may contain infectious pathogens, it is important for laboratory staff to handle all specimens with adequate safety precautions and to wash their hands after handling specimens (see also subunits 3.2–3.4 in Part 1 of the book).

### Preservatives and transport media for microbiological specimens

In general, specimens for microbiological investigations should be delivered to the laboratory without delay and processed as soon as possible. This will help to avoid the overgrowth of commensals.

When a delay in delivery is unavoidable, for example when transporting a specimen from a health centre to a hospital laboratory, a suitable chemical preservative or transport culture medium must be used. This will help to prevent organisms from dying due to enzyme action, change of pH, or lack of essential nutrients. A transport medium is needed to preserve anaerobes.

Amies transport medium is widely used and effective in ensuring the survival of pathogens in specimens collected on swabs, especially delicate organisms such as *Neisseria gonorrhoeae*. Amies medium is a modification of Stuart's transport

medium. Its preparation is described in No. 11 (Appendix I). An example of a preservative is boric acid which may be added to urine.

Cary-Blair medium is used as a transport medium for faeces that may contain *Salmonella*, *Shigella*, *Campylobacter* or *Vibrio* species (see No. 22).

*Note:* Preservatives that contain formaldehyde solution, such as merthiolate iodine formaldehyde (MIF) and formol saline, must *not* be used for microbiological specimens because formaldehyde kills living organisms.

### Transport of microbiological specimens collected in a hospital

As mentioned previously, specimens should reach the laboratory as soon as possible or a suitable preservative or transport medium must be used.

Refrigeration at 4–10°C can help to preserve cells and reduce the multiplication of commensals in unpreserved specimens. Specimens for the isolation of *Haemophilus*, *S. pneumoniae*, or *Neisseria* species, however, must never be refrigerated because cold kills these pathogens.

Smears collected by ward staff or in outpatient clinics for subsequent Gram staining, must be placed in a safe place to dry, protected from dust, ants, cockroaches, and flies. The laboratory should provide wards and outpatient clinics with petri dishes (unsterile) or other containers in which to place and transport slide preparations.

### Dispatch of microbiological specimens collected in health centres or district hospitals without culture facilities

Specimens for dispatch must be packed well and safely. When specimens are to be mailed, the regulations regarding the sending of 'Pathological Specimens' through the post should be obtained from the Postal Service and followed exactly. When dispatching microbiological specimens the following apply:

- Keep a register of all specimens dispatched. Record the name, number, and ward or health centre of the patient, type of specimen, investigation required, date of dispatch, and the method of sending the specimen (e.g. mailing, hand-delivery, etc). When the report is received back from the microbiology laboratory, record the date of receipt in the register.
- Check that the specimen container is free from cracks, and the cap is leak-proof. Seal around the container cap with adhesive tape to prevent loosening and leakage during transit.

- Use sufficient packaging material to protect a specimen, especially when the container is a glass tube or bottle (use a plastic container whenever possible). Place the packaged container in a strong protective tin or box, and seal completely. When the specimen is fluid, use sufficient absorbent material to absorb it should a leakage or breakage occur.
- Mark all specimens that may contain highly infectious organisms, 'HIGH RISK' (see previous text). Do not mail such specimens.
- Dispatch slides in a plastic slide container or use a strong slide carrying box or envelope.
- Label specimens dispatched by mail, 'FRAGILE WITH CARE – PATHOLOGICAL SPECIMEN'.

When a specimen is likely to deteriorate unless kept cool, transport it in an insulated container, such as a polystyrene box or thermos flask containing ice cubes. The specimen must be sealed inside a waterproof bag or tin to prevent the label being washed off when the ice cubes melt. Precautions must also be taken to keep the request form dry.

Note: Details on international transport regulations can be found on p. 66 in Part 1.

### Collection of individual specimens

	<i>Subunit</i>
Sputum . . . . .	7.6
Throat specimens . . . . .	7.7
Skin and ulcer specimens . . . . .	7.8
Skin and nasal smears for leprosy . . . . .	7.18.30
Pus and effusions . . . . .	7.9
Urogenital specimens . . . . .	7.10
Faecal (stool) specimens . . . . .	7.11
Urine . . . . .	7.12
Cerebrospinal fluid (c.s.f.) . . . . .	7.13
Blood for culture . . . . .	7.14
Seminal fluid . . . . .	7.15

Note: Detailed and helpful guidelines on the collection and dispatch of microbiological specimens can be found in the WHO publication *Specimen collection and transport for microbiological investigations*.<sup>2</sup>

### Practice of virology in district laboratories

Viruses, particularly HIV, arboviruses, measles virus, and viruses that cause respiratory and diarrhoeal disease in young children, are major causes of death and illness in tropical and developing countries. At district level most virus diseases are presumptively

diagnosed clinically or remain undiagnosed. It is usually only at central level that facilities exist for the laboratory investigation of virus diseases based on virus isolation, direct demonstration of virus or viral components, and the serological diagnosis of virus infections.

In recent years, however, rapid, simple to perform immunological assays have become available to diagnose virus diseases such as dengue (see subunit 7.18.53), HIV infection (see subunit 7.18.55), and viral hepatitis (see subunit 7.18.54). Where appropriate, affordable, and available, these rapid techniques are being increasingly used in district laboratories and regional blood transfusion centres.

When needing to investigate a serious epidemic caused by Ebola fever virus or other highly infectious virus causing viral haemorrhagic fever, testing must be performed in a virology laboratory or public health laboratory having adequate containment facilities with a specialist public health team (appropriately protected) collecting the samples.

### Practice of mycology in district laboratories

The medically important fungi are listed in subunit 7.2 and the investigation of common fungal infections in district laboratories is described in subunits 7.18.38–7.18.52.

---

### SAFE WORKING PRACTICES

Health and safety in district laboratories, including full coverage of microbial hazards, safe working practices, and the decontamination of infectious material and disposal of laboratory waste are described in Chapter 3 in Part 1 of the book.

The following are some of the important points which apply when working with infectious materials:

- Never mouth-pipette (see p. 63 in Part 1). Use safe measuring and dispensing devices as described in subunit 4.6 in Part 1.
- Do not eat, drink, smoke, store food, or apply cosmetics in the working area of the laboratory.
- Use an aseptic technique when handling specimens and culture (see subunit 7.4).
- Always wash the hands after handling infectious material, when leaving the laboratory and before attending patients. Cover any open wound with a waterproof dressing.
- Wear appropriate protective clothing when working in the laboratory. Ensure it is decontaminated and laundered correctly (see p. 59 in Part 1).



- Wear protective gloves, and when indicated a face mask, for all procedures involving direct contact with infectious materials. When wearing gloves, the hands should be washed with the gloves on, particularly before using the telephone or doing clerical work.
- Minimize the creation of aerosols. The commonest ways infectious aerosols are formed are detailed on pp. 61–62 in Part 1.
- Centrifuge safely to avoid creating aerosols. Know what to do should a breakage occur when centrifuging (see p. 63 in Part 1).
- Avoid practices which could result in needle-stick injury.
- Do not use chipped or cracked glassware and always deal with a breakage immediately and safely (see p. 89 in Part 1).
- Avoid spillages by using racks to hold containers. Work neatly and keep the bench surface free of any unnecessary materials.
- Decontaminate working surfaces at the end of each day's work and following any spillage of infectious fluid. Know what to do when a spillage occurs (see p. 63 in Part 1).
- Report immediately to the laboratory officer in charge, any spillage or other accident involving exposure to infectious material.
- Know how to decontaminate specimens and other infectious materials (see pp. 66–74 in Part 1).
- Use and control an autoclave correctly (see p. 67 and subunit 4.8 in Part 1).
- Dispose of laboratory waste safely (see pp. 66–71 in Part 1).
- Do not overfill discard containers. Use appropriate disinfectants (see pp. 67–70 in Part 1). Use separate containers for 'sharps'.
- Do not allow unauthorized persons to enter the working area of the laboratory.
- Ensure technical and auxiliary staff working in the laboratory receive appropriate immunizations. Those at increased risk of acquiring infections, e.g. immunocompromised persons, should not work in a laboratory handling infectious material.

## REFERENCES

- 1 **Vandepitte J et al.** *Basic laboratory procedures in clinical bacteriology*. WHO, Geneva, 2nd edition, 2003. Obtainable from WHO Publications, Geneva 1211, 27-Switzerland.

- 2 **Engbaeck K et al.** *Specimen collection and transport for microbiological investigation*. WHO Regional Publications, 1995. ISBN 92–9021–196–2. Obtainable from WHO Regional Office for the Eastern Mediterranean, PO Box 7608, Nasr City, Cairo, 11371, Egypt.

## 7.2 Features and classification of microorganisms of medical importance

Most microorganisms are free-living and perform useful activities that benefit animal and plant life. Microorganisms that have the ability to cause disease are called pathogens. They include:

- Bacteria (singular, bacterium)
- Viruses (singular, virus)
- Fungi (singular, fungus)
- Protozoa (singular, protozoon)\*

\*The protozoa of medical importance are described in Chapter 5 in Part 1 of the book.

Infection occurs when a pathogen is able to establish itself in a person. Not all infections, however, result in clinical infection, i.e. a person falling ill. Frequently a person displays no symptoms of disease (asymptomatic). Such an infection is referred to as subclinical.

Virulence is the term used to describe the degree of pathogenicity of an organism. It is mainly dependent on the invasiveness and, or, the ability of the organism to produce toxins (poisonous substances). The infectiousness or communicability of an organism refers to its capacity to spread. Epidemiology is the study of the spread, distribution, prevalence, and control of disease in a community.

### Endemic, epidemic and pandemic disease

**Endemic:** This refers to the constant presence of a disease or agent of disease in a community or region. A sporadic disease is one which breaks out only occasionally.

**Epidemic:** This usually means an acute outbreak of disease in a community or region, in excess of normal expectancy, and derived from a common or propagated source. Many endemic diseases can rapidly become epidemic if environmental or host influences change in a way which favour transmission.

**Pandemic:** This refers to a disease which spreads to several countries and affects a large number of people. HIV disease, influenza and cholera are examples of diseases that have caused or currently are the cause of pandemics.

The control and prevention of outbreaks of infectious disease depend on knowing the reservoirs,

sources, routes of transmission, and effective control measures to use.

### Factors that contribute to the spread of communicable diseases in developing countries

Most microbial diseases are transmitted by:

- ingesting pathogens in contaminated food or water as in cholera, typhoid and paratyphoid fever, bacillary dysentery, hepatitis A, or ingesting pathogens in unpasteurized milk and dairy products as in brucellosis, or *Campylobacter* infections.
- inhaling pathogens in air-borne droplets as in tuberculosis, whooping cough, measles, influenza, pneumonia, meningitis, SARS.
- pathogens being transferred by direct contact from one person to another as in HIV infection, syphilis, gonorrhoea, ringworm infection.
- pathogens entering the blood and tissues through the bite of an arthropod vector as in bubonic plague, rickettsial infections, dengue, rift valley fever.
- pathogens entering wounds, cuts, or burns by way of contaminated hands or unsterile instruments as in infections of the skin such as boils and abscesses and tetanus (via contaminated soil or dust).
- transfer of pathogens in contaminated blood or blood products as in HIV infection, viral hepatitis (HBV, HCV).
- pathogens transmitted from mother to child during pregnancy or childbirth as in HIV infection, congenital syphilis, *Chlamydia* infection, herpes infection, congenital rubella, gonococcal conjunctivitis, cytomegalovirus neonatal infection.

In persons with inadequate immune responses, infections can also be caused by the body's normal microbial flora (organisms that naturally colonize certain areas of the body, see later text).

Important factors which influence the transmission and spread of communicable diseases in tropical and developing countries include:

- Inadequate surveillance, preventive and control measures, and lack of health care facilities in rural areas to detect and treat patients with communicable diseases.
- Socioeconomic factors including increasing urbanization, poverty, unemployment, poorly

constructed houses, overcrowding, malnutrition (particularly protein and vitamin deficiencies), and starvation brought about by drought, crop failure, flooding, war, and mass migration.

- Inadequate and contaminated water supplies, inadequate sewage disposal and unhygienic practices.
- Climatic factors including extreme rainfall and flooding leading to pollution of water supplies and greater numbers of insect vectors. During the dry season, an increase in dust-borne particles can lead to increased transmission, e.g. meningococci.
- Ineffective control of mosquitoes and other insect vectors.
- Geographical factors including the difficulties of vaccination teams and health workers in reaching remote villages.
- Unavailability of drugs and non-compliance by patients.
- Ineffective health education or lack of access to health education.
- Particularly involving young children: disruption to vaccine programmes, malnutrition, and co-existing infection, e.g. malaria.

*Human carriers:* A carrier is a person who is colonized by a pathogen but experiences no disease or only minor symptoms from it. Such a person can excrete the pathogen he or she is carrying over a long period and be a source of infection to others without realizing it. The carrier state is particularly important in the transmission of typhoid fever and also occurs in a proportion (about 10%) of those with hepatitis B infection.

### Body's defence mechanisms

Although the human body continually comes into contact with potentially pathogenic microorganisms, infection and disease are usually prevented or minimized because a healthy body has a range of defence mechanisms to protect it. These consist of:

- Non-specific defences
- Specific immune responses

**Non-specific defences:** Although referred to as natural or innate immunity, these defences are non-immunological. They include the body's natural barriers to infection (skin, mucous membranes, antimicrobial secretions), phagocytosis of pathogens involving polymorphonuclear neutrophils (poly-

morphs) and macrophages, complement, the inflammatory process, and the actions of natural killer (NK) cells.

**Phagocytosis:** Phagocytic cells ingest and kill invading pathogens. Polymorphs circulate in the blood and respond rapidly to infection (form 'pus cells'). Many microorganisms produce chemical substances that attract phagocytes. Macrophages circulate in the blood as monocytes and are present in tissues as fixed or free macrophages. The engulfing of pathogens by phagocytes is facilitated by antibody and, or, complement (opsonization effect). Cytokines released from T lymphocytes (in immune responses) increase the phagocytic action of macrophages.

**Inflammatory response:** (local accumulation of fluid and cells, redness, swelling, pain): This is a protective response to the presence of pathogens or other foreign bodies in tissue. Phagocytes are attracted to the infection site. They engulf and kill the pathogens and a fibrin clot forms to prevent the infection from spreading. Polymorphs predominate in acute pyogenic infections and macrophages and helper T lymphocytes in chronic or granulomatous infections. Cytokines and other substances assist in the inflammatory process.

**Complement:** Consists of a set of proteins which participate in both non-specific and specific immune defences. In non-specific defences, complement can be activated by bacterial peptidoglycan and lipopolysaccharide (alternative pathway). Some Gram negative bacteria are lysed by complement binding to their surface. In the laboratory, complement in serum can be inactivated at 56°C for 30 minutes (antibody is not inactivated at this temperature).

**Natural killer cells:** These are lymphocytes which can kill virus infected cells (and tumour cells) without antigenic stimulation although antibody enhances their activity. They destroy cells by secreting cytotoxins. They have no immunological memory.

**Specific immune responses:** Occur following contact with a 'foreign' antigen, e.g. invading pathogen or its products. Specific immunity involves antibody production by B lymphocytes, cell mediated immune responses by T lymphocytes, and the production of memory cells that enable the body to respond rapidly should infection by the same pathogen recur. Also involved are phagocytic cells, complement, and cytokines (helper factors) which include interleukins, interferons, and tumour necrosis factor.

*Antibody mediated immunity (humoral immunity)*  
Antibodies are produced following the antigenic stimulation of B lymphocytes. The antigen binding receptor on a B lymphocyte is an immunoglobulin (Ig). When first stimulated the B cell proliferates and differentiates into:

- plasma cells which produce specific antibody.

- memory B cells which enable the immune system to react rapidly should the same antigen be encountered in the future (secondary response).

Antibody mediated immunity is the body's main defence against extracellular pyogenic (pus-forming) bacteria such as staphylococci and streptococci, against capsulated bacteria such as pneumococci, *Haemophilus* and *Neisseria* species, and against toxin-producing bacteria such as *Clostridium tetani*, *Vibrio cholerae*, and *Corynebacterium diphtheriae*. Antibody immunity is also important in some virus infections, e.g. hepatitis B virus infection.

**Antibodies:** The first antibodies produced in infection (primary response) are immunoglobulins (Ig) of the IgM class, becoming detectable about 1 week after infection and persisting for about 6 weeks. IgM antibody is a large molecule with up to ten antigen binding sites. It is a good complement fixing antibody and therefore aids lysis of microbial cells. It also acts as an opsonin. It forms the main antibody response in many Gram negative bacterial infections.

About 2 weeks after infection, IgG antibody is produced and is long lasting. IgG antibody is the main antibody formed in a secondary response. It has two antigen binding sites. It also fixes complement, and acts as an opsonin. It passes easily from the blood into tissue spaces and is the only class of Ig that can cross the placenta from mother to fetus.

Other classes of antibody involved in protecting the body are IgA, IgD and IgE. None of these classes of immunoglobulin fix complement or opsonize. IgA is the main immunoglobulin in secretions. It prevents bacteria and viruses attaching to mucous membranes. IgD is found on the surface of many B lymphocytes and in serum but little is known of its functions. IgE is concentrated in the submucosa and binds to mast cells and basophils. It is the main antibody involved in immediate type hypersensitivity anaphylactic reactions. High levels of serum IgE are found in patients with asthma and also in helminth infections such as schistosomiasis, ascariasis, hookworm disease, toxocarosis, and filariasis. IgE causes the release of enzymes from eosinophils.

**Immunization:** Active antibody mediated immunity can also be induced in a person by immunization using vaccine consisting of live bacteria or organisms that have been treated so that they are harmless while remaining antigenic, or dead organisms or their products (e.g. toxins) that have been chemically or physically altered so that they cannot cause harm but can stimulate the body to produce antibodies. Examples of microbial diseases that can be prevented by artificial immunization include diphtheria, whooping cough, mumps, cholera, anthrax, poliomyelitis, rubella, tetanus, tuberculosis, typhoid, and hepatitis B. Immunization against the first three diseases provides life-long immunity. For the other diseases, revaccination may be required every few months or years.

**Passive immunity:** This is when antibodies that have been formed in another human or animal are introduced into the

body, e.g. diphtheria antitoxin to neutralize circulating toxin. Passive immunity occurs naturally when antibodies (IgG) from a mother are transferred across the placenta or maternal antibody is transferred in breast milk after birth. These antibodies protect an infant during the first few months of its life until it begins to make its own protective antibodies.

### Cell mediated immunity

The cells involved are macrophages, helper T lymphocytes and cytotoxic T lymphocytes. Cell-mediated immunity is mainly directed at virus infected cells, intracellular fungi, and intracellular bacteria such as *Mycobacterium tuberculosis*, *Mycobacterium leprae*, and *Brucella* species.

#### Helper T cells (CD4 positive)

CD4<sup>+</sup> helper T cells carry CD4 glycoprotein markers on their surface. They are important cells in cellular immunity. They release cytokines, help to activate B lymphocytes, and modulate cellular immune responses. Helper T cells recognize antigen bound to MHC (major histocompatibility complex) class II protein.

#### Cytotoxic T cells (CD8 positive)

CD8<sup>+</sup> cytotoxic T cells carry CD8 glycoprotein markers on their surface. They recognize antigen bound to MHC I class protein, mainly on virus-infected cells. They produce cytotoxins which destroy cells infected with viruses and other intracellular organisms. Cytotoxins are also important in eliminating tumour cells.

Effective and correctly regulated immune responses are dependent on there being the correct ratio of helper CD4<sup>+</sup> T cells to cytotoxic CD8<sup>+</sup> T cells (normally CD4: CD8 cells > 1.5). When there are insufficient helper T cells, e.g. in HIV disease in which CD4<sup>+</sup> T cells are destroyed, immune responses become impaired. This leads to increased susceptibility to infection with pathogens such as *Mycobacterium tuberculosis*, and the development of opportunistic infections and certain tumours (see also subunit 7.18.55).

### How microorganisms overcome the body's defences and cause disease

The following are some of the ways developed by pathogens to overcome the body's defence mechanisms, become established in tissues, multiply, and cause disease:

- Adherence fimbriae (pili)
- Production of enzymes that facilitate the spread of pathogens
- Mechanisms that interfere with phagocytosis
- Production of *beta*-lactamases
- Mechanisms that destroy or neutralize antibodies
- Production of exotoxin

- Release of endotoxin

**Adherence fimbriae (pili):** These are small hairs that enable some pathogens to attach and adhere easily to cell surfaces, particularly mucous membranes. Bacteria possessing pili include *Neisseria gonorrhoeae* and some strains of *Escherichia coli*, *Salmonella* and *Shigella* species.

**Enzymes that help pathogens to spread:** For example, hyaluronidase produced by *Clostridium perfringens* and some streptococci and staphylococci, helps organisms to spread through the body by breaking down the hyaluronic acid of connective tissue.

**Mechanisms that interfere with phagocytosis:** Bacteria such as *Streptococcus pneumoniae*, *Klebsiella pneumoniae*, *Haemophilus influenzae*, and *Neisseria meningitidis* secrete a capsule around their cell wall which helps to prevent opsonization and phagocytosis. The M protein in the cell wall of *Streptococcus pyogenes* is anti-phagocytic and the haemolysins and leucocidins of streptococci and staphylococci interfere with the functioning of phagocytes and destroy polymorphs and macrophages.

**Production of *beta*-lactamases:** These penicillin-destroying enzymes are produced by many bacteria including some strains of *Staphylococcus aureus* and *Neisseria gonorrhoeae*.

**Mechanisms that destroy or neutralize antibodies:** For example, the destructive IgA protease of *Pseudomonas aeruginosa*. Other pathogens produce soluble antigen which neutralizes antibody before it is able to bind to the surface of bacteria.

**Production of exotoxin:** Several Gram positive and a few Gram negative bacteria secrete powerful poisons called exotoxins that are capable of destroying or injuring host cells. They tend to be specific in their action, e.g. the exotoxin of *Clostridium tetani* is a neurotoxin. Other important exotoxin-producing pathogens include *Clostridium botulinum*, *Clostridium perfringens*, *Corynebacterium diphtheriae*, enterotoxigenic *Escherichia coli* (ETEC), *Shigella dysenteriae*, and *Vibrio cholerae*. Toxin produced by enteric pathogens is known as enterotoxin.

Exotoxins are highly antigenic. By special chemical preparation, exotoxins can be made into non-toxic toxoids which can be used to immunize and protect individuals against specific diseases.

**Release of endotoxin:** The cell walls of Gram negative organisms contain endotoxin (O antigen). Unlike exotoxin, endotoxin is not usually secreted by an organism but is released only when the organism is destroyed. When endotoxin is released into the blood circulation, the resulting toxemia may cause rigor, chills, and shock. Endotoxin from some pathogens may also have clotting properties and lead to disseminated intravascular coagulation (DIC). Endotoxin release may also lead to a marked leucocytosis. In contrast to exotoxin, endotoxin is only weakly antigenic. It is also more heat stable than exotoxin.

Other factors which determine whether a pathogen will cause disease include:

- Transmission route
- Number of bacteria that invade
- State of health of the person infected

For a pathogen to cause disease it must enter the body by a route which will enable it to reach a site where it can establish itself and multiply, e.g. the *Clostridium* organism which causes gas gangrene must reach deep tissues to find the anaerobic conditions necessary for its growth. Other organisms such as *Staphylococcus aureus* can cause several different diseases depending on whether the organism is ingested (e.g. food-poisoning), infects the skin (e.g. boils), or reaches the lung (e.g. pneumonia).

Certain organisms may require a vector for their development and transmission, e.g. rickettsiae develop in an arthropod such as a tick, mite, flea or louse, and are transmitted to man when the arthropod bites and the organisms are injected into the blood.

For some bacteria, the entry of large numbers of organisms may be necessary before a healthy person's defence mechanisms are overcome, whereas only a few organisms may be required to produce disease in a person already in poor health, a malnourished person (especially a child) or a person with immunosuppression caused for example by HIV disease. Particularly virulent bacteria, however, need only be present in very small numbers to cause disease, e.g. *Shigella dysenteriae*.

## LABORATORY INVESTIGATION OF MICROBIAL INFECTIONS

The laboratory investigation of microbial diseases involves:

- Examining specimens to detect, isolate, and identify pathogens or their products using:
  - Microscopy
  - Culture techniques
  - Biochemical methods
  - Immunological (antigen) tests
- Testing serum for antibodies produced in response to infection, i.e. serological response.

## Examination of specimens for microorganisms MICROSCOPY

To assist in the diagnosis of microbial infections, microorganisms can be examined microscopically for their motility, morphology, and staining reactions.

### Examples

- Motile *Vibrio cholerae* in a rice water faecal specimen from a person with cholera.
- *Treponema pallidum* in chancre fluid (using dark-field microscopy), establishing a diagnosis of primary syphilis.
- Fungal hyphae and arthrospores in a sodium hydroxide preparation of skin from a person with ringworm.
- Gram negative reaction and characteristic morphology of *Neisseriae gonorrhoeae* (intracellular diplococci) in a urethral discharge from a man with gonorrhoea.
- Gram positive reaction and morphology of pneumococci in cerebrospinal fluid from a patient with pneumococcal meningitis.
- Gram positive reaction and morphology of yeast cells in a vaginal discharge from a woman with vaginal candidiasis.
- Acid fast reaction of *Mycobacterium tuberculosis* in Ziehl-Neelsen stained sputum from a person with pulmonary tuberculosis.

*Note:* Microscopical techniques are described in subunit 7.3 and in subsequent subunits covering the examination of different specimens.

## CULTURE TECHNIQUES

The culture of pathogens enables colonies of pure growth to be isolated for identification and, when required, antimicrobial susceptibility testing.

*Note:* The cultural requirements of pathogens, preparation, inoculation and quality control of culture media are described in subunit 7.4, and the use and reporting of cultures in the subunits describing the examination of different specimens. Antimicrobial susceptibility testing is described in subunit 7.16.

## BIOCHEMICAL METHODS

Following culture, biochemical tests are often required to identify pathogens including the use of substrates and sugars to identify pathogens by their enzymatic and fermentation reactions.

### Examples

- Catalase test to differentiate staphylococci which produce the enzyme catalase from streptococci which are non-catalase producing.
- Oxidase test to help identify *Vibrio*, *Neisseria*, *Pasteurella* and *Pseudomonas* species, all of which produce oxidase enzymes.
- Coagulase test to help identify *Staphylococcus aureus* which produces the enzyme coagulase (coagulates plasma).
- Fermentation tests to differentiate enterobacteria, e.g. use of glucose and lactose in Kligler iron agar medium to assist in the identification of *Shigella* and *Salmonella* organisms.
- Indole test to detect those organisms that are able to break down tryptophan with the release of indole. It is mainly used to differentiate *Escherichia coli* from other enterobacteria.

- Urease test to assist in the identification of organisms such as *Proteus* species which produce the enzyme urease.

*Note:* Biochemical test methods are described in subunit 7.5.

While kits for the identification of bacteria and fungi (visual, chart, and computer-based) are available, e.g. API system, they are expensive and not always needed. In this publication, conventional biochemical testing methods are described, using reagents that can be prepared in the laboratory or are easily and economically available as ready-made reagents or as strip, disc, or tablet reagents.

### IMMUNOLOGICAL (ANTIGEN) TESTS

Antigen tests often enable an early diagnosis or presumptive diagnosis of an infectious disease to be made. They involve the use of specific antibody (antisera or labelled antibody):

- To identify a pathogen that has been isolated by culture, e.g. identification of *Salmonella* serovars, *Shigella* species, and *Vibrio cholerae* by direct slide agglutination.
- To identify pathogens in specimens using direct immunofluorescence, e.g. identification of respiratory viruses, rabies virus, cytomegalovirus, *Pneumocystis jiroveci*, and *Chlamydia*. Fluorescence techniques are more difficult to perform in district laboratories.
- To identify antigens of microbial origin that can be found in serum or plasma, cerebrospinal fluid, urine, specimen extracts and washings, or fluid cultures. Highly specific monoclonal antibody reagents are often used. Techniques to identify soluble microbial antigens include agglutination techniques (direct, latex, coagglutination), enzyme immunoassays (EIA), or more recently developed immunochromatographic (IC) tests and dipstick dot immunoassays. Examples are listed in chart 7.2. Because many of these antigen tests are rapid, simple to perform, and have good stability, they are becoming increasingly used at district level. Adequate controls must be used.

### PRINCIPLES OF ANTIGEN TESTS

#### Direct slide agglutination

This is used to identify bacteria following culture on a carbohydrate-free medium. A bacterial colony of pure growth is emulsified in physiological saline on a slide and antiserum containing specific antibody is added. The antibody binds to the bacterial antigen, resulting in the agglutination of the bacterial cells.

Antiserum + Bacteria → Bacteria AGGLUTINATED

#### Latex agglutination

Latex particles are coated with specific antibody. The specimen containing microbial antigen is mixed with the latex reagent, resulting in agglutination of the latex particles.

Antibody latex + Antigen in → Latex particles  
reagent specimen AGGLUTINATED

#### Coagglutination (COAG)

Specific antibody is bound to the surface protein A of staphylococci (Cowan type 1 strain of *Staphylococcus aureus*). Soluble microbial antigen in the specimen is mixed with the COAG reagent, resulting in the agglutination of the staphylococcal cells.

Antibody COAG + Antigen in → Staphylococcal cells  
reagent specimen AGGLUTINATED

#### Direct immunofluorescence

Specific antibody is conjugated (joined) to a fluorochrome such as fluorescein isothiocyanate and applied to the specimen containing the pathogen on a slide. The fluorochrome antibody conjugate binds to the pathogen (antigen). When examined by fluorescence microscopy the pathogen is seen to fluoresce (e.g. yellow-green or orange) against a dark background. Because of the specialized equipment and expertise required to prepare and read fluorescence preparations, immunofluorescence techniques are not often performed in district laboratories.

Fluorochrome + Antigen → Pathogen  
antibody reagent (pathogen) FLUORESCES

#### Enzyme immunoassays (EIA)\* to detect antigen

\*Enzyme assays are also referred to an enzyme linked immunosorbent assays (ELISA).

Antibody against the antigen to be detected is fixed to the well of a microtitration plate or membrane of an individual test device such as a plastic block. Soluble microbial antigen in the specimen binds to the antibody. After washing, antibody conjugated to an enzyme (e.g. horseradish peroxidase) is added. This binds to the captured antigen. After another wash, a chromogenic (colour-producing) substrate such as hydrogen peroxide joined to an indicator is added. The enzyme hydrolyzes the substrate, producing a colour reaction. The colour can be read visually (membrane EIA) or spectrophotometrically (microtitration plate EIA).

- 1 Fixed antibody + Antigen in → Antigen binds  
specimen to antibody
- 2 Enzyme conjugated → Binds to antigen-antibody  
antibody added complex
- 3 Chromogenic substrate added → COLOUR produced

*Note:* Most flow-through membrane EIAs are rapid, usually have built-in controls, require no additional equipment, and enable specimens to be tested individually.

#### Immunochromatographic (IC) techniques to detect antigen

Most IC tests are produced in strip or cassette form with the immunological reagents fixed on the strip or cassette membrane. When using an IC strip, the lower end is immersed in the specimen or if using an IC cassette, the specimen is applied to an absorbent pad. Antigen in the specimen first meets specific antibody conjugated to colloidal gold (pink-mauve) particles and the antigen binds to the antibody. The antigen-antibody colloidal gold complex migrates up the strip (or along the membrane) where it becomes bound (captured)

by a line of specific antibody, producing a pink line in the test result area. A further pink line, i.e. inbuilt positive control, is produced above the test line, showing that the test has performed satisfactorily.

- 1 Antigen in the specimen + Antibody colloidal gold conjugate → Antigen binds to antibody
- 2 Antigen-antibody complex colloidal gold + Meets Antibody line on strip → Complex captured PINK LINE produced

#### Dipstick comb immunoassays to detect antigen

These assays involve dipping a plastic comb in the specimen and reagent solutions. Each comb is designed for testing up to 6 specimens and controls although the comb can be cut when there are fewer specimens. When used for antigen detection, specific antibody is fixed to the ends of the comb teeth. The comb is dipped in the specimen and antigen in the specimen is captured by the antibody. After washing, the comb is dipped in a colloidal gold antibody conjugate. This binds to the antibody-antigen complex. After washing, a pink dot is produced, indicating a positive test. Although easy to perform, dipstick assays are not as rapid as most IC strip or cassette immunoassays.

- 1 Antibody on teeth of comb + Antigen in specimen → Antigen binds to antibody
- 2 Colloidal gold conjugate applied → Binds to antigen-antibody complex PINK DOT produced

*Immunodiagnosics developed by PATH:* Some of the most affordable, available, stable, and rapid antigen (and antibody) tests are the IC tests and comb dipstick tests developed by PATH (Program for Appropriate Technology for Health). They are produced and distributed by several manufacturers under licence from PATH. Some of these manufacturers are listed in chart 7.2. PATH is continuing to develop new products to diagnose major bacterial, viral, and parasitological diseases and details of these can be obtained from PATH (see Appendix 11).

#### Testing serum for antibodies (serological tests)

In district laboratories, serological testing in which antigen is used to detect and measure antibody in a person's serum is used mainly:

- To help diagnose a microbial disease when the pathogen or microbial antigen is not present in routine specimens or if present is not easily isolated and identified by other available techniques, e.g. dengue, brucellosis, rickettsial infections, syphilis, leptospirosis.
- To test individuals and screen donor blood for antibody to HIV-1 and HIV-2.
- To measure antibody levels to determine the

prevalence of infectious disease in a community and immune status of individuals.

- To screen for rises in anti-streptolysin O, e.g. in the investigation of rheumatic fever, acute glomerulonephritis, and other complications of Group A streptococcal infection.
- To screen pregnant women for infections such as syphilis and HIV infection.

#### *Demonstrating active infection in clinical diagnosis*

For many common infections, antibodies (IgG) against the pathogens involved will often be present in a person's serum from a previous infection or following natural or acquired immunization. Levels of such antibodies are usually low.

To diagnose active infection it is necessary to detect a particularly high level of antibody or preferably, when possible, to demonstrate a four-fold increase in IgG antibody in paired sera (acute i.e. soon after the onset of symptoms, and convalescent samples), taken 10–14 days apart. Alternatively, active infection can be shown by demonstrating IgM antibodies in the serum which are produced early in an infection and do not persist for more than a few weeks.

When previous exposure is unlikely, e.g. rare infections, the finding of antibody in serum collected during the infection is significant and testing a second serum is often not required. In diagnosing neonatal infections, it is necessary to test for IgM antibody because this will show that the antibody has been produced by the infant and is not maternal IgG antibody (IgM antibody does not cross the placenta).

*Antibody titre:* The level of antibody in a serum can be determined by testing dilutions of the serum using a double dilution technique, e.g. 1 in 2, 1 in 4, 1 in 8, 1 in 16 etc. The last dilution to show antibody activity gives the titre (strength) of antibody, e.g. if the end-point dilution is 1 in 8, the antibody titre is 8. A four-fold rise in titre to e.g. 32 in a convalescent serum, would be an indication of active infection. Sometimes, however, the titre is slow to rise or may show no rise depending on when the sera are collected.

*Prozone effect:* When testing a serum (agglutination technique) that has a high antibody level, e.g. from a patient with acute brucellosis, it is possible for only the higher dilutions, e.g. over 1 in 40 or 1 in 80 to show agglutination. This is referred to as a prozone reaction and is probably caused by excess protein coating the antigen particles.

#### *Collection of blood for antibody testing*

Sufficient serum for most antibody tests can be

**Chart 7.2 Examples of antigen and antibody tests****Antigen Tests**

<b>PATHOGEN/MICROBIAL ANTIGEN DETECTED</b>	<b>TEST</b>	<b>MANUFACTURER</b>
● <i>Salmonella</i> , <i>Shigella</i> , <i>Vibrio cholerae</i> identification from culture	Direct agglutination	1, 2, 4, 9, 19, 22, 25, 26, 31
● <i>Vibrio cholerae</i> from faeces	IC Dipstick	19
● <i>Neisseria meningitidis</i> , <i>Streptococcus pneumoniae</i> , <i>Haemophilus influenzae</i> , <i>Escherichia coli</i> antigens in c.s.f.	Latex COAG	4, 8, 25 9
● <i>Cryptococcus neoformans</i> in c.s.f. and serum	Latex	5, 25
● Hepatitis B surface antigen (HbsAg) in serum or plasma	Latex IC strip IC cassette	1, 10, 24 15, 22, 24, 29, 32 6, 12, 21*, 22, 23, 32
● <i>Beta</i> -haemolytic streptococci cell wall antigens (Lancefield grouping)	Latex COAG EIA membrane	1, 2, 19, 10, 25, 31 9 4
● <i>Streptococcus pyogenes</i> from throat swab	IC cassette COAG	15, 16, 28, 29, 30 9
● <i>Neisseria gonorrhoeae</i> identification from culture	COAG IC membrane	4, 9 14
● <i>Staphylococcus aureus</i> identification from culture	Latex	1, 2, 8, 9, 10, 25, 31
● Pregnancy direct test to detect HCG in urine	Latex IC	1, 10, 24 6, 10, 13, 15, 20, 22, 29, 32
● <i>Chlamydia</i> from urogenital specimens	IC	11, 20, 29, 30, 32

*Note:* Other antigen tests are also available from several of the manufacturers listed in this chart. This type of technology is developing rapidly but the cost of most antigen tests is high.

**Antibody Tests**

<b>DISEASE BEING INVESTIGATED</b>	<b>TEST</b>	<b>MANUFACTURER</b>
● Dengue	IC cassette IC Strip	14, 17, 22 32
● <i>S. Typhi</i> IgM antibodies	IC membrane IC Dipstick	14 32, 33
● Brucellosis	Direct agglutination	1, 4, 10, 22, 24, 25
● Syphilis: – Cardiolipin antibody (e.g. RPR) – Specific treponemal antibody	Flocculation IC strip TPHA TPPA	1, 4, 7, 10, 24, 26, 28 13*, 22, 32 1, 2, 7, 10, 24, 31 3



● Leptospirosis	IC membrane	14
	Agglutination	27
● Rickettsial infections	Agglutination	1, 10, 22
	IC cassette	32
● HIV infection	IC cassette	21, 32
	Agglutination	3, 21
	Comb dipstick	6*, 18*, 19, 22*, 26*
	Flow through membrane	7, 12, 15, 21, 22, 24
● Detection of anti-streptolysin O (ASO)	Latex	1, 3, 10, 24, 26
● Detection of rheumatoid factor (RA)	Latex	1, 10, 24

\*PATH collaboration in development of test (see previous text).

**Manufacturers** (addresses in Appendix 11): 1 HD Supplies, 2 Oxoid, 3 Fujirebio, 4 BP Diagnostics, 5 Immuno-Mycologies 6 Laboratorium Hepatika, 7 Abbott Diagnostika, 8 bioMérieux, 9 Boule Diagnostics, 10 Plasmatec, 11 Diagnostics for the Real World, 12 Mitra J, 13 Quest Diagnostics, 14 Zephyr Biomedicals (Tulip Group), 15 Acorn Laboratories, 16 Biomerica, 17 PanBio, 18 Concept Foundation, 19 Span Diagnostics, 20 Teco Diagnostics, 21 Trinity Biotech, 22 Pacific Biotech 23 Orchid Biomedical, 24 Tulip Group, 25 Bio-Rad Laboratories, 26 Wiener Laboratories, 27 KIT Biomedical, 28 Binax, 29 Savyon Diagnostics, 30 Unipath, 31 Mast Group, 32 Standard Diagnostics Inc, 33 Malaysian Bio-Diagnostic Research Sdn.

obtained from 3–5 ml of venous blood. For some micro-techniques, a smaller volume of blood may be adequate and it may be possible to use capillary blood collected on to filter paper (the testing laboratory should always provide written instructions to those collecting blood).

Collect the blood in a dry leak-proof glass tube or bottle (avoid plastic because blood does not clot well in a plastic container). A sterile container should be used when the blood is sent to a referral laboratory. Store the blood at 4–6 °C. If unable to test the specimen within 48 hours, separate the serum from the cells. To do this, allow the blood to clot and after the clot has retracted and sedimented (or centrifuge the blood), use a plastic or glass Pasteur pipette to transfer the serum (cell-free) to a leak-proof plastic or glass container. Label with the patient's name, identity number, and date of collection. Haemolyzed and lipaemic serum samples are unsuitable for antibody testing. Precautions to avoid haemolysis are described in subunit 8.3.

### **Serological techniques used in district laboratories**

Serological techniques most frequently used in district laboratories are those that can be performed simply and economically, use stable reagents, do not require specialist equipment and enable specimens to be tested individually or in small numbers. Such techniques include agglutination tests, flocculation tests, enzyme immunoassays (membrane based EIA), immunochromatographic strip, cassette and card tests, and dipstick comb immunoassays. Examples are listed in Chart 7.2.

### PRINCIPLES OF ANTIBODY TESTS

#### **Agglutination techniques**

To detect antibody, the following agglutination techniques are used:

- Direct slide and tube agglutination tests in which a bacterial antigen reagent is used to agglutinate antibody in serum.

Bacterial suspension + Antibody in patient's serum → AGGLUTINATION

- Latex agglutination tests in which latex particles are coated with antigen to detect antibody in the patient's serum

Latex antigen reagent + Antibody in patient's serum → Latex particles AGGLUTINATED

- Indirect (passive) haemagglutination (IHA) test in which antigen is coated on treated red cells (often bird cells because these are nucleated and sediment rapidly). Antigen-coated red cells are referred to as sensitized cells. Most IHA tests are performed in microtitration plates. The sensitized cells are added to dilutions of the patient's serum. Antibody in the serum agglutinates the cells and they settle forming an even covering in the bottom of the well. When there is no antibody, the cells are not agglutinated and they form a red button in the bottom of the well.

Sensitized red cells + Antibody in patient's serum → Red cells AGGLUTINATED  
Smooth covering in well

#### **Flocculation tests**

A soluble antigen reagent is used to react with antibodies in the patient's serum to form floccules (clumps of precipitate).

Antigen reagent + Antibody in patient's serum → FLOCCULATION

#### **Enzyme immunoassays (EIA) to detect antibody**

In EIA (ELISA) techniques to detect antibody, antigen is

bound to the cell well of a microtitration plate or filter membrane (EIA membrane test) and the patient's serum added. Antibody binds to the antigen. After washing, anti-human immunoglobulin (AHG) conjugated with an enzyme is added which binds to the antibody-antigen complex. After a further wash, a chromogenic enzyme substrate is added, producing a colour reaction which is read spectrophotometrically (microtitration plate EIA) or visually (membrane EIA). Controls are run with the tests. Microtitration plate EIAs require specialist equipment and training and to be performed economically, specimens need to be tested in batches.

- 1 Antigen in well + Antibody in → Antibody  
or on membrane patient's serum captured
- 2 Enzyme conjugated → Binds to antibody antigen  
to AHG added complex
- 3 Chromogenic substrate added → COLOUR produced

*Note:* Most flow-through membrane immunoassays to detect antibody are not enzyme based. Like IC assays (explained in the following text), most membrane immunoassays use a colloidal gold conjugate to visualize the antigen-antibody reaction.

#### **Immunochromatographic (IC) strips, cassettes and cards to detect antibody**

Rapid easy to use IC strips, cassettes and cards to detect antibody are becoming increasingly available for the diagnosis of microbial infections. They are similar in format to those described previously for antigen detection. To detect antibody, the lower end of an IC strip is immersed in the patient's serum or the sample is added to a samples well. Antibody in the specimen reacts with specific antigen bound to colloidal gold particles and the antibody binds to the antigen. The antibody-antigen colloidal gold complex migrates along the membrane where it becomes captured by a line of specific antigen, producing a pink line in the test area. A further pink line, i.e. positive control is produced above this, showing that the test has performed satisfactorily.

- 1 Antibody in + Antigen bound → Antibody binds  
serum to colloidal gold to antigen
- 2 Antibody-antigen .. Meets .. Antigen line → Complex  
colloidal gold captured  
complex PINK LINE  
produced

#### **Dipstick comb immunoassays to detect antibody**

The format of dipstick combs to detect antibody is similar to that previously described for antigen detection except specific antigen not antibody is fixed to the end of each tooth. The antigen captures the antibody in the patient's serum. After washing the comb is dipped in a protein A colloidal gold conjugate which binds to the antibody-antigen complex, producing a pink dot.

- 1 Antigen on teeth + Antibody in → Antibody binds  
of comb serum to antigen
- 2 Protein A colloidal gold → Binds to antibody-antigen  
applied complex  
PINK DOT produced

#### **Sensitivity and specificity of immunoassays**

When comparing the performances of different immunoassays and selecting which test to use, it is important to know how sensitive and specific a particular assay is so that the most appropriate test is

selected. The sensitivity of an assay refers to its ability to identify all those that are infected. The specificity of an assay is its ability to identify correctly all those not infected. For example, a highly sensitive test should be used to screen donor blood for antibodies to HIV to ensure a positive test result is obtained from all sera that contain anti-HIV1 and anti-HIV2 antibodies. Definitive tests should be specific to minimize false positive test results. Most manufacturers supply details of the sensitivity and specificity of their assays and also information on a test's limitations and possible cross-reactions.

Even when a test is highly sensitive and specific and correctly performed with appropriate controls, there is still a possibility of false positive results when the prevalence of a disease is low. Confirmatory testing becomes important in these situations. The higher the predictive value of a test, the higher the possibility in any population that a positive test means disease.

*Note:* Further information on predictive values and how to calculate the specificity and sensitivity of tests (expressed as percentages) can be found in subunit 2.2 in Part 1 of the book.

#### **Nucleic acid tests to diagnose microbial infections**

Recent advances in nucleic acid probe technologies and gene amplification techniques (e.g. polymerase chain reaction, PCR), have resulted in the development of a new generation of rapid, highly sensitive and specific tests to identify pathogens in clinical specimens and cultures, often at an earlier stage than by other tests. As yet only a few manufacturers are producing these new technologies and because of their very high cost, more demanding technique, and specialist training required, only a few research and specialist laboratories are using them.

---

#### **FEATURES AND CLASSIFICATION OF BACTERIA**

Bacteria form a large group of unicellular parasitic, saprophytic and free-living microorganisms, varying in size from 0.1–10 µm long. They have a simple cell structure, contain both deoxyribonucleic acid (DNA) and ribonucleic acid (RNA), and multiply by binary fission. They are classified by their morphology, staining reactions, cultural characteristics, biochemical reactions, antigenic structure, and increasingly by their genetic composition using specialized molecular biology techniques.

#### **Bacterial structure**

Bacteria have a simple cell structure consisting of:

- Cytoplasm containing the bacterial chromosome (genome), ribosomes, stored energy inclusions,

and often plasmids (extra-chromosomal fragments).

- Cytoplasmic membrane and mesosomes.
- Cell wall (except bacteria with deficient cell walls).
- External structures, including (depending on species) a capsule, fimbriae (pili), and flagella.

Spores are produced by *Bacillus* and *Clostridium* species of bacteria.

**Genome:** Bacteria are prokaryotes, i.e. their genetic material is not organized into chromosomes inside a nuclear membrane but consists of a single usually circular chromosome of double-stranded DNA which lies coiled in the cytoplasm, attached to a septal mesosome.

**Plasmids:** These are small, self-replicating, double-stranded circular DNA molecules which enable genetic material to be exchanged within and between bacterial species through specialized sex pili (see later text). Depending on the genes contained in the plasmid, one bacterium may confer on another, properties such as antimicrobial resistance or toxin production. Different plasmids can be found in the same bacterium.

**Ribosomes:** These are sites of protein production distributed in the cytoplasm. They are composed of RNA and proteins.

**Inclusion granules:** Composed of volutin, lipid and polysaccharide. These cytoplasmic inclusions are sources of stored energy.

**Cytoplasmic membrane and mesosomes:** The cytoplasmic membrane acts as a semi-permeable membrane controlling the movement of water, nutrients, and excretory substances in and out of the cell. It also secretes extracellular enzymes and toxins. Mesosomes appear as convoluted indentations in the cytoplasmic membrane (see Fig 7.1). They are sites of respiratory enzyme activity and assist with cell reproduction.

**Cell wall:** This provides the bacterial cell with rigidity and protects against osmotic damage. The cell wall is strengthened by a mucopolysaccharide polymer called peptidoglycan. Based on differences in the composition of bacterial cell walls, most bacteria when stained by the Gram staining technique (described in subunit 7.3) can be divided into those that are Gram positive, i.e. retain the stain crystal violet, and those that are Gram negative, i.e. are decolorized and take up the red counterstain.

The cell wall of Gram negative bacteria contains a smaller amount of peptidoglycan and there is an outer membrane which contains toxic lipopolysaccharides (endotoxins).

**Note:** Spirochaetes (*Treponema*, *Borrelia*, *Leptospira* species) have a flexible thin cell wall.

**External structures (flagella, fimbriae, capsule):** Motile bacteria possess one or more thread-like flagella. Some bacteria such as *Salmonella* species are identified by the specific antibodies formed against flagellar proteins.

Many Gram negative bacteria and some Gram positive bacteria have hair-like structures called fimbriae (pili). They enable organisms to adhere to host cells and to one another. Specialized sex fimbriae enable genetic material to be transferred from one bacterium to another, a process called conjugation.

Many bacteria secrete around themselves a polysaccharide substance (or sometimes protein) which may become suffi-

ciently thick to form a definite capsule. Possessing a capsule usually increases the virulence of an organism. Special techniques are required to demonstrate bacterial capsules, e.g. India ink preparation or dark-field microscopy. Capsular polysaccharide antigens (K antigens) enable pneumococci to be identified serologically.

**Spores:** When conditions for vegetative growth are not favourable, especially when carbon and nitrogen become unavailable, bacteria of the genera *Bacillus* and *Clostridium* are able to survive by forming resistant endospores. Spore formation involves a change in enzyme activity and morphology. The spore may be positioned at the end (terminal) of the bacterium or centrally (median). It may be round, oval, or elongate. Endospores being dense and thick-walled, are able to withstand dehydration, heat, cold, and the action of disinfectants. A spore is unable to multiply but when conditions for vegetative growth return, it is able to produce a bacterial cell which is capable of reproducing.

## Morphology of bacteria

Morphologically bacteria can resemble:

- Cocci (Singular: coccus)
- Bacilli (rods) (Singular: rod, bacillus)
- Vibrios (Singular: vibrio)
- Spirilla (Singular: spirillum)
- Spirochaetes (Singular: spirochaete)

**Note:** Several species of bacteria are able to change their form, especially after being grown on artificial media. Organisms which show variation in form are described as pleomorphic.

**Cocci:** These are round or oval bacteria measuring about 0.5–1.0  $\mu\text{m}$  in diameter. When multiplying, cocci may form pairs, chains, or irregular groups:

- cocci in pairs are called diplococci, e.g. meningococci and gonococci.
- cocci in chains are called streptococci, e.g. *Streptococcus pyogenes*.
- cocci in irregular groups are called staphylococci, e.g. *Staphylococcus aureus*.

**Gram reaction:** Staphylococci and streptococci are Gram positive, whereas diplococci can be Gram positive or Gram negative.

**Rods (bacilli):** These are stick-like bacteria with rounded, tapered (fusiform), square, or swollen ends. They measure 1–10  $\mu\text{m}$  in length by 0.3–1.0  $\mu\text{m}$  in width. The short rods with rounded ends are often called coccobacilli. When multiplying, bacterial rods do not usually remain attached to one another, but separate. Occasionally, however, they may:

- form chains, e.g. *Streptobacillus* species.
- form branching chains, e.g. lactobacilli.
- mass together, e.g. *Mycobacterium leprae*.

– remain attached at various angles resembling Chinese letters, e.g. *Corynebacterium diphtheriae*.

As explained previously, the rods of the genera *Bacillus* and *Clostridium* are able to form resistant spores when conditions for vegetative growth are unfavourable. Many rods are motile having a single

flagellum, or several flagella, at one or both ends or surrounding the entire organism.

*Gram reaction:* Many rods are Gram negative such as the large group of enterobacteria. Gram positive rods include *Clostridium* species, *Corynebacterium* species, *Bacillus anthracis*, and *Listeria monocytogenes*.

*Note:* Some coccobacilli, such as *Yersinia* species, show bipolar staining when stained with methylene blue or Giemsa.

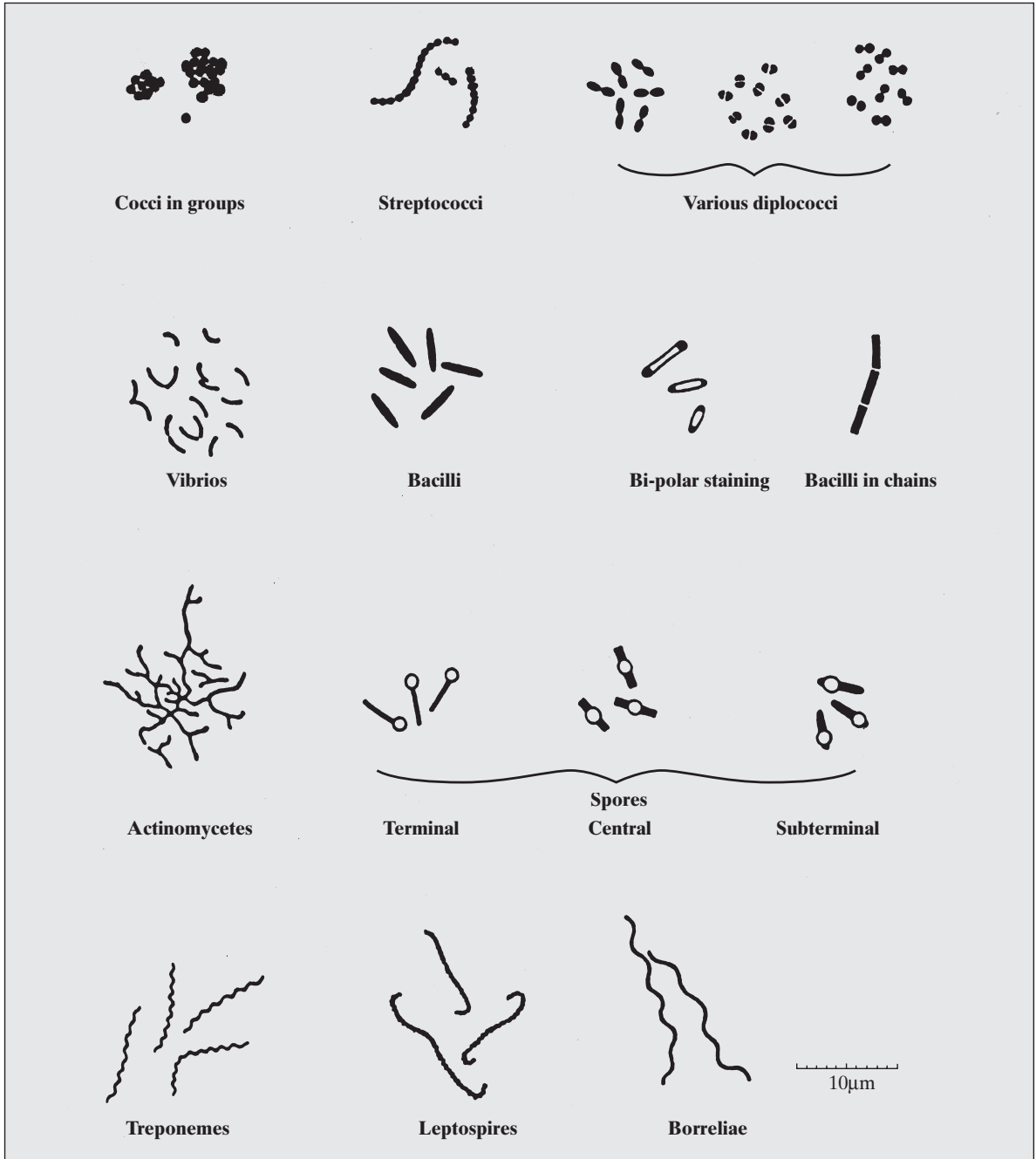

Fig 7.1 Morphological features of bacteria.

**Vibrios:** These are small slightly curved rods measuring 3–4  $\mu\text{m}$  in length by 0.5  $\mu\text{m}$  in width. Most vibrios are motile with a single flagellum at one end. They show a rapid darting motility, e.g. *Vibrio cholerae*.

*Gram reaction:* Vibrios are Gram negative.

**Spirilla:** These are small, regularly coiled, rigid organisms measuring about 3–4  $\mu\text{m}$  in length. Each coil measures about 1  $\mu\text{m}$ . Spirilla are motile with groups of flagella at both ends. An example of a spirillum is *Spirillum minus*.

*Gram reaction:* Spirilla are Gram negative.

**Spirochaetes:** These are flexible, coiled, motile organisms. They progress by rapid body movements. Most are not easily stained by the Gram method. Spirochaetes are divided into three main groups:

- treponemes, which are thin delicate spirochaetes with regular tight coils, measuring from 6–15  $\mu\text{m}$  by 0.2  $\mu\text{m}$  in width. Examples include *Treponema pallidum* and *Treponema pertenue*.
- borreliae, which are large spirochaetes with irregular open coils, measuring 10–20  $\mu\text{m}$  in length by about 0.5  $\mu\text{m}$  in width. Examples include *Borrelia duttoni* and *Borrelia vincenti*.
- leptospire, which are thin spirochaetes with many tightly packed coils that are difficult to distinguish. They measure 6–20  $\mu\text{m}$  in length by 0.1  $\mu\text{m}$  in width and have hooked ends. The leptospire of medical importance is *Leptospira interrogans* (contains many serovars).

*Note:* Diseases carried by medically important cocci, rods, vibrios and spirochaetes are summarized in Chart 7.4.

### Rickettsiae

Although classified as bacteria, rickettsiae resemble viruses in that they replicate only in living cells and are unable to survive as free-living organisms. They can just be seen with the light microscope (red particles in Giemsa preparations). Unlike viruses, rickettsiae contain both RNA and DNA, multiply by binary fission and have cell walls composed of peptidoglycan. They show sensitivity to antiseptics and some antibiotics.

*Note:* The important diseases caused by *Rickettsia* species and rickettsia-like microorganisms are described in subunit 7.18.35.

### Chlamydiae

Chlamydiae are small (250–500 nm) Gram negative bacteria but resemble viruses in being unable to replicate outside of living cells. They contain both

DNA and RNA and have their own enzyme systems. The energy required for metabolic activities is supplied by the host cell. Chlamydiae develop and reproduce in a special way. The infectious form is called an elementary body. Following infection of a host cell, the elementary body develops into a reticulate body. This reproduces by binary fission, producing microcolonies within a large cytoplasmic inclusion (chlamydial inclusion). Elementary particles are produced and released to infect new cells when the host cell ruptures (48–72 h after infection).

*Note:* The diseases caused by *Chlamydia* species are described in subunit 7.19.37.

### Prion particles

Neither bacteria nor viruses, prions are thought to be infectious self-replicating protein particles that cause a range of rare fatal degenerative neurological diseases (transmissible degenerative spongiform encephalopathies) which have long incubation periods. They include:

- Scrapie in sheep (disease known for many years).
- Bovine spongiform encephalopathy (BSE) in cattle.
- Kuru in humans (found only in Papua New Guinea, associated with ritual cannibalism, now a rare occurrence).
- Creutzfeld-Jakob disease (CJD) affecting mainly elderly people, and new variant CJD affecting younger people. Infection of brain tissue causes vacuolation of neurones with a sponge-like appearance of the tissue. Inflammatory cells are absent and there is no antibody response.

Prions are particularly resistant to heat and some chemical agents. They are inactivated by hypochlorite and by autoclaving at 134 °C for 18 minutes.

### Bacteria lacking cell walls

Four types of bacteria with deficient cell walls are recognized:

- *Mycoplasma* species
- L-forms
- Spheroplasts
- Protoplasts

**Mycoplasmas:** These are naturally occurring stable bacteria that lack a rigid cell wall. They are among the smallest living microorganisms capable of independent existence, ranging in size from 0.1–2  $\mu\text{m}$ . Species of medical importance include *Mycoplasma pneumoniae* and *Ureaplasma urealyticum*.

**L-forms:** These are mutant bacteria without a cell wall, usually produced in the laboratory but sometimes formed in the body

of patients being treated with penicillin. They can reproduce on ordinary culture media.

**Protoplasts:** These unstable cell deficient forms originate artificially. The cell wall is lost due to the action of lysozyme enzymes which destroy peptidoglycan. Protoplasts are metabolically active but unable to reproduce. They are easily lysed.

**Spheroplasts:** Derived from Gram negative bacteria, spheroplasts are bacteria with a damaged cell wall. The damage is caused by a toxic chemical or antibiotic such as penicillin. They are able to change back to their normal form when the toxic agent is removed.

### Reproduction of bacteria

Bacteria multiply by simple cell division known as binary fission (splitting into two). The single piece of double-stranded DNA reproduces itself exactly. The information required to make the cell's protein is encoded in the bacterial genome. Messenger (m) RNA is transcribed from the DNA chromosome and the proteins translated from the mRNA are assembled by the ribosomes. Several enzymes are involved in DNA replication and protein production. Bacterial mutations (chemical alteration in DNA) or transmissible bacterial variations involving gene transfer may occur in response to environmental changes.

### Gene transfer

Where fragments of chromosomal DNA from one bacterium are transferred into another bacterial cell by phage (virus that infects a bacterium) this is referred to as transduction. It can only occur between closely related bacterial strains. The main way genetic material can be exchanged between bacterial cells is by conjugation involving plasmids (see previous text). Less commonly, some bacteria are able to take up soluble DNA molecules from other closely related species directly across their cell wall (transformation).

When a bacterial species produces several forms each with its own characteristics, these variations are called strains.

### Cultural characteristics

Most medically important bacteria can be grown artificially in the laboratory provided the atmospheric conditions and temperature are correct and the culture medium used contains the required nutrients (described in detail in subunit 7.4).

Differences in the effect of oxygen on bacterial growth provide a further way of classifying bacteria:

- aerobes, which require free oxygen to grow,
- anaerobes, which are unable to grow in free oxygen,
- facultative anaerobes, which can grow in conditions in which oxygen is present or absent,
- microaerophiles which grow best in conditions of reduced oxygen concentration.

*Note:* Chart 7.3 is a basic classification of the medically important bacteria based on their Gram

reaction, morphology, whether they are sporing or non-sporing (Gram positive bacteria) and whether they are aerobes, facultative anaerobes, anaerobes, or microaerophiles. The diseases caused by these pathogens are summarized in Chart 7.4.

**Chart 7.3 Basic classification of medically important bacteria**

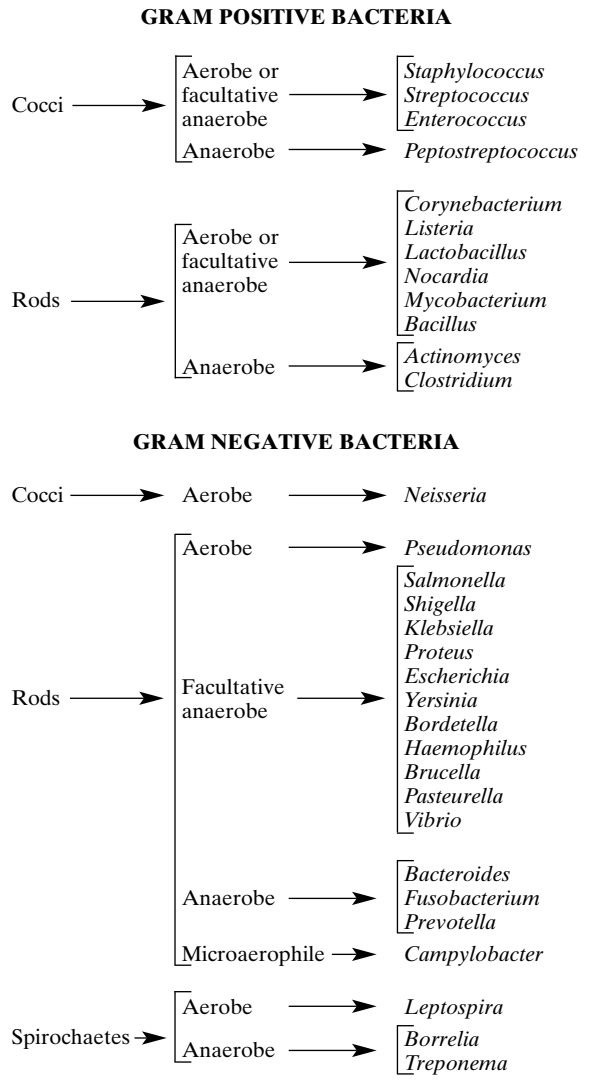

### Normal microbial flora

The normal microbial flora are those organisms that make their home on or in some part of the body. In a healthy person such organisms rarely cause disease. Microorganisms of the normal flora consist of symbionts, commensals, and opportunists.

**Symbionts:** These are organisms that usually benefit the person infected, e.g. the enteric bacteria that form part of the

normal flora of the intestine, assist in the synthesis of vitamin K and some of the vitamins of the B complex.

**Commensals:** These organisms form the largest group of the normal microbial flora of the body. They live on skin and the mucous membranes of the upper respiratory tract, intestines, and vagina. They are mostly neither beneficial nor harmful to their host, and can protect by competing with potential pathogens.

**Opportunists:** These are the organisms that can, if a suitable opportunity arises, become pathogenic and cause disease. Such an opportunity may arise following:

- The transfer of a commensal from its usual habitat to another part of the body where it can establish itself and cause disease, e.g. *Escherichia coli* is a normal inhabitant of the intestinal tract but if it enters the urinary tract it can cause urinary infection.
- The weakening of a person's natural immunity due to poor health, malnutrition, previous surgery, infection with HIV, or drug therapy, e.g. *Staphylococcus aureus* is a normal commensal in the nose but it may become a pathogen and cause pneumonia in a child with measles or influenza.

Opportunistic organisms are often the cause of what are called nosocomial infections, i.e. infections accidentally acquired by patients during a hospital stay due to their defence mechanisms being weakened.

Factors which influence the sites in the body selected by the organisms of the normal flora include temperature, pH, and available nutrients. When optimum conditions for the balanced growth of the body's normal flora become disturbed, for example, due to intensive broad spectrum antibiotic treatment, this can lead to those organisms not affected by the antibiotic increasing in numbers and causing ill health. The range of organisms that make up a person's normal flora is dependent on a number of factors including age, gender, hormonal activity, race, environment, diet and nutrition.

In the laboratory investigation of microbial infections, it is important to be aware of those sites in the body that are normally colonized by microorganisms because specimens originating from or collected via these sites are likely to contain commensals which can make it difficult to interpret cultures. One of the ways of preventing the growth of unwanted commensals is to use a selective culture medium (or selective and enrichment medium) which will inhibit the growth of commensals while supporting the growth of the pathogen(s) suspected of causing the infection.

Sites of the body having a normal microbial flora include the skin, axilla and groin, conjunctiva, external ear, mouth, nose and nasopharynx, large intestine, anterior urethra and vagina. The following text lists those specimens in which commensals are likely to be found and those specimens which in

health do not contain microorganisms and should not contain contaminants providing an aseptic collection technique and sterile container are used.

#### SPECIMENS CONTAINING COMMENSALS

- Sputum
- Throat and mouth specimens
- Nasopharyngeal and nasal specimens
- Eye discharges
- Skin and ulcer specimens
- Urogenital specimens
- Faeces and rectal swabs
- Urine (small numbers of commensals)

*Note:* The commensals which may be present in each specimen are listed in those subunits in which the examination of each specimen is described.

#### SPECIMENS NOT CONTAINING COMMENSALS\*

- Pus (wounds, abscesses, burns, sinuses)
- Cerebrospinal fluid
- Blood
- Serous fluids (synovial, pericardial, ascitic, hydrocele)

*\*Note:* Special care must be taken not to introduce contaminants into these specimens.

**Chart 7.4 Bacterial pathogens and diseases they cause**

<i>Disease</i>	<i>Bacterial pathogen</i>
RESPIRATORY INFECTIONS AND MENINGITIS	
Tuberculosis	<i>Mycobacterium tuberculosis</i>
Lobar pneumonia	<i>Streptococcus pneumoniae</i>
Bronchopneumonia	<i>Streptococcus pneumoniae</i> <i>Haemophilus influenzae</i> Occasionally <i>Staphylococcus aureus</i> and coliforms ( <i>E. coli</i> , <i>Proteus</i> , <i>Klebsiella</i> , <i>Pseudomonas</i> )
Atypical pneumonia	<i>Mycoplasma pneumoniae</i> <i>Coxiella burnetii</i>
Pneumocystis pneumonia	<i>Pneumocystis jiroveci</i>
Empyema	<i>Streptococcus pneumoniae</i> <i>Staphylococcus aureus</i>
Whooping cough (Pertussis)	<i>Bordetella pertussis</i> Occasionally <i>B. parapertussis</i>
Chronic bronchitis	<i>Haemophilus influenzae</i> <i>Streptococcus pneumoniae</i> Occasionally <i>Moraxella catarrhalis</i>
Acute epiglottitis (Croup syndrome)	<i>Haemophilus influenzae</i>
Sore throat (Pharyngitis)	<i>Streptococcus pyogenes</i> Post-streptococcal immunological complications include rheumatic fever and acute glomerulonephritis
Peri-tonsillar abscess	<i>Streptococcus pyogenes</i>

Ulcerative tonsillitis (Vincent's angina)	<i>Borrelia vincenti</i> and Gram negative anaerobes	Osteomyelitis	<i>Streptococcus pneumoniae</i> <i>Staphylococcus aureus</i> Occasionally <i>Haemophilus influenzae</i> , <i>Streptococcus pyogenes</i> , coliforms, <i>Mycobacterium tuberculosis</i> , <i>Brucella</i> species
Diphtheria	<i>Corynebacterium diphtheriae</i>		
Otitis media (middle ear infection)	<i>Haemophilus influenzae</i> <i>Streptococcus pyogenes</i> <i>Streptococcus pneumoniae</i> <i>Staphylococcus aureus</i> <i>Pseudomonas</i> species <i>Proteus</i> species <i>Bacteroides fragilis</i>		
Meningitis – pyogenic	<i>Neisseria meningitidis</i> <i>Streptococcus pneumoniae</i> <i>Haemophilus influenzae</i>  <i>Note:</i> Neonatal meningitis may also be caused by <i>Escherichia coli</i> , <i>Klebsiella</i> species, <i>Proteus</i> species, <i>Listeria monocytogenes</i> , and <i>Streptococcus agalactiae</i> (Group B).	DIARRHOEAL DISEASES	
– tuberculous	<i>Mycobacterium tuberculosis</i>	Bacillary dysentery	<i>Shigella</i> species
		<i>Campylobacter</i> enterocolitis	<i>Campylobacter jejuni</i> <i>Campylobacter coli</i>
		<i>Escherichia coli</i> dysentery	Enteroinvasive <i>E. coli</i> (EIEC) Enterohaemorrhagic <i>E. coli</i> (EHEC) Enteraggregative <i>E. coli</i> (EAEC)
		<i>Salmonella</i> enterocolitis	<i>Salmonella</i> serovars
		<i>Yersinia</i> enterocolitis	<i>Yersinia enterocolitica</i> (rare infection)
		Cholera	<i>Vibrio cholerae</i> O1, O139
		<i>Vibrio</i> gastroenteritis	<i>Vibrio parahaemolyticus</i>
		Infantile <i>E. coli</i> diarrhoea	Enteropathogenic <i>E. coli</i> (EPEC) Enterotoxigenic <i>E. coli</i> (ETEC) (also cause of traveller's diarrhoea)
		<i>Salmonella</i> food-poisoning	<i>Salmonella</i> serovars
		Clostridial food-poisoning	<i>Clostridium perfringens</i>
		Staphylococcal food-poisoning	<i>Staphylococcus aureus</i> (enterotoxin-producing strains)
		<i>Campylobacter</i> enteritis	<i>Campylobacter jejuni</i> <i>Campylobacter coli</i>
		<i>Bacillus</i> food-poisoning	<i>Bacillus cereus</i> and other species
		Antibiotic-associated diarrhoea (rare)	<i>Clostridium difficile</i> (may also cause pseudomembranous colitis)
		Botulism	<i>Clostridium botulinum</i> Disease caused by exotoxin in contaminated food
		Gastric and duodenal ulceration	<i>Helicobacter pylori</i>
		URINARY TRACT INFECTIONS (UTI)	
		Common cause	<i>Escherichia coli</i>
		Less common cause	<i>Proteus mirabilis</i> <i>Enterococcus faecalis</i> <i>Klebsiella</i> species
		UTI in sexually active women	<i>Staphylococcus saprophyticus</i>
		UTI associated with catheterization or instrumentation	<i>Staphylococcus aureus</i> <i>Pseudomonas aeruginosa</i> <i>Proteus Klebsiella</i>
		Renal tuberculosis	<i>Mycobacterium tuberculosis</i>
Ulcerative tonsillitis (Vincent's angina)	<i>Borrelia vincenti</i> and Gram negative anaerobes		
Diphtheria	<i>Corynebacterium diphtheriae</i>		
Otitis media (middle ear infection)	<i>Haemophilus influenzae</i> <i>Streptococcus pyogenes</i> <i>Streptococcus pneumoniae</i> <i>Staphylococcus aureus</i> <i>Pseudomonas</i> species <i>Proteus</i> species <i>Bacteroides fragilis</i>		
Meningitis – pyogenic	<i>Neisseria meningitidis</i> <i>Streptococcus pneumoniae</i> <i>Haemophilus influenzae</i>  <i>Note:</i> Neonatal meningitis may also be caused by <i>Escherichia coli</i> , <i>Klebsiella</i> species, <i>Proteus</i> species, <i>Listeria monocytogenes</i> , and <i>Streptococcus agalactiae</i> (Group B).		
– tuberculous	<i>Mycobacterium tuberculosis</i>		
<b>EYE INFECTIONS</b>			
Stye, blepharitis	<i>Staphylococcus aureus</i>		
Conjunctivitis	<i>Haemophilus influenzae</i> (pink eye) <i>Staphylococcus aureus</i> <i>Streptococcus pneumoniae</i>		
Neonatal eye infections	<i>Neisseria gonorrhoeae</i> <i>Chlamydia trachomatis</i> (D–K) <i>Staphylococcus aureus</i>		
Trachoma	<i>Chlamydia trachomatis</i> (A–C)		
<b>SEPTICAEMIA and BACTERAEMIA</b>			
Associated with generalized infection:	<i>Salmonella</i> Typhi, other <i>Salmonella</i> serovars <i>Neisseria meningitidis</i> (meningococcal septicaemia) <i>Mycobacterium tuberculosis</i> (HIV coinfection) <i>Yersinia pestis</i> (septicaemic plague) <i>Brucella</i> species <i>Listeria monocytogenes</i> (immunocompromised)		
Pathogens entering from localized infections:	<i>Haemophilus influenzae</i> <i>Staphylococcus aureus</i> <i>Streptococcus</i> species <i>Escherichia coli</i> <i>Salmonella</i> serovars (common with HIV coinfection) <i>Shigella dysenteriae</i> <i>Enterococcus</i> species <i>Pseudomonas</i> species <i>Proteus</i> species <i>Klebsiella</i> species <i>Bacteroides fragilis</i> <i>Clostridium perfringens</i>		
Bartonellosis	<i>Bartonella bacilliformis</i>		
<b>ARTHRITIS AND BONE INFECTIONS</b>			
Arthritis	<i>Staphylococcus aureus</i> <i>Neisseria gonorrhoeae</i> <i>Neisseria meningitidis</i>		



## SEXUALLY TRANSMITTED INFECTIONS

Venereal syphilis	<i>Treponema pallidum</i>
Gonorrhoea	<i>Neisseria gonorrhoeae</i>
Soft chancre	<i>Haemophilus ducrei</i>
Granuloma inguinale (donovanosis)	<i>Klebsiella granulomatis</i>
Lymphogranuloma inguinale	<i>Chlamydia trachomatis</i> (L1–L3)
Vaginosis	<i>Gardnerella vaginalis</i> and <i>Bacteroides</i>
Non-specific urethritis	<i>Chlamydia trachomatis</i> (D–K) <i>Ureaplasma urealyticum</i>
Pelvic inflammatory disease	<i>Neisseria gonorrhoeae</i> <i>Chlamydia trachomatis</i> (D–K)

## SKIN AND WOUND INFECTIONS

Boils, abscesses, styne pustules, carbuncles	<i>Staphylococcus aureus</i>
Impetigo	<i>Staphylococcus aureus</i> <i>Streptococcus pyogenes</i> Occasionally <i>Corynebacterium diphtheriae</i>
Erysipelas	<i>Streptococcus pyogenes</i>
Cellulitis	<i>Streptococcus pyogenes</i>
Wound infections	
– Surgical	<i>Staphylococcus aureus</i> <i>Escherichia coli</i> <i>Proteus</i> species <i>Klebsiella</i> species <i>Enterococcus</i> species <i>Pseudomonas aeruginosa</i> <i>Clostridium perfringens</i> <i>Bacteroides fragilis</i> Anaerobic cocci
– Puerperal sepsis and septic abortion	<i>Streptococcus pyogenes</i> <i>Streptococcus agalactiae</i> <i>Clostridium perfringens</i>
– Burns	<i>Streptococcus pyogenes</i> <i>Pseudomonas aeruginosa</i>
– Gas gangrene	<i>Clostridium perfringens</i> Occasionally <i>Clostridium novyi</i> , <i>Clostridium septicum</i>
Peritonitis	Coliforms, <i>Enterococcus</i> species, <i>Bacteroides fragilis</i> . Occasionally <i>Clostridium perfringens</i>
Tetanus	<i>Clostridium tetani</i>
Buruli ulcer	<i>Mycobacterium ulcerans</i>
Tropical ulcer	<i>Borrelia vincenti</i> with fusiform bacilli <i>Streptococcus pyogenes</i>
Leprosy	<i>Mycobacterium leprae</i>
Actinomycosis	<i>Actinomyces israeli</i>
Nocardiosis	<i>Nocardia asteroides</i>
Mycetoma (Madura foot)	<i>Nocardia brasiliensis</i> <i>Nocardia caviae</i>
Yaws (framboesia)	<i>Treponema p. pertenue</i>

Pinta *Treponema carateum*

## ZOOZOSES

Brucellosis	<i>Brucella</i> species
Plague	<i>Yersinia pestis</i>
Anthrax	<i>Bacillus anthracis</i>
Leptospirosis	<i>Leptospira interrogans</i>
Rat bite fever	<i>Spirillum minus</i> <i>Streptobacillus moniliformis</i>
Listeriosis	<i>Listeria monocytogenes</i>
Food-poisoning	<i>Salmonella</i> serovars <i>Campylobacter</i> species <i>Escherichia coli</i> (EHEC:0157)
Mesenteric adenitis, enteritis	<i>Yersinia pseudotuberculosis</i> <i>Yersinia enterocolitica</i>
Lyme disease	<i>Borrelia burgdorferi</i>
Tularaemia	<i>Francisella tularensis</i>
Q fever	<i>Coxiella burnetii</i>
Enteritis necroticans (Pigbel)	<i>Clostridium perfringens</i> (C)

## ARTHROPOD-BORNE INFECTIONS

Louse-borne relapsing fever	<i>Borrelia recurrentis</i>
Tick-borne relapsing fever	<i>Borrelia duttoni</i> and other <i>Borrelia</i> species
Epidemic typhus	<i>Rickettsia prowazekii</i> Vector: Louse
Endemic typhus	<i>Rickettsia typhi</i> Vector: Flea
Scrub typhus	<i>Orientia tsutsugamushi</i> Vector: Mite
Tick-borne typhus	<i>Rickettsia conorii</i> Vector: Tick
Rocky Mountain spotted fever	<i>Rickettsia rickettsii</i> Vector: Tick
Trench fever	<i>Bartonella quintana</i> Vector: Louse, Reservoir: Possibly rodent

Note: The laboratory features of the bacteria listed in this chart are described in subunits 7.18.1–7.18.37 and in the subsequent subunits describing the examination of specimens.

## FEATURES AND CLASSIFICATION OF VIRUSES

Features which make viruses different from other microorganisms are their small size, non-cellular structure, genome containing either deoxyribonucleic acid (DNA) or ribonucleic acid (RNA) but not both, and their inability to replicate outside of living cells. Because viruses replicate inside cells, fewer drugs are available to treat virus infections compared with bacterial infections, although vaccines are available against virus diseases such as influenza, yellow

fever, poliomyelitis, measles, mumps, rubella, hepatitis A and B, and rabies.

### Structure of viruses

Virus particles, or virions (infectious particles), are too small to be seen by the light microscope, measuring only 20–300 nm (0.02–0.3  $\mu\text{m}$ ). They can however be seen by the electron microscope (specialist virology laboratories).

All viruses consist of a mass (core) of nucleic acid (DNA or RNA) surrounded by a protective protein coat called a capsid. For RNA viruses, the genome can be single stranded, double stranded or fragmented. The genome of most DNA viruses is double stranded. The nucleic acid together with the capsid form the nucleocapsid. The capsid is antigenic and also contains the receptors which enable a virus to attach to the surface of its specific host cell. The capsid consists of a number of identical units called capsomeres. The symmetry, or pattern, of capsids is one of the features used to classify viruses.

#### Capsid symmetry

Capsid symmetry is described as being:

- Icosahedral in which the capsomeres are arranged to form a symmetrical icosahedron surrounding the nucleic acid. Small size (below 50 nm) icosahedral viruses appear spherical.
- Helical in which the capsomeres are arranged around a spiral of nucleic acid. Helical viruses can appear spherical, elongated, or filamentous.
- Complex, meaning the capsid symmetry is neither icosahedral nor helical.

#### Virus envelope

Many helical viruses and a few icosahedral viruses are surrounded by an envelope. This is a lipoprotein membrane composed of lipid and virus-specific glycoproteins (antigens) that project as spikes from the surface of the envelope. Compared with non-enveloped (naked) viruses, enveloped viruses are more sensitive to heat, detergents, and lipid solvents.

### Infection of cells by viruses

Because viruses possess neither a cellular structure nor organelles, they are dependent on their host cells for energy and replication. Outside of living cells, viruses are metabolically inert.

The information required for a virus to replicate is contained in its nucleic acid (genome). Following infection, a virus 'takes over' the synthesizing activities of its host cell, directing the cell to transcribe and, or, translate its genetic information to produce the protein and nucleic acid components required to

make new virions. Most DNA viruses replicate and are assembled in the nucleus of the host cell whereas most RNA viruses replicate and are assembled in the cytoplasm.

Mature virions are released from host cells either by rupture of the cell membrane as occurs with most unenveloped viruses, or by a process called budding in which enveloped virions are extruded from the cell membrane.

Viruses that infect bacteria are called bacteriophages, or phages. They infect only a narrow range of bacteria. They are important because they are able to transfer bacterial DNA from one bacterial cell to another and also incorporate viral DNA into the bacterial chromosome. This can result in bacteria producing new proteins, e.g. toxins. Bacteriophages that lyse bacteria are referred to as virulent phages. Phage typing using lytic phages can help to identify bacterial strains, e.g. salmonellae (in specialist bacteriology centres).

#### Effects of viruses on cells

When a virus infects a cell it usually replicates and causes the death of its host cell. The observable changes which lead to the death of a host cell are called cytopathic effects (CPE). These may include the formation of inclusion bodies (sites of virus replication) or syncytia (virus-infected cells fused together). In viruses cultured in the laboratory, CPE is observed by a shrinking or enlargement of infected cells, and the detachment of dead cells from the glass surface on which they are growing.

Occasionally, viruses infect cells and replicate without causing the immediate death of their host cells. New viruses are extruded through the cell membrane of the infected cells. Examples of such viruses include rubella virus, parainfluenza viruses, and hepatitis B virus.

Some viruses after infecting cells do not replicate, or they become active for a time and then become inactive (latent). Viruses that can cause latent infections include herpes viruses where viral nucleic acid remains in the cytoplasm of the host cell, and HIV where DNA copy of viral nucleic acid becomes part of the host cell genome. In response to certain stimuli, latent viruses can be reactivated and start to replicate.

Some viruses are able to change, or transform, their host cells from normal cells into tumour producing cells. Such viruses are said to have neoplastic, or oncogenic properties. RNA neoplastic viruses usually replicate in their transformed cells (without causing cytolysis) whereas DNA neoplastic viruses usually do not replicate in the cells they have transformed.

### Transmission of viruses

Human virus diseases are caused by:

- Viruses for which man is the natural or most important maintenance host.

*Examples:* rotaviruses, polioviruses, hepatitis viruses, HIV, rubella virus, rhinoviruses, measles virus, papillomaviruses, and several herpes viruses.

**Transmission routes for human viruses**

- By direct contact, e.g. sexually transmitted viruses such as HIV, herpes simplex virus 2, and hepatitis B virus.
- By ingesting viruses in food or water contaminated with faeces, e.g. enteroviruses, rotaviruses, and hepatitis A virus.
- By inhaling viruses in airborne droplets, e.g. influenza viruses, measles virus, adenoviruses, respiratory syncytial virus, and rhinoviruses. Overcrowding greatly assists in the spread of droplet infections.
- By contact with an article, such as a floor mat contaminated with papillomavirus (wart-producing virus) or a towel contaminated with a virus that causes eye infection.
- By a mother infecting her child during pregnancy, e.g. cytomegalovirus or rubella virus. Such infections may cause abortion, stillbirth, congenital abnormalities, or ill-health of the newborn. Hepatitis B virus and HIV can be transmitted from mother to baby during birth.
- By transfusion of virus infected blood, e.g. HIV 1 and 2, hepatitis B virus, and hepatitis C virus.

*Note:* Human viruses can also be carried from one person to another on the bodies of houseflies or bedbugs.

- Viruses for which arthropods (mosquitoes, sandflies, ticks) and vertebrate animals, especially rodents, birds, monkeys, are the natural or main reservoir hosts and humans only accidental or secondary hosts.

*Examples:* rabies virus, viruses that cause viral haemorrhagic fever, and the large number of arthropod-borne viruses which cause diseases such as yellow fever, dengue, and Rift Valley fever.

**Transmission routes for arthropod and animal viruses**

- By the bite of an infected, blood-sucking mosquito, sandfly, tick or midge. Arthropod-borne viruses are referred to as arboviruses although they belong to several different virus groups. They are major causes of fever, encephalitis and viral haemorrhagic fever (VHF) in tropical and developing countries (see later text).
- By the bite of an animal host, e.g. rabies virus is transmitted to man through the bite of an infected dog or other rabid animal.
- By man coming into contact with vegetation, food, or articles that have been contaminated with the excretions of infected animals, especially rodents, e.g. Lassa fever is transmitted via rodent urine. Infection can occur if the virus enters damaged skin, is inhaled in aerosols, or is ingested.
- By the direct transfer of viruses from one person to another, especially highly infectious viruses such as Ebola and Marburg viruses. The viruses are present in the saliva, urine and blood of infected persons.

Seasonal changes in climate can also influence the rate of transmission and spread of virus diseases, e.g. increases in mosquito numbers during the rainy season and times of flooding, increase the incidence of mosquito-borne infections such as dengue,

O'nyong, and Rift Valley fever. Lack of effective vector control, late response to epidemics, the creation of habitats that favour vector breeding or bring people into closer contact with vectors (e.g. deforestation or poorly planned irrigation schemes) are also important factors that increase the incidence and spread of arthropod-borne virus infections.

*Opportunistic virus infections*

Several viruses cause opportunistic infections in those with defective or inadequate immune responses, e.g. AIDS patients or those receiving treatment with immunosuppressive drugs. Such viruses include herpes simplex viruses (HHV-1, HHV-2), cytomegalovirus, varicella zoster virus, papovavirus, and HHV-8 which has been linked to Kaposi's sarcoma.

*Laboratory transmission of virus infections*

Laboratory transmission of viruses can occur by accidentally inhaling viruses in aerosols, ingesting viruses from contaminated fingers, or by viruses entering damaged skin (e.g. through cuts, scratches, insect bite wounds, eczematous areas) or accidentally through needle stick injuries or occasionally by contamination of the eye or membranes of the nose and mouth. Viruses can also be transmitted by way of contaminated laboratory coats.

To avoid laboratory infection with highly virulent and, or, infectious viruses such as Lassa, Marburg and Ebola viruses, Crimean-Congo virus, Kyasanur forest disease virus, and hepatitis B virus, every possible safety precaution must be taken when collecting, handling and testing specimens, especially blood, urine, body fluids and exudates. Specimens from patients with suspected viral haemorrhagic fever must be tested in a specialist virology laboratory with adequate containment facilities. Laboratory staff should know the effects of heat and chemical agents on viruses and which disinfectants are the most effective inactivating agents.

**Effects of physical and chemical agents on viruses**

- *Heat:* Most viruses are inactivated at 56 °C for 30 minutes or at 100 °C for a few minutes.

*Cold:* Viruses are stable at low temperatures. Most can be satisfactorily stored frozen although some viruses are partially inactivated by freezing and thawing.

- *Ultraviolet (UV) irradiation:* Inactivates viruses.
- *Chloroform, ether and other organic solvents:* Viruses surrounded by an envelope are inactivated. Unenveloped viruses are resistant (see Chart 7.5).
- *Oxidizing and reducing agents:* Chlorine, iodine, hydrogen peroxide, and formaldehyde, all inactivate viruses.

- *Phenols*: Most viruses are relatively resistant.
- *Virus disinfectants*: Include hypochlorite solutions and glutaraldehyde. Tissues, however, may protect viruses by quenching disinfectant.

**Classification of medically important viruses**  
Viruses are classified by their genome (RNA or DNA), morphology (capsid symmetry), size, presence or absence of an envelope and method of replication.

Chart 7.5

## RNA and DNA viruses of medical importance

RNA VIRUSES					
Family	Form/Size	Envelope	Viruses	Disease	Transmission to humans
<b>Togavirus</b>	Icosahedral 60–70 nm	+	Rubivirus	Rubella, congenital malformations	Respiratory droplets, transplacental
			<i>Alphaviruses</i> <ul style="list-style-type: none"> <li>• Chikungunya virus</li> <li>• Western and Venezuelan equine encephalitis viruses</li> <li>• Sindbis virus</li> <li>• Ross River virus</li> <li>• Mucambo virus</li> <li>• Mayaro virus</li> <li>• O'nyong-nyong virus</li> </ul>	Fever, arthritis, rash Fever, encephalitis Fever, rash Fever, arthritis, rash Fever Fever, rash Fever, arthralgia, rash	Mosquitoes
<b>Bunyavirus</b>	Helical 90–120 nm	+	<ul style="list-style-type: none"> <li>• Rift Valley fever virus</li> <li>• Hantaan virus</li> <li>• Crimean-Congo haemorrhagic fever virus</li> <li>• Hazara virus</li> <li>• Bunyamwera group</li> <li>• Bwamba group</li> <li>• C group</li> <li>• Guama group</li> <li>• Oropuche virus</li> <li>• Sandfly fever virus</li> </ul>	Fever, VHF VHF, renal disease, pulmonary syndrome Fever, VHF, rash VHF Fever Fever, encephalitis Fever	Mosquitoes Rodent saliva and urine Ticks Ticks Mosquitoes Mosquitoes Sandflies
			<ul style="list-style-type: none"> <li>• Hepatitis C virus</li> <li>• Hepatitis G virus</li> <li>• Dengue (1–4) viruses</li> <li>• Yellow fever virus</li> <li>• Japanese encephalitis virus</li> <li>• West Nile fever virus</li> <li>• Murray River virus</li> <li>• Rocio virus</li> <li>• Kyasanur Forest disease virus</li> </ul>	Hepatitis C (HCV), liver carcinoma Hepatitis G (HGV) Dengue, DHF, DSS Fever, jaundice, VHF Fever, encephalitis Fever, encephalitis, rash Fever, encephalitis Fever, VHF	Blood, sexual, mother to child Blood Mosquitoes Mosquitoes Ticks
<b>Flavivirus</b>	Complex 40–50 nm	+			
<b>Filovirus</b>	Helical 80 × 1000 nm	+	<ul style="list-style-type: none"> <li>• Marburg virus</li> <li>• Ebola virus</li> </ul>	VHF	Person to person (Rodents probably natural hosts)
			<ul style="list-style-type: none"> <li>• Lymphocytic choriomeningitis virus</li> <li>• Lassa virus</li> <li>• Machupo virus</li> <li>• Junin virus</li> <li>• Suanarito virus</li> </ul>	Meningitis VHF	Rodent urine Rodent urine
<b>Arenavirus</b>	Complex 50–300 nm	+			
<b>Rhabdovirus</b>	Helical 75–180 nm	+	• Rabies virus	Rabies	Bite of rabid animal (dog, wolf or bat)

<b>Paramyxovirus</b>	Helical 120–300 nm	+	● Morbillivirus (measles) virus	Measles	Respiratory droplets
			● Parinfluenza virus	Bronchiolitis, croup (infants), colds	
			● Mumps virus	Mumps	
			● Pneumovirus (respiratory syncytial virus)	Bronchiolitis and pneumonia (infants)	
<b>Orthomyxovirus</b>	Helical 80–120 nm	+	● Influenza A (including, new avian strain), B, C viruses	Influenza	Respiratory droplets
<b>Coronavirus</b>	Helical 60–220 nm	+	● Coronaviruses	Respiratory infection, common cold. SARS (severe acute respiratory syndrome)	Respiratory droplets
<b>Retrovirus</b>	Icosahedral About 100 nm	+	● HIV-1, HIV-2 viruses ● HTLV-1, II viruses	AIDS/HIV disease T cell leukaemia, lymphoma, paresis	Sexual, blood, mother to child As above
<b>Picornavirus</b>	Icosahedral 22–30 nm	–	● Hepatitis A virus	Hepatitis A (HAV)	Faecal–oral
			● Rhinoviruses	Colds	Respiratory droplets
			<i>Enteroviruses</i>		
			● Poliovirus, 1, 2, 3	Poliomyelitis encephalitis	Faecal–oral
			● Coxsackie A (1–24), B (1–6) viruses ● Echoviruses 1–34	Respiratory infection rash, meningo-encephalitis, myocarditis	Faecal–oral Respiratory droplets
● Enteroviruses 68–71	Respiratory disease, haemorrhagic conjunctivitis	Respiratory droplets			
<b>Reovirus</b>	Icosahedral 70–80 nm	–	● Rotavirus	Gastroenteritis	Faecal–oral
<b>Calicivirus</b>	Icosahedral 27–38 nm	–	● Hepatitis E virus	Hepatitis E (HEV)	Faecal–oral
			● Norwalk virus	Gastroenteritis	Faecal–oral

**DNA VIRUSES**

<b>Family</b>	<b>Form/Size</b>	<b>Envelope</b>	<b>Viruses</b>	<b>Disease</b>	<b>Transmission</b>
<b>Poxvirus</b>	Complex 250–400 nm	+	<i>Orthopox viruses</i>		
			● Variola virus	Smallpox (now extinct)	
			● Monkeypox virus	Mild smallpox-like disease	Contact with infected monkeys/squirrels
			● Cowpox virus	Ulcerating lesions	Milking infected cows
			<i>Parapox viruses</i>		
● Orf virus	Orf (pustular dermatitis)	Contact with infected sheep or goats			
			● Molluscum contagiosum virus	Skin nodules	Skin contact. Also opportunistic
<b>Herpesvirus</b>	Icosahedral 120–150 nm	+	<i>Human herpes viruses (HHV)</i> ● HHV-1 (herpes simplex virus 1)	Cold sores, oral and eye infections, encephalitis	Saliva skin contact

			<ul style="list-style-type: none"> <li>● HHV-2 (herpes simplex virus 2)</li> <li>● HHV-3 (varicella zoster virus)</li> <li>● HHV-4 (Epstein-Barr virus)</li> <li>● HHV-5 (Cytomegalovirus)</li> <li>● HHV-6</li> <li>● HHV-8 virus</li> </ul>	Genital herpes, neonatal infection Chickenpox, shingles Glandular fever Associated with Burkitt's lymphoma, nasopharyngeal carcinoma Glandular fever, congenital infection, disseminated infection in AIDS and immunocompromised, pneumonitis and hepatitis Roseola infantum, mononucleosis Associated with Kaposi's sarcoma	Sexual, mother to child Respiratory droplets, reactivation Oral, saliva Co-factors involved in tumour development Body fluids, transplacental Primary and reactivation Unknown
<b>Hepadnavirus</b>	Icosahedral About 42 nm	+	● Hepatitis B virus	Hepatitis B (HBV) acute and chronic, liver carcinoma	Blood, sexual, mother to child, close contact
<b>Deltavirus</b>	Helical About 37 nm	+	● Hepatitis D virus* * Found only in those infected with hepatitis B virus	Hepatitis D (HDV)	As for HBV
<b>Adenovirus</b>	Icosahedral 70–90 nm	–	● Adenoviruses 1–49	Sore throat, pneumonia, conjunctivitis	Respiratory droplets
<b>Papovavirus</b>	Icosahedral 45–55 nm	–	● Papillomavirus (70+)  ● JC virus	Warts, carcinoma of cervix, rectum, penis  Rare neurological disease in immunocompromised	Skin contact, genital  Opportunistic
<b>Parvovirus</b>	Icosahedral About 22 nm	–	● B19 virus	Childhood fever, rash (cheeks), aplastic crisis, hydrops fetalis	Respiratory route, transplacental

*Abbreviation:* VHF = Viral haemorrhagic fever symptoms, DHF = Dengue haemorrhagic fever, DSS = Dengue shock syndrome

**Further information:** For detailed information on the pathogenesis of virus infections and host responses, readers are referred to textbooks of clinical microbiology such as those listed under Recommended Reading at the end of this chapter. Further information on virus infections in tropical countries can be found in *Mansons Tropical Diseases*, 21st edition, 2003.

### **Virus diseases in tropical countries**

The following are among the virus diseases that can cause epidemics and, or, are important causes of ill-health and mortality in tropical and developing countries:

- HIV disease and AIDS
- Virus hepatitis (HAV, HBV, HCV)
- Dengue and dengue haemorrhagic fever
- Japanese encephalitis
- Viral haemorrhagic fever caused by Ebola virus, Marburg virus, Lassa virus and other viruses as listed in Chart 7.5
- Yellow fever
- Rift Valley fever
- Infections caused by herpes viruses
- Virus infections causing gastroenteritis, particularly in young children
- Measles

- Rabies
- Burkitt's lymphoma
- Poliomyelitis

**SARS (severe acute respiratory syndrome)** is caused by a newly identified coronavirus, SARS-CoV. Between 2002 (when SARS pneumonia was first reported from China) and 2004, more than 8400 people have been reported as having SARS with an estimated 910 persons having died from it. The virus is transmitted by infectious respiratory droplets. The incubation period is 2–12 days. Most infections have been in China, Taiwan, Singapore, Vietnam and Canada with international travel contributing to the rapid spread of the virus. An ELISA and western blot assay have been developed to detect antibodies to the virus.

*Note:* Based on the tests that can be performed in district laboratories, investigation of the following virus infections are included in this publication:

- HIV infection, described in subunit 7.18.55
- Hepatitis, described in subunit 7.18.54
- Dengue, described in subunit 7.18.53
- Examination of imprint smears for Burkitt's lymphoma cells, described in subunit 8.2.

Pathogenic arboviruses and viruses that cause viral haemorrhagic fever (some are arboviruses) are of particular importance in tropical countries.

**Arboviruses**

Arboviruses require an arthropod, e.g. mosquito, tick, or sandfly for their transmission. Their natural hosts include rodents, birds and monkeys. Arboviruses are classified into three main groups: alphavirus (formerly group A arboviruses) belonging to the family togavirus, flavivirus (formerly group B arboviruses) and bunyavirus. Those of importance in tropical countries are as follows:

**ALPHAVIRUSES**

<i>Mosquito-borne</i>	<i>Distribution</i>
● Western equine encephalitis virus	South America
● Venezuelan equine encephalitis virus	South America
● Mucambo virus	Brazil
● Mayaro virus	South America
● Chikungunya virus	Africa, India, Southeast Asia
● Sindbis virus	Africa, India, Southeast Asia
● Ross River virus	South Pacific
● O'nyong-nyong virus	Central Africa, East Africa

**FLAVIVIRUSES**

<i>Mosquito-borne:</i>	
● Dengue virus (4 types, see 7.18.53)	Latitude 30°N to 40°S
● Yellow fever virus	Africa, Central and South America
● Japanese encephalitis virus	Far East, Japan
● West Nile fever virus	Bangladesh, India Africa, India

- Murray River virus New Guinea
- Rocio virus Brazil

*Tick borne:*

- Kyasanur Forest disease virus India

**BUNYAVIRUSES**

*Mosquito-borne:*

- Rift Valley fever virus Africa
- Bunyamwera group\* Africa, South and Central America
- Bwamba group\* Africa
- C group\* South America
- Oropouche virus Central America
- Guama group\* Brazil
- South America

*Tick-borne:*

- Crimean-Congo haemorrhagic fever virus Africa, Central Asia
- Hazara virus Pakistan, Middle East
- Pakistan

*Sandfly-borne:*

- Sandfly fever virus Africa, Asia, Middle East

\*Details of the viruses in these groups can be found in *Mansons Tropical Diseases* (see Recommended Reading).

**Viruses causing viral haemorrhagic fever**

Viruses that cause viral haemorrhagic fever (VHF) include some arboviruses, arenaviruses and filoviruses as follows:

**ARBOVIRUSES** causing VHF

- Dengue virus (see also subunit 7.18.53)
- Rift Valley fever virus
- Yellow fever virus
- Kyasanur Forest virus
- Crimean-Congo haemorrhagic fever virus

*Note:* See above text for the distribution of these viruses.

**ARENAVIRUSES** causing VHF

*Transmitted by rodent excretions and contact with infected person:*

- |                                    |                         |
|------------------------------------|-------------------------|
| ● Lassa virus                      | West and Central Africa |
| ● Machupo virus (Bolivian VHF)     |                         |
| ● Junin virus (Argentinian VHF)    | South America           |
| ● Guanarito virus (Venezuelan VHF) |                         |
| ● Sabia virus                      |                         |

**FILOVIRUSES** causing VHF

*Transmitted from person to person (highly infectious)*

- Marburg virus\* East and South Africa
- Ebola virus\* Zaire, Sudan, Gabon, Ivory Coast

\*These viruses are known to infect monkeys but these are not thought to be the natural hosts (probably rodents).

Clinical features associated with infections caused by arboviruses and the listed arenaviruses and filoviruses

include (depending on virus), fever, rash, haemorrhagic symptoms (viruses that cause VHF), liver damage, encephalitis, and renal damage. Diseases to exclude when investigating serious arboviral and VHF infections include malaria, typhoid, brucellosis, plague, leptospirosis, septicaemia, bacterial meningitis, and rickettsial infections.

**Laboratory findings in encephalitis:** In the early stages of infection there is usually a low white cell count, followed by a mild leucocytosis with lymphocytosis. The cerebrospinal fluid is under pressure, the total protein is usually raised and up to  $1000 \times 10^6$  cells/litre ( $1000/\text{mm}^3$ ) may be found. The glucose concentration is not altered.

**Laboratory findings in VHF:** Haematological, biochemical and urine abnormalities are summarized in the following text:

*Haematological tests*

Haemoglobin .....	Reduced
Platelet count .....	Reduced
White cell count .....	Low
Blood film .....	Reactive lymphocytes <sup>1</sup>

*Coagulation tests*

Bleeding time .....	Prolonged
Clotting time .....	Prolonged
Prothrombin time .....	Prolonged
Partial thromboplastin time test .....	Prolonged
Fibrinogen .....	Low
FDP's .....	Raised <sup>2</sup>

*Biochemical tests*

Aspartate aminotransferase (AST) ..	Raised <sup>3</sup>
Serum bilirubin .....	Raised
Blood urea .....	Raised
Serum creatinine .....	Raised

*Urine tests*

Protein .....	Present
Haemoglobin or red cells .....	Detected
Microscopy .....	Granular casts and usually red cells

*Notes:* 1 In the later stages, there may be an increase in white cells. 2 Fibrin fibrinogen degradation products (FDPs) become raised when there is disseminated intravascular coagulation (DIC). 3 Other enzymes are also raised.

**Caution:** Strict safety precautions must be taken when handling, transporting and testing blood, secretions, urine and other specimens which may contain VHF viruses, particularly highly virulent viruses such as Ebola, Lassa, and Marburg. Protective gloves and a gown must be worn and where possible specimens should be handled in the laboratory in a safety cabinet. Needles, syringes, pipettes, and all glassware and other equipment used in collecting and testing the specimens must be safely decontaminated (see subunit 3.4 in Part 1

of the book). Any barrier (isolation) nursing procedures that are in place must be followed carefully by laboratory personnel when visiting the wards.

**Important:** District laboratory staff working in areas where VHF infections occur, should consult their regional or central public health laboratory regarding the safety procedures to follow when collecting, transporting, testing, and disposing of specimens, appropriate tests to perform, and the reporting of test results.

## BASIC FEATURES AND CLASSIFICATION OF FUNGI

Fungi are saprophytic, parasitic or commensal organisms. Most live in the soil on decaying matter helping to recycle organic matter. Unlike bacteria, fungi have a eukaryotic cell structure, i.e. their genetic material is differentiated into chromosomes which are enclosed by a nuclear membrane and the cell contains ribosomes and mitochondria. The cell wall consists of polysaccharides, polypeptides and chitin, and the cell membrane contains sterols which prevent many antibacterial antibiotics being effective against fungi. The majority of fungi are obligate aerobes and can be grown in the laboratory on simple culture media.

The study of fungi is called mycology. Fungi can be divided into:

- Yeasts
- Filamentous fungi, also referred to as moulds
- Dimorphic fungi (having yeast and filamentous forms)

### Yeasts

These are round, oval or elongate unicellular fungi, measuring 3–15  $\mu\text{m}$ . They reproduce by asexual budding. A daughter cell called a blastoconidia (often called a blastospore) is formed on the surface of the parent cell. Elongated budding cells often link together forming branching chains which are referred to as pseudohyphae. A few pathogenic yeasts form a capsule, e.g. *Cryptococcus neoformans*.

### Yeasts of medical importance

<i>Candida albicans</i>	<i>Malassezia furfur</i> *
<i>Cryptococcus neoformans</i>	<i>Trichosporon beigellii</i>

\*Can also co-exist in filamentous form.

### Moulds

These are multicellular fungi that form branching filaments called hyphae. A mass of interwoven hyphae is called a mycelium. The hyphae of many pathogenic moulds are septate, i.e. the hyphae are divided into cells by cross-walls called septa. Hyphae without



septa are referred to as aseptate (feature of zygomycetes). Moulds reproduce and survive adverse conditions by forming conidia and spores. These are of value in identifying species of fungi, especially following culture.

### Conidia

Various types of conidia are produced:

- angular or parcel-shaped arthroconidia (often referred to as arthrospores), formed directly from the hyphae by septation followed by hyphal fragmentation.
- thick walled, spherical, resistant chlamydoconidia (usually referred to as chlamydospores) formed from pre-existing cells in the hyphae, along the side, or at the tip of hyphae.
- small spherical unicellular microconidia (often seen in clusters) formed directly on the side of hyphae or at the end of a specialized hyphal strand called a conidiophore\*.
- large club or spindle-shaped macroconidia arising from the hyphal tip or wall and borne on a short or long conidiophore\*.

\* With some fungi, the conidiophore may branch into secondary segments called phialides. With *Aspergillus* species, the conidiophore ends in a swollen vesicle from which phialides bearing clusters of conidia develop. In *Penicillium* species the conidiophore branches into a structure called a penicillus with conidia being produced from phialides formed from secondary branches.

### Spores

Spores are produced either sexually after the fusion of nuclei followed by meiosis or asexually by mitosis. Many pathogenic fungi are 'imperfect', i.e. they are known only to produce vegetative non-sexual spores and conidia. Asexual spores called sporangiospores are produced by species of *Mucor*, *Absidia*, *Rhizopus* and other fungi of the class Zygomycota. The sporangiospores are produced within a sac-like structure called a sporangium which is borne on a sporangiophore. Zygomycetes also reproduce sexually forming zygospores. Fungi that have a sexual phase of reproduction in their life cycle are referred to as 'perfect fungi'.

### Moulds of medical importance

Dermatophytes	<i>Aspergillus</i> species
Fungi causing mycetoma	<i>Penicillium marneffeii</i>
Fungi causing chromomycosis	Zygomycetes: <i>Mucor</i> , <i>Absidia</i> , <i>Rhizopus</i> , <i>Basidiobolus</i> species

### Dimorphic fungi

These are fungi that are able to grow as yeasts or moulds depending on environmental conditions and temperature. The yeast form is found in infected tissue and when the fungus is cultured at 35–37°C and the filamentous form is found in the soil and when the fungus is cultured at ambient temperatures (20–30°C).

### Dimorphic fungi of medical importance

<i>Blastomyces dermatitidis</i>	<i>Paracoccidioides brasiliensis</i>
<i>Histoplasma</i> species	<i>Coccidioides immitis</i>
<i>Sporothrix schenckii</i>	

### Fungi of medical importance in tropical countries

Fungal infections are called mycoses. While fungal pathogens do not cause widespread or dangerous epidemics like bacteria and viruses, they are a major cause of individual distress, disability, and disfigurement, and the cause of severe life-threatening conditions in those with immunosuppression caused for example by AIDS or treatment with immunosuppressive drugs. The widest range and most serious of fungal infections and diseases caused by fungal toxins (mycotoxicoses) are found in tropical and developing countries. Heat, humidity, inadequate water supplies, poor living conditions, malnutrition, co-infection with HIV, and lack of diagnostic and care facilities for those with mycoses, all contribute to the high prevalence and severity of fungal infections in these countries.

Based on the sites of the body affected, the principal mycoses can be described as:

- *Superficial mycoses*, affecting the skin, hair or nails, e.g. dermatophytosis (ringworm) and pityriasis versicolor. They are confined to the body surfaces and do not directly involve living tissues.
- *Subcutaneous mycoses*, which are referred to as mycoses of implantation, e.g. mycetoma, chromomycosis, subcutaneous phycomycosis, rhinosporidiosis, and sporotrichosis. They are acquired when the pathogen is inoculated through the skin by minor cuts or scratches or by thorn or splinter wounds.
- *Systemic mycoses* which are often referred to as deep mycoses, e.g. histoplasmosis, blastomycosis, paracoccidioidomycosis, aspergillosis, and coccidioidomycosis. They are acquired by inhalation and may spread from the lung and involve any part of the body. Widespread infections can be fatal. Skin lesions are often present.

### Opportunistic mycoses

An increasing number of fungal species are being reported as causing infections, often severe and life-threatening in those with HIV disease and other conditions causing immunosuppression. While a few species form part of the normal microbial flora (e.g. *Candida* species), most opportunistic mycoses are caused by saprophytic fungi. The most widespread and, or, serious opportunistic mycoses are listed in Chart 7.6 and described in subunits 7.18.47–7.18.52.

### Mycotoxicoses

Mycotoxicoses are caused by ingesting mycotoxins in mouldy food, such as grain which has been stored

under damp humid conditions. The toxins are released by certain moulds as they grow, e.g. aflatoxins are produced by *Aspergillus flavus* when growing on peanuts and grains. Aflatoxin poisoning can cause hepatitis and hepatic carcinoma.

### Fungal allergies

Inhalation of fungal spores, particularly those of *Aspergillus*, can cause strong hypersensitivity reactions in susceptible persons previously sensitized, including asthma (type 1 immediate reaction) eosinophilia, and type 3 hypersensitivity skin reaction. Spores that germinate can lead to hyphae colonizing the bronchial tree (living tissue is not invaded), causing pneumonitis.

**Chart 7.6 Fungi of importance in tropical countries**

#### FUNGI CAUSING SUPERFICIAL MYCOSES

	<i>Disease</i>
• <i>Microsporum</i> species	Dermatophytosis (ringworm, tinea)
• <i>Trichophyton</i> species	
• <i>Epidermophyton floccosum</i>	
• <i>Malassezia furfur</i>	Pityriasis versicolor (tinea versicolor)

#### FUNGI CAUSING SUBCUTANEOUS MYCOSES

• <i>Phialophora</i> , <i>Fonsecaea</i> and <i>Cladosporium</i> species	Chromoblastomycosis (Chromomycosis) Mycetoma:
• <i>Madurella grisea</i>	– Black granule
• <i>Madurella mycetomatis</i>	– Dark red granule
• <i>Exophiala jeanselmei</i>	– Black granule
• <i>Leptosphaeria senegalensis</i>	– Black granule
• <i>Pseudallescheria boydii</i>	– White granule
• <i>Aspergillus nidulans</i>	– White-yellow granule
• <i>Basidiobolus</i> species	Subcutaneous zygomycosis
• <i>Rhinosporidium seeberi</i>	Rhinosporidiosis
• <i>Sporothrix schenckii</i>	Sporotrichosis

#### FUNGI CAUSING SYSTEMIC MYCOSES

• <i>Histoplasma capsulatum</i>	Histoplasmosis (classical)
• <i>Histoplasma C. duboisii</i>	African histoplasmosis
• <i>Blastomyces dermatitidis</i>	Blastomycosis
• <i>Paracoccidioides brasiliensis</i>	Paracoccidioidomycosis
• <i>Coccidioides immitis</i>	Coccidioidomycosis

#### FUNGI CAUSING OPPORTUNISTIC MYCOSES

• <i>Candida albicans</i> and related yeasts	Candidiasis
• <i>Cryptococcus neoformans</i>	Cryptococcal meningitis
• <i>Aspergillus</i> species	Aspergillosis
• <i>Pneumocystis jiroveci</i>	Pneumocystis pneumonia
• <i>Mucor</i> , <i>Absidia</i> , <i>Rhizopus</i> , <i>Rhizomucor</i> species	Mucormycosis (zygomycosis)
• <i>Penicillium marneffei</i>	Systemic penicilliosis
• <i>Histoplasma</i> species	Histoplasmosis
• <i>Sporothrix schenckii</i>	Sporotrichosis

Note: Features of these fungi and their laboratory identification can be found in subunits 7.18.38 to 7.18.52.

### LABORATORY DIAGNOSIS OF FUNGAL SPECIMENS

Many of the fungi that cause superficial and subcutaneous mycoses and some that cause systemic mycoses can be detected and occasionally identified microscopically:

- in wet specimen preparations, e.g. *Aspergillus hyphae* in sputum or *Cryptococcus neoformans* in cerebrospinal fluid (mixed with India ink or examined by dark-field microscopy).
- in potassium hydroxide (KOH) cleared specimens, e.g. dermatophytes (ringworm fungi) in skin scrapings, nails or hair.
- in stained preparations, e.g. *Candida albicans* in Gram stained smears of vaginal discharge or *Pneumocystis jiroveci* in Giemsa or other stained preparations of broncho-alveolar lavage or induced sputum.

#### Use of calcofluor white and fluorescence microscopy to demonstrate fungi

Calcofluor white (colourless) is a fluorochrome which can be used to detect rapidly, yeast cells, pseudohyphae, and hyphae in specimens when examined by fluorescence microscopy. The fluorochrome binds to the cellulose and chitin present in fungal cell walls. Depending on the wavelength of the exciter light, the fungi appear bright apple green or blue-white. When used to look for ringworm fungi, the calcofluor white can be mixed with potassium hydroxide. Calcofluor white (also known as *Fluorescent Brightner 28*, Code F 3543 from Sigma), is prepared by dissolving 1 g of the fluorochrome in 100 ml distilled water. From this a working solution is made by diluting 10 ml in 90 ml of 0.05% Evans blue stain. For use, 1 drop is mixed with 1 drop of 20% KOH (without dimethyl sulphoxide).

**Culture:** This is indicated when it is not possible to diagnose a serious fungal infection microscopically or a species identification needs to be established or confirmed. The appearances of fungal cultures, how quickly a fungus grows and at what temperature, and particularly the morphology of the conidia and spores produced, can help to identify fungal pathogens. Culturing of fungi is best carried out in a public health laboratory or specialist mycology centre where facilities exist for the safe handling of cultures and staff have training in mycological techniques and the recognition of fungal pathogens. District laboratory staff should request instructions from their mycology referral laboratory regarding the collection and sending of specimens for fungal culture. It may take several weeks before a culture report is received because some fungal pathogens are slow-growing.

**Biopsies** (preserved in 10%<sup>v/v</sup> formal saline, Reagent No. 38): Require processing and examining in a histopathological laboratory, e.g. for the diag-

nosis of histoplasmosis, rhinosporidiosis and sporotrichosis.

**Serology** Antibody tests are not often used to diagnose fungal infections due to cross-reactions, the inability of tests to demonstrate active infection, and inadequate antibody responses in severe immunosuppression. Several rapid and simple to perform immunological tests, however, have been developed to detect fungal antigen in specimens, e.g. antigen test to detect *Cryptococcus neoformans* antigen in c.s.f. and serum. (see subunit 7.18.48).

*Note:* In district laboratories, the main method of investigating fungal infections is the microscopical examination of specimens directly and in KOH and stained preparations.

## 7.3 Microscopical techniques used in microbiology

Information provided by microscopical techniques can often provide a rapid presumptive diagnosis of an infection, e.g. pulmonary tuberculosis using the Ziehl-Neelsen staining technique. Other techniques can help to identify a pathogen, e.g. the Gram staining technique can indicate whether an organism is Gram positive or Gram negative, a coccus or bacillus. Such information is particularly helpful when investigating diseases such as meningitis and gonorrhoea. Useful information can also be provided from the microscopical examination of wet preparations, e.g. when looking for motile vibrios in a faecal specimen or capsulated *C. neoformans* in cerebrospinal fluid (c.s.f.).

This subunit describes:

- Examination of pathogens in wet preparations
- How to prepare and fix smears prior to staining
- Precautions to take when staining smears
- Gram technique
- Ziehl-Neelsen technique to detect AFB
- Auramine-phenol technique to detect AFB
- Methylene blue technique
- Wayson's bipolar staining of bacteria
- Albert staining of volutin granules
- Giemsa technique
- Acridine orange fluorochrome staining.

*Other staining techniques*

- Toluidine blue-0 staining of *P. jiroveci* cysts is described in subunit 7.18.52.

- Polychrome Loeffler methylene blue staining of anthrax bacilli is described in subunit 7.18.6.

### 7.3.1 Examining pathogens in wet preparations

In district laboratories the examination of wet preparations is mainly used:

- to examine specimens and cultures for motile bacteria.
- to examine c.s.f. for capsulated yeast cells.
- to examine specimens for fungi.

#### Detecting motile bacteria

Knowing whether an organism is motile or non-motile can often assist in its identification, e.g. most serovars of *Salmonella* are motile whereas *Shigella* species are non-motile. *Vibrio* and *Campylobacter* species show a distinctive motility. The movement of spirochaetes is also characteristic.

#### *Technique using transmitted light microscopy*

The simplest way of examining a bacterial suspension for motile bacteria is as follows:

- 1 Place a small drop of suspension on a slide and cover with a cover glass. Avoid making the preparation too thick. It is advisable to seal the preparation with nail varnish or molten petroleum jelly to prevent it drying out.

*Hanging drop preparation:* Placing a drop of suspension on a cover glass and inverting this over a cavity slide or over a normal slide supported on a ring of plasticine is not recommended. Vibration of the fluid makes the preparation difficult to examine.

- 2 Examine the preparation microscopically for motile organisms, using the 10× and 40× objectives. Make sure the iris diaphragm of the condenser is *sufficiently closed* to give good contrast otherwise the organisms will not be seen. Bring the preparation into focus by focusing first on the edge of the cover glass.

*Note:* The movement of small motile bacteria must be distinguished from the on-the-spot vibratory movement (Brownian movement) which is shown by all microorganisms and particles when suspended in a fluid. True bacterial motility is the ability of an organism to move itself in different directions or a single direction.

*Dark-field microscopy*

Because the refractive index of unstained organisms in a fluid medium is not very different from the fluid medium which surrounds them, other forms of microscopy such as phase contrast and dark-field are recommended in preference to transmitted light microscopy when examining organisms in unstained wet preparations. Dark-field microscopy is required to detect *Treponema pallidum* spirochaetes in specimens.

The equipment for phase contrast microscopy is expensive and not usually found in district laboratories. Although the equipment needed to examine preparations by dark-field microscopy using a 100× objective is also expensive, a simple system which uses a dark-field stop is suitable for examining most specimens for motile bacteria, including spirochaetes (when using 10× and 40× objectives). The use of a dark-field stop and technique for examining wet preparations by dark-field microscopy are described on pp. 122–123 in Part 1 of the book.

*Note:* The identification of *Treponema pallidum* is described in subunit 7.18.32 and the examination of specimens and cultures for *Vibrio cholerae* is described in subunit 7.18.19.

**Examining wet preparations for capsulated organisms**

When cryptococcal meningitis is suspected, the examination of c.s.f. for capsulated yeast cells is an important investigation. Capsulated *C. neoformans* yeast cells are best detected in thin preparations of sediment from centrifuged c.s.f., using India Ink (Pelikan drawing ink) or dark-field microscopy (see subunit 7.18.48).

## 7.3.2 How to prepare and fix smears

If smears are to provide reliable information they must be prepared, labelled, and fixed correctly prior to being stained.

**Labelling slides**

Every slide must be labelled clearly with the date and the patient's name and number. Whenever possible, smears should be spread on slides which have one end frosted for labelling. With the increased use of such slides in recent years, their price is now little more than slides without a frosted

end. A lead pencil should be used for writing on the frosted area because pencil marks, unlike biro and grease pencil marks, will not be washed off during the staining process.

*Caution:* Slides from positive AFB smears should always be discarded and never reused. Scratched, chipped, and discolored slides should also be discarded.

**How to make smears**

Smears should be spread evenly covering an area of about 15–20 mm diameter on a slide. The precautions which should be taken when handling infectious material are described on pp. 61–64 in Part 1 of the book. The techniques used to make smears from different specimens are as follows:

- *Purulent specimen:* Using a sterile wire loop, make a thin preparation. Do not centrifuge a purulent fluid, e.g. c.s.f. containing pus cells.
- *Non-purulent fluid specimen:* Centrifuge the fluid and make a smear from a drop of the well-mixed sediment.
- *Culture:* Emulsify a colony in sterile distilled water and make a *thin* preparation on a slide. When a broth culture, transfer a loopful to a slide and make a *thin* preparation.
- *Sputum:* Use a piece of clean stick to transfer and spread purulent and caseous material on a slide. Soak the stick in a phenol or hypochlorite disinfectant before discarding it.
- *Swabs:* Roll the swab on a slide. This is particularly important when looking for intracellular bacteria such as *N. gonorrhoeae* (urethral, cervical, or eye swab). Rolling the swab avoids damaging the pus cells.
- *Faeces:* Use a piece of clean stick to transfer pus and mucus to a slide. Decontaminate the stick before discarding it. Spread to make a thin preparation.
- *Skin smears:* Making skin smears for *M. leprae* is described in subunit 7.18.30.

**Drying and fixing smears**

After making a smear, leave the slide in a safe place for the smear to air-dry, protected from dust, flies, cockroaches, ants, and direct sunlight. When a smear requires urgent staining, it can be dried quickly using *gentle* heat. Smears taken from in-patients and during out-patient clinics must always be transported to the laboratory in a covered container.

The purpose of fixation is to preserve microorganisms and to prevent smears being washed

from slides during staining. Smears are fixed by heat, alcohol, or occasionally by other chemicals. Microorganisms are not always killed by heat fixation, e.g. *M. tuberculosis*.

#### Heat fixation

This is widely used but can damage organisms and alter their staining reactions especially when excessive heat is used. Heat fixation also damages leucocytes and is therefore unsuitable for fixing smears which may contain intracellular organisms such as *N. gonorrhoeae* and *N. meningitidis*.

When used, heat fixation must be carried out with care. The following technique is recommended:

- 1 Allow the smear to air-dry completely.
- 2 Rapidly pass the slide, smear uppermost, three times through the flame of a spirit lamp or pilot flame of a Bunsen burner.

*Note:* After passing the slide through the flame three times, it should be possible to lay the slide on the back of the hand without the hand feeling uncomfortably hot. When this cannot be done, too much heat has been used.

- 3 Allow the smear to cool before staining it.

#### Alcohol fixation

This form of fixation is far less damaging to microorganisms than heat. Cells, especially pus cells, are also well preserved. Alcohol fixation is therefore recommended for fixing smears when looking for Gram negative intracellular diplococci. Alcohol fixation is more bactericidal than heat (e.g. *M. tuberculosis* is rapidly killed in sputum smears after applying 70% v/v alcohol).

A method of alcohol fixing smears is as follows:

- 1 Allow the smear to air-dry completely.
- 2 Depending on the type of smear, alcohol-fix as follows:
  - For the detection of intracellular Gram negative diplococci (*N. gonorrhoeae* or *N. meningitidis*), fix with one or two drops of absolute methanol or ethanol.
  - For the detection of other organisms including *M. tuberculosis*, fix with one or two drops of 70% v/v methanol or ethanol (absolute methanol can also be used but a 70% v/v solution is adequate).
- 3 Leave the alcohol on the smear for a minimum of 2 minutes or until the alcohol evaporates.

#### Other chemical fixatives

Other chemicals are sometimes necessary to fix

smears which contain particularly dangerous organisms to ensure all the organisms are killed, e.g. 40 g/l potassium permanganate is recommended for fixing smears which may contain anthrax bacilli.

Formaldehyde vapour is sometimes recommended for fixing smears which may contain *Mycobacterium* species. Formaldehyde fixed smears, however, tend to stain poorly and the chemical itself is toxic with an injurious vapour.

### 7.3.3 Precautions to take when staining smears

- Use a staining rack. Do not immerse slides in containers of stain because this can lead to contamination of stains and transfer of organisms from one smear to another.

*Staining rack:* This can be made by joining two pieces of glass or metal rod at each end with rubber or plastic tubing. The length of the rods will depend on the width of the sink or staining container.

*Caution:* When using a staining container/tray, empty it regularly to reduce the risk of fire from flammable chemicals.

- Do not attempt to stain a smear that is too thick. This is one of the commonest causes of poor staining and incorrect reporting of smears.
- To dispense stains, alcoholic and acetone reagents, use dropper bottles (e.g. TK type, see p. 167 in Part 1 of the book) or other spouted containers that can be *closed between use*. This will avoid evaporation, deterioration of stains and reagents and any build-up of toxic and flammable fumes in the laboratory.
- Label clearly stains and reagents. Indicate when a stain or reagent is *Toxic*, *Flammable*, or *Corrosive*. Write this on the dispensing container or use the appropriate biohazard symbol (see p. 75 in Part 1 of the book). Make sure flammable stains and reagents are kept well away from an open flame, e.g. from a lighted swab or flame of a spirit lamp or Bunsen burner. Use a tray to hold the dispensing bottles as this will help to contain any spillage of a reagent.
- Follow exactly a staining technique, particularly staining and decolorizing times, to ensure correct and reproducible staining reactions.
- When washing smears of c.s.f. sediment and other specimens which can be easily washed from a slide, direct the water from a wash bottle

on the *back* of the slide, not directly on the smear.

- After staining, place the slides at an angle in a draining rack for the smears to air-dry. Do not blot smears dry with filter or blotting paper (which is expensive and inappropriate to use). When a report is required urgently, dry a smear *carefully* over the pilot flame of a Bunsen burner or flame of a spirit lamp.
- To check staining results, use quality control smears of organisms, particularly when a new batch of stain is used (see subunit 7.1: *Control of stains and reagents*).

### 7.3.4 Gram technique

The Gram staining reaction is used to help identify pathogens in specimens and cultures by their Gram reaction (Gram positive or Gram negative) and morphology. Pus cells can also be identified in Gram smears.

**Gram positive bacteria:** Stain dark purple with crystal violet (or methyl violet) and are not decolorized by acetone or ethanol. Examples include species of:

*Staphylococcus*                      *Actinomyces*  
*Streptococcus*  
*Clostridium*  
*Corynebacterium*

**Gram negative bacteria:** Stain red because after being stained with crystal violet (or methyl violet) they are decolorized by acetone or ethanol and take up the red counterstain (e.g. neutral red, safranin, or dilute carbol fuchsin). Examples include species of:

*Neisseria*                      *Klebsiella*  
*Haemophilus*                *Brucella*  
*Salmonella*                 *Yersinia*  
*Shigella*                      Coliforms  
*Vibrio*

#### Gram reaction

Differences in Gram reaction between bacteria is thought to be due to differences in the permeability of the cell wall of Gram positive and Gram negative organisms during the staining process. Following staining with a triphenyl methane basic dye such as crystal violet and treatment with iodine, the dye-iodine complex is easily removed from the more permeable cell wall of Gram negative bacteria but not from the less permeable cell wall of Gram positive bacteria. Retention of crystal violet by Gram positive organisms may also be due in

part to the more acidic protoplasm of these organisms binding to the basic dye (helped by the iodine).

### Gram staining technique

#### Required

- Crystal violet stain<sup>a</sup>                      Reagent No. 28
- Lugol's iodine                              Reagent No. 53
- Acetone–alcohol decolorizer<sup>b</sup>        Reagent No. 1
- Neutral red, 1 g/l (0.1% w/v)<sup>c</sup>        Reagent No. 60

#### Notes

<sup>a</sup>Gentian violet or methyl violet can also be used.

<sup>b</sup>Some workers prefer to use acetone by itself, ethanol 95% v/v, or ethanol–iodine as the decolorizing solution. A mixture of acetone and alcohol is recommended because it decolorizes more rapidly than ethanol 95% v/v, and is less likely to over-decolorize smears than acetone without alcohol added.

<sup>c</sup>Neutral red is selected as the counterstain because it stains well gonococci and meningococci. Safranin can also be used. The use of dilute carbol fuchsin (1 in 10) is recommended for staining Vincents' organisms, *Yersinia*, *Haemophilus*, *Campylobacter*, and *Vibrio* species.

#### Method

- 1 Fix the dried smear as explained in subunit 7.3.2.  
*Note:* When the smear is for the detection of gonococci or meningococci, it should be fixed with methanol for 2 minutes (avoids damaging pus cells).
- 2 Cover the fixed smear with crystal violet stain for 30–60 seconds.
- 3 Rapidly wash off the stain with clean water.  
*Note:* When the tap water is not clean, use filtered water or clean boiled rainwater.
- 4 Tip off all the water, and cover the smear with Lugol's iodine for 30–60 seconds.
- 5 Wash off the iodine with clean water.
- 6 Decolorize rapidly (few seconds) with acetone–alcohol. Wash immediately with clean water.  
*Caution:* Acetone–alcohol is highly flammable, therefore use it well away from an open flame.
- 7 Cover the smear with neutral red stain for 2 minutes.
- 8 Wash off the stain with clean water.
- 9 Wipe the back of the slide clean, and place it in a draining rack for the smear to air-dry.
- 10 Examine the smear microscopically, first with the 40× objective to check the staining and to see the distribution of material, and then with the oil immersion objective to report the bacteria and cells.

**Results**

Gram positive bacteria . . . . .	Dark purple
Yeast cells . . . . .	Dark purple
Gram negative bacteria . . . . .	Pale to dark red
Nuclei of pus cells . . . . .	Red
Epithelial cells . . . . .	Pale red

**Reporting Gram smears**

The report should include the following information:

- Numbers of bacteria present, whether many, moderate, few, or scanty
- Gram reaction of the bacteria, whether Gram positive or Gram negative
- Morphology of the bacteria, whether cocci, diplococci, streptococci, rods, or coccobacilli. Also, whether the organisms are intracellular.
- Presence and number of pus cells
- Presence of yeast cells and epithelial cells.

**Example**

A urethral smear report might read:

‘Moderate numbers Gram negative intracellular diplococci and many pus cells.’

*Note:* Colour plates 7, 15, 24, 25, 28, 38, 43, 45, 48 show bacteria in Gram stained preparations.

**Variations in Gram reactions**

- Gram positive organisms may lose their ability to retain crystal violet and stain Gram negatively for the following reasons:
  - Cell wall damage due to antibiotic therapy or excessive heat-fixation of the smear.
  - Over-decolorization of the smear.
  - Use of an iodine solution which is too old, i.e. yellow instead of brown in colour (always store in a brown glass or other light opaque container).
  - Smear has been prepared from an old culture.
- Gram negative organisms may not be fully decolorized and appear as Gram positive when a smear is too thick.

*Control:* Always check new batches of stain and reagents for correct staining reactions using a smear containing known Gram positive and Gram negative organisms.

### 7.3.5 Ziehl-Neelsen technique for *M. tuberculosis* and *M. ulcerans*

Ziehl-Neelsen staining for *M. leprae* is described in subunit 7.18.30

The Ziehl-Neelsen (Zn) technique is used to stain *Mycobacterium* species including *M. tuberculosis*, *M. ulcerans*, and *M. leprae*. Mycobacteria, unlike most other bacteria, do not stain well by the Gram technique. They can however be stained with carbol fuchsin combined with phenol. The stain binds to the mycolic acid in the mycobacterial cell wall. After staining, an acid decolorizing solution is applied. This removes the red dye from the background cells, tissue fibres, and any organisms in the smear except mycobacteria which retain (hold fast to) the dye and are therefore referred to as acid fast bacilli, or simply AFB. Following decolorization, the smear is counter-stained with malachite green or methylene blue which stains the background material, providing a contrast colour against which the red AFB can be seen.

*Note:* Some actinomycetes, corynebacteria, and bacterial endospores are also acid fast.

**Differences between the acid fastness of *Mycobacterium* species**

- *M. tuberculosis* and *M. ulcerans* are strongly acid fast. When staining specimens for these species, a 3% v/v acid solution is used to decolorize the smears (as described in the following technique).
- *M. leprae* is only weakly acid fast. A 1% v/v acid decolorizing solution is therefore used for *M. leprae* smears and also different staining and decolorizing times as described in subunit 7.18.30.

‘**Acid and alcohol fast bacilli:** The acid decolorizing reagents used in the Zn staining technique also contain alcohol (ethanol). It is not true, however, that mycobacteria can be differentiated by whether they are acid fast or acid and alcohol fast. As Collins *et al* remark, ‘There is no basis for the old story that tubercle bacilli are acid and alcohol fast while other bacteria are only acid fast. Acid-fastness varies with the physiological state of the organisms. The alcohol in the decolorizing solution merely gives a cleaner stained smear’.<sup>1</sup>

**Hot and cold Zn techniques**

In the ‘hot’ Zn technique (as described in this publication), the phenolic-carbol fuchsin stain is heated to

enable the dye to penetrate the waxy mycobacterial cell wall. Techniques which do not heat the stain are referred to as 'cold' techniques. In these, penetration of the stain is usually achieved by increasing the concentrations of basic fuchsin and phenol and incorporating a 'wetting agent' chemical. Comparisons between the 'hot' and 'cold' methods have shown that both *M. leprae* and *M. tuberculosis* stain less well by the 'cold' method and stained smears fade rapidly.<sup>2</sup>

*Note:* In the paper of Ridley, MJ and Ridley, DS.<sup>3</sup> the authors report that after staining smears for leprosy bacilli at room temperature, examination was always difficult because of pallor. Where bacilli were few, some were missed altogether.

### Ziehl-Neelsen technique for *M. tuberculosis* and *M. ulcerans*

The preparation of sputum smears for the detection of *M. tuberculosis* is described in subunit 7.6, and cerebrospinal fluid preparation in subunit 7.13. In HIV-infected patients, AFB may be detected in buffy coat smears prepared from EDTA anticoagulated blood. The collection of ulcer material to detect *M. ulcerans* is described in subunit 7.18.29.

#### Required

- Carbol fuchsin stain (*filtered*) Reagent No. 21
- Acid alcohol, 3% v/v Reagent No. 4
- Malachite green, 5 g/l Reagent No. 55 (0.5% w/v)\*

\*If preferred, methylene blue, 5 g/l may be used instead of malachite green.

#### Method

- 1 Heat-fix the dried smear as described in subunit 7.3.2.

**Alcohol-fixation:** This is recommended when the smear has not been prepared from sodium hypochlorite (bleach) treated sputum and will not be stained immediately. *M. tuberculosis* is killed by bleach and during the staining process. Heat-fixation of untreated sputum will not kill *M. tuberculosis* whereas alcohol-fixation is bactericidal.

- 2 Cover the smear with carbol fuchsin stain.
- 3 Heat the stain until vapour *just* begins to rise (i.e. about 60°C). *Do not overheat.* Allow the heated stain to remain on the slide for 5 minutes.

**Heating the stain:** Great care must be taken when heating the carbol fuchsin especially if staining is carried out over a tray or other container in which highly flammable chemicals have collected from previous staining. Only a *small* flame should be applied under the slides using an ignited swab previously dampened with a *few* drops of acid alcohol or 70% v/v ethanol or methanol.

Do not use a large ethanol soaked swab because this is a fire risk.

- 4 Wash off the stain with clean water.  
*Note:* When the tap water is not clean, wash the smear with filtered water or clean boiled rain-water.
- 5 Cover the smear with 3% v/v acid alcohol for 5 minutes or until the smear is sufficiently decolorized, i.e. pale pink.  
*Caution:* Acid alcohol is flammable, therefore use it with care well away from an open flame.
- 6 Wash well with clean water.
- 7 Cover the smear with malachite green stain for 1–2 minutes, using the longer time when the smear is thin.
- 8 Wash off the stain with clean water.
- 9 Wipe the back of the slide clean, and place it in a draining rack for the smear to air-dry (*do not blot dry*).
- 10 Examine the smear microscopically, using the 100× oil immersion objective. When available, use 7× eyepieces because these will give a brighter image. Scan the smear systematically as shown in Fig. 7.2.

*Note:* Do not touch the smear with the end of the oil dispenser because this could transfer AFB from one preparation to another. After examining a positive smear, the oil must be wiped from the objective.

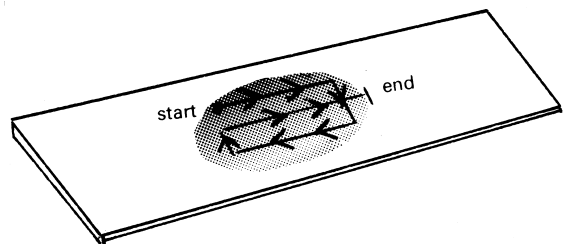

Fig 7.2 Method of examining a Ziehl-Neelsen stained sputum smear for AFB.

#### Results

AFB . . . . . Red, straight or slightly curved rods, occurring singly or in small groups, may appear beaded.

Cells . . . . . Green  
Background material . . . . . Green

*Note:* The appearance of *M. tuberculosis* in a Ziehl-Neelsen stained smear is shown in colour Plates 56 and 57.



**Reporting of sputum smears**

When any definite red bacilli are seen, report the smear as 'AFB positive', and give an indication of the number of bacteria present as follows:

More than 10 AFB/field . . . . . report +++  
 1–10 AFB/field . . . . . report ++  
 10–100 AFB/100 fields . . report +  
 1–9 AFB/100 fields . . . . report the  
 exact number

*When very few AFB are seen:* e.g. when only one or two AFB are seen, request a further specimen to examine. Tap water and deionized water (using 'old' resin) sometimes contain AFB that resemble tubercle bacilli, and occasionally stained scratches on a slide can be mistaken for AFB although these tend to be in a different focal plane from the smear. Occasionally AFB can be transferred from one smear to another when the same piece of blotting paper is used to dry several smears.

*When no AFB are seen after examining 100 fields:* Report the smear as 'No AFB seen'. Do not report 'Negative' because organisms may be present but not seen in those fields examined. Up to three specimens (one collected as an early morning specimen) may need to be examined to detect *M. tuberculosis* in sputum.

**Quality control**

At regular intervals, and *always* when a new batch of stain is started, two sputum smears of known high and low AFB positivity should be stained with the routine smears to check that the carbol fuchsin, staining method, and the microscopical examination of smears are satisfactory.

## REFERENCES

- 1 **Collins CH, Grange JM, Yates MD.** *Tuberculosis bacteriology*, 2nd edition, 1997. Butterworth Heinemann, ISBN 0 7506 2458 2.
- 2 **International Union Against Tuberculosis and Lung Disease (IUATLD).** *Technical Guide – Sputum examination for tuberculosis by direct microscopy in low income countries*, 5th edition, 2000.
- 3 **Ridley MJ, Ridley DS.** Stain techniques and morphology of *Mycobacterium leprae*. *Leprosy Review*, 42, pp. 88–95, 1971.

## 7.3.6 Auramine-phenol technique

The auramine-phenol fluorochrome staining technique can be used to detect *M. tuberculosis* in

sputum, cerebrospinal fluid, and other specimens when facilities for fluorescence microscopy are available. Compared with the Ziehl-Neelsen technique, the auramine-phenol fluorochrome technique enables a more rapid examination of smears because the 40× objective can be used. When tubercle bacilli are few they are more likely to be successfully detected in auramine-phenol stained smears.

**Auramine-phenol to demonstrate AFB**

Auramine fluoresces when illuminated (excited) by blue-violet or ultra-violet (UV) light. It can be used to demonstrate AFB because it binds to the mycolic acid in the mycobacterial cell wall. No heating of the stain is required. After being stained with auramine, the smear is decolorized with acid alcohol which removes the dye from the background. The smear is then washed with a weak solution of potassium permanganate to darken the background. Tubercle bacilli fluoresce white-yellow against a dark background.

*Note:* The principle of transmitted and incident fluorescence microscopy is described on pp. 123–125 in Part 1 of the book.

**Auramine-phenol fluorochrome staining technique****Required**

- Auramine-phenol stain                      Reagent No. 14 (filtered)
- 1% acid alcohol                              Reagent No. 3
- Potassium permanganate,                Reagent No. 70  
   1g/l (0.1% w/v)

**Method**

Whenever possible use a sodium hypochlorite technique to concentrate the bacilli prior to staining (see subunit 7.6).

- 1 Heat-fix the dried smear as described in subunit 7.3.2.
  - 2 Cover the fixed smear with the auramine-phenol stain for 10 minutes. Always include a positive control smear.
  - 3 Wash off the stain with clean water.
- Note:* When the tap water is not clean, wash the smear with filtered or clean boiled rainwater.
- 4 Decolorize the smear by covering it with 1% v/v acid alcohol for 5 minutes.

*Caution:* Acid alcohol is flammable, therefore use it with care well away from an open flame.

- 5 Wash off the acid alcohol with clean water.
- 6 Cover the smear with the potassium permanganate solution for about 10 seconds, followed by several rinses with clean water.

- 7 Wipe the back of the slide clean and place it in a draining rack for the smear to dry. Do not blot-dry. To prevent fading of the fluorescence, protect the stained smear from sunlight and bright light.
- 8 Systematically examine the smear for AFB by fluorescence microscopy using the 40× objective.

### Results

Acid fast bacilli (AFB) . . . . . White-yellow rods glowing against a dark background

### Reporting sputum smears

When fluorescent AFB (confirmed by Zn staining) are seen, report the smear as 'AFB positive', and give an indication of the number of bacilli present in plus signs (+ to +++).

When no fluorescent rods are seen, report the smear as 'No AFB seen'.

*Note:* Up to three specimens may need to be examined to detect the organisms.

### Quality control

Whenever a new batch of stain is started, two sputum smears of known high and low positivity should be stained with the routine smears to check that the auramine-phenol stain and staining technique are satisfactory. At least one positive control smear should be included each time smears are stained by the auramine-phenol technique.

### Availability of a low cost fluorescence microscopy system

The system shown in Plate 7.1 has been designed by Portable Medical Laboratories Inc. as a low cost easy

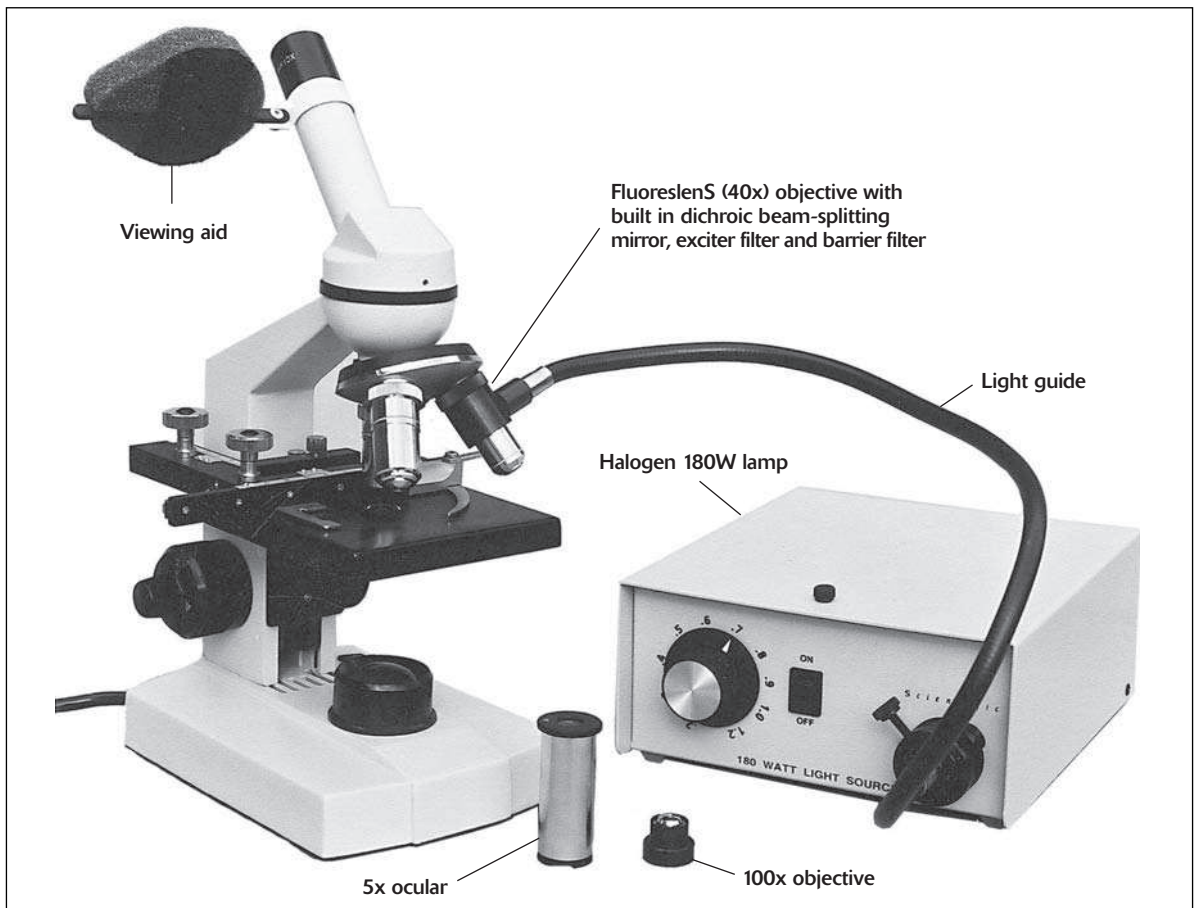

Plate 7.1 Low cost easy to use fluorescence system suitable for a wide range of fluorescence antibody techniques, including examining sputum smears for AFB. *Courtesy of WR Sanborn, Portable Medical Laboratories Inc.*

to operate fluorescence system. The specially constructed *FluoreslenS* objective attaches to a standard microscope. This houses the fluorescence dichroic mirror, exciter filter, and barrier filter. When used with the fibre optic light source (180 W halogen lamp), incident fluorescence microscopy can be performed to demonstrate AFB in sputum (auramine O fluorochrome) and a wide range of other fluorescence techniques.

#### Availability

The complete system is shown in Plate 7.1. Items are also available separately, e.g. *FluoreslenS* objectives (40× and 100×), 180 W quartz halogen lamp unit with fibre optic guide and light guide adaptors. Full details of the *FluoreslenS* fluorescence microscopy equipment can be obtained from Portable Medical Laboratories Inc. (see Appendix II).

### 7.3.7 Methylene blue technique

The methylene blue technique is a rapid method which can be used to show the basic morphology of bacteria and the bipolar staining of organisms. It is also useful for staining leucocytes in faecal preparations.

*Important:* Polychromed methylene blue (see text below) is required to stain the capsules of *Bacillus anthracis* (McFadyean's reaction), see subunit 7.18.6.

#### Required

Loeffler's methylene blue Reagent No. 51  
or  
Polychrome Loeffler methylene blue.

#### Methylene blue stains

Loeffler's methylene blue is an alkaline stain that can be easily prepared in the laboratory using methylene blue powder (Reagent No. 51). It can also be purchased ready-made from Merck/BDH or other manufacturers of stains.

When polychromed, Loeffler's methylene blue is suitable for staining the capsules of *B. anthracis* (McFadyean reaction). In its polychrome form, however, Loeffler's methylene blue is only available as a ready-made stain, not in powder form. It is, however, stable for several years if kept in a dark bottle out of direct light. It should be ordered as 'Methylene blue, McFadyean stain'.

What is referred to as 'Polychrome methylene blue' is available as a powder, but this is not suitable for staining *B. anthracis*. It is used mainly in the preparation of Romanowsky stains.

#### Method

1 Fix the dried smear as described in subunit 7.3.2.

When anthrax is suspected, fix the smear with potassium permanganate (Reagent No. 71) for 10 minutes.

2 Cover the smear with the stain for 1 minute.

*Note:* When staining anthrax bacilli, use Loeffler's polychrome methylene blue (see above text).

3 Wash off with clean water. When the tap water is not clean, use filtered water or clean boiled rain-water.

4 Wipe the back of the slide clean, and place it in a draining rack for the smear to air-dry.

5 Examine the smear microscopically, first with the 40× to see the distribution of material, and then with the oil immersion objective to look for bacteria.

#### Results

Bacterial cells . . . . . Blue  
Nuclei of leucocytes . . . . . Blue  
Capsular material . . . . . Mauve-purple  
(If polychrome Loeffler's stain has been used)

*Note:* *B. anthracis* is shown in colour Plate 55. Stained faecal leucocytes are shown in colour Plate 6.

### 7.3.8 Wayson's bipolar staining

Wayson's staining technique is a rapid method which shows clearly the bipolar staining morphology of bacteria such as *Yersinia pestis*.

#### Required

Wayson's stain Reagent No. 86

#### Method

1 Fix the dried smear as described in subunit 7.3.2.

2 Cover the smear with Wayson's stain for 10–20 seconds.

3 Wash off the stain with clean water. When the tap water is not clean, use filtered water or clean boiled rainwater.

4 Wipe the back of the slide clean, and place it in a draining rack for the smear to air-dry.

5 Examine the smear microscopically, first with the 40× objective to see the distribution of material

and then with the oil immersion objective to look for bipolar stained bacteria.

### Results

Bacteria . . . . . Blue with pink ends

*Note:* The bipolar staining of *Y. pestis* is shown in colour Plate 54 (Giemsa preparation).

## 7.3.9 Albert staining of volutin granules

The Albert technique is used to stain the volutin, or metachromatic, granules of *C. diphtheriae*. The granules are most numerous after the organism has been cultured on a protein-rich medium such as Dorset egg or Loeffler serum (see subunit 7.18.7).

*Note:* Metachromatic granules can also be found in other *Corynebacterium* species and occasionally in some *Bacillus* species. The presence of granules is of no significance regarding virulence.

### Required

- Toluidine blue-malachite green Reagent No. 83
- Albert's iodine Reagent No. 7

### Method

- 1 Fix the dried smear using alcohol (see subunit 7.3.2)
- 2 Cover the smear with the toluidine blue-malachite green stain for 3–5 minutes.
- 3 Wash off the stain with clean water. When the tap water is not clean, use filtered water or clean boiled rainwater.
- 4 Tip off *all* the water.
- 5 Cover the smear with Albert's iodine for 1 minute. Wash off with water.
- 6 Wipe the back of the slide clean, and place it in a draining rack for the smear to air-dry.
- 7 Examine the smear microscopically, first with the 40× objective to check the staining and to see the distribution of material and then with the oil immersion lens to look for bacteria containing metachromatic granules.

### Results

Bacteria cells . . . . . Pale green  
Metachromatic granules . . . . . Green-black

*Note:* An Albert stained smear of *C. diphtheriae* showing metachromatic granules is shown in colour in Plate 32.

## 7.3.10 Giemsa technique

Giemsa is a Romanowsky stain that is widely used in parasitology to stain malaria and other blood parasites. In microbiology, the Giemsa technique can be used to stain *Chlamydia trachomatis* inclusion bodies (see subunit 7.18.37), *Borrelia* species (see subunit 7.18.34), and when Wayson's stain is not available, to stain *Yersinia pestis* (see subunit 7.18.22). It is also used to stain *Histoplasma* species (see subunit 7.16.43), the internal bodies of *Pneumocystis jiroveci* cysts (see subunit 7.18.52), *Klebsiella granulomatis* (see subunit 7.10), *Penicillium marneffeii* (see subunit 7.18.50), and occasionally bacterial capsules.

*Note:* For staining chlamydiae, a weaker solution of Giemsa and a longer staining time are used (see following text).

### Required

- Giemsa stain Reagent No. 39
- Buffered water, pH 7.0–7.2 Reagent No. 20

### Method

- 1 Fix the dried smear by covering it with methanol (methyl alcohol) for 2–3 minutes. Allow the smear to air-dry.
- 2 Dilute the Giemsa stain in the buffered water as follows:
  - C. trachomatis*, dilute the stain 1 in 40:
    - Fill a small cylinder to the 19.5 ml mark with the buffered water.
    - Add 0.5 ml of Giemsa stain, i.e. to the 20 ml mark.
  - Other organisms*, dilute the stain 1 in 20:
    - Fill a small cylinder to the 19 ml mark with the buffered water.
    - Add 1 ml of Giemsa stain, i.e. to the 20 ml mark.
- 3 Place the slide, smear *downwards*, in a petri dish or other small container, supported on each side by a thin piece of stick.
- 4 Pour the diluted stain into the dish and cover with a lid.

*Note:* This inverted method of staining avoids stain being deposited on the smear.

- 5 Leave the smear to stain as follows:  
*C. trachomatis*, stain 1½–2 hours.  
*Other organisms*, stain 25–30 minutes.
- 6 Wash the stain from the dish and rinse the smear with buffered water.
- 7 Wipe the back of the slide clean, and place it in a draining rack for the smear to air-dry.
- 8 Examine the smear microscopically, first with the 40× objective to see the distribution of material and to select a suitable part of the smear to examine with the oil immersion lens.

### Results

#### *C. trachomatis*

Inclusion bodies	Blue-mauve to dark purple, depending on stage of development
Nuclei of host cells	Dark purple
Cytoplasm of host cells	Pale blue
Eosinophil granules	Red
Melanin granules	Black-green
Bacteria	Pale or dark blue

#### *Borrelia species*

<i>Borrelia</i> spirochaetes	Mauve-blue
Red cells	Mauve-blue
Nuclei of white cells	Dark purple
Cytoplasm of white cells	Pale blue or grey-blue

#### *Y. pestis*

Cocci bacilli	Blue with dark stained ends (bipolar staining)
---------------	--

*Note:* The appearance of *Y. pestis* is shown in colour Plate 54, *Borrelia* species in colour Plate 64, *C. trachomatis* in colour Plate 67, *K. granulomatis* in colour Plate 46, *P. marneffei* in colour Plate 71, and *P. jiroveci* in colour Plate 77.

## 7.3.11 Acridine orange technique

Acridine orange is a fluorochrome that causes deoxyribonucleic acid (DNA) to fluoresce green and ribonucleic acid (RNA) to fluoresce orange-red. It has been recommended for the rapid identification of *Trichomonas vaginalis*, yeast cells, and clue cells in vaginal smears. It can also be used to detect intracellular gonococci, meningococci, and other bacteria particularly in blood cultures.

### Required

- |   |                |
|---|----------------|
| – Acridine orange acid stain                      | Reagent No. 6  |
| – Alcohol saline solution                         | Reagent No. 9  |
| – Sodium chloride, 8.5 g/l (physiological saline) | Reagent No. 68 |

### Method

- 1 Cover the *unfixed* dried smear with the acridine orange acid stain for 5–10 seconds.  
*Note:* The acid fixative is contained in the stain.
- 2 Wash off the stain, and decolorize the smear with alcohol saline solution for 5–10 seconds.
- 3 Rinse the smear with physiological saline, and place the slide in a draining rack.
- 4 Add a drop of saline or distilled water to the smear, and cover with a cover glass.
- 5 Examine the smear by fluorescence microscopy using a BG 12 exciter filter and No. 44 and No. 53 barrier filters.

Examine first with the 10× objective to see the distribution of fluorescing material, and then with the 40× objective to identify *T. vaginalis* and to detect yeast cells, and bacteria.

### Results

<i>T. vaginalis</i> trichomonads	Orange-red with yellow-green nucleus
Yeast cells	Orange
Bacteria	Orange
Leucocytes (pus cells)	Yellow-green
Epithelial cells*	Yellow-green

\* In bacterial vaginosis, the orange staining bacteria adhering to the green epithelial cells (clue cells) can be clearly seen.

*Note:* The appearance of *T. vaginalis* in an acridine stained smear is shown in colour Plate 44.

**Further information:** The value of acridine orange in microbiology work and information on low cost fluorescence microscope systems can be obtained from Dr Warren Sanborn, Portable Medical Laboratories (see Appendix 11).

## 7.4 Culturing bacterial pathogens

The purpose of using cultural techniques in microbiology is to demonstrate the presence of organisms which may be causing disease, and when indicated, to test the susceptibility of pathogens to antimicrobial agents.

This subunit describes:

- Different types of culture media
- How to prepare, sterilize, and test culture media
- Sterilizing glassware used in culture work
- How to dispense culture media
- Inoculating plates, tubes, and bottles of culture media
- Incubation of inoculated media
- Reporting cultures

### DIFFERENT TYPES OF CULTURE MEDIA

For a culture medium to be successful in growing the pathogen sought it must provide all essential nutrients, ions, and moisture, maintain the correct pH and osmotic pressure, and neutralize any toxic materials produced. It is also essential to incubate the inoculated medium in the correct atmosphere, at the optimum temperature and for an adequate period.

The main types of culture media are:

- Basic
- Enriched
- Selective
- Indicator
- Transport
- Identification

**Basic media:** These are simple media such as nutrient agar and nutrient broth that will support the growth of microorganisms that do not have special nutritional requirements. They are often used in the preparation of enriched media, to maintain stock cultures of control strains of bacteria, and for subculturing pathogens from differential or selective media prior to performing biochemical and serological identification tests.

**Enriched media:** Enriched media are required for the growth of organisms with exacting growth requirements such as *H. influenzae*, *Neisseria* species, and some *Streptococcus* species. Basic media may be enriched with whole or lyzed blood, serum, peptones, yeast extract, vitamins and other growth factors. An enriched medium increases the numbers of a pathogen by containing all the necessary ingredients to promote its growth. Such a medium is often used for specimens collected from sites which are normally sterile to ensure the rapid multiplication of a pathogen which may be present only in small numbers.

**Enrichment media:** This term is usually applied to fluid selective media which contain substances that inhibit the growth of unwanted organisms, e.g. Rappaport-Vassiliadis broth which is often used as an enrichment medium for *Salmonella* serovars in faeces.

**Selective media:** These are solid media which contain substances (e.g. bile salts or other chemicals, dyes, antibiotics) which inhibit the growth of one organism to allow the growth of another to be more clearly demonstrated. A selective medium is used when culturing a specimen from a site having

a normal microbial flora to prevent unwanted contaminants overgrowing a pathogen. Media made selective by incorporating antibiotics are usually expensive.

*Other ways to select organisms*

Incubation conditions may be used to select organisms, e.g. *P. aeruginosa* is inhibited by anaerobic conditions. Also the pH of a medium may make it selective for a particular organism, e.g. *V. cholerae* can be isolated on an alkaline medium such as TCBS agar. Temperature may also help to select an organism e.g. *Listeria monocytogenes* can grow at 4°C whereas other organisms are inhibited. Growth, however, is slow.

**Indicator (differential) media:** These are media to which dyes or other substances are added to differentiate microorganisms. Many differential media distinguish between bacteria by incorporating an indicator which changes colour when acid is produced following fermentation of a specific carbohydrate e.g. MacConkey agar.

*Note:* Many media used to isolate pathogens are both selective and enrichment or both selective and differential.

**Transport media:** These are mostly semisolid media that contain ingredients to prevent the overgrowth of commensals and ensure the survival of aerobic and anaerobic pathogens when specimens cannot be cultured immediately after collection. Their use is particularly important when transporting microbiological specimens from health centres to the district microbiology laboratory or specimens to the Regional Public Health Laboratory. Examples of transport media include Cary-Blair medium for preserving enteric pathogens and Amies transport medium for ensuring the viability of gonococci.

**Identification media:** These include media to which substrates or chemicals are added to help identify bacteria isolated on primary cultures. Examples include peptone water sugars, urea broth, and Kligler iron agar. Organisms are mainly identified by a change in the colour of the medium and or the production of gas. Organisms used to inoculate identification media must be first isolated in pure culture.

### Choice of culture media

The choice of culture media to use in microbiology laboratories will depend on:

- The major pathogens to be isolated, their growth requirements, and the features by which they are recognized.
- Whether the specimens being cultured are from sterile sites or from sites having a normal microbial flora. Although a selective medium is usually more expensive than a non-selective one, it often avoids subculturing, isolates a pathogen more quickly, and makes it easier to differentiate and interpret bacterial growth.
- Cost, availability, and stability of different media in tropical countries.
- Training and experience of laboratory staff in preparing, using, and quality controlling culture media.

**Solid, semi-solid and fluid culture media**

Culture media can be classified by consistency as:

- Solid
- Semi-solid
- Fluid

*Solid culture media*

Media are solidified by incorporating a gelling agent such as agar or gelatin.

**Agar**

Agar (polysaccharide extract obtained from seaweed) is commonly used to solidify culture media because of its high gelling strength, its setting temperature of 32–39°C and melting temperature of 90–95°C. Most agars used in bacteriological work produce a firm gel at an agar concentration of 1.5% w/v. The low gelling temperature allows heat-sensitive nutrients such as whole blood to be added safely at 45–50°C. At a concentration of 0.4–0.5% w/v, agar is added to transport media such as Amies medium to give a semisolid gel.

Solid media are used mainly in petri dishes as plate cultures. Also in bottles or tubes as stab (deeps) or slope cultures. The inoculation of plates, slopes and deeps is described later in this subunit. The purpose of culturing on solid medium is principally to isolate discrete colonies of each organism present in the specimen. This will enable pure cultures to be produced for identification and sensitivity testing. The colonial appearances and changes in the media made by colonies may provide valuable identification information.

**Appearances of bacterial colonies on solid media**

Bacterial colonies should be examined in a good light. Use oblique lighting when examining for iridescent colonies. A low power magnifying lens can help to see morphological detail.

*When viewed from above:* Colonies may appear round, irregular, crenated, or branching. They may be transparent or opaque and their surface may be smooth or rough, dull or shiny. The colonies of capsulated species appear mucoid. Mature colonies of pneumococci have a ringed appearance.

*When viewed from the side:* Colonies may appear flat or raised in varying degrees sometimes with bevelled edges or with a central elevation or depression.

*When touched with a wire loop:* Some colonies are soft and easily emulsified such as *Staphylococcus aureus*, whereas others are difficult to break up such as *Streptococcus pyogenes*.

*The colour of colonies:* This also helps to identify bacteria, especially when using differential media containing indicators.

**Changes which may occur in the medium when bacteria are cultured on solid agar**

These include haemolytic reactions, pigment production, colour changes surrounding carbohydrate fermenting colonies, and blackening due to hydrogen sulphide production.

*An example of a pigment forming organism is *Pseudomonas aeruginosa* which produces a yellow-green colour in media such as blood agar and MacConkey agar.*

*An example of an organism that produces a colour change is *Vibrio cholerae* which is sucrose-fermenting, giving a yellow colour in TCBS agar. Blackening due to hydrogen sulphide production is seen with many salmonellae cultured in Kligler iron agar.*

*Haemolytic reactions in blood agar are seen with beta-haemolytic streptococci and alpha-haemolytic pneumococci. Morphological appearances of colonies can vary depending on the species of blood used, e.g. horse, sheep, or goat blood.*

*Semi-solid culture media*

This form of culture medium is prepared by adding a small amount of agar (0.4–0.5% w/v) to a fluid medium. Semi-solid media are used mainly as transport media, and for motility and biochemical tests.

*Fluid culture media*

Fluid media are most commonly used as enrichment where organisms are likely to be few e.g. blood culture. Some organisms produce a surface growth on the medium in which they are growing e.g. *Vibrio cholerae* when growing in alkaline peptone water. Fluid media may also be used for biochemical testing e.g. peptone water sugars or the use of media containing tryptophan to detect indole production by some enterobacteria. A good inoculation technique is important as the introduction of a single contaminating organism may produce an incorrect result. The inoculation of a fluid culture medium is described later in this subunit.

**HOW TO PREPARE, STERILIZE, AND TEST CULTURE MEDIA**

If pathogens are to be isolated successfully, standard operating procedures (SOPs) are needed which detail for each culture medium used in the laboratory, its purpose, from where it can be obtained, its preparation, and how it is sterilized, dispensed, labelled, stored and performance tested.

**SOPs:** General guidelines on how to prepare SOPs can be found in subunit 2.4 in Part 1 of the book.

**Use of dehydrated culture media**

In the preparation of complex culture media, it is advisable for district laboratories to use ready-made standardized dehydrated media to ensure good performance and reproducibility. In most instances it will also be less expensive than buying the individual chemical constituents. Some chemicals may also be difficult to obtain, not available in small amounts, and may have a short shelf-life.

Dehydrated media is hygroscopic, i.e. it absorbs water. When exposed to moisture, it *rapidly* becomes unfit for use. A hard mass is formed which alters the chemical and microbiological properties of the medium. This can be a serious problem for tropical countries with humid climates. Adequate precautions must be taken to prevent dehydrated culture media deteriorating and having to be discarded before it is finished. Such precautions include:

- Weighing the medium rapidly, and tightly capping the bottle *as soon as possible* after removing the approximate amount. Do not return small amounts of medium to the stock bottle (it is best to close the bottle quickly). Whenever possible, use containers or tubes that have been pre-marked to hold the amount required. This will reduce the time the culture medium container needs to be open.

For media available only in large quantities and supplied in wide-necked containers, it may be advisable to transfer the media into several containers (clean sterile with air-tight caps, and clearly labelled) to avoid the stock container being opened repeatedly and absorbing moisture.

- Sealing the cap of the container with adhesive tape. When the cap cannot be easily taped, seal the container in an airtight plastic bag (squeeze out most of the air before sealing the bag).
- Storing media in the coolest *driest* place available and always out of sunlight, e.g. do not store dehydrated media in the same room as used for steam sterilizing, boiling materials, or cleaning glassware etc.

*Important:* Whenever possible, the Central or Regional Public Health Laboratory should supply district laboratories with ready-made or easy to make culture media. This will promote standardization and enable media to be purchased economically in 500 g amounts.

To minimize costs, the different types of media should be kept to a minimum, e.g. the same medium can be used to prepare blood agar, the base medium used to make a selective medium to isolate *N. gonorrhoeae*, and to make the agar slope in blood culture media. Columbia agar is recommended.

When culture media are purchased by the Central or Regional Laboratory, it is more efficient and cost-effective for the purchasing laboratory to

perform the required quality control of each culture medium prior to its distribution to district laboratories.

### Preparation of culture media

Full details of the preparation and quality assurance of all culture media used in the laboratory must be included in SOPs and a record kept of stock items, sources of materials, and the dates when different media are prepared.

The following are important when preparing culture media:

- As discussed previously, prepare media made from dehydrated products in as damp-free an environment as possible. To prevent the risk of inhaling fine particles of dehydrated media, wear a dust mask while handling dehydrated media. powder or use granulated media (granulated culture media are available from Merck, see Appendix 11).
  - Wash the hands immediately after preparing media.
  - Once the ingredients are weighed, do not delay in making up the medium. Follow exactly the manufacturer's instructions.
  - Use completely clean glassware, plastic or stainless steel equipment that has been rinsed in pure water. The container in which the medium is prepared should have a capacity of at least twice the volume of the medium being prepared.
  - Use distilled water from a glass still. Deionized water can also be used providing the exchange resins do not contain substances inhibitory to bacteria (preparation of deionized and distilled water in district laboratories is described in subunit 4.4 in Part 1 of the book).
- Water containing chlorine, lead, copper, or detergents must not be used. Besides containing substances harmful to bacteria, impure water can alter the pH of a medium or cause a precipitate to form.
- Add the powdered or granular ingredients *to* the water and stir to dissolve. Do not shake a medium but mix by stirring or by rotating the container.
  - When heating is required to dissolve the medium, stir while heating and control the heat to prevent boiling and foaming which can be dangerous and damage the medium, e.g. DCA or TCBS agar. Overheating a medium can alter its nutritional and gelling properties, and also its pH.
  - Autoclave a medium only when the ingredients are *completely dissolved*. Always autoclave at the



correct temperature and for the time specified (see later text).

- Dispense medium in bottles or tubes in amounts convenient for use. Know the length of time prepared media can be stored without deteriorating (take into account storage temperature).

### **Checking the pH of a culture medium**

The pH of most culture media is near neutral. An exception is alkaline peptone water. The simplest way of testing the pH of a culture medium is to use narrow range pH papers or a pH meter (see pp. 173–174 in Part 1 of the book).

A fluid medium can be tested by dipping a narrow range pH paper into a sample of the medium when it is at room temperature and comparing the colour of the paper against the pH colour chart provided. An agar medium can be tested by pouring a sample of the molten medium into a small beaker or petri dish and when it has solidified, laying a narrow range pH paper on its surface. The colour of the paper is then compared against the pH colour chart.

The pH of a dehydrated medium should not require adjustment providing it has been prepared correctly using pure water and clean equipment, and it has not been over-autoclaved. The manufacturer's instructions *must be followed exactly*.

The pH of other media should be adjusted as directed in the method of preparation. Minor adjustments should be carried out using 0.1 mol/l (N/10) sodium hydroxide when the medium is too acid, and 0.1 mol/l (N/10) hydrochloric acid when too alkaline. Use 1 mol/l (1N) sodium hydroxide (Reagent No. 75) to adjust the pH of alkaline peptone water.

When adjusting the pH of a large volume of medium it is best to measure the amount of acid that needs to be added to adjust 10 ml of the medium, and then calculate the amount required to adjust the remaining volume.

### **Sterilizing culture media**

The following methods are used to sterilize culture media:

- Autoclaving
- Steaming at 100 °C
- Filtration

### **Autoclaving**

The majority of culture media are sterilized by being autoclaved. This ensures the destruction of bacterial endospores as well as vegetative cells.

It is important to sterilize a medium at the correct temperature and for the correct length of time as

instructed in the method of preparation. Under-autoclaving can result in an unsterile medium which will need to be discarded. Over-autoclaving can cause precipitation, alteration of pH, and the destruction of essential components in a medium.

*Note:* The principles of autoclaving, the specifications of autoclaves and pressure cookers appropriate for use in district laboratories, and how to autoclave culture media safely and correctly are described in subunit 4.8 in Part 1 of the book.

### **Steaming at 100 °C**

This is used to sterilize media containing ingredients that would be broken down or inactivated at temperatures over 100 °C, e.g. Cary-Blair transport medium. Steaming is also used to re-melt previously bottled sterile agar media.

Steaming can be performed in an autoclave with the lid left loose, or in any form of steam sterilizer such as an Arnold or Koch steamer. The bottles of media with loosened caps are placed on perforated trays above the boiling water. After sterilization and the medium has cooled, the bottle tops are tightened. Steaming times vary according to the type of medium, e.g. 15 minutes for Cary-Blair medium.

### **Filtration**

This provides a means of removing bacteria from fluids. It is used mainly to sterilize additives that are heat-sensitive and cannot be autoclaved, or less stable substances that need to be added to a sterile medium immediately before it is used. Examples include serum and solutions containing urea and certain carbohydrates.

Several different types of filters can be used including those made from sintered glass or inert cellulose esters. Cellulose filters are referred to as membrane filters. They are preferred to other types of filters because they filter more rapidly, do not affect the filtrate in any way, and absorb very little of the substance being filtered.

Membrane filters are particularly suitable for filtering small volumes of fluid because they can be placed in a Swinnex type filter holder which can be attached to a syringe as shown in Plate 7.2. Swinnex filter holders are available to take membrane filters of diameter sizes 13 mm, 25 mm, and 47 mm. Swinnex holders made from polypropylene and polycarbonate can be autoclaved and used many times. Membrane filters made from cellulose nitrate are also autoclavable. They are available in a variety of pore sizes, with 0.22 µm being required for sterile filtration. The fluid being filtered should be relatively clear to pass through a 0.22 µm porosity

filter. Cloudy fluids should first be passed through a less fine filter.

**Availability:** Autoclavable polypropylene filter holders (25 mm diameter) and cellulose nitrate membranes (25 mm diameter 0.22  $\mu\text{m}$  porosity) can be obtained from Millipore Corporation (see Appendix 11). Membranes are available in pore sizes from 0.025  $\mu\text{m}$  to 8  $\mu\text{m}$ . A range of autoclavable filter holders suitable for sterilizing larger volumes of fluid by membrane filtration are also available from Millipore Corporation.



Plate 7.2 Autoclavable Swinnex filter holders attached to syringes. Courtesy of Millipore Corporation.

### Sterility testing

Sterility test routinely media to which blood or other substances have been added after autoclaving. For 'sterile' media in screw-cap tubes or bottles, the simplest way to test for contamination is to incubate 5% of the batch at 35–37°C overnight. Contamination by microorganisms capable of overnight growth, will be shown by a turbidity in a fluid medium and growth on or in a solid medium. Media in petri dishes are best examined for contamination immediately before use.

**Important:** All media, even those that have been sterility tested at the time of preparation, should always be checked visually immediately before being inoculated for any change in appearance that could indicate contamination or deterioration. This is particularly important during the hot season and when the humidity is high.

### Performance testing

Whenever possible, the Central or Regional microbiology laboratory should supply district laboratories

with standardized tested media. When this is not possible, each district laboratory should set up its own quality control of the media it prepares. A set of control organisms (stable stock strains) will need to be obtained from the Regional or Central Public Health Laboratory (or from a commercial source)\* and these organisms maintained with regular sub-culturing as indicated in Chart 7.7.

#### \*Sources of well-characterized stable strains of control bacteria

- National Collection of Type Cultures (NCTC), Central Public Health Laboratory Service, Colindale Avenue, London NW9 5HT, UK.  
E-mail: nctc@phls.nhs.uk  
Website: www.phls.co.uk
- American Type Culture Collection (ATCC), 12301 Parklawn Drive, Rockville, MD 20852, USA  
E-mail: help@atcc.org  
Website: www.atcc.org
- Centers for Disease Control (CDC) Bacterial Diseases Division, Atlanta GA 30333, USA.
- Mast Diagnostics (see Appendix 11) supply QC sticks consisting of lyophilized gelatin pellets of microorganisms derived from ATCC or NCTC strains. They are sold, 3 QC sticks per pack. They have a 2 year shelf-life.
- Oxoid (see Appendix 11) supply quality control organisms (ATCC strains) on loops, i.e. *Culti-Loops* in packs of 5 loops (Remel) or packs of 100 loops (Oxoid).

### Control of nutrient agar, blood agar, chocolate agar

Use appropriate control species as listed in Chart 7.7. Inoculate slopes or quarter plates of the medium to be tested with a 5 hour broth culture of each control organism. Use a straight wire to inoculate the medium and a wire loop to spread the inoculum. Depending on the species, incubate aerobically or in a carbon dioxide enriched atmosphere at 35–37°C.

After overnight incubation, examine the cultures for the degree of growth, size of colonies, and other characteristics such as *alpha*- or *beta*-haemolysis. Record the results of each control species and compare with the results of previous performance tests.

### Control of a differential medium

Use control species that show the differential features of the medium as listed in Chart 7.7. Inoculate quarter plates of the medium to be tested with a 5 hour broth culture of each control species. Use a straight wire to inoculate the medium and a wire loop to spread the inoculum. Incubate aerobically at 35–37°C.

After overnight incubation, examine the cultures for the differential characteristics of the medium. Record the results of each control species and compare with the results of previous tests.

**Control of a selective medium**

Use the control species that show the selectivity and inhibitory properties of the medium as listed in Chart 7.7.

**Technique of testing a selective medium**

- 1 Prepare a 5 h broth culture of the organism to be selected and a 5 h mixed broth culture of the organism(s) to be inhibited.
- 2 Take three sterile tubes and label 1 to 3. Using a sterile Pasteur pipette, place in each tube, 5 drops of the broth culture containing the organism to be selected.
- 3 Using a second sterile Pasteur pipette, add to each tube the following drops of the mixed broth culture containing the organisms to be inhibited:
 

<i>Tube 1:</i>	5 drops
<i>Tube 2:</i>	10 drops
<i>Tube 3:</i>	15 drops
- 4 Divide a plate of the medium to be tested into three segments and label 1, 2, and 3. Using a small sterile loop, inoculate the appropriate segments of the plate with a loopful of the organism suspension from the tubes (i.e. 1 loopful from tube 1 in segment 1, etc).
- 5 Inoculate a second plate of the medium with a loopful of the pure 5 h broth culture of the organism to be selected.
- 6 After overnight incubation at 35–37°C, record the degree of selectivity of the medium (from the segmented plate) and the size and appearance of the colonies of the selected organism (from the pure culture plate). Compare with the results of previous performance tests.

**Control of a biochemical testing medium**

Most biochemical testing media are controlled at the time they are used. The medium is inoculated with bacterial species of known positive and negative reactions as explained in subunit 7.3.

**Control of a transport medium**

Immerse in the medium a swab of the specimen containing the pathogen(s) to be preserved (e.g. urogenital swab containing *N. gonorrhoeae* in Amies medium, or a faecal swab containing *Shigella* or *Salmonella* in Cary-Blair medium).

Leave the inoculated transport medium at room temperature (protected from direct light) for the length of time the medium is intended to preserve the viability of the pathogen(s) it contains. After this time, inoculate the swab on an appropriate medium to check for viability of the pathogen.

**Control species**

Chart 7.7 lists some of the microorganisms that are suitable for testing the performance of different culture media (see previous text for sources of control organisms). Also listed are media recommended for the maintenance of control cultures and the recommended frequency of subculturing.

Most species of bacteria required to control the culture media used in district laboratories, can be maintained in nutrient agar deeps covered with sterile mineral oil, in semisolid nutrient agar, on slopes of Dorset egg medium, or in cooked meat medium or Amies transport medium. Control species of anaerobes are best preserved in cooked meat medium.

**Long-term preservation of control strains**

This is possible by storing in 16% v/v glycerol broth at –20°C. Glycerol nutrient broth is prepared by mixing 16 ml of glycerol with 84 ml of nutrient broth, dispensing in 5 ml amounts in bottles, and autoclaving at 115°C for 20 minutes. Prepare the control organisms on blood agar. Using a sterile swab, subculture the entire growth of an overnight pure culture in 5 ml of sterile 16% v/v glycerol broth, and freeze immediately.

After 24 hours, check the viability of the organism by thawing the suspension at 35–37°C, and inoculating it on a plate of blood agar. If satisfactory growth occurs, re-freeze the suspension and store at –20°C or below. Some bacterial species can be maintained for several years by this method. Record the colonial, biochemical, and other characteristics of each control strain both before and after storage.

*Note:* In reference laboratories, control strains of bacteria are usually stored in lyophilized form. This ensures stability and viability of bacterial strains for many years.

To reduce the risk of contamination and changes in the growth characteristics of control strains, stock cultures should not be subcultured more than is necessary. Several subcultures should be prepared at one time. Guidelines for the frequency of subculturing of the different control species is given in Chart 7.7.

**Labelling and storage of culture media and additives**

As previously discussed, dehydrated culture media and dry ingredients such as peptone, tryptone, and carbohydrates (solid form) should be stored at an even temperature in a cool dry place away from direct light. Container tops must be tight-fitting and in humid climates, tape-sealed.

Additives such as blood, serum, antimicrobials in solid form, urea and carbohydrate solutions, require storage at 2–8°C. All additives should be allowed to warm to room temperature before being used. Antimicrobial solutions should be stored frozen at –20°C in the amounts required.

Plates of culture media should be stored at 2–8°C, preferably in sealed plastic bags. Most media in screw-cap tubes or bottles can be stored at room temperature (20–28°C). Prepared media should be stored in the dark. When in use, the media must be protected from direct light, especially sunlight.

Chart 7.7 Quality control of commonly used culture media

<i>Culture medium</i>	<i>Recommended Control species</i>	<i>Maintenance medium</i>	<i>Subculturing interval</i>
<b>Alkaline peptone water</b>	Enriched: <i>Vibrio</i> species (Use small inoculum)	Nutrient agar semisolid or deep	6 months
	Inhibited controls: <i>Escherichia coli</i> <i>Proteus</i> species	As above	As above
<b>Blood agar</b>	<i>Streptococcus pyogenes</i> <i>Streptococcus pneumoniae</i>	Cooked meat medium	3 months
	<i>Haemophilus influenzae</i> (With <i>S. aureus</i> streak)	Chocolate agar slope (35–37°C)	1 month
<b>Chocolate agar</b>	<i>Haemophilus influenzae</i>	Chocolate agar slope (35–37°C)	1 month
<b>Cooked meat medium</b>	<i>Clostridium sporogenes</i>	Cooked meat medium	12 months
<b>Cystine lactose electrolyte deficient agar (CLED)</b>	<i>Staphylococcus aureus</i> <i>Proteus mirabilis</i>	Nutrient agar semisolid or deep	6 months
<b>Kligler iron agar (KIA) or Triple sugar iron agar</b>	<i>Citrobacter freundii</i> <i>Proteus vulgaris</i> <i>Alcaligenes faecalis</i>	Nutrient agar	6 months
<b>MacConkey agar</b>	<i>Escherichia coli</i> <i>Proteus mirabilis</i>	Nutrient agar semisolid or deep	6 months
<b>Modified New York City (MNYC) medium or other selective medium to isolate <i>N. gonorrhoeae</i></b>	Selected: <i>Neisseria gonorrhoeae</i>	Amies medium (Use heavy inoculum and store at 2–8°C)	2 weeks
	Inhibited control: <i>Proteus vulgaris</i>	Nutrient agar semisolid or deep	6 months
<b>Thioglycollate broth</b>	<i>Clostridium</i> species or <i>Bacteroides</i> species	Cooked meat medium	12 months
<b>Thiosulphate citrate bile salt sucrose (TCBS) agar</b>	Selected: <i>Vibrio cholerae</i> (Nonpathogenic strain NCTC 11218)	Nutrient agar semisolid or deep	6 months
	Inhibited control: <i>Escherichia coli</i>	As above	As above
<b>Columbia agar diphasic medium</b>	<i>Streptococcus pyogenes</i> <i>Staphylococcus aureus</i>	Cooked meat medium	3 months
	<i>Haemophilus influenzae</i>	Chocolate agar slope (35–37°C)	1 month
<b>Xylose lysine deoxycholate (XLD) agar</b>	<i>Salmonella</i> Typhimurium	Dorset egg medium	12 months
	<i>Escherichia coli</i>	Nutrient agar semisolid or deep	6 months

*Notes*

- Use well-characterized stable strains of control organisms (for sources, see previous text).
- When subculturing from solid control cultures, take growth from several colonies. Prepare several subcultures (up to 6 for enterobacteria).
- Do not attempt to use a control culture that has become contaminated.
- Label clearly control cultures with the name of the species (and strain if known) and date of inoculation.
- Store control cultures in a *secure* place away from light. Most controls can be stored at room temperature (20–28°C).
- Make sure the bottle tops of control cultures are screwed tightly.
- The preparation of nutrient agar deeps, semisolid nutrient agar, Dorset egg medium, and cooked meat medium are described in Appendix 1.

All culture media and additives must be clearly labelled. When colour codes are used, an identification chart should be prepared and displayed. Each batch of prepared medium should be given a number and the date of its preparation recorded.

### Sterilizing glass petri dishes, tubes and other glassware in a hot air oven

To sterilize glassware by dry heat, a temperature of 160 °C held for 45–60 minutes is required, *timed from when the items in the oven have reached this temperature*. A heating up time (of up to 1 hour) must therefore be allowed. A cooling time is also necessary to enable the items in the oven to cool slowly. The oven door must *not* be opened until the temperature inside the oven has fallen to above 50 °C. This will avoid cracking the glassware and air, which may contain contaminating organisms, being drawn into the oven.

For the needs of most district microbiological laboratories, a small capacity hot air oven of the convection type is adequate. To enable maintenance and any repairs to be carried out locally, an oven fitted with a simple hydraulic thermostat and analogue (dial) thermometer is recommended in preference to a microprocessor controlled oven. The oven must be fitted with a protective over-heat cut out device. The more expensive microprocessor controlled ovens are usually fitted with a fan, temperature chart recorder, port for thermocouples, and a door interlock.

**Availability:** An example of a convection type hot air oven fitted with an hydraulic thermostat, external thermometer and safety cut-out, is the model E28, manufactured by Binder (see Appendix 11). It is shown in Plate 7.3. Internally the oven measures 400 mm wide × 250 mm deep × 280 mm high (external dimensions: 580 × 425 × 402 mm high). Its power consumption is about 800 W and it weighs 18 Kg. It has a temperature range of 60–230 °C, with an accuracy of  $\pm 1.5$  °C and variation of  $\pm 3$  °C. A pilot light shows when the oven is switched on.

Items suitable for sterilizing in a hot air oven (at 160 °C) include:

- glass or aluminium petri dishes (not plastic dishes).
- glass tubes (rimless) fitted with aluminium caps or with non-absorbent cotton wool plugs.
- bottles with aluminium caps lined with silicone rubber (not red or black rubber). Autoclaving is also suitable for bottles.
- glass flasks and cylinders (cover the open end with aluminium foil or paper, tied on with string).
- glass pipettes (graduated and Pasteur) with ends

plugged to a depth of about 20 mm with *non-absorbent* cotton wool.

- nylon or glass syringes (not polypropylene or other plastic).
- metal needles, lancets, and forceps (not plastic).
- dry swabs in tubes, plugged with non-absorbent cotton wool.

Items for dry heat sterilizing must be dry. They can be wrapped individually in brown (*Kraft*) paper (X-ray film wrapping paper can also be used and reused) or placed in aluminium or copper canisters, e.g. petri dishes and pipettes. *Do not* overload the oven. When not used as a sterilizing oven, a hot air oven can also be used at a *lower temperature* (80–100 °C) to dry routine glassware. Follow carefully the manufacturer's instructions on how to use and maintain the oven.



Plate 7.3 WTB Binder E 28 model, 60–230 °C hot air oven with external thermometer and timer and fitted with thermostat and overheat cut-out. *Courtesy of WTB Binder.*

### HOW TO DISPENSE CULTURE MEDIA

Media should be dispensed in a clean draught-free room. Most fluid media are dispensed into screw-capped bottles or tubes, and then sterilized by autoclaving. Sterile media must be dispensed into sterile petri dishes, tubes or bottles using an aseptic technique.

#### Dispensing sterile media into petri dishes

- 1 Lay out the sterile petri dishes on a level surface.
- 2 Mix the medium gently by rotating the flask or bottle. Avoid forming air bubbles. Flame sterilize the neck of the flask or bottle and pour 15–20 ml of medium into each dish (90–100 mm diameter).

If air bubbles enter while pouring, rapidly flame the surface of the medium before gelling occurs. Rotate the dish on the surface of the bench to ensure an even layer of agar.

- 3 When the medium has gelled and cooled, stack the plates and seal them in plastic bags to prevent loss of moisture and reduce the risk of contamination. Do not leave the plates exposed to bright light especially sunlight.
- 4 Store at 2–8 °C.

*Note:* Agar plates should be of an even depth (not less than 4 mm) and of a firm gel. The surface of the medium should be smooth and free from bubbles.

### Dispensing and solidifying high protein media (inspissation)

High protein media such as Dorset egg medium and Loeffler serum medium are dispensed aseptically in screw-capped bottles and solidified in a sloped position at a controlled temperature (75–80 °C) for 1–2 hours. Solidification of protein media using heat to coagulate the protein, is called inspissation.

Inspissation can be carried out in an inspissator (water-jacketed container which allows water vapour to enter the inspissating area), or in a 75–80 °C thermostatically controlled water bath or oven (over a tray of water to prevent drying of the medium). The bottle tops should be left loose during inspissation (tighten them later).

To prevent bubbles forming in the medium, the temperature should be raised slowly and 80 °C must not be exceeded.

### HOW TO INOCULATE CULTURE MEDIA

Immediately before inoculating a culture medium, check the medium for visual contamination or any change in its appearance which may indicate deterioration of the medium, e.g. darkening in colour.

When inoculating, or seeding, culture media an aseptic (sterile) technique must be used. This will:

- prevent contamination of cultures and specimens,
- prevent infection of the laboratory worker and the environment.

### Aseptic techniques

- Flame sterilize wire loops, straight wires, and metal forceps before and after use (see Fig. 7.3). Whenever possible, use a Bunsen burner with a

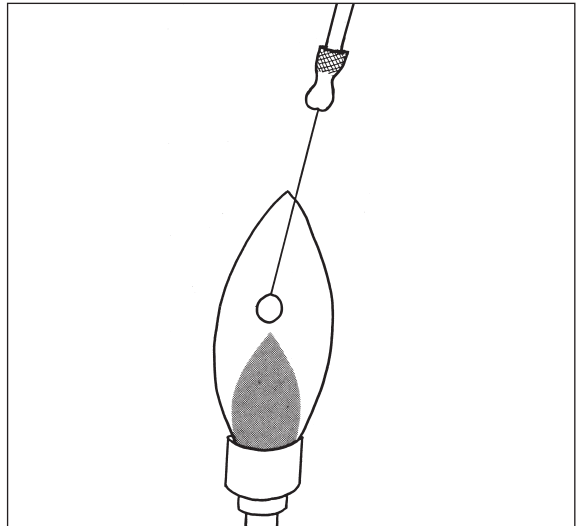

Fig 7.3 Sterilizing a wire loop in the flame of a Bunsen burner.

protective tube, e.g. *Bactiburner* to avoid particles being dispersed when flame sterilizing wire loops (see p. 62 and p. 170 in Part 1 of the book).

*Note:* To prevent the release of aerosols, wire loops must be well made (see later text). Aerosols can also be released when spreading inocula on media containing air bubbles.

- Flame the necks of specimen bottles, culture bottles, and tubes after removing and before replacing caps, bungs, or plugs.
- When inoculating, do not let the tops or caps of bottles and tubes touch an unsterile surface. This can be avoided by holding the top or cap in the hand as shown in Fig. 7.4.

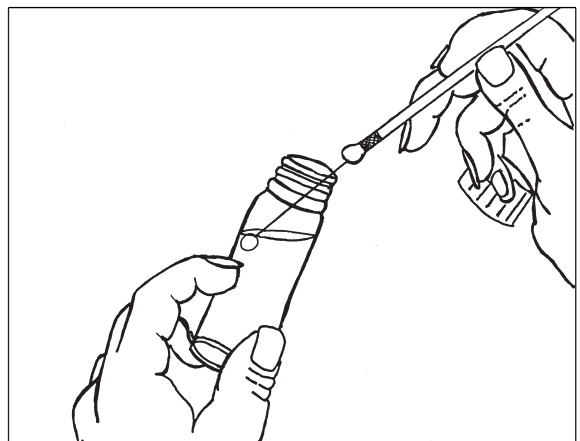

Fig 7.4 Inoculating a bottle of sterile medium. The neck of the bottle is flamed before and after inoculating the medium. The cap of the bottle is held in the hand as shown.

- Always use racks to hold tubes and bottles containing specimens or culture media.
- Make slide preparations from specimens after inoculating the culture media.
- Decontaminate the work bench before starting the day's work and after finishing.  
*Note:* Decontamination of infected material is described in Part 1 of the book (see subunit 3.4).
- Use a safety cabinet when working with hazardous pathogens (see pp. 64–65 in Part 1).
- Wear protective clothing, wash the hands after handling infected material, and never mouth-pipette, eat, drink, or smoke in the laboratory (see also subunit 3.4 in Part 1).

### Making a wire loop

Loops must be made correctly to ensure inocula are well spread, and to prevent the release of aerosols from long and springy loops or loops that are not completely closed. The length of wire from the loop to the loop holder should be short (6 cm) and the loop itself should be small (2 mm diameter) and fully closed.

Reusable loops are usually made of nichrome (nickel-chromium) wire because it cools quickly, is not too rigid, and is less expensive than platinum wire. The thickness of the wire should be of standard wire gauge (swg) 26 or 27. Disposable plastic loops are widely available but more expensive to use than wire loops.

### Purchasing ready-made wire loops

Order nickel-chromium wire loop of 2 mm diameter (holding 1/500 ml) and no longer than 60 mm in length. Order as a complete loop with handle. Alternatively purchase the ready-made wire loops and wire loop holder with screw-head chuck. Suppliers include Developing Health Technology (see Appendix 11). If unable to purchase ready-made, make a loop as described in the following method.

### Method of making a wire loop to fit in a screw-head chuck wire holder

- 1 Cut a piece of wire about 125 mm in length (swg 26 or 27). Wind it around a loop holder as shown in Fig. 7.5.
- 2 Using a pair of scissors, cut off one arm of the wire leaving the loop and about 50 mm of wire. Bend the loop back to make it central using a pair of forceps.
- 3 Insert the wire in a loop holder as shown in Fig. 7.5. Make sure the loop is completely closed.

*Note:* When sterilizing a wire loop, hold it in the blue part of a Bunsen burner flame (see Fig. 7.3). When

the laboratory does not have a piped gas supply, use a portable burner such as a *Labogaz* burner. Allow the loop to cool before using it.

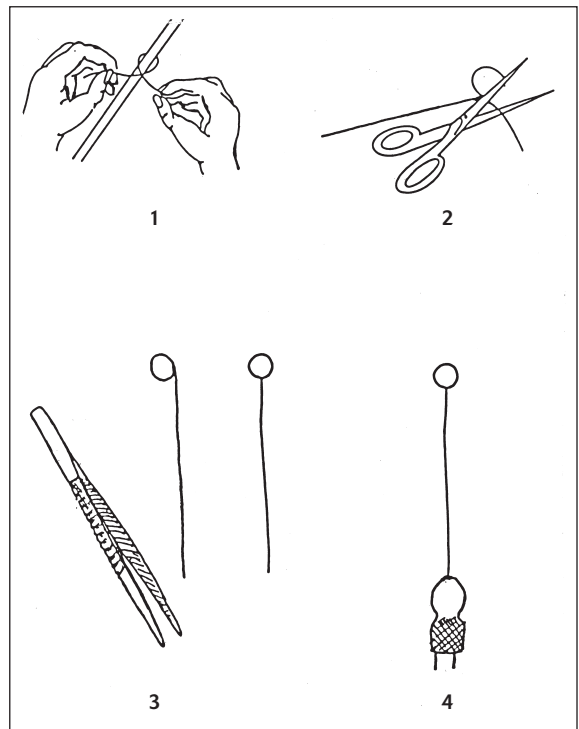

Fig 7.5 How to make a wire loop (see text for method).

### Inoculation of media in petri dishes

The technique used to inoculate media in petri dishes (plates) must provide single colonies for identification. It must also show whether a culture is pure or mixed, i.e. consisting of a single type of organism or several different organisms. A pathogen must be isolated in pure culture before it can be identified and tested for antimicrobial sensitivity.

The inoculation of media in petri dishes is referred to as 'plating out' or 'looping out'. It is not necessary to use whole plates of media for every specimen. Considerable savings can be made by using a half or even a third of a plate (especially when the medium is a selective one). The area of medium used must be sufficient to give separate colonies.

Before inoculating a plate of culture medium, the surface of the medium must be dried, otherwise single colonies will not be formed. To do this, remove the lid of the plate and place this face upwards on an incubator shelf. Invert the base con-

taining the medium and let it rest at an angle on the lid. Usually 30–40 minutes incubation at 35–37 °C is sufficient time to dry the surface of an agar plate.

#### *Inoculating technique*

- 1 Using a sterile loop or swab of the specimen, apply the inoculum to a small area of the plate (the 'well') as shown in Fig. 7.6.
- 2 Flame sterilize the loop. When cool, or using a second sterile loop, spread the inoculum as shown in Fig. 7.6 (follow the steps 2 through to 5). This will ensure single colony growth.

*Note:* A simplified technique of inoculating plates is shown in Fig. 7.7. This can be used by medical and nursing staff when culturing specimens directly from patients, e.g. urogenital specimens for the isolation of *Neisseria gonorrhoeae*. The techniques of inoculating half a plate and a third of a plate of medium are shown in Fig. 7.8 and Fig. 7.9.

#### **Inoculation of slopes**

To inoculate slopes such as Dorset egg medium or Loeffler serum, use a sterile straight wire to streak the inoculum down the centre of the slope and then spread the inoculum in a zig-zag pattern as shown in Fig. 7.10.

To inoculate a slope and butt medium, such as Kligler iron agar, use a sterile straight wire to stab into the butt first and then use the same wire to streak the slope in a zig-zag pattern (see Fig. 7.11).

#### **Inoculation of stab media (deeps)**

Use a sterile straight wire to inoculate a stab medium. Stab through the centre of the medium as shown in Fig. 7.12, taking care to withdraw the wire along the line of inoculum without making further stab lines.

#### **Inoculation of fluid media**

Broths and other fluid media are inoculated using a sterile wire loop, straight wire, or Pasteur pipette depending on whether the inoculum is a colony, a fluid culture, or a specimen. The inoculation of blood culture broths is described in subunit 7.14.

When using a wire loop to subculture colonies, hold the bottle or tube at an angle and rub the loop against the side of the container below the level of the fluid.

When using a Pasteur pipette to inoculate a fluid culture hold the pipette as shown in Fig. 7.13 (box). How to make Pasteur pipettes in the laboratory is shown in Fig. 7.13.

#### **Labelling of inoculated media**

Using a grease pencil or marker pen, label inoculated media with the date and the patient's number. Always label the base of a culture plate, not the lid (lids can be accidentally switched).

Label a slope on the underside of the medium so that the wording does not obscure the culture. A stab culture should be labelled above the level of the agar.

When a plate is to be incubated anaerobically it should be marked 'An O<sub>2</sub>' or when in a carbon dioxide atmosphere it should be marked 'CO<sub>2</sub>'.

#### **INCUBATION OF INOCULATED MEDIA**

Inoculated media should be incubated as soon as possible. A delay in incubation can affect the viability of pathogens especially anaerobes, pneumococci, meningococci, gonococci, and *Haemophilus influenzae*. It can also increase the risk of plates becoming contaminated from small insects and dust. Uninoculated and inoculated media must be protected from sunlight.

Microorganisms require incubation at the temperature and in the humidity and gaseous atmosphere most suited to their metabolism. The length of time of incubation depends on how long an organism takes to develop the cultural characteristics by which it is recognized.

#### **Temperature of incubation**

The temperature at which a microorganism grows best is referred to as its optimum temperature. The temperature below which growth stops (not necessarily resulting in death) is called the minimum temperature, and that above which growth stops and death occurs is called the maximum temperature.

The temperature selected for routine culturing is 35–37 °C with most microbiologists recommending 35 °C in preference to 36 °C or 37 °C. In general, the growth of microorganisms is more affected by slight rises above their optimum temperature than by reductions below it.

#### **Incubators for use in district laboratories**

The specifications of an electric incubator for use in district microbiological laboratories can be found in subunit 4.9 in Part 1 of the book. A small, low cost, mains and battery operated incubator is also described for those laboratories incubating only a few cultures. Subunit 4.9 also includes guidelines on the use and care of incubators.

In tropical countries it is possible to grow some pathogens at local room temperatures, e.g. *Vibrio*



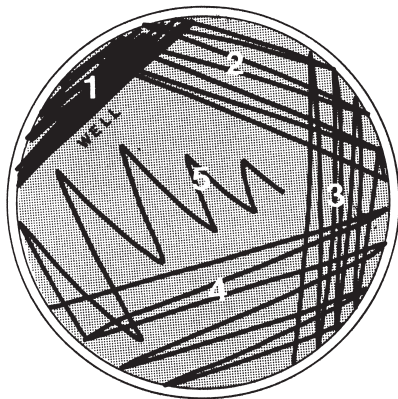

Fig 7.6 Inoculation of a plate of culture medium to give single colonies

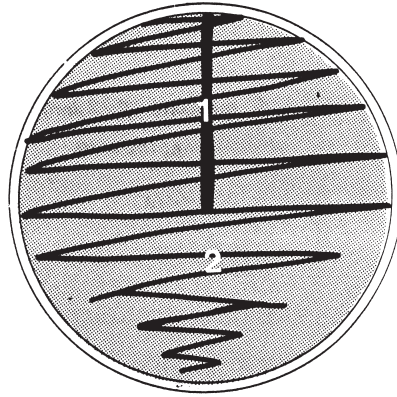

Fig 7.7 Simplified technique of inoculating a plate of culture medium, suitable for use in clinics

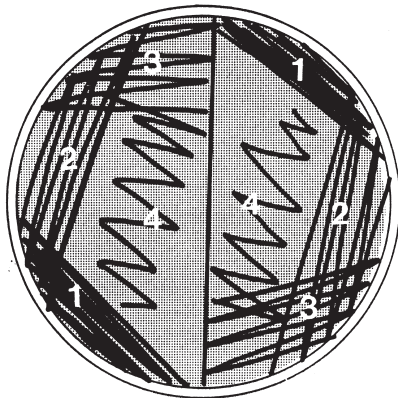

Fig 7.8 Inoculation of half a plate of culture medium

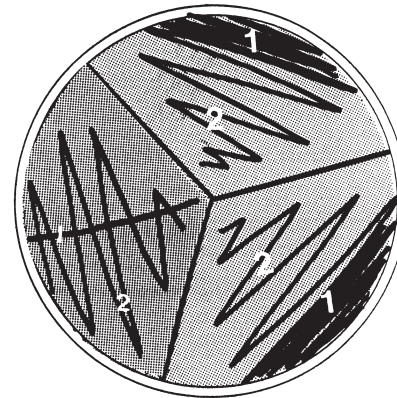

Fig 7.9 Different ways of inoculating a third of a plate of culture medium

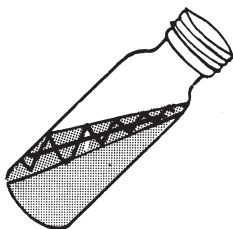

Fig 7.10 Inoculation of an agar slope

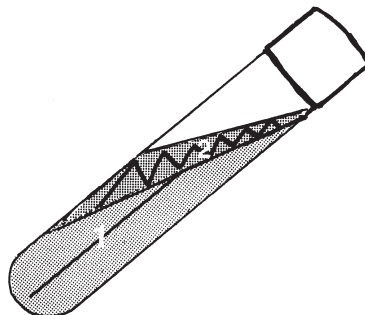

Fig 7.11 Inoculation of a butt and slope. Use a straight line to inoculate the butt first

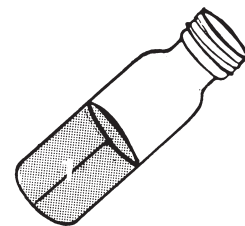
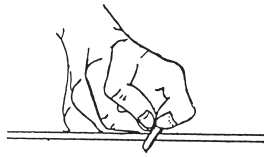
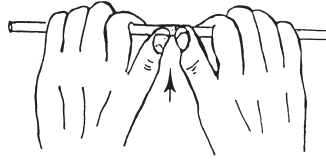

Fig 7.12 Inoculation of a deep (stab)



1 Etch the glass tubing in 16 cm lengths.



2 With the etch uppermost, break the tubing.

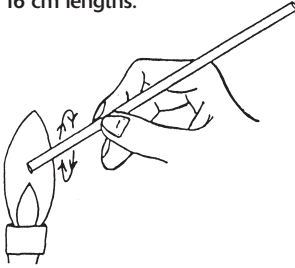

3 Round off the ends of each rod in the flame. When cool, wash and dry.

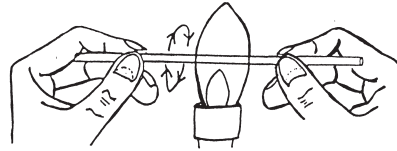

4 Heat the centre of the rod, turning it continuously in the hottest part of the flame.

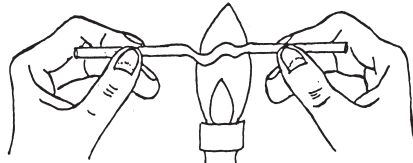

5 Continue heating until the glass becomes molten.

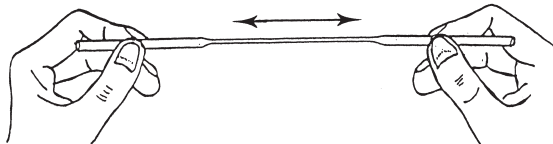

6 Remove from the flame and pull slowly and steadily. Pull more quickly if a thin stemmed pipette is required.

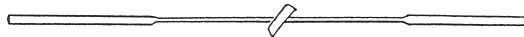

7 Etch the centre, and break to give two Pasteur pipettes.

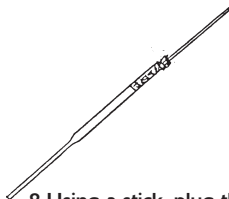

8 Using a stick, plug the ends of the pipettes with non-absorbent cotton wool. Place in a metal canister and sterilize in an oven or autoclave.

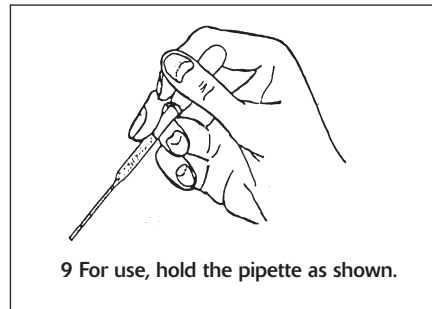

9 For use, hold the pipette as shown.

Fig 7.13 How to make a Pasteur pipette

Note: the glass tubing should be 0.8–0.9 mm thick and have an external diameter of 6–7 mm.

*cholerae*. Growth, however, tends to be slower and variations in temperature can affect growth. When not using an incubator, cultures must be protected from sunlight, contamination, and drying by being placed in a container in the dark.

*Yersinia enterocolitica* grows best at 20–28 °C which helps to identify the species. Temperature of growth is also used in the differentiation of *Mycobacterium* species, e.g. no growth is produced by *M. tuberculosis* and *M. ulcerans* at 25 °C whereas many opportunistic and saprophytic mycobacteria grow at this lower temperature.

### Humidity

An atmosphere which is too dry can affect the growth and viability of many pathogens, e.g. gonococci are rapidly killed in dry conditions. Inclusion of a piece of damp blotting paper in the bottom of a candle jar, is therefore recommended for the culture of gonococci.

### Gaseous atmosphere

Microorganisms vary in their need for oxygen and use of it as a means of producing energy. Depending on its atmospheric requirements, an organism can be described as:

- *An obligatory (strict) aerobe*: Requires free oxygen to survive. An example of an obligatory aerobe is *Pseudomonas aeruginosa*.
- *A microaerophilic organism*: Grows best in the presence of only a trace of free oxygen. An example of a microaerophilic organism is *Campylobacter jejuni*.
- *An obligatory (strict) anaerobe*: Survives only in the absence of oxygen. An example of an obligatory anaerobe is *Clostridium tetani*.
- *A facultative anaerobe*: Can live with or without free oxygen. Examples of facultative anaerobes are *Staphylococcus aureus*, *Streptococcus pyogenes*, *Escherichia coli*.
- *A carboxyphilic organism*: Requires an atmosphere which contains carbon dioxide. An example of a carboxyphilic organism is *Neisseria meningitidis*. Traces of carbon dioxide (5–10%), however, are thought to help the growth of most bacteria.

### Culturing of anaerobes

An anaerobic atmosphere is essential for the growth of strict anaerobes such as *Clostridium* species, *Bacteroides* species, and anaerobic streptococci.

Anaerobic incubation also helps to differentiate pathogens and to isolate facultative anaerobes from

specimens containing commensals, e.g. *Streptococcus pyogenes* from throat swabs. The haemolytic reactions of *beta*-haemolytic streptococci are also more pronounced following anaerobic incubation.

There are several techniques for obtaining anaerobic conditions. Those which are more suited for district microbiology laboratories include the use of:

- Commercially produced sachets containing oxygen removing chemicals. These recently developed safe technologies do not produce hydrogen and therefore do not require a catalyst, i.e. they are non-gas generating systems.
- Copper coated steel wool to remove oxygen.
- Reducing agents in culture media.

### Commercially produced oxygen-removing systems

Examples of systems that produce anaerobic conditions by using chemicals that absorb oxygen are the *Anaerocult* system produced by Merck/BDH and the *AneroGen* system produced by Oxoid (see Appendix 11). Whereas the oxygen-removing sachets produced by Oxoid can only be used in anaerobic jars, Merck produces a range of sachets that can be used to incubate a single culture plate (in a sealed plastic bag), up to four plates, and plates in anaerobic jars.

#### Merck Anaerocult anaerobic system

The sachets contain a mixture of iron powder, citric acid, sodium carbonate, and kieselguhr. Addition of a small volume of water activates the chemicals. Oxygen is rapidly removed leaving anaerobic conditions. Some carbon dioxide is produced. The following sachets are available:

- *Anaerocult P* (order No. 1.13807.0001) for the anaerobic incubation of one petri dish. Each pack contains 25 sachets and 25 foil bags (petri dish with sachet is placed inside a foil bag). No anaerobic jar is needed. Reusable clips (*Anaeroclips*) to seal the bags are required. These are available in packs of 25 (order No. 1.14226.0001).
- *Anaerocult A mini* (order No. 1.01611.0001) for the anaerobic incubation of up to 4 petri dishes. Each pack contains 25 sachets and 25 foil bags (anaerobic jar is not needed). As for *Anaerocult P*, sealing clips are required (see above text).
- *Anaerocult A* (order No. 1.13829.0001), for use in 2.5 litre capacity anaerobic jars. Each pack contains 10 sachets. No clips are needed.

**Control of Anaerocult system:** Use of the anaerobic indicator strip, *Anaerotest* is recommended. Each pack contains 50 strips.

#### Oxoid AneroGen system

The active oxygen-removing component in *AneroGen* sachets is ascorbic acid. The sachets are designed for use in 2.5 litre and 3.5 litre capacity anaerobic jars. The paper sachet is

placed in the jar immediately before it is closed. No water is needed to activate the chemical. Within 30 minutes of closing the jar, the oxygen level is reduced to below 1% (carbon dioxide level is 9–13%).

Two types of *AneroGen* sachet are available:

- AN 3.5 sachets (order No. ANO35A) for use with 3.5 litre anaerobic jars. Each pack contains 10 sachets.
- AN 2.5 sachets (order No. CN025A) for use with 2.5 litre jars. Each pack contains 10 sachets.

#### Control of the *AneroGen* system

Use of an anaerobic control indicator (resazurin) in the jar is recommended (order No. BRO55B) to ensure anaerobic conditions have been produced).

#### Use of copper coated steel wool to remove oxygen

This is a simple method of obtaining anaerobiosis when it is not possible to obtain the commercially produced oxygen-removing sachets. It can be adapted for incubating single plates or several plates. The plates can be incubated in a plastic bag providing it is airtight. The system uses steel wool which is activated immediately before use by being dipped in acidified copper sulphate solution. The metallic copper on the surface of the iron rapidly absorbs oxygen. Anaerobic conditions are obtained more rapidly by removing some of the air from the bag before it is sealed. A source of carbon dioxide is added and also an indicator to check for anaerobiosis. The method of use is as follows:

- 1 Place the inoculated plates in an undamaged strong plastic bag no larger than the size required. Support the bag on a tray or other rigid sheet.
- 2 Place in the bag an open tube or bottle containing equal volumes of magnesium carbonate and sodium bicarbonate for the release of carbon dioxide. About 1.5 g of each chemical is required for a bag measuring about 250 × 180 mm. The chemicals can be pre-mixed and stored dry in screw-cap bottles ready for use. Alternatively use half an *Alka-Seltzer* tablet.
- 3 Prepare the steel wool as follows:
  - Take a loose pad of about 3–5 g of steel wool (grade 0 or 1). This is sufficient for a bag measuring about 250 × 180 mm.
  - Dip the steel wool for a few seconds in acidified copper sulphate solution (see below) until the wool appears dark grey with no more than a trace of copper colour. Drain, and place in an open dish.

*Note:* Some batches of steel wool are greasy and resist coating with the copper (i.e. do not become dark grey). If this happens, wash the steel wool in detergent, rinse well, and shake to remove the water. When degreased, the steel wool will rapidly become copper coated.

#### Preparation of the acidified copper sulphate solution

The solution requires renewing every week.

Prepare by mixing:

Copper sulphate, 10% w/v solution	5 ml
Tween 80 (or Lissapol), 10% w/v	5 ml
Sulphuric acid, 2 mol/l*	3 ml
Distilled water	to 200 ml

\*Prepare by adding 11 ml of concentrated acid to 89 ml of water.

*Caution:* NEVER add the water to the acid because sulphuric acid is hygroscopic. Handle the acid with great care because it is highly corrosive.

- 4 Add 5 ml of water to the magnesium carbonate and sodium bicarbonate. When using an *Alka-Seltzer* tablet, moisten the tablet with a few drops of water. Carbon dioxide will be slowly released.
- 5 Enclose an anaerobic strip indicator in the anaerobic bag to check for anaerobiosis (buy commercially from Oxoid or Merck as described previously).
 

*Note:* Complete anaerobic conditions are usually obtained within 4 hours of sealing the bag.
- 6 Just before sealing the anaerobic bag, use a piece of rubber tubing and syringe to draw out some of the air.
- 7 Seal the bag with Sellotape or other reliable adhesive tape, and incubate the bag on its tray at 35–37°C. Providing a transparent bag has been used, the cultures can be viewed for growth without needing to open the bag.

#### Use of reducing agents in culture media

Examples of media that contain reducing agents include:

- Thioglycollate broth which is used mainly to culture anaerobes in blood (see subunit 7.14). The medium contains the reducing agent sodium thioglycollate and the indicator methylene blue or resazurin to show that the medium is reduced. Preparation of the medium is described in Appendix 1.
- Cooked meat medium which is used to culture *Clostridium* and *Bacteroides* species. The anaerobes grow at the bottom of the medium among the meat particles which contain effective reducing

substances. The medium shows saccharolytic and proteolytic reactions and also gas production. Its preparation is described in Appendix 1.

A simple way of providing anaerobic conditions in litmus milk medium, peptone water media, and broths is by using an iron strip (25 × 3 mm sheet iron) or an iron nail to remove the oxygen. The strip or nail is flame sterilized and while still hot it is dropped into the medium. When the medium has cooled, it can be inoculated.

### Anaerobic container

With the availability of oxygen-removing systems to produce anaerobic conditions, an anaerobic jar with pressure gauge, valves, etc is no longer needed. An acrylic air-tight container such as that supplied by BD Diagnostics (see Appendix 11) and shown in Plate 7.4 is suitable.

#### Availability

Two sizes of container are available from BD Diagnostics:

- 15 plate container, code 260671
- 30 plate container, code 260672

Each container has a lid with easy to close latches which give a secure airtight seal. A removeable rack is available for holding culture plates. To obtain anaerobic conditions inside the container, a BD *GasPak* EZ anaerobic container sachet code 260678, is used. To obtain a carbon dioxide enriched atmosphere, a *GasPak* EZ sachet code 260679 is needed. A *Campylobacter* container sachet is also available, code 260680. An anaerobic indicator is required when incubating anaerobically, code 271051.



Plate 7.4 Left: BD *GasPak* container system. Right: BD *GasPak* pouch system.  
Courtesy BD Diagnostics.

### BD pouch systems

BD Diagnostics also supply a pouch system for incubating anaerobically up to 2 culture plates (see Plate 7.4) or up to 4 culture plates. Each resealable pouch is supplied with a gas-generating sachet and anaerobic indicator strip. Pouches are also available for providing a CO<sub>2</sub> enriched atmosphere and conditions for incubating *Campylobacter*.



Plate 7.5 Systems for culturing in carbon dioxide. The jar can be used with chemicals which provide a carbon dioxide (CO<sub>2</sub>) enriched atmosphere and the tin with a candle to provide CO<sub>2</sub> conditions (see text). Reproduced from *Laboratory diagnosis of sexually transmitted diseases*, WHO 1999, with the permission of the World Health Organization.

### Culturing in carbon dioxide

A carbon dioxide enriched atmosphere is required for the growth of *Neisseria gonorrhoeae*, *Neisseria meningitidis*, *Brucella* species, and *Streptococcus pneumoniae*. Commercially available carbon dioxide gas-generating systems are available (see previous text). When such a system is not available, a simple way of providing a carbon dioxide enriched atmosphere is to enclose the inoculated plates (inverted) in an airtight jar or tin with a lighted candle.\* As the candle burns, the oxygen content is reduced leaving a carbon dioxide content of 3–5% by the time the candle is extinguished. The screw-cap jar or tin should not be more than half filled. For the culture of *Neisseria* organisms, place a piece of damp filter paper or blotting paper in the bottom of the container to provide a moist atmosphere.

\**Important:* It is necessary to use a white wax smokeless candle or *nite-light* to avoid the release of fumes which may be bactericidal or interfere with the growth of bacteria. When it is not possible to obtain a good quality candle, carbon dioxide can be generated chemically in a jar or tin by reacting sodium

bicarbonate with tartaric acid or citric acid (see below).

#### Generation of carbon dioxide from chemicals

To obtain a 10% carbon dioxide atmosphere in a jar of about 3 litre capacity, mix 0.7 g sodium bicarbonate with 1.7 g tartaric acid (or 2.4 g citric acid). Immediately before closing the jar, moisten the chemicals with water. Alternatively, use an *Alka-Seltzer* tablet (moistened with a few drops of water).

*Note:* The above described chemical method of providing a carbon dioxide enriched atmosphere is *not* suitable for the culture of campylobacters. For the growth of these microaerophilic organisms a candle jar is required or the use of special commercially produced sachets such as those manufactured by BD Diagnostics (see previous text).

### REPORTING CULTURES

The manner of reporting cultures depends on whether the specimen has been taken from a site which is normally sterile or from a site with a normal microbial flora.

**Sites normally sterile:** Identify and report all bacteria isolated as far as their genera, and if helpful, identify the actual species. Specimens received from sterile sites include blood, bone marrow, cerebrospinal fluid, pleural and peritoneal fluids, and urine.

*Note:* Urine is regarded as being collected from a site which is sterile (the urinary tract), even though the urethra is not sterile and a mid-stream specimen may become contaminated with organisms as it is being passed.

When isolating organisms from sites that are normally sterile, it is necessary to use culture media which will support the growth of a wide range of organisms and often an enriched medium (see beginning of this subunit).

**Sites having a microbial flora:** Interpretation of cultures is more difficult and requires a knowledge of the patient's clinical condition to judge whether an isolate of a pathogen is the cause of a patient's illness. The laboratory report should indicate those organisms for which isolation techniques have been performed. For example, when no pathogens have been isolated from a faecal specimen cultured on a selective medium, the report should state 'No *Salmonella*, *Shigella* or cholera organisms isolated', not 'No pathogen isolated' or 'Normal bacterial flora only'.

Specimens received from sites having a normal bacterial flora include faeces, sputum, skin, throat, and

nose swabs, vaginal, cervical, and urethral swabs. When attempting to isolate organisms from specimens collected from sites having a normal microbial flora, it is quicker, more economical, and cultures are easier to read when selective media are used.

It is not helpful in a report to list all the normal flora bacteria that have been isolated. It can also be confusing to report isolates semiquantitatively, e.g. 'heavy growth of ...'. The number of organisms that grow is affected by many variables, including the culture medium used, conditions under which a specimen is kept, and length of time before a specimen is cultured. It is best simply to state that a particular pathogen has been isolated.

#### Preliminary reports

Although the full procedure for identifying an organism must be carried through, it can be useful in some situations to issue a preliminary report, e.g. a Gram report of a cerebrospinal fluid, or a wet preparation containing organisms suggestive of *V. cholerae*. Such preliminary reporting can help a medical officer in the treatment of a patient or the need to introduce isolation and control measures when a highly infectious pathogen is indicated.

## 7.5 Biochemical tests to identify bacteria

While several commercial systems for identifying bacteria are available, these are often difficult to obtain or too expensive to use in developing countries. This subunit includes a range of conventional biochemical tests and tablet identification tests which most district laboratories will be able to perform. The following tests are described in this subunit:

Test	Purpose
■ <i>Beta</i> -glucuronidase	To identify <i>E. coli</i>
■ Bile solubility	To differentiate <i>S. pneumoniae</i> from other <i>alpha</i> -haemolytic streptococci
■ Catalase	To differentiate staphylococci from streptococci
■ Citrate utilization	To differentiate enterobacteria
■ Coagulase	To identify <i>S. aureus</i>

- DNA-ase To help identify *S. aureus*
- Indole To differentiate Gram negative rods, particularly *E. coli*
- Litmus milk decolorization To help identify *Enterococcus* and some clostridia
- Lysine decarboxylase To assist in the identification of salmonellae and shigellae
- Oxidase To help identify *Neisseria*, *Pasteurella*, *Vibrio*, *Pseudomonas*
- Urease To help identify *Proteus*, *Morganella*, *Y. enterocolitica*, *H. pylori*

#### Biochemical tests to screen for *Salmonella* and *Shigella* in faecal specimens

Kligler iron agar (KIA) and Rosco enzyme tests to screen for *Salmonella* and *Shigella* in faecal specimens are described in subunit 7.11.

#### Carbohydrate fermentation tests

Peptone water sugars and Rosco sugar fermentation tablets to identify bacteria by their fermentation reactions are described in subsequent subunits under specific organisms.

#### PYR test

The pyrrolidonyl aminopeptidase (PYR) test to identify *S. pyogenes* is described in subunit 7.18.2.

### Rosco diagnostic tablets for microbial identification

The diagnostic tablets (*Diatabs*) developed by Rosco Diagnostica are microbial identification tests in stable tablet form. Some tablets are double test tablets, i.e. a single tablet is used to test for two reactions, e.g. indole combined with *beta*-glucuronidase (PGUA). The tablets have a long shelf-life (2–4 y) and good stability in tropical climates. They are available in vials of 25 or 50 tablets. The Rosco identification tablets are more economical to use than most commercially produced diagnostic identification discs, strips, stick tests, and some conventional biochemical tests that use expensive dehydrated media. The following are some of the Rosco tablet tests described in this publication:

<i>L</i> -Arabinose	Indole
<i>Beta</i> -lactamase	Lysine decarboxylase (LDC)
<i>Beta</i> -galactosidase (ONPG)	Nitrate reduction
<i>Beta</i> -glucuronidase (PGUA)	Ornithine decarboxylase (ODC)

Carbohydrate tests	Oxidase
Citrate	Pyrrolidonyl aminopeptidase (PYR)
Aesculin hydrolysis	Urease
Factors X, V, X+V	Voges-Proskauer (VP)
Glutamyl aminopeptidase	
Hippurate hydrolysis	

The full range of Rosco identification tablets can be found in the 2005, 6th edition *Diagnostic tablets for bacterial identification*, available from Rosco Diagnostica (see Appendix 11).

The Rosco tablets are easy to use. For most tests a tablet is simply added to a saline suspension of the test organism in a small test tube and the test incubated at 35–37 °C. For many tests, reactions can be read the same day after a few hours incubation. Separate reagents are required to read the reactions of some tests (supplied by Rosco).

*Note:* Rosco Diagnostica also produces low cost, stable (3–4 year shelf-life at room temperature), antimicrobial susceptibility testing tablets. These are described in subunit 7.16.

## 7.5.1 Bile solubility test

This helps to differentiate *S. pneumoniae*, which is soluble in bile and bile salts, from other *alpha*-haemolytic streptococci (viridans streptococci) which are insoluble.

#### Principle

A heavy inoculum of the test organism is emulsified in physiological saline and the bile salt sodium deoxycholate is added. This dissolves *S. pneumoniae* as shown by a clearing of the turbidity within 10–15 minutes. Viridans and other streptococci are not dissolved and therefore there is no clearing of the turbidity.

#### Required

- Sodium deoxycholate, Reagent No. 74  
100 g/l (10% w/v)
- Physiological saline (sodium chloride, 8.5 g/l)

#### Tube method

Although the bile solubility test can be performed by testing colonies directly on a culture plate or on a slide (see subunit 7.18.4), a tube technique is recommended because the results are easier to read.

- 1 Emulsify several colonies of the test organism in a tube containing 2 ml sterile physiological saline, to give a turbid suspension.

- 2 Divide the organism suspension between two tubes.
- 3 To one tube, add 2 drops of the sodium deoxycholate reagent and mix.
- 4 To the other tube (negative control), add 2 drops of sterile distilled water and mix.
- 5 Leave both tubes for 10–15 minutes at 35–37°C.
- 6 Look for a clearing of turbidity in the tube containing the sodium deoxycholate, as shown in Plate 7.6.

### Results

Clearing of turbidity ..... Probably  
*S. pneumoniae*

No clearing of turbidity .... Organism is probably  
not *S. pneumoniae*

There should be no clearing of turbidity in the negative control tube to which distilled water was added.

*Note:* Some strains of *S. pneumoniae* are not dissolved by bile salts, and very occasionally some strains of viridans streptococci give a positive test.

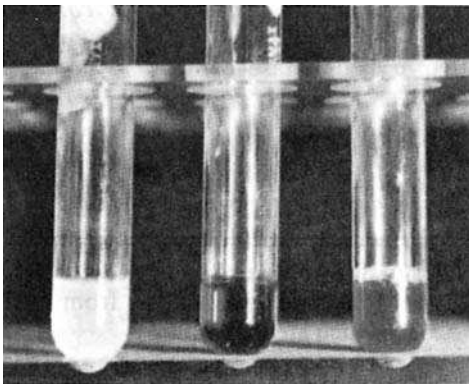

Plate 7.6 Bile solubility test. *Left:* Shows saline suspension of test organism without bile salt added. *Centre:* Shows clearing of turbidity after adding bile salt, indicating that the organism is probably *S. pneumoniae*. *Right:* Shows a negative test.

### Controls

Bile solubility positive control: *Streptococcus pneumoniae*

Bile solubility negative control: *Enterococcus faecalis*

## 7.5.2 Catalase test

This test is used to differentiate those bacteria that produce the enzyme catalase, such as staphylococci, from non-catalase producing bacteria such as streptococci.

### Principle

Catalase acts as a catalyst in the breakdown of hydrogen peroxide to oxygen and water. An organism is tested for catalase production by bringing it into contact with hydrogen peroxide. Bubbles of oxygen are released if the organism is a catalase producer. The culture should not be more than 24 hours old.

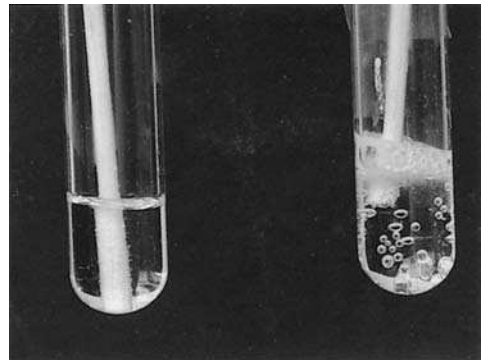

Plate 7.7 Catalase tube test. *Right:* Shows a positive test. *Left:* Shows a negative test. *Courtesy of AH Westley.*

### Required

Hydrogen peroxide, 3% H<sub>2</sub>O<sub>2</sub> (10 volume solution)

### Method

- 1 Pour 2–3 ml of the hydrogen peroxide solution into a test tube.
- 2 Using a sterile wooden stick or a glass rod (*not* a nichrome wire loop), remove several colonies of the test organism and immerse in the hydrogen peroxide solution.

*Important:* Care must be taken when testing an organism cultured on a medium containing blood because catalase is present in red cells. If any of the blood agar is removed with the organism, a false positive reaction may occur.

- 3 Look for immediate bubbling as shown in Plate 7.7.

### Results

Active bubbling ..... Positive catalase test

No bubbles ..... Negative catalase test



**Caution:** Performing the test on a slide is not recommended because of the risk of contamination from active bubbling. When the rapid slide technique is used, the hydrogen peroxide solution should be added to the organism suspension after placing the slide in a petri dish. The dish should then be covered *immediately*, and the preparation observed for bubbling through the lid.

### Controls

Positive catalase control: *Staphylococcus* species

Negative catalase control: *Streptococcus* species

## 7.5.3 Citrate utilization test

This test is one of several techniques used occasionally to assist in the identification of enterobacteria. The test is based on the ability of an organism to use citrate as its only source of carbon.

### Ways of performing a citrate test

- Using a Rosco citrate identification tablet. This is the most economical method when only a few tests are performed. The tablets have a long shelf-life and good stability in tropical climates.
- Using Simmon's citrate agar but the dehydrated medium is only available in 500 g pack size from manufacturers. After being opened the medium does not have good stability in tropical climates.

### Citrate utilization using a Rosco citrate tablet

Citrate identification tablets (code 56511) are available from Rosco Diagnostica (see Appendix 11) in a vial of 50 tablets.

- 1 Prepare a dense bacterial suspension of the test organism in 0.25 ml sterile physiological saline in small tube.
- 2 Add a citrate tablet and stopper the tube.
- 3 Incubate overnight at 35–37 °C.

### Results

Red colour . . . . . Positive citrate test

Yellow-orange colour . . . . . Negative citrate test

### Controls

A positive citrate test reaction is obtained with *Klebsiella pneumoniae* and a negative reaction with *Escherichia coli*.

### Citrate method using Simmon's citrate agar

- 1 Prepare slopes of the medium in bijou bottles as recommended by the manufacturer (store at 2–8 °C).
- 2 Using a sterile straight wire, first streak the slope with a saline suspension of the test organism and then stab the butt.
- 3 Incubate at 35 °C for 48 hours. Look for a bright blue colour in the medium.

### Results

Bright blue . . . . . Positive citrate test

No change in colour . . . . . Negative citrate test of medium

### Controls

As described above.

## 7.5.4 Coagulase test

This test is used to identify *S. aureus* which produces the enzyme coagulase.

### Principle

Coagulase causes plasma to clot by converting fibrinogen to fibrin. Two types of coagulase are produced by most strains of *S. aureus*:

- Free coagulase which converts fibrinogen to fibrin by activating a coagulase-reacting factor present in plasma. Free coagulase is detected by clotting in the tube test.
- Bound coagulase (clumping factor) which converts fibrinogen directly to fibrin without requiring a coagulase-reacting factor. It can be detected by the clumping of bacterial cells in the rapid slide test.

A tube test must *always* be performed when the result of a slide test is not clear, or when the slide test is negative and *Staphylococcus* has been isolated from a serious infection. A tube test may be required to detect some MRSA (methicillin resistant *S. aureus*) strains although some commercially available latex test kits to differentiate coagulase positive and coagulase negative staphylococci, overcome this. Before performing a coagulase test, examine a Gram stained smear to confirm that the organism is a Gram positive coccus.

### Required

EDTA anticoagulated human plasma (preferably pooled and previously HIV and hepatitis tested) or rabbit plasma. The plasma should be allowed to warm to room temperature before being used.

**Plasma:** Oxalate or heparin plasma can also be used. Do not use citrated plasma because citrate-utilizing bacteria e.g. enterococci, *Pseudomonas* and *Serratia* may cause clotting of the plasma (in tube test). Occasionally, human plasma may contain inhibitory substances which can interfere with coagulase testing. It is therefore essential to test the plasma using a known coagulase positive *S. aureus*. The plasma can be stored frozen in amounts ready for use.

#### Slide test method (detects bound coagulase)

- 1 Place a drop of distilled water on each end of a slide or on two separate slides.
- 2 Emulsify a colony of the test organism (previously checked by Gram staining) in each of the drops to make two thick suspensions.

*Note:* Colonies from a mannitol salt agar culture are not suitable for coagulase testing. The organism must first be cultured on nutrient agar or blood agar.

- 3 Add a loopful (not more) of plasma to one of the suspensions, and mix gently. Look for clumping of the organisms within 10 seconds, as shown in Plate 7.8.

No plasma is added to the second suspension. This is used to differentiate any granular appearance of the organism from true coagulase clumping.

#### Results

Clumping within 10 secs . . . . . *S. aureus*  
 No clumping within 10 secs . . . . . No bound coagulase

*Note:* Virulent strains of *Yersinia pestis* are also coagulase positive.

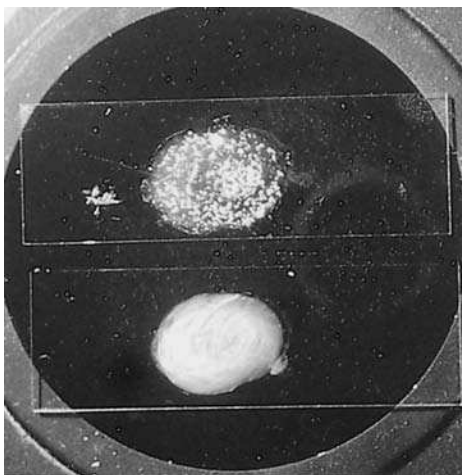

Plate 7.8 Coagulase slide test. *Upper:* Positive agglutination of *S. aureus*. *Lower:* Saline preparation to check for granularity of the strain.

#### Controls

Positive coagulase control: *Staphylococcus aureus*

Negative coagulase control: *Escherichia coli* or *Staphylococcus epidermidis*

#### Tube test method (detects free coagulase)

- 1 Take three small test tubes and label:

T = Test organism (18–24 h broth culture)\*

Pos = Positive control (18–24 h *S. aureus* broth culture)\*

Neg = Negative control (sterile broth)\*

\*Nutrient broth is suitable (see No. 63). Do not use glucose broth.

- 2 Pipette 0.2 ml of plasma into each tube.

- 3 Add 0.8 ml of the test broth culture to tube T. Add 0.8 ml of the *S. aureus* culture to the tube labelled 'Pos'.

Add 0.8 ml of sterile broth to the tube labelled 'Neg'.

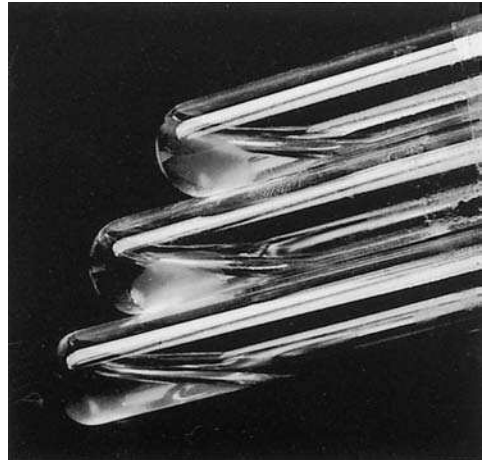

Plate 7.9 Tube coagulase test. *Upper:* *S. aureus* positive control. *Centre:* A positive test indicating the organism is *S. aureus*. *Lower:* A negative control. *Courtesy of AH Westley.*

- 4 After mixing gently, incubate the three tubes at 35–37°C. Examine for clotting after 1 hour (see Plate 7.9). If no clotting has occurred, examine after 3 hours. If the test is still negative, leave the tube at room temperature overnight and examine again.

*Note:* When looking for clotting, tilt each tube gently.

#### Results

Clotting of tube contents or . . . . . *S. aureus*  
 fibrin clot in tube

No clotting or fibrin clot . . . . . Negative test  
*Note:* There should be no clotting in the negative control tube.

### Commercially produced agglutination tests to identify *S. aureus*

Several latex agglutination test kits have been developed to identify *S. aureus* based on the detection of clumping factor, and, or protein A. These tests are discussed in 7.18.1.

## 7.5.5 DNA-ase test

This test is used to help in the identification of *S. aureus* which produces deoxyribonuclease (DNA-ase) enzymes. The DNA-ase test is particularly useful when plasma is not available to perform a coagulase test or when the results of a coagulase test are difficult to interpret.

### Principle

Deoxyribonuclease hydrolyzes deoxyribonucleic acid (DNA). The test organism is cultured on a medium which contains DNA. After overnight incubation, the colonies are tested for DNA-ase production by flooding the plate with a weak hydrochloric acid solution. The acid precipitates unhydrolyzed DNA. DNA-ase-producing colonies are therefore surrounded by clear areas due to DNA hydrolysis.

### Required

- DNA-ase agar plate No. 33  
Up to six organisms may be tested on the same plate.
- Hydrochloric acid Reagent No. 43  
1 mol/l (1 N)

### Method

- 1 Divide a DNA-ase plate into the required number of strips by marking the underside of the plate.
- 2 Using a sterile loop or swab, spot-inoculate the test and control organisms. Make sure each test area is labelled clearly.
- 3 Incubate the plate at 35–37 °C overnight.
- 4 Cover the surface of the plate with 1 mol/l hydrochloric acid solution. Tip off the excess acid.
- 5 Look for clearing around the colonies within 5 minutes of adding the acid, as shown in Plate 7.10.

### Results

Clearing around the colonies . . . . . DNA-ase positive strain

No clearing around the colonies . . . . . DNA-ase negative strain

*Note:* Some methicillin resistant *S. aureus* (MRSA) strains give a negative DNA-ase test. Some coagulase negative staphylococci are weakly positive. Also, *S. pyogenes*, *Moraxella* and *Serratia* species frequently give a positive DNA-ase test.

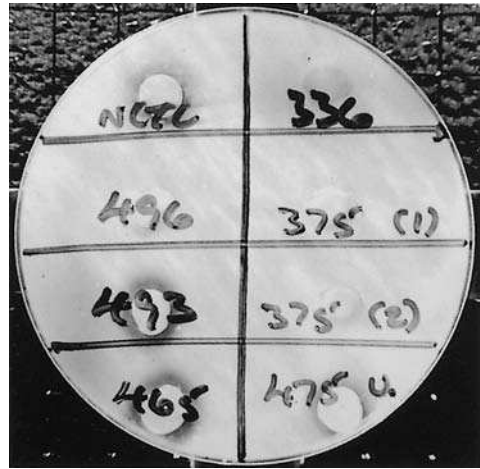

Plate 7.10 Deoxyribonuclease (DNA-ase) test. Numbers 493, 465, and 475 are positive tests indicating that the organisms are *S. aureus*. A positive *S. aureus* control strain is shown in top left section. *Courtesy of RW Davies.*

### Controls

- Positive DNA-ase control: *Staphylococcus aureus*  
 Negative DNA-ase control: *Staphylococcus epidermidis*

## 7.5.6 Indole test

Testing for indole production is important in the identification of enterobacteria. Most strains of *E. coli*, *P. vulgaris*, *P. rettgeri*, *M. morgani*, and *Providencia* species break down the amino acid tryptophan with the release of indole.

### Principle

The test organism is cultured in a medium which contains tryptophan. Indole production is detected by Kovac's or Ehrlich's reagent which contains 4 (p)-dimethylamino-benzaldehyde. This reacts with the indole to produce a red coloured compound. Kovac's reagent is recommended in preference to Ehrlich's reagent for the detection of indole from enterobacteria.

*Ways of performing an indole test*

An indole test can be performed:

- As a single test using tryptone water and Kovac's reagent.
- As a combined *beta*-glucuronidase-indole test using a Rosco PGUA/Indole identification tablet and Kovac's reagent. This is useful when identifying *E. coli*.
- As a combined lysine decarboxylase-indole test using a Rosco LDC/Indole identification tablet. This is useful in helping to identify salmonellae and shigellae (see Chart 7.8 in subunit 7.11).

**Detecting indole using tryptone water**

- 1 Inoculate the test organism in a bijou bottle containing 3 ml of sterile tryptone water.
- 2 Incubate at 35–37°C for up to 48 h.
- 3 Test for indole by adding 0.5 ml of Kovac's reagent. Shake gently. Examine for a red colour in the *surface layer* within 10 minutes.

**Kovac's indole reagent:** This can be economically purchased as a ready-made reagent from Merck (see Appendix 11). It is available in a 100 ml bottle, code 1.09293.0100 or in a 30 ml dropper bottle, code 1.11350.0001. It has a long shelf-life when stored at 4–8°C.

**Results**

Red surface layer . . . . . Positive indole test

No red surface layer . . . . . Negative indole test

*Note:* A positive indole test is shown in colour Plate 2.

**Detecting indole using Rosco PGUA/Indole tablet**

PGUA/Indole tablets (code 59011) are available from ROSCO Diagnostica (see Appendix 11), in a vial of 50 tablets. They have a long shelf life (3–4 y).

- 1 Prepare a *dense* suspension of the test organism in 0.25 ml physiological saline in a small tube.
- 2 Add a PGUA/Indole tablet and close the tube. Incubate at 35–37°C for 3–4 hours (or overnight).
- 3 First read the *beta*-glucuronidase (PGUA) reaction:

**Results**

Yellow colour . . . . . Positive PGUA test

Colourless . . . . . Negative PGUA test

- 4 Add 3 drops of Kovac's reagent (Rosco code 920–31 or other Kovac's reagent) and shake.
- 5 Wait 3 minutes before reading the indole reaction. Examine the colour of the *surface layer*.

**Results**

Red surface layer . . . . . Positive indole test

Yellow surface layer . . . . . Negative indole test

*Note:* About 94% of *E. coli* strains are PGUA positive and 99% are indole positive.

**Detecting indole using Rosco LDC/Indole tablet**

LDC/Indole tablets (code 58411) are available from Rosco Diagnostica (see Appendix 11) in a vial of 50 tablets. They have a long shelf-life (3–4 y).

- 1 Prepare a *dense* suspension of the test organism in 0.25 ml physiological saline in a small tube.
- 2 Add an LDC/Indole tablet. Add 3 drops of paraffin oil\* and close the tube.  
\*The oil overlayer provides the anaerobic conditions required for the LDC reaction.
- 3 Incubate at 35–37°C for 3–4 hours (or overnight).
- 4 First read the lysine decarboxylase (LDC) reaction:

**Results**

Blue/violet colour\* . . . . . Positive LDC test

Yellow, green or grey colour . . . . . Negative LDC test

\*If examining after overnight incubation, a positive test is indicated by a *strong* blue or violet colour.

- 5 Add 3 drops of Kovac's reagent (Rosco code 920–31 or other Kovac's reagent) and shake.
- 6 Wait 3 minutes before reading the indole reaction. Examine the colour of the *surface layer*.

**Results**

Red surface layer . . . . . Positive indole test

Yellow surface layer . . . . . Negative indole test

## 7.5.7 Litmus milk decolorization test

This test is a rapid inexpensive technique to assist in the identification of enterococci. It is based on the ability of most strains of *Enterococcus* species to reduce litmus milk by enzyme action as shown by decolorization of the litmus.

*Note:* Enterococci can also be identified using an aesculin hydrolysis test (see later text).

**Principle**

A heavy inoculum of the test organism is incubated for up to 4 hours in a tube containing litmus milk. Reduction of the litmus milk is indicated by a change in colour of the medium from mauve to white or pale yellow.

**Required**

Litmus milk medium

No. 50

**Method**

- 1 Using a sterile loop, inoculate 0.5 ml of sterile litmus milk medium with the test organism.

*Important:* A heavy inoculum of the test organism must be used. Scraping the loop three times across an area of heavy growth is recommended.

- 2 Incubate at 35–37°C for up to 4 hours, examining at half hour intervals for a reduction reaction as shown by a change in colour from mauve to white or pale yellow (compare with the positive control.) The reaction is shown in colour Plate 5.

*Note:* The incubation time should not be more than 4 hours because some strains of viridans streptococci will reduce litmus milk with prolonged incubation.

**Results**

White or pale yellow-pink colour . . . . Suggestive of  
*Enterococcus*

No change or a pink colour . . . . . Probably not  
*Enterococcus*

**Controls**

Positive control: *Enterococcus* species

Negative control: Viridans streptococci

**Note:** The work of Schierl and Blazevic\* demonstrated that up to 83% of *Enterococcus* could be identified by the rapid litmus milk reduction test. No false positive reactions were observed. A negative result can be checked by culturing the organism in aesculin broth and examining daily for up to 7 days for aesculin hydrolysis as shown by a blackening in the medium, *Enterococci* hydrolyze aesculin.

\*Schierl E. A., Blazevic D. J. Rapid identification of enterococci by reduction of litmus milk. *Journal of Clinical Microbiology*, **14**, 2, pp. 227–228, 1981.

**Aesculin hydrolysis test to identify enterococci**

This test can be economically performed using a Rosco bile aesculin tablet (*Bile aesculin* 404–21). The tablets are available from Rosco Diagnostica (see Appendix 11) in a vial of 25 tablets. They have good stability (3–4 y).

The test can be performed by placing a tablet on a blood agar plate inoculated with the test organism and incubating it at 35–37°C overnight. A positive test is indicated by the tablet and colonies around it turning black/grey. A negative test is shown by the tablet remaining white and no change in colour of the colonies. A zone of inhibition may appear around the tablet.

Alternatively, the test can be performed by making a *dense* suspension of the test organism in 0.25 ml of physiological saline in a small tube, adding a tablet, and incubating at 35–37°C for 4 hours (or overnight). A positive reaction is shown by a black/grey colour in the medium.

*Note:* An aesculin hydrolysis can also be performed by incubating the test organism on bile aesculin agar but this medium is expensive.

**7.5.8 Oxidase test\*****\*Cytochrome oxidase test**

The oxidase test is used to assist in the identification of *Pseudomonas*, *Neisseria*, *Vibrio*, *Brucella*, and *Pasteurella* species, all of which produce the enzyme cytochrome oxidase.

**Principle**

A piece of filter paper is soaked with a few drops of oxidase reagent. A colony of the test organism is then smeared on the filter paper. Alternatively an oxidase reagent strip can be used (see later text). When the organism is oxidase-producing, the phenylenediamine in the reagent will be oxidized to a deep purple colour.

Occasionally the test is performed by flooding the culture plate with oxidase reagent but this technique is not recommended for routine use because the reagent rapidly kills bacteria. It can however be useful when attempting to isolate *N. gonorrhoeae* colonies from mixed cultures in the absence of a selective medium. The oxidase positive colonies *must* be removed and subcultured within 30 seconds of flooding the plate.

*Important:* Acidity inhibits oxidase enzyme activity, therefore the oxidase test must *not* be performed on colonies that produce fermentation on carbohydrate-containing media such as TCBS or MacConkey agar. Subinoculation on nutrient agar is required before the oxidase test can be performed. Colonies tested from a medium that contains nitrate may give unreliable oxidase test results.

**Required**

Oxidase reagent *freshly* Reagent No. 64 prepared or use an oxidase reagent strip (see below)

*Note:* Fresh oxidase reagent is easily oxidized. When oxidized it appears blue and must not be used.

**Stable oxidase reagent strips**

These can be purchased from Merck (see Appendix 11) in a pack of 50 strips (code 1.13300.0001). The strips have a 5 year shelf-life when stored at 2–8°C.

**Method (fresh reagent)**

- 1 Place a piece of filter paper in a clean petri dish and add 2 or 3 drops of *freshly* prepared oxidase reagent.
- 2 Using a piece of stick or glass rod (not an oxidized wire loop), remove a colony of the test organism and smear it on the filter paper.
- 3 Look for the development of a blue-purple colour within a few seconds as shown in colour Plate 3.

**Results**

Blue-purple colour . . . . . Positive oxidase test (within 10 seconds)

No blue-purple colour . . . . . Negative oxidase test (within 10 seconds)

*Note:* Ignore any blue-purple colour that develops after 10 seconds.

**Method using an oxidase reagent strip**

- 1 Moisten the strip with a drop of sterile water.
- 2 Using a piece of stick or glass rod (not an oxidized wire loop) remove a colony of the test organism and rub it on the strip.
- 3 Look for a red-purple colour within 20 seconds.  
Red-purple colour . . . . . positive oxidase test.

*Note:* When using a Merck reagent strip, follow exactly the manufacturer's instructions on how to perform the test.

**Controls**

Positive oxidase control: *Pseudomonas aeruginosa*  
Negative oxidase control: *Escherichia coli*

strong urease producers. *Y. enterocolitica* also shows urease activity (weakly at 35–37°C). Salmonellae and shigellae do not produce urease.

**Principle**

The test organism is cultured in a medium which contains urea and the indicator phenol red. When the strain is urease-producing, the enzyme will break down the urea (by hydrolysis) to give ammonia and carbon dioxide. With the release of ammonia, the medium becomes alkaline as shown by a change in colour of the indicator to pink-red.

**Ways of performing a urease test**

- Using a Rosco urease identification tablet.
- Using modified Christensen's urea broth.

**Urease test using a Rosco urease tablet**

Urease identification tablets are available from Rosco Diagnostica (code 57511) in a vial of 50 tablets. The tablets have a long shelf-life (3–4 y).

- 1 Prepare a dense 'milky' suspension of the test organism in 0.25 ml physiological saline in a small tube.
- 2 Add a urease tablet, close the tube and incubate at 35–37°C (preferably in a water bath for a quicker result) for up to 4 hours or overnight. *Proteus* and *M. morganii* organism give a positive reaction within 4 hours.

**Results**

Red/purple colour . . . . . Positive urease test  
Yellow/orange . . . . . Negative urease test

**Urease test using Christensen's (modified) urea broth**

- 1 Inoculate heavily the test organism in a bijou bottle containing 3 ml sterile Christensen's modified urea broth (for preparation, see Appendix 1).
- 2 Incubate at 35–37°C for 3–12 h (preferably in a water bath for a quicker result).
- 3 Look for a pink colour in the medium as shown in colour Plate 4.

**Results**

Pink colour . . . . . Positive urease test  
No pink colour . . . . . Negative urease test

**7.5.9 Urease test**

Testing for urease enzyme activity is important in differentiating enterobacteria. *Proteus* strains are

## 7.6 Examination of sputum

### Possible pathogens

#### ■ BACTERIA

##### Gram positive

*Streptococcus pneumoniae*  
*Staphylococcus aureus*  
*Streptococcus pyogenes*

##### Gram negative

*Haemophilus influenzae*  
*Klebsiella pneumoniae*  
*Pseudomonas aeruginosa*  
*Proteus* species  
*Yersinia pestis*  
*Moraxella catarrhalis*

Also *Mycobacterium tuberculosis*, *Mycoplasma pneumoniae*, and *Legionella pneumophila*.

#### ■ FUNGI AND ACTINOMYCETES

*Pneumocystis jiroveci*, *Blastomyces dermatitidis*, *Histoplasma capsulatum*, *Aspergillus* species, *Candida albicans*, *Cryptococcus neoformans*, and *Nocardia* species.

#### ■ PARASITES

*Paragonimus* species (described in subunit 5.13 in Part 1 of the book).

#### Notes on pathogens

- Infection of the lungs with *M. tuberculosis* causes pulmonary tuberculosis. In developing countries tuberculosis (pulmonary and disseminated) is increasing in incidence and becoming more difficult to control (see also subunit 7.18.28). Poverty, the HIV pandemic, movement of displaced people, and emergence of multidrug-resistant strains of *M. tuberculosis* are major factors contributing to the spread of tuberculosis. Susceptibility to *M. tuberculosis* and other mycobacteria is increased with HIV infection and tuberculosis also progresses more rapidly in those with HIV disease. Tuberculosis is the commonest HIV-related disease in developing countries, causing about 30% of deaths in AIDS patients. The development of tuberculosis in HIV co-infected persons accelerates progression to full-blown AIDS.

Tuberculosis is difficult to diagnose by sputum examination in those co-infected with HIV when there is marked immunosuppression resulting in diffuse infiltration without cavitation. When immune responses are less suppressed, typical pulmonary caseating granulomas and cavities form, and AFB can usually be detected in sputum.

- *S. pneumoniae* and *H. influenzae* are the commonest causes of acute respiratory tract infections in tropical countries. *S. pneumoniae* causes lobar pneumonia and bronchopneumonia in young children (especially when malnourished), in those co-infected with HIV (major HIV-related pathogen), the elderly, the bed-ridden and other debilitated persons.
- *S. aureus*, *S. pyogenes*, and *H. influenzae* are often secondary invaders in patients with influenza virus pneumonia. *H. influenzae* is associated with acute and chronic bronchitis and chest infections in post-surgical

patients and the elderly. *S. aureus* can produce a severe pneumonia (with a tendency to form abscesses), especially in children and following influenza.

- *P. aeruginosa* is more commonly found in patients with chronic lung cavities or as a complication of treatment with immunosuppressive drugs.
- *K. pneumoniae* may be found with *E. coli* and yeasts as a complication of antibiotic therapy.
- *Moraxella catarrhalis* (formerly *Branhamella catarrhalis*) can cause upper and lower respiratory tract infections, mostly in adults with pre-existing respiratory disease and those with immunodeficiency.
- *Y. pestis* (highly infectious) can be found in the sputum of patients with pneumonic plague. The specimen may contain blood.
- *M. pneumoniae* causes primary atypical pneumonia.
- *L. pneumophila* causes Legionnaire's disease, a severe and often fatal form of pneumonia.
- *P. jiroveci* is an opportunistic fungal pathogen, causing pneumonia in those with immunosuppression. It is a common pathogen in HIV infected young children in developing countries (see subunit 7.18.55).  
*Note:* Several of the other fungi and actinomycetes listed are also associated with disease in those with immunosuppression.
- Eosinophils can be found in the sputum of patients with allergic respiratory conditions such as asthma.

### Commensals

Sputum as it is being collected passes through the pharynx and the mouth. It therefore becomes contaminated with small numbers of commensal organisms from the upper respiratory tract and mouth. These include:

#### Gram positive

*Staphylococcus aureus*  
*Staphylococcus epidermidis* (*S. albus*)  
*Viridans streptococci*  
*Streptococcus pneumoniae*  
 Enterococci  
 Micrococci  
 Lactobacilli  
 Diphtheroids  
 Yeast-like fungi

#### Gram negative

*Neisseria* species  
*Moraxella catarrhalis*  
*Haemophilus influenzae*  
 Fusobacteria  
 Coliforms

### COLLECTION AND TRANSPORT OF SPUTUM

Sputum for microbiological investigation is collected and transported as follows:

#### In a hospital with a microbiology laboratory

- 1 Give the patient a clean (need not be sterile), dry, wide-necked, leak-proof container, and request him or her to cough deeply to produce a sputum specimen.

**Caution:** When a sputum specimen is being collected, adequate safety precautions must be taken to prevent the spread of infectious organisms and to avoid contaminating the outside of the container. Use a phenol-containing disinfectant to wipe the outside of the container after collecting the specimen.

**Important:** The specimen *must* be sputum, not saliva. Sputum is best collected in the morning soon after the patient wakes and before any mouth-wash is used. When pulmonary tuberculosis is suspected, up to three specimens may need to be examined to detect AFB.

#### **Mucopus aspirated from the nasopharynx**

When it is not possible to obtain sputum from children with suspected pneumonia or bronchopneumonia, pathogens can often be isolated from mucopus aspirated from the nasopharynx.

- 2 Label the container, and complete a request form as described in subunit 7.1.
- 3 When pneumonia or bronchopneumonia is suspected, deliver the sputum to the laboratory with as little delay as possible because organisms such as *S. pneumoniae* and *H. influenzae* require culturing as soon as possible.

**Note:** Specimens for the isolation of *S. pneumoniae* and *H. influenzae* must never be refrigerated.

**When *Pneumocystis pneumonia* is suspected:** Collect broncho-alveolar lavage (BAL) or induced sputum as described in subunit 7.18.52.

**When pneumonic plague is suspected:** Deliver the sputum to the laboratory as soon as possible. Make sure the specimen is marked HIGH RISK.

#### **In a health centre for dispatch to a microbiology laboratory**

- 1 Collect the sputum in a container supplied by the microbiology laboratory (see previous text). Follow the technique and observe the precautions mentioned under the hospital collection of sputum.
- 2 To ensure the survival of pathogens such as *S. pneumoniae* and *H. influenzae*, transfer a purulent part of the sputum to a cotton-wool swab, and insert it in a container of Amies transport medium (see No. 11). Label the container using a lead pencil.

**Amies medium** will help the pathogens to survive and avoid the overgrowth of fast-multiplying commensals.

- 3 Send the sputum specimen and swab with a

request form to reach the microbiology laboratory within 6 hours. Instructions regarding the packaging of specimens can be found at the end of subunit 7.1.

## LABORATORY EXAMINATION OF SPUTUM

### Day 1

**Specimens for immediate attention:** When pneumonia or bronchopneumonia is suspected, the sputum must be cultured as soon as possible because organisms such as *H. influenzae* and *S. pneumoniae* do not survive well in specimens.

**Caution:** Whenever possible, sputum specimens should be examined in a biological safety cabinet (described in subunit 3.3 in Part 1 of the book).

#### 1 Describe the appearance of the specimen

Describe whether the sputum is:

**Purulent:** Green-looking, mostly pus  
**Mucopurulent:** Green-looking with pus and mucus  
**Mucoid:** Mostly mucus  
**Mucosalivary:** Mucus with a small amount of saliva

When the sputum contains blood, this must also be reported.

**Unsuitable sputum specimens:** When the sputum is mostly saliva, report the specimen as 'Unsuitable for microbiological investigation' and request another specimen.

**Note:** Before culturing sputum, many laboratories examine a wet preparation or Field's stained smear microscopically for cells. When large numbers of squamous epithelial cells (often covered with bacteria) are present and only a few or no pus or macrophage cells, this indicates that the specimen is unsuitable for culturing.

#### 2 Examine the specimen microscopically

##### **Gram smear**

Using a piece of stick, transfer a *purulent* part of the sputum to a glass slide, and make a thin smear. Allow the smear to air-dry in a safe place. Fix as described in subunit 7.3.2, and stain by the Gram technique (see subunit 7.3.4).

Examine the smear for pus cells and *predominant* bacteria. Look especially among the pus cells for:

- Gram positive diplococci (capsulated) that could be *S. pneumoniae* (see colour Plate 28). The



organisms, however, are not often seen and can be difficult to differentiate from the normal microbial flora.

- Gram positive cocci in groups that could be *S. aureus* (see colour Plate 24), but not often seen.
- Gram negative rods and cocco-bacilli that could be *H. influenza* (see colour Plate 48), particularly when these are the predominant organisms.
- Gram negative capsulated rods that could be *K. pneumoniae*, but not often seen.
- Gram negative diplococci in and between pus cells that could be *M. catarrhalis* (see Notes on Pathogen).

Gram stained smears of sputum must be reported with caution. Cocci, diplococci, streptococci, and rods may be seen in normal sputum because these organisms form part of the normal microbial flora of the upper respiratory tract.

*Note:* When pus cells are present but no bacteria are seen in a Gram stained smear, this may indicate the presence of microorganisms such as *M. tuberculosis*, *Chlamydomphila pneumoniae*, *Mycoplasma pneumoniae*, *Legionella pneumophila* or viruses.

### **Ziehl-Neelsen smear to detect AFB**

Studies have shown that the chances of detecting AFB in sputum smears are significantly increased when sputum is first treated with 5% v/v sodium hypochlorite (NaOCl), i.e. bleach, followed by centrifugation or overnight sedimentation (see subunit 7.18.28). Because NaOCl kills *M. tuberculosis*, the NaOCl concentration technique is also safer for laboratory staff. NaOCl treated sputum cannot be used for culture.

#### *Sodium hypochlorite centrifugation technique to concentrate AFB*

- 1 Transfer 1–2 ml of sputum (particularly that which contains any yellow caseous material) to a screw-cap *Universal* bottle or other container of 15–20 ml capacity.

*Caution:* Open specimen containers with care and at arms length to avoid inhaling infectious aerosols. When available, handle the specimen inside a safety cabinet.

- 2 Add an equal volume of concentrated sodium hypochlorite (bleach) solution and mix well.

**Sodium hypochlorite (NaOCl) solution:** This is widely available as bleach for domestic and laundering purposes,

e.g. *Domestos*, *Jik*, *Presept*, *Chlorox*, *eau de Javel* and other trade names. These domestic bleach solutions generally contain about 5% available chlorine and should be used undiluted in the NaOCl technique to concentrate AFB.

*Caution:* Bleach is corrosive and toxic when ingested or inhaled. It also has an irritating vapour and therefore it should be used in a well-ventilated place. Store it out of direct sunlight in a cool place, *away from acids, methanol and oxidizing chemicals*. When in contact with acids, sodium hypochlorite liberates toxic gas.

- 3 Leave at room temperature for 10–15 minutes, shaking at intervals to break down the mucus in the sputum.
- 4 Add about 8 ml of distilled water, or when unavailable use boiled filtered rain water. Mix well.
- 5 Centrifuge at 3000 g for 15 minutes or at 250–1000 g for 20 minutes.

*Note:* When a centrifuge is not equipped to take *Universal* containers, divide the specimen between two conical tubes (which can be capped).

When centrifugation is not possible, leave the NaOCl treated sputum to sediment overnight (see following text).

- 6 Using a glass Pasteur pipette or plastic bulb pipette, remove and discard the supernatant fluid. Mix the sediment. When two tubes have been used, combine the two sediments. Transfer a drop of the well-mixed sediment to a clean scratch-free glass slide. Spread the sediment to make a thin preparation and allow to air-dry.
- 7 Heat-fix the smear and stain it using the Ziehl-Neelsen technique (see subunit 7.3.5). Examine it microscopically for AFB. *M. tuberculosis* in Ziehl-Neelsen stained sputum smears is shown in colour Plates 56 and 57.

*Note:* Up to three specimens may need to be examined to detect *M. tuberculosis* in sputum. One specimen should be collected as an early morning sputum (see previous text).

#### **Concentration of AFB in NaOCl treated sputum following overnight sedimentation**

When a centrifuge is not available or there is no mains electricity, a study in Ethiopia\* has shown that overnight sedimentation of NaOCl treated sputum can also increase the sensitivity of smear examination. In the study, 8.5% of patients were AFB positive by direct smear examination, 25.5% following overnight sedimentation of NaOCl treated sputum, and 38% when the treated sputa were centrifuged.

\**Gebre-Selassie, S.* Evaluation of the concentration sputum

smear technique for the laboratory diagnosis of pulmonary tuberculosis. *Tropical Doctor*, 33, July, 2003.

#### ADDITIONAL

##### **Saline preparation when paragonimiasis is suspected**

Transfer a small amount of sputum, especially that which is brown-coloured and stringy, to a slide. Add a drop of physiological saline, mix, and cover with a cover glass.

Using the 10× objective with the condenser iris diaphragm closed sufficiently to give good contrast, examine the preparation for *Paragonimus* eggs. *Paragonimus* eggs are described and illustrated in subunit 5.13 in Part 1 of the book.

*Note:* Clinical and laboratory features that help to differentiate pulmonary tuberculosis from paragonimiasis are discussed in a WHO document: *Paragonimiasis and tuberculosis—Diagnostic confusion*, 1994, WHO/TUB/94.181 and WHO/HPE/94.3, available from WHO, 1211 Geneva, Switzerland—27.

##### **Eosin preparation when an allergic condition requires investigation**

Transfer a small amount of sputum to a slide. Add a small drop of alkaline eosin solution (Reagent No. 35), mix, and cover with a cover glass. Using the 10× and 40× objectives with the condenser iris closed sufficiently to give good contrast, examine the preparation for eosinophils\*.

\*Eosinophils can be easily differentiated from pus cells because they contain bright red-staining granules and a bilobed nucleus. Free eosinophilic granules may be seen in the preparation and occasionally elongated refractile Charcot Leyden crystals (formed from the material of dead eosinophils).

Large numbers of eosinophils in sputum can also be found with paragonimiasis.

##### **Potassium hydroxide (KOH) preparation when Aspergillus infection is suspected**

Transfer a small amount of sputum to a glass slide. Add a drop of potassium hydroxide solution (Reagent No. 69), mix, and cover with a cover glass.

Examine the preparation for fungi using the 10× and 40× objectives with the condenser iris diaphragm closed sufficiently to give good contrast:

**Aspergillus:** The appearance of fungal hyphae typical of *Aspergillus* species is described in subunit 7.18.49. A Gram stained preparation is shown in colour Plate 70.

##### **Giemsa and toluidine blue O preparations when Pneumocystis infection is suspected (AIDS patients)**

Making smears from broncho-alveolar lavage (BAL) or induced sputum and the examination of stained smears for *P. jiroveci* cysts and intracystic bodies are described in subunit 7.18.52.

##### **Giemsa stained preparation when histoplasmosis is suspected**

Examination of Giemsa stained smears for intracellular *Histoplasma* yeast cells is described in subunit 7.18.43.

##### **Giemsa or Wayson stained preparation when pneumonic plague is suspected**

Fix the sputum smear with methanol for 5 minutes. Stain using Giemsa technique (see subunit 7.3.10) or rapid Wayson's technique (see 7.3.8). Bipolar staining of *Y. pestis* is described in subunit 7.18.22 and shown in colour Plate 54.

*Caution:* *Y. pestis* is highly infectious (Hazard Group 3 pathogen), therefore handle specimens with great care. Laboratory-acquired infections can occur following accidental inoculation or inhalation of the organisms. Minimize procedures that create aerosols and whenever possible carry out procedures in a safety cabinet (see pp. 61–65 in Part 1 of the book).

### 3 Culture the specimen

To obtain as pure a culture as possible of a respiratory pathogen it is necessary to reduce the number of commensals inoculated. Ways of reducing commensal numbers include washing the sputum free from saliva or liquefying and diluting it. The technique using saline-washed sputum is described. The dilution technique requires a liquefying agent such as dithiothreitol (*Sputolysin*, *Sputasol*) which is expensive and unstable.

##### **Blood agar and chocolate agar**

- Wash a purulent part of the sputum in about 5 ml of *sterile* physiological saline.
- Inoculate the washed sputum on plates of:
  - Blood agar, see No. 16
  - Chocolate (heated blood) agar, see No. 16

##### **Inoculation technique to reduce commensal numbers:**

- Using the technique described in subunit 7.4 (to inoculate a whole plate of agar), *flame the loop* in between each spread. This will help to obtain a pure growth of the pathogen in the areas of the 3rd and 4th spread.
- Add an optochin disc to the blood agar plate within the area of 2nd spread. This will help to identify *S. pneumoniae* (see subunit 7.18.4).

## Summary of Microbiological Examination of Sputum

### Day 1

#### ADDITIONAL INVESTIGATIONS

- |                                  |  |   |
|----------------------------------|--|---|
| <b>1 Describe Specimen</b>       | <ul style="list-style-type: none"> <li>■ <b>Report whether specimen:</b> <ul style="list-style-type: none"> <li>– purulent, mucopurulent, mucoid, salivary</li> <li>– contains blood</li> </ul> </li> </ul>  |   |
| <b>2 Examine Microscopically</b> | <ul style="list-style-type: none"> <li>■ <b>Gram smear:</b> For pus cells and bacteria</li> <li>■ <b>Zn smear:</b> For AFB</li> </ul>  | <ul style="list-style-type: none"> <li>■ <b>Giemsa smear:</b> When pneumonic plague or histoplasmosis is suspected</li> <li>■ <b>KOH preparation:</b> When <i>Aspergillus</i> infection is suspected</li> <li>■ <b>Toluidine blue-O and Giemsa smears:</b> When <i>Pneumocystis pneumonia</i> is suspected</li> <li>■ <b>Eosin preparation:</b> When an allergic condition requires investigation</li> <li>■ <b>Saline preparation:</b> When paragonimiasis is suspected</li> </ul> |
| <b>3 Culture Specimen</b>        | <ul style="list-style-type: none"> <li>■ <b>Blood agar</b> <ul style="list-style-type: none"> <li>– Add an optochin disc</li> <li>– Incubate aerobically</li> </ul> </li> <li>■ <b>Chocolate agar</b> <ul style="list-style-type: none"> <li>– Incubate in CO<sub>2</sub></li> </ul> </li> </ul> | <ul style="list-style-type: none"> <li>■ <b>Culture for <i>M. tuberculosis</i></b> (In Reference Laboratory)<br/>See text</li> </ul>  |

### Day 2 and Onwards

- |                                      |  |   |
|--------------------------------------|--|---|
| <b>4 Examine and Report Cultures</b> | <ul style="list-style-type: none"> <li>■ <b>Blood and chocolate agar cultures</b><br/>Report <i>significant</i> growth of:<br/><i>S. pneumoniae</i><br/><i>H. influenzae</i><br/><i>S. aureus</i><br/><br/>Less commonly found pathogens:<br/><i>K. pneumoniae</i>, <i>P. aeruginosa</i>,<br/><i>M. catarrhalis</i>, <i>S. pyogenes</i>,<br/><i>Proteus</i>, <i>C. albicans</i></li> </ul> | <ul style="list-style-type: none"> <li>■ Test <i>H. influenzae</i> for beta-lactamase production</li> <li>■ Antimicrobial susceptibility tests as required</li> </ul> |
|--------------------------------------|--|---|

**Key:** Zn = Ziehl-Neelsen, KOH = Potassium hydroxide, CO<sub>2</sub> = Carbon dioxide

**Availability:** Optochin discs can be purchased economically from Mast Diagnostics (see Appendix 11) in vials of 100 discs, code D-42. They have a shelf-life of about 2 years.

- Incubate the blood agar plate aerobically and the chocolate agar plate in a carbon dioxide enriched atmosphere (see subunit 7.4).

#### ADDITIONAL

##### **Culture of sputum for *M. tuberculosis***

Culturing and susceptibility testing of *M. tuberculosis* are usually undertaken in a Tuberculosis Reference Laboratory, mainly for surveillance purposes, to determine levels of drug resistance, and to manage treatment failures and relapses (see also subunit 7.18.28).

##### **Culture of sputum when pneumonic plague is suspected**

Isolation of *Y. pestis* is described in subunit 7.18.22.

### Day 2 and Onwards

#### 4 Examine and report the cultures

##### **Blood agar and chocolate agar cultures**

Look especially for a significant growth of:

- *Streptococcus pneumoniae* sensitive to optochin, see subunit 7.18.4
- *Haemophilus influenzae*, see subunit 7.18.24
- *Staphylococcus aureus*, see subunit 7.18.1

##### **Less frequently isolated pathogens**

*Klebsiella pneumoniae*, see subunit 7.18.17

*Pseudomonas aeruginosa*, see subunit 7.18.20

*Moraxella catarrhalis*, see end of subunit 7.18.24

*Streptococcus pyogenes*, see subunit 7.18.2

*Proteus* species, see subunit 7.18.18

*Candida albicans*, see subunit 7.18.47

##### **Antimicrobial susceptibility testing**

Susceptibility tests should be performed only when the amount of cultural growth of a pathogen is significant. Strains of *S. pneumoniae* should be tested on blood agar for susceptibility to penicillin, tetracycline, and erythromycin. Penicillin susceptibility is best determined using an oxacillin 1 µg disc. A zone size less than 20 mm indicates reduced susceptibility. *H. influenzae* strains should be tested for beta-lactamase production (see end of subunit 7.16) and susceptibility to ampicillin, tetracycline, and co-trimoxazole. Susceptibility testing of *S. aureus* strains is described in subunit 7.16.

## 7.7 Examination of throat and mouth specimens

#### Possible pathogens

##### ■ BACTERIA

###### **Gram positive**

*Streptococcus pyogenes*

*Corynebacterium*

*diphtheriae*

*Corynebacterium ulcerans*

###### **Gram negative**

Vincent's organisms

##### ■ VIRUSES

Respiratory viruses, enteroviruses and herpes simplex virus type 1.

##### ■ FUNGI

*Candida albicans* and other yeasts.

*Note:* Pathogens in the upper respiratory tract such as *Bordetella pertussis*, *Streptococcus pneumoniae*, and *Neisseria meningitidis*, are usually more successfully isolated from naso-pharyngeal secretions collected by aspiration.

#### Notes on pathogens

- *S. pyogenes*, Lancefield Group A beta-haemolytic *Streptococcus* is the commonest cause of bacterial pharyngitis (sore throat), especially in young children. Its association with rheumatic heart disease and importance in developing countries are discussed in subunit 7.18.2. The term scarlet fever is used when streptococcal pharyngitis is accompanied by a characteristic skin rash.
- *C. diphtheriae* produces a powerful and often fatal exotoxin and therefore when diphtheria is suspected, the patient is treated immediately with antitoxin. The role of the laboratory is to confirm the clinical diagnosis.
- *C. albicans* infection of the mouth (oral thrush) is common in those with HIV disease. It may also affect young children, those who have been treated with antibiotics over a long period, and occasionally diabetic patients and those with other systemic diseases.
- Infection with Vincent's organisms (*Borrelia vincenti* in association with Gram negative anaerobic fusiform bacilli) causes Vincent's angina (Vincent's gingivitis), an ulcerative tonsillitis with tissue necrosis.

#### Commensals

##### **Gram positive**

Viridans streptococci

Non-haemolytic streptococci

*Streptococcus pneumoniae*

*Staphylococcus epidermidis*

Micrococci

##### **Gram negative**

*Moraxella catarrhalis*

*Neisseria pharyngitidis*

Fusobacteria

Coliforms

*Bacteroides* species

*Haemophilus influenzae*

Lactobacilli (mostly non-capsulate strains)  
Diphtheroids

Also various spirochaetes, actinomycetes, aerobic and anaerobic spore-bearers, and yeasts.

### COLLECTION AND TRANSPORT OF THROAT AND MOUTH SWABS

Whenever possible throat and mouth swabs should be collected by a medical officer or experienced nurse.

#### *In a hospital with a microbiology laboratory*

- In a good light and using the handle of a spoon to depress the tongue, examine the inside of the mouth. Look for inflammation, and the presence of any membrane, exudate, or pus.
  - With diphtheria, a greyish-yellow membrane (later becoming greyish green-black and smelly) can often be seen extending forwards over the soft palate and backwards onto the pharyngeal wall.
  - With a streptococcal sore throat, the tonsils are inflamed and often covered in yellow spots.
  - With *C. albicans* infection, patches of white exudate may be seen attached in places to the mucous membrane of the mouth.
  - With Vincent's angina, there is ulceration of the mouth, throat, or lips. Viral tonsillitis can also cause ulceration of the tonsils.
- Swab the affected area using a sterile cotton-wool swab. Taking care not to contaminate the swab with saliva, return it to its sterile container.  
*Important:* For 8 hours before swabbing, the patient must not be treated with antibiotics or antiseptic mouth-washes (gargles).  
*Caution:* It can be dangerous to swab the throat of a child with acute haemophilus epiglottitis because this may cause a spasm that can obstruct the child's airway. Blood for culture should be collected instead.
- Within two hours of collection, deliver the swab with a completed request form to the laboratory.

#### *In a health centre for dispatch to a microbiology laboratory*

- Using a sterile swab (supplied in a tube of silica gel by the microbiology laboratory), collect a specimen from the infected area as described under the hospital collection of throat swabs.
- Taking care not to contaminate the swab, return it to its tube. Seal with adhesive tape and label the tube.

- Send the swab with a completed request form to reach the microbiology laboratory within 3 days. Instructions regarding the packaging and dispatch of specimens can be found at the end of subunit 7.1.

#### **Transport of swabs in tubes containing silica gel**

It has been shown that *S. pyogenes* will remain viable for at least 3 days (at ambient temperatures) on swabs stored in tubes containing 3–5 g of *dessicated* silica gel.

*Note:* Other systems for transporting specimens to be investigated for *S. pyogenes* are described in the WHO publication *Laboratory diagnosis of group A streptococcal infections*.<sup>1</sup>

## LABORATORY EXAMINATION OF THROAT and MOUTH SPECIMENS

### Day 1

#### 1 Culture the specimen

##### *Blood agar*

- Inoculate the swab on a plate of blood agar (see No. 16). Use the loop to make also a few stabs in the agar (well area). Colonies of *S. pyogenes* growing below the surface will show more distinct zones of haemolysis because of the anaerobic conditions provided.
- When a swab is received in silica gel (e.g. from a health centre), moisten it first with sterile nutrient broth and then inoculate the plate.
- Add a 0.05 unit bacitracin disc (Reagent No. 15) to the plate. This will help in the identification of *S. pyogenes* (see subunit 7.18.2). Some workers also add a co-trimoxazole disc (as used for susceptibility testing) which prevents the growth of other bacteria, making it easier to see *beta*-haemolytic *S. pyogenes* colonies.
- Incubate the plate preferably anaerobically or, when this is not possible, in a carbon dioxide enriched atmosphere overnight at 35–37°C. Candle jar incubation will detect most *beta*-haemolytic streptococci.

*Note:* *Beta*-haemolytic streptococci produce larger zones of haemolysis when incubated anaerobically. A minority of Group A *Streptococcus* strains will only grow anaerobically.

#### **Immunological detection of *S. pyogenes* antigen in specimens**

Immunochemical tests, dip sticks and other simple to perform technologies have been developed to detect *S. pyogenes* antigen directly in specimens. These tests are described in subunit 7.18.2.

## ADDITIONAL

**Culture of specimen when diphtheria is suspected**

When diphtheria is suspected and culture is *specifically requested*, inoculate the swab on Tinsdale medium or tellurite blood agar (see subunit 7.18.7). Incubate the plate aerobically at 35–37°C for up to 48 hours, examining for growth after overnight incubation.

*Note:* The isolation of *Bordetella pertussis* from nasopharyngeal secretions is described in subunit 7.18.25.

**2 Examine the specimen microscopically****Gram smear**

Make an evenly spread smear of the specimen on a slide. Allow the smear to air-dry in a safe place. Fix as described in subunit 7.3.2, and stain by the Gram technique (see subunit 7.3.4). Use dilute carbol fuchsin (1 in 10 dilution) as the counterstain in preference to safranin or neutral red (stains Vincent's organisms better).

Examine the smear for pus cells and Vincent's organisms:

*Vincent's organisms:* These are seen as Gram negative spirochaetes (*B. vincenti*) and Gram negative fusiform rods as shown in colour Plate 65.

**Other bacteria:** No attempt should be made to report *routinely* other bacteria in a Gram stained smear from a throat swab because the throat contains a wide variety of commensals that cannot be distinguished morphologically from pathogens.

When thrush is suspected, look for Gram positive *Candida* yeast cells (see colour Plate 72).

## ADDITIONAL

**Albert stained smear when diphtheria is suspected**

Prepare the smear as described previously under Gram smear. Fix with alcohol (see subunit 7.3.2) and stain by the Albert staining technique (see subunit 7.3.9). Examine the smear for bacteria that could be *C. diphtheriae*.

Look for pleomorphic rods containing dark-staining volutin granules as shown in colour Plate 32. The pleomorphic rods tend to join together at angles giving the appearance of Chinese letters. Pleomorphism and granule formation are best seen in smears from a Loeffler serum or Dorset egg

medium culture. Smears directly from specimens may not show these features.

**Volutin granules**

Although the presence of volutin granules is characteristic of *C. diphtheriae*, especially when the organisms are pleomorphic, some virulent strains of the *gravis* biovar (biotype) may contain few or no volutin granules. It is also possible for commensal diphtheroids to contain volutin granules but the commensals are not pleomorphic like *C. diphtheriae*.

When *C. diphtheriae* is cultured on tellurite blood agar and modified Tinsdale medium, granule formation is usually restricted.

*Note:* In Gram stained smears, *C. diphtheriae* stains variably and weakly Gram positive, whereas commensal diphtheroids appear strongly Gram positive.

**Day 2 and Onwards****3 Examine and report the cultures****Blood agar culture**

Look for *beta*-haemolytic colonies that could be *Streptococcus pyogenes* (Lancefield Group A *Streptococcus*). Most strains are sensitive to bacitracin as shown in colour Plate 26. However, bacitracin sensitivity cannot be completely relied on to identify *S. pyogenes*. The organism should be tested serologically to confirm that it belongs to Lancefield Group A or tested biochemically using the PYR test (see following text).

**Lancefield grouping of beta-haemolytic streptococci**

*Beta*-haemolytic streptococci are grouped by their specific cell wall polysaccharide antigens (C substance) using specific antiserum. *S. pyogenes* belongs to Group A. Simple to use latex and co-agglutination slide test kits are available for grouping *beta*-haemolytic streptococci. Details of these can be found in subunit 7.18.2.

**PYR test for the presumptive identification of S. pyogenes**

*S. pyogenes* produces the enzyme pyrrolidonyl peptidase which is able to break down the substrate L-pyrrolidonyl-beta-naphthylamide (PYR). The reaction is detected using an aminopeptidase reagent. Details of the test and its availability in a simple to use tablet form can be found in subunit 7.18.2.

**Isolation and identification of C. diphtheriae**

The cultural features of *C. diphtheriae* on Tinsdale medium and tellurite blood agar (TBA) are described in subunit 7.18.7. When colonies suspected of being *C. diphtheriae* are isolated, identify as follows:

- Examine a Gram stained smear for variable staining pleomorphic rods as shown in colour Plate 33.
- Subinoculate two slopes of Dorset egg medium (see No. 34) or Loeffler serum agar (see No. 52). Incubate at 35–37°C for 6 hours or until sufficient growth is obtained.

Examine an Albert stained smear of the subculture for pleomorphic rods containing volutin granules (see colour Plate 32). Examine a Gram stained smear to check that the subculture is a pure growth.

- Identify the isolate biochemically as described in subunit 7.18.7.
- Using the growth from the other subculture, test the strain for toxin production using the Elek precipitation technique as described in subunit 7.18.7.

### Antimicrobial susceptibility testing

WHO in its publication *Basic Laboratory Procedures*

in *Clinical Bacteriology*<sup>2</sup> advises that routine susceptibility tests on throat or pharyngeal isolates are most often not required, and may even be misleading. The major pathogens involved in bacterial pharyngitis are *S. pyogenes* and *C. diphtheriae*. Benzylpenicillin and erythromycin are considered as the antibiotics of choice to treat both types of infection. In cases of diphtheria, treatment with antitoxin is also indicated.

#### REFERENCES

- 1 *Laboratory diagnosis of group A streptococcal infections*, WHO, 1996. ISBN 9241544953. Obtainable from WHO Publications, 1211 Geneva, 27-Switzerland.
- 2 *Basic laboratory procedures in clinical bacteriology*, WHO, 2nd edition, 2003.

## Summary of Microbiological Examination of Throat and Mouth Swabs

### Day 1

#### 1 Culture Specimen

- **Blood agar**
  - Add a bacitracin disc
  - Incubate, preferably anaerobically (or in CO<sub>2</sub>)

#### ADDITIONAL INVESTIGATIONS

- **MTM or TBA:** When diphtheria suspected

#### 2 Examine Microscopically

- **Gram smear**  
Look for:
  - Pus cells and Gram negative Vincent's organisms
  - Gram positive pleomorphic rods when diphtheria suspected
  - Gram positive yeast cells when thrush suspected

- **Giemsa or Wayson's smear:**  
When diphtheria suspected

### Day 2 and Onwards

#### 3 Examine and Report Cultures

- **Blood agar culture**  
Look for *beta*-haemolytic streptococci, sensitive to bacitracin.  
**Identify as *S. pyogenes***  
Lancefield group  
PYR test

- **MTM or TBA cultures**  
Examine for growth of *C. diphtheriae*

**Key:** MTM = Modified Tinsdale medium, TBA = Tellurite blood agar

## 7.8 Examination of pus, ulcer material and skin specimens

*Note:* The collection and examination of effusions, i.e. synovial, pleural, pericardial and ascitic fluids are described in subunit 7.9.

### PUS

#### Possible pathogens\*

\*It is impossible to list all the pathogens that may be found in pus. Those listed are the more commonly isolated pathogens from wounds, abscesses, burns, and draining sinuses.

#### ■ BACTERIA

##### Gram positive

*Staphylococcus aureus*  
*Streptococcus pyogenes*  
*Enterococcus* species  
 Anaerobic streptococci  
 Other streptococci  
*Clostridium perfringens*  
 and other clostridia  
 Actinomycetes  
*Actinomyces israeli*

Also *Mycobacterium tuberculosis*

##### Gram negative

*Pseudomonas aeruginosa*  
*Proteus* species  
*Escherichia coli*  
*Bacterioides* species  
*Klebsiella* species  
*Pasteurella* species

#### ■ FUNGI

*Histoplasma c. duboisii*, see 7.18.43

*Candida albicans*, see 7.18.47

Fungi that cause mycetoma are described in subunit 7.18.41.

#### ■ PARASITES

*Entamoeba histolytica*

(in pus aspirated from an amoebic liver abscess), see subunit 5.14.1 in Part 1 of the book

### Commensals

Any commensal organisms found in pus are usually those that have contaminated the specimen from skin, clothing, soil, or from the air if an open wound.

### ULCER MATERIAL AND SKIN SPECIMENS

#### Possible pathogens

#### ■ BACTERIA

##### Gram positive

*Staphylococcus aureus*  
*Streptococcus pyogenes*  
*Enterococcus* species  
 Anaerobic streptococci  
*Erysipelothrix rhusiopathiae*  
*Bacillus anthracis*

##### Gram negative

*Escherichia coli*  
*Proteus*  
*Pseudomonas aeruginosa*  
*Yersinia pestis*  
 Vincent's organisms

Also *Mycobacterium leprae*, *Mycobacterium ulcerans*, *Treponema carateum*, and *Treponema pertenue*.

*Note:* Pathogens that may be found in specimens from genital ulcers are described in subunit 7.10.

#### ■ VIRUSES

Poxviruses and herpes viruses

#### ■ FUNGI

Dermatophytes (ringworm fungi) see 7.18.38

*Malassezia furfur*, see 7.18.39

Fungi that cause chromoblastomycosis, see 7.18.40

*Candida albicans*, see 7.18.47

#### ■ PARASITES

*Leishmania* species\*

*Onchocerca volvulus*\*

*Dracunculus medinensis*\*

\*These parasites are described in Part 1 of the book.

### Commensals

Commensal organisms that may be found on the skin include:

#### Gram positive

Staphylococci  
 Micrococci  
 Anaerobic cocci  
 Viridans streptococci  
 Enterococci  
 Diphtheroids  
*Propionibacterium acnes*

#### Gram negative

*Escherichia coli*  
 and other coliforms

### Notes on pathogens

- *S. aureus* is the commonest pathogen isolated from subcutaneous abscesses and skin wounds. It also causes impetigo (small pustules that form yellow crusty sores, usually around the mouth). Penicillin and methicillin resistant strains of *S. aureus* are common causes of hospital-acquired wound infections.
- *P. aeruginosa* is associated with infected burns and hospital-acquired infections.
- *E. coli*, *Proteus* species, *P. aeruginosa*, and *Bacterioides* species are the pathogens most frequently isolated from abdominal abscesses and wounds. Pus containing *Bacterioides* species has a very unpleasant smell (as also pus containing other anaerobes).
- *C. perfringens* is found mainly in deep wounds where anaerobic conditions exist. The toxins produced cause putrefactive decay of the infected tissue with gas production. The death and decay of tissue by *C. perfringens* is called gas gangrene (see subunit 7.18.9).
- Chronic leg ulceration is common in those with sickle cell disease. The commonest pathogens isolated are *S. aureus*, *P. aeruginosa*, *S. pyogenes*, and *Bacterioides* species.
- *M. tuberculosis* is associated with 'cold' abscesses.
- Actinomycetes (filamentous bacteria) and several species of fungi cause mycetoma (see subunit 7.18.41). Specimens



of pus from the draining sinuses contain granules, examination of which helps to differentiate whether the mycetoma is bacterial (treatable) or fungal (less easily treated).

- *A. israeli* and other species of *Actinomyces* cause actinomycosis (see 7.18.31). Small yellow granules can be found in pus from a draining sinus (often in the neck).
- Vincent's organisms (*Borrelia vincenti* with Gram negative anaerobic fusiform bacilli) are associated with tropical ulcer (see p. 228). The ulcer is commonly found on the leg, often of malnourished persons, especially children. Staphylococci and streptococci are frequently secondary invaders.
- *B. anthracis* causes anthrax, with the cutaneous form of the disease producing a pustule usually on the hand or arm (see 7.18.6). The fluid from the pustule is highly infectious.
- *Y. pestis* causes plague (see 7.18.22). The disease is referred to as bubonic plague when the organism infects a lymph gland and produces a painful swelling referred to as a bubo. The organism can be found in the fluid aspirated from the bubo and in the surrounding inflamed tissue. The organism is highly infectious.
- *M. leprae* can be found in skin smears in lepromatous leprosy and occasionally also in borderline forms of the disease (see 7.18.30).
- *M. ulcerans* causes *M. ulcerans* disease (buruli ulcer). The countries in which the disease occurs are listed in 7.18.29.
- *E. rhusiopathiae* causes erysipeloid, a rare inflammatory skin condition, usually affecting the finger or hand of those handling meat, poultry, or fish.
- *T. carateum* causes pinta (see 7.18.32). It is found in southern Mexico, Central America and Columbia.
- *T. pertenuis* causes yaws (see 7.18.32). It is found in tropical Africa (especially in West Africa), Central America, and also in parts of South-east Asia.
- Skin diseases (bacterial and fungal) are common in those with HIV diseases. Bacterial infections include recurrent infections caused by *S. aureus* and *S. pyogenes*.

#### COLLECTION AND TRANSPORT OF PUS, ULCER MATERIAL, SKIN SPECIMENS

Specimens should be collected by a medical officer or an experienced nurse. Pus from an abscess is best collected at the time the abscess is incised and drained, or after it has ruptured naturally. When collecting pus from abscesses, wounds, or other sites, special care should be taken to avoid contaminating the specimen with commensal organisms from the skin. As far as possible, a specimen from a wound should be collected before an antiseptic dressing is applied.

#### **In a hospital with a microbiology laboratory**

- 1 Using a sterile technique, aspirate or collect from a drainage tube up to 5 ml of pus. Transfer to a leak-proof sterile container.

When pus is not being discharged, use a sterile cotton-wool swab to collect a sample from the infected site. Immerse the swab in a container of Amies transport medium (see No. 11).

- 2 Label the specimen and as soon as possible deliver it with a completed request form to the laboratory.

*When mycetoma is suspected:* Obtain a specimen from a draining sinus tract using a sterile hypodermic needle to lift up the crusty surface over the sinus opening. This method of specimen collection has the advantages that the pus obtained is usually free from secondary organisms and the draining granules can usually be seen clearly and removed for microscopical examination. Transfer the pus to a sterile container.

*When tuberculosis is suspected:* Aspirate a sample of the pus and transfer it to a sterile container.

*When the tissue is deeply ulcerated and necrotic* (full of dead cells): Aspirate a sample of infected material from the side wall of the ulcer using a sterile needle and syringe. Transfer to a sterile container.

*Fluid from pustules, buboes, and blisters:* Aspirate a specimen using a sterile needle and syringe. Transfer to a sterile container.

*Serous fluid from skin ulcers, papillomas, or papules, that may contain treponemes:* Collect a drop of the exudate directly on a clean cover glass and invert it on a clean slide. Immediately deliver the specimen to the laboratory for examination by dark-field microscopy.

*Skin specimens for ringworm fungi:* Collect and examine as described in subunit 7.18.38.

*Skin smears for M. leprae:* Collect and examine as described in subunit 7.18.30.

**Caution:** Specimens from patients with suspected plague or anthrax are highly infectious. Label such specimens HIGH RISK and handle them with care.

#### **In a health centre for dispatch to a microbiology laboratory**

- 1 Collect the specimen using a sterile cotton-wool swab. Insert it in a container of Amies transport medium (see No. 11), breaking off the swab stick to allow the bottle top to be replaced tightly.

When the material is aspirated fluid from a

pustule, transfer the fluid to a sterile, leak-proof container. Stopper, and seal in a leak-proof plastic or metal container.

*Note:* It is not possible to transport exudate from a suspected treponemal ulcer because the treponemes remain motile for only a short time.

- 2 Make a smear of the material on a clean slide (for Gram staining) and allow to air-dry in a safe place. Heat-fix the smear (see subunit 7.3.2).

*Caution:* Do *not* make a smear for transporting when the specimen is from a patient with suspected anthrax or bubonic plague.

- 3 Send the specimens with a completed request form to reach the microbiology laboratory within 6 hours. Instructions regarding the packaging and transport of specimens can be found at the end of subunit 7.1.

## LABORATORY EXAMINATION OF PUS, ULCER AND SKIN SPECIMENS

### Day 1

#### 1 Describe the appearance of the specimen

When from a patient with suspected mycetoma or actinomycosis, report the appearance of the specimen and whether it contains granules.

##### Detection of granules

White, yellow, brown, red, or black granules of varying size, shape, and consistency may be found in pus draining from sinuses in mycetoma (actinomycetic or fungal) and in actinomycosis. The granules are colonies of organisms.

To free the granules from the pus, shake a portion of the specimen (or dressing) in sterile distilled water. Wait for a few minutes (to allow the granules to settle), remove the supernatant fluid, and transfer a few of the granules to a slide. A hand magnifying lens may be required to see clearly the small granules.

*Note:* Identification of organisms that cause mycetoma is described in subunit 7.18.41 and actinomycosis in subunit 7.18.31.

#### 2 Examine the specimen microscopically

*Note:* When a swab has been used to collect the pus, inoculate the culture media *first* before using the swab to make smears.

##### Gram smear

Make an evenly spread smear of the specimen on a

slide. Allow the smear to air-dry in a safe place. Fix as described in subunit 7.3.2, and stain by the Gram technique (see subunit 7.3.4).

Examine the smear for bacteria among the pus cells using the 40× and 100× objectives. Look especially for:

- Gram positive cocci that could be *S. aureus* (see colour Plate 24) or streptococci that could be *S. pyogenes* or other *beta*-haemolytic streptococci, anaerobic streptococci, or enterococci (see colour Plate 25).
- Gram negative rods that could be *Proteus* species, *E. coli* or other coliforms, *P. aeruginosa* or *Bacteroides* species.
- Gram positive large rods with square ends that could be *C. perfringens* or *B. anthracis* (see colour Plate 34).
- Large numbers of pleomorphic bacteria (streptococci, Gram positive and Gram negative rods of various size and fusiform bacteria), associated with anaerobic infections.
- Gram positive yeast cells with pseudohyphae, suggestive of *Candida albicans* (see colour Plate 72).
- Vincent's organisms if tropical ulcer is suspected. These appear as Gram negative spirochaetes (*B. vincenti*) and Gram negative fusiform rods (see colour Plate 65).

#### ADDITIONAL

##### **Ziehl-Neelsen smear when tuberculosis or *M. ulcerans* disease is suspected**

Make a smear of the specimen as described under Gram smear and allow to air-dry in a safe place. Fix and stain by the Ziehl-Neelsen technique as described in subunit 7.3.5. Examine the smear for acid fast bacilli (AFB) using the 100× objective. The appearance of AFB in a Ziehl-Neelsen stained smear is shown in colour Plate 56. *M. tuberculosis* is described in subunit 7.18.28 and *M. ulcerans* in subunit 7.18.29.

*Note:* Staining smears for *M. leprae* is described in 7.18.30.

##### **Giemsa or Wayson's stained smear when bubonic plague is suspected** (see also subunit 7.18.22)

Make an evenly spread smear of the specimen on a slide and allow to air-dry in a safe place. Fix with methanol for 5 minutes and stain by the Giemsa technique (see subunit 7.3.10) or by the rapid Wayson technique (see subunit 7.3.8). Look for

Gram negative bipolar stained organisms. *Y. pestis* organisms are shown in colour Plate 54 and described in subunit 7.18.22.

*Caution:* *Y. pestis* is highly infectious.

### **Polychrome Loeffler methylene blue smear when cutaneous anthrax is suspected**

Make an evenly spread smear of the specimen on a slide and allow to air-dry in a safe place. Fix the smear by covering it with potassium permanganate 40 g/l solution (Reagent No. 71) for 10 minutes. Wash off with water, and stain as described in subunit 7.3.7.

Examine the smear for chains of large blue-stained rods surrounded by mauve stained capsules characteristic of *B. anthracis* as shown in colour Plate 55 (McFadyean's reaction). See also subunit 7.18.6.

*Caution:* *B. anthracis* is highly infectious.

### **Examination by dark-field microscopy to detect treponemes**

The examination of a specimen by dark-field microscopy for motile treponemes when yaws or pinta is suspected, is the same as that described for syphilis (see subunit 7.10). *T. pertenue* and *T. carateum* are identical in morphology to *T. pallidum* as shown in Plate 60.

### **Potassium hydroxide preparation when ringworm or other superficial fungal infection is suspected**

The examination of a potassium hydroxide preparation for the detection of ringworm fungi is described in subunit 7.18.38 and *M. furfur* in 7.18.39. Examination of preparations for fungi that cause chromoblastomycosis is described in subunit 7.18.40.

## **3 Culture the specimen**

### **Blood agar MacConkey agar, cooked meat medium (or thioglycollate broth)**

- Inoculate the specimen:
- On blood agar (see No. 16) to isolate *S. aureus* and streptococci. Add a bacitracin disc if streptococci are seen in the Gram smear.
- On MacConkey agar (see No. 54) to isolate Gram negative rods.
- Into cooked meat medium (see No. 27) or thioglycollate broth (see No. 80).

**Cooked meat medium:** This is an enrichment medium for aerobes and anaerobes. The glucose in the medium helps to produce a rapid growth of anaerobes (at the bottom of the medium).

- Incubate the inoculated blood agar plate at 35–37°C in a carbon dioxide atmosphere (candle jar) and the MacConkey agar plate aerobically. Incubate the inoculated cooked meat medium at 35–37°C for up to 72 hours. Subculture at 24 h, and if indicated at 48 h and 72 h.

### *Anaerobic culture*

When an anaerobic infection is suspected (specimen is often foul-smelling), or the Gram smear shows an 'anaerobic mixed flora', inoculate a second blood agar plate and incubate it anaerobically (see subunit 7.4) for up to 48 hours. The anaerobic blood agar plate may be made selective by adding neomycin to it (see No. 16). At a final neomycin concentration of 50–70 µg/ml, the majority of facultative anaerobic Gram negative rods will be inhibited. To aid detection of anaerobes, a metronidazole disc (5 µg) may be added to the anaerobic blood plates as the majority of anaerobes show a zone of inhibition, whereas aerobes grow up to the disc.

## **ADDITIONAL**

### **Culture of specimen when bubonic plague is suspected**

The Central Public Health Laboratory should be notified at the earliest opportunity when plague is suspected. Whenever possible, isolation of *Y. pestis* should be undertaken in this laboratory. Blood or a bubo aspirate should be sent for culturing together with a full case history and the report of the microscopical examination, i.e. whether bipolar stained organisms were seen (see subunit 7.18.22).

### **Culture of specimen when infection with *M. tuberculosis* or *M. ulcerans* is suspected**

The facilities of a specialist tuberculosis laboratory are required for the isolation, identification and susceptibility testing of *M. tuberculosis*, *M. ulcerans*, and other mycobacteria.

## **Day 2 and Onwards**

## **4 Examine and report the cultures**

### **Blood agar and MacConkey agar cultures**

Look especially for colonies that could be:

- *Staphylococcus aureus* (see subunit 7.18.1)
- *Streptococcus pyogenes* (see 7.18.2)
- *Pseudomonas aeruginosa* (see 7.18.20)
- *Proteus* species (see 7.18.18)
- *Escherichia coli* (see 7.18.14)
- *Enterococcus* species (see 7.18.5)
- *Klebsiella* species (see 7.18.17)

## Summary of Microbiological Examination of Pus, Ulcer Material and Skin Specimens

### Day 1

#### ADDITIONAL INVESTIGATIONS

#### 1 Describe Specimen

- **Look for granules:** When mycetoma or actinomycosis is suspected

#### 2 Culture Specimen

- **Blood agar**  
Incubate aerobically
- **MacConkey agar**  
Incubate aerobically
- **Cooked meat medium**  
Subculture at 24 h, 48 h, and 72 h as indicated
- **Neomycin blood agar when anaerobic infection is suspected**  
Incubate anaerobically up to 48 h

- **Culture for *M. tuberculosis* or *M. ulcerans***  
Requires facilities of a Tuberculosis Reference Laboratory

#### 3 Examine Microscopically

- **Gram smear**  
For pus cells and bacteria

- **Ziehl-Neelsen smear:**  
When tuberculosis or *M. ulcerans* disease is suspected
- **KOH preparation:**  
When a fungal or actinomycete infection is suspected
- **Giemsa or Wayson's smear:**  
When bubonic plague is suspected
- **Polychrome methylene blue:**  
When cutaneous anthrax is suspected
- **Dark-field microscopy:**  
To detect treponemes when yaws or pinta is suspected

### Day 2 and Onwards

#### 4 Examine and Report Cultures

- **Blood agar and MacConkey agar cultures**  
Look particularly for:  
*S. aureus*  
*S. pyogenes*  
*P. aeruginosa*  
*Proteus species*  
*E. coli*

- **Antimicrobial susceptibility tests**  
As indicated

### **Anaerobic blood agar culture and cooked meat culture**

Look for growth that could be *Clostridium perfringens*, *Bacteroides fragilis* group, or *Peptostreptococcus* species.

- *C. perfringens*: Grows rapidly in cooked meat medium with hydrogen sulphide gas production (gas bubbles in turbid medium) and reddening but no decomposition of the meat (saccharolytic reaction). On anaerobic blood agar, colonies are usually seen after 48 h incubation. Most strains produce a double zone of haemolysis (inner zone of clear haemolysis, outer zone of partial haemolysis) as shown in colour Plate 36. *C. perfringens* is described in subunit 7.18.9.
- *B. fragilis*: Grows in cooked meat medium producing decomposition with blackening of the meat (foul-smelling proteolytic reaction). On anaerobic blood agar, non-haemolytic grey colonies (Gram negative pleomorphic rods) are seen, usually within 48 hours. *B. fragilis* group is described in subunit 7.18.27.
- *Peptostreptococcus*: Grows in cooked meat medium with the production of large amounts of hydrogen sulphide gas. On anaerobic blood agar, *Peptostreptococcus* produces small non-haemolytic white colonies (Gram positive cocci) after 48 h incubation. They are resistant to metronidazole (5 µg disc).

#### **Confirming organisms are anaerobes**

When there is a mixed growth and colonies appear on the anaerobic plate that are not present on the aerobic plate, confirm that the organisms are anaerobes by subinoculating the colonies on three plates of blood agar and incubating one aerobically, one anaerobically, and the third in a carbon dioxide atmosphere (candle jar).

#### **Subculture of cooked meat medium**

Subculture the cooked meat broth after overnight incubation and when indicated also at 48 h and 72 h, when the routine plate cultures are sterile or the organisms isolated do not correspond to those seen in the original Gram smear. Subculture as described previously.

#### **Antimicrobial susceptibility testing**

Susceptibility testing may be required for *S. aureus*, enterobacteria and non-fermentative Gram negative rods. Only routinely used antibiotics should be tested. New and expensive antibiotics should only

be tested on special request or when the isolate is resistant to other drugs.

*Anaerobic pathogens*\*: Susceptibility tests should not routinely be performed on anaerobic bacteria by the disc diffusion technique. Most anaerobic infections are caused by penicillin-susceptible bacteria with the exception of infections originating in the intestinal tract or vagina. Such infections generally contain *B. fragilis* which produces *beta*-lactamase and is resistant to penicillins, ampicillins and most cephalosporins. Such infections can be treated with clindamycin, metronidazole or chloramphenicol. Aminoglycosides have no activity against anaerobes but they are often used for the treatment of patients who have mixed infections.

\*Information from: *Basic laboratory procedures in clinical bacteriology*, WHO, 2nd edition, 2003.

## 7.9 Examination of effusions

An effusion is fluid which collects in a body cavity or joint. Fluid which collects due to an inflammatory process is referred to as an exudate and that which forms due to a non-inflammatory condition is referred to as a transudate. When the effusion is an exudate, it is important to investigate whether the inflammatory process is an infective one (septic) or caused by a non-infective process, e.g. malignancy.

When the fluid is a transudate, no further microbiological testing is required.

Effusions sent to the laboratory for investigation include:

<b>Fluid</b>	<b>Origin</b>
<i>Synovial</i>	From a joint
<i>Pleural</i>	From the pleural cavity (Space between the lungs and the inner chest wall)
<i>Pericardial</i>	From the pericardial sac (Membranous sac surrounding the heart)
<i>Ascitic (peritoneal)</i>	From the peritoneal (abdominal) cavity
<i>Hydrocele</i>	Usually from the sac surrounding the testes

**Possible pathogens****SYNOVIAL FLUID**

(Synovitis and Infective arthritis)

**Gram positive**

*Staphylococcus aureus*  
*Streptococcus pyogenes*  
*Streptococcus pneumoniae*  
 Anaerobic streptococci  
 Actinomycetes

**Gram negative**

*Neisseria gonorrhoeae*  
*Neisseria meningitidis*  
*Haemophilus influenzae*  
*Brucella* species  
*Salmonella* serovars  
*Escherichia coli*  
*Pseudomonas aeruginosa*  
*Proteus*  
*Bacteroides*

Also *Mycobacterium tuberculosis*.**PLEURAL AND PERICARDIAL FLUIDS**

(Empyema and Purulent Pericarditis)

**Gram positive**

*Staphylococcus aureus*  
*Streptococcus pneumoniae*  
*Streptococcus pyogenes*  
 Actinomycetes

**Gram negative**

*Haemophilus influenzae*  
*Bacteroides*  
*Pseudomonas aeruginosa*  
*Klebsiella* strains  
 Other enterobacteria

Also *Mycobacterium tuberculosis*, fungi, and viruses especially coxsackie B virus.**ASCITIC FLUID**

(Ascites and Peritonitis)

**Gram positive**

*Enterococcus* species  
*Streptococcus pneumoniae*  
*Staphylococcus aureus*  
*Streptococcus pyogenes*  
*Streptococcus agalactiae*  
 Viridans streptococci  
*Clostridium perfringens*

**Gram negative**

*Escherichia coli*  
*Klebsiella* strains  
 Other enterobacteria  
*Pseudomonas aeruginosa*  
*Bacteroides*

Also *Mycobacterium tuberculosis* and *Candida* species.**HYDROCELE FLUID**

Occasionally *Wuchereria bancrofti* microfilariae and rarely *Brugia* species can be found in hydrocele fluid. These parasites are described in Part 1 of the book.

**Notes on causes of effusions**

- Synovitis means inflammation of the synovial membrane (lining of a joint capsule). It can be caused by bacteria, rheumatic disorder, or injury. Infective synovitis is usually secondary to bacteraemia. Patients with existing or previous joint disorders are most at risk.
- Inflammation of a joint is called arthritis. The term polyarthritis is used when many joints are affected. Arthritis can be caused by bacteria (infective arthritis), rheumatoid arthritis, gout and pseudogout, osteoarthritis

(cartilage and bone disease), spondylarthritis disorders, and filariasis. Arthritis may also precede hepatitis and accompany other viral diseases including rubella, infectious mononucleosis, and arborviral infections.

In gonococcal arthritis (usually following gonococcal bacteraemia), gonococci are difficult to find because the infection tends to remain in the synovial membrane.

Reiter's syndrome (one of the spondylarthritis disorders) affects young men. It involves inflammatory arthritis, urethritis and conjunctivitis. It is often a complication of non-specific urethritis or follows bacterial dysentery. The term reactive arthritis is used when arthritis alone develops following urethritis or bacterial dysentery.

'Tropical arthritis' is a non-specific but distinctive form of arthritis, thought to have an immunological basis perhaps in association with a virus or rickettsia.

- The term pleural effusion is used to describe a non-purulent serous effusion which sometimes forms in pneumonia, tuberculosis, malignant disease, or pulmonary infarction (embolism). It may also occur with systemic lupus erythematosus, lymphoma, rheumatoid disease, or amoebic liver abscess. The commonest cause of pericardial effusion in developing countries is pericardial tuberculosis (often HIV-related).

Empyema is used to describe a purulent pleural effusion when pus is found in the pleural space. It can occur with pneumonia, tuberculosis, infection of a haemothorax (blood in the pleural cavity), or rupture of an abscess through the diaphragm.

*Note:* The transfer of fluid (transudate) into the pleural cavity is called hydrothorax. It occurs in cardiac failure, nephrotic syndrome, severe malnutrition, and advanced cirrhosis. The collapse of a lung brought about by air in the pleural space is called pneumothorax.

- Causes of acute pericarditis other than infecting microorganisms, include myocardial infarction, rheumatic fever, malignant disease, systemic lupus erythematosus, uraemia, and trauma.
- Peritonitis means inflammation of the peritoneum, which is the serous membrane that lines the peritoneal cavity. Ascites refers to the accumulation of fluid in the peritoneal cavity causing abdominal swelling.

Peritonitis can be caused by the rupture of an abdominal organ, or as a complication of bacteraemia. Causes of ascites include tuberculosis, advanced schistosomiasis, portal hypertension, cardiac failure, and malignancy especially of the ovary, stomach, colon, and liver. A chylous ascites can develop as a complication of advanced filariasis.

**Commensals**

The small amounts of fluid which surround the joints and can be found in the pleural cavity, pericardial sac, and peritoneal cavity, have no normal microbial flora.

**COLLECTION AND TRANSPORT OF EFFUSIONS**

Collection of synovial, pleural, pericardial, peritoneal, or hydrocele fluid is carried out by a medical officer.

**In a hospital with a microbiology laboratory**

- 1 After aspiration, aseptically dispense the fluid as follows:
    - 2–3 ml into a dry, sterile, screw-cap tube or bottle to observe for clotting.
    - 9 ml into a screw-cap tube or bottle which contains 1 ml of *sterile tri*-sodium citrate (see No. 73). Mix the fluid with the anticoagulant.\*
- \**Tri*-sodium citrate prevents clotting, especially of exudates. The sterile citrated sample can be used to estimate cell numbers, protein concentration, and for microscopy and culture.
- 2 Label, and as soon as possible deliver the samples with a completed request form to the laboratory.

**In a health centre for dispatch to the laboratory**

- 1 After aspiration, aseptically dispense the fluid as follows:
  - 5 ml into a bottle of sterile thioglycollate broth (see No. 80) and mix.
  - 9 ml into a screw-cap tube or bottle which contains 1 ml of sterile *tri*-sodium citrate (see No. 73). Mix the fluid with the anticoagulant.
  - If any fluid remains, dispense into a dry, sterile, screw-cap tube or bottle, and observe for clotting.
- 2 Label each container with the date and the patient's name, number, and health centre.
- 3 Send the samples with a completed request form to reach the microbiology laboratory within a few hours. The inoculated thioglycollate broth should be kept in a warm environment, but not over 37°C or in direct sunlight.

## LABORATORY EXAMINATION OF EFFUSIONS

### Day 1

**1 Describe the appearance of the specimen**

Report:

- Colour of the effusion
- Whether it is clear, cloudy, or purulent (like pus)

- Whether it contains blood
- Whether it is clotted (sample without anti-coagulant)

**Purulent effusion:** When the specimen is pus or markedly cloudy, examine and report a Gram stained smear as soon as possible. Proceed to examine the specimen as for **pus** (described in subunit 7.8).

**Blood-stained effusion:** Culture the specimen and examine a Gram stained smear (see following text).

*Note:* When the specimen is not pus or a blood-stained effusion, transfer about 1 ml of the well-mixed citrated sample to a separate tube or bottle (need not be sterile). Use this to estimate cell numbers and protein concentration (see later text). This will avoid contaminating the remainder of the sample which may be required for culture. When the non-citrated sample does not contain clots, this should be used for the cell count and protein in preference to the citrated sample.

**2 Examine the fluid for cells**

Estimate the number of white cells in the fluid using the technique described for c.s.f. (see subunit 7.13). Report whether the cells are mainly polymorphonuclear neutrophils (pus cells) or lymphocytes. Tuberculous effusions contain mainly lymphocytes and often plasma cells (it is rare to find AFB in the fluid).

*Note:* A transudate may contain a few cells, whereas an exudate usually contains many cells.

**3 Estimate the protein**

Dilute the fluid 1 in 100 in physiological saline (0.1 ml effusion mixed with 9.9 ml saline). Estimate the total protein using the technique described for measuring total protein in c.s.f. (see subunit 6.11 in Part 1 of the book). Multiply the result by 100.

A transudate usually contains less than 30 g/l (3 g/dl) of protein whereas an exudate contains more than 30 g/l.

*Note:* An exudative pleural effusion containing lymphocytes with no organisms seen in the Gram smear is found with tuberculosis.

The following table summarizes the results of a few tests which can be performed in district laboratories to differentiate transudates from exudates.

	<b>Transudate*</b>	<b>Exudate</b>
<i>Appearance</i>	Clear, pale yellow	Purulent, cloudy, or blood-stained
<i>Clotting</i>	Does not clot	Often clots
<i>Cells</i>	Few cells	<i>Purulent:</i> Many cells, mostly neutrophils <i>Non-purulent:</i> Few or many cells, mostly lymphocytes
<i>Protein</i>	Less than 30 g/l	More than 30 g/l

\*When the sample is a transudate there is no need to examine it further.

#### 4 Culture the specimen

Culture the fluid when it contains *more than a few white cells and more than 30 g/l of protein, or when it appears blood-stained* (if pus, process it as described in subunit 7.8).

Centrifuge the citrated sample in a sterile tube at high speed for about 20 minutes to sediment the bacteria. Remove the supernatant fluid (do not discard) and resuspend the sediment. Culture the sediment as follows:

##### **Chocolate agar, blood agar and MacConkey agar**

- Inoculate the sediment on chocolate (heated blood) agar, blood agar, and MacConkey agar (see Appendix 1).
- Incubate the chocolate agar plate in a carbon dioxide enriched atmosphere at 35–37°C for up to 48 hours (see subunit 7.4), checking for growth after overnight incubation.

Incubate the blood agar plate and MacConkey agar plate aerobically at 35–37°C for up to 72 hours, examining for growth after overnight incubation.

##### ADDITIONAL

##### **Culture of specimen when tuberculosis is suspected**

Isolation, identification, and sensitivity testing of *M. tuberculosis* and other mycobacteria require the facilities of a Tuberculosis Reference Laboratory.

#### 5 Examine the specimen microscopically

##### **Gram smear**

Make a thin evenly spread smear of a purulent effusion or sediment from a centrifuged non-purulent sample (use the citrated specimen). When

dry, fix the smear with methanol for 2 minutes, and stain it by the Gram technique (see subunit 7.3.4). Examine the smear for pus cells and bacteria using the 40× and 100× objectives.

Look especially for:

- Gram positive cocci that could be *S. aureus*.
- Gram positive streptococci that could be *S. pyogenes*, or possibly enterococci.
- Gram positive diplococci or short chains that could be pneumococci.
- Gram negative rods that could be enterobacteria, *Pseudomonas*, or *H. influenzae* especially if the rods are pleomorphic.
- Gram negative intracellular diplococci that could be gonococci when the fluid is from a joint.
- Gram positive branching threads that could be actinomycetes.

##### **Ziehl-Neelsen smear**

Make a smear on a slide using several drops of sediment from the centrifuged fluid. Fix the dried smear and stain by the Ziehl-Neelsen technique as described in subunit 7.3.5. AFB are usually few and therefore a *careful* search of the smear is required. Frequently, no AFB can be found.

The appearance of *M. tuberculosis* in a Ziehl-Neelsen stained smear is shown in colour Plate 56.

##### **Fluorochrome smear**

Tubercle bacilli in effusions can rapidly be detected in a fluorochrome stained smear examined by fluorescence microscopy. The fluorescing rods can be detected using the 40× objective. The auramine staining technique is described in subunit 7.3.6.

*Note:* The commonest cause of pericardial effusion in developing countries is pericardial tuberculosis (PCTB) often linked to HIV infection.

##### ADDITIONAL

##### **Wet preparation to detect crystals when gout or pseudogout is suspected (usually in men)**

When the fluid is from a joint, transfer a drop of the sediment from the centrifuged fluid (citrated sample) to a slide, and cover with a cover glass.

Examine the preparation using the 10× and 40× objectives with the condenser iris *closed sufficiently* to give maximum contrast. Look for colourless, extracellular and intracellular (inside white cells) crystals:

- Monosodium urate crystals are needle-like in form and measure 8–10 μm in length. They can be found in effusions from patients with gout.
- Calcium pyrophosphate crystals measure up to



## Summary of Microbiological Examination of Effusions

### Day 1

#### ADDITIONAL INVESTIGATIONS

#### 1 Describe Specimen

- Describe colour and whether:
  - clear, cloudy, or purulent
  - blood stained
  - contains clots (non-citrated sample)

**IF PUS:** Examine as described in subunit 7.8

**IF BLOOD STAINED:** Proceed to step 4

#### 2 Examine for Cells

- *Estimate cell numbers*
- *Report % of cells that are:*
  - neutrophils
  - lymphocytes

#### 3 Protein

- *Report total protein in g/l*

**TRANSUDATE:** Clear unclotted fluid with few cells and protein below 30 g/l: *No need to test further.*

**EXUDATE:** When cloudy fluid with more than a few cells and protein over 30 g/l: *Proceed to steps 4 and 5*

**Note:** When the fluid contains many pus cells, examine as described for *Pus* in subunit 7.8

#### 4 Culture Specimen

- *Blood agar*  
Incubate aerobically
- *Chocolate agar*  
Incubate in CO<sub>2</sub>
- *MacConkey agar*  
Incubate aerobically
- *Culture for M. tuberculosis*  
Requires facilities of a Tuberculosis Reference Laboratory

#### 5 Examine Microscopically

- *Gram smear*  
Look for pus cells and bacteria
- *Ziehl-Neelsen*  
Look for AFB
- *Wet preparation for crystals:*  
When gout or pseudogout is suspected (*joint fluid only*)
- *Cytology smear:*  
When malignancy is suspected

### Day 2 and Onwards

#### 6 Examine and Report Cultures

- *Blood, chocolate, MacConkey agar cultures*  
Look particularly for:
 

<i>S. aureus</i>	<i>H. influenzae</i>
<i>S. pyogenes</i>	<i>Neisseria</i> species
<i>S. pneumoniae</i>	Enterobacteria
	<i>P. aeruginosa</i>
- **Antibiotic susceptibility test**  
As required

25 µm in length, are rod-shaped, and may have a line running through them. They can be found in effusions from patients with pseudogout.

**Gout:** High serum urate levels are usually found in patients with gout. Normal levels are found in patients with pseudogout.

### **Cytology smear when malignancy is suspected**

Make two thin smears of effusion sediment and while *still wet*, fix the smears in a container of 95% v/v ethanol for 20 minutes. Send the smears to a Cytology Laboratory for special staining and examination for malignant cells.

## Day 2 and Onwards

### **6 Examine and report the cultures**

#### **Chocolate agar, blood agar, and MacConkey agar cultures**

Look especially for colonies that could be:

- *Staphylococcus aureus*, see subunit 7.18.1
- *Streptococcus pyogenes*, see subunit 7.18.2
- *Streptococcus pneumoniae*, see subunit 7.18.4
- *Haemophilus influenzae*, see subunit 7.18.24
- Enterobacteria, see subunit 7.18.14.
- *Pseudomonas aeruginosa*, see subunit 7.18.20
- *Neisseria* species, see subunits 7.18.12 and 7.18.13

## 7.10 Examination of urogenital specimens

### **Possible pathogens**

#### **URETHRAL SWABS**

*Neisseria gonorrhoeae*, *Chlamydia trachomatis* (serovars D-K), and occasionally *Ureaplasma*, *Mycoplasma*, and *Trichomonas vaginalis*.

#### **CERVICAL SWABS**

**From non-puerperal women:** *Neisseria gonorrhoeae*, *Chlamydia trachomatis* (serovars D-K), *Streptococcus pyogenes*, herpes simplex virus.

**From women with puerperal sepsis or septic abortion:** *Streptococcus pyogenes*, other beta-haemolytic streptococci, *Staphylococcus aureus*, *Enterococcus* species, anaerobic cocci, *Clostridium*

*perfringens*, *Bacteroides*, *Proteus*, *Escherichia coli* and other coliforms, *Listeria monocytogenes*.

### **VAGINAL SWABS**

Vaginal discharge may be due to infection of the vagina or infection of the cervix or uterus. Pathogens causing vaginal infections include *Trichomonas vaginalis*, *Candida* species, and *Gardnerella vaginalis* with anaerobes.

### **GENITAL ULCER SPECIMENS**

*Treponema pallidum*, *Haemophilus ducreyi*, *Klebsiella (Calymmatobacterium) granulomatis*, *Chlamydia trachomatis* (serovars L1, L2, L3), herpes simplex virus.

*Note:* HIV infection is described in subunit 7.18.55.

### **Notes on pathogens**

- *N. gonorrhoeae* causes gonorrhoea. Infections in men are associated with urethral discharge and painful urination (dysuria). In symptomatic men, gonococcal urethritis can be diagnosed presumptively in up to 95% of patients by examining a Gram stained smear of pus cells (in urine sediment or urethral discharge) for intracellular Gram negative diplococci. Culture is indicated when the disease is suspected but organisms cannot be found or when treatment fails.

In women, *N. gonorrhoeae* causes cervicitis and urethritis. A presumptive diagnosis from a Gram smear has both a low sensitivity and low specificity with intracellular Gram negative diplococci being detected in only 40–60% of infected women. Many infections are asymptomatic. Cultural techniques (or specialist antigen tests, see 7.18.13) are required to diagnose urogenital gonorrhoea in women (culture is about 90% sensitive). Untreated gonococcal infections in women can lead to pelvic inflammatory disease (PID), ectopic pregnancy and other complications. Co-infection with other sexually transmitted pathogens is common. Pregnant women with gonorrhoea can pass infection to their newborn infant causing gonococcal conjunctivitis (ophthalmia neonatorum).

Antimicrobial resistance is shown by many strains of *N. gonorrhoeae*, e.g. to penicillin, tetracycline, spectinomycin, and more recently to fluoroquinolones.

- *Chlamydia trachomatis* has a high prevalence worldwide. Sexually transmitted *C. trachomatis* serovars D-K cause urogenital infections and serovars L1–L3 cause lymphogranuloma venereum (LGV). Sensitive and specific antigen tests have been developed for diagnosing chlamydial infections (see subunit 7.18.37).

In men, *C. trachomatis* is a common cause (up to 40%) of non-gonococcal urethritis (NGU). Species of *Mycoplasma* and *Ureaplasma* can also cause urethritis. Many *Chlamydia* infections are asymptomatic. In women, 60% or more of urogenital chlamydial infections are asymptomatic. The syndromic diagnosis of chlamydial infection (and also gonorrhoea) in women is difficult and often leads to overtreatment. Untreated *Chlamydia* infections are associated with serious complications including PID, ectopic pregnancy, and infertility, see also subunit 7.18.37.

In LGV, *C. trachomatis* infects lymph nodes in the

groin and surrounding tissues. A small ulcer forms at the site of infection followed by inflammation and painful swelling of the lymph glands (buboes). LGV is endemic in many tropical and subtropical countries. It is mainly diagnosed clinically.

- *T. pallidum* causes syphilis. The early and late forms of the disease are described in subunit 7.18.32. In primary and secondary syphilis, motile *T. pallidum* spirochaetes can be detected in serous fluid from lesions, examined by dark-field microscopy. *T. pallidum* cannot be isolated by cultural techniques.

About 3–5 weeks following infection (1–2 weeks after the appearance of the genital chancre), antibodies can be found in the patient's serum. Non-specific antibody tests and specific treponemal antibody tests are used to diagnose syphilis (see subunit 7.18.32). It is particularly important to screen pregnant women for infectious syphilis because *T. pallidum* can cause abortion, premature delivery, still-birth, and infection of the newborn (congenital syphilis).

- *H. ducreyi* causes chancroid, or soft sore. It is a common cause of genital ulceration in tropical countries. The ulcers are painful, shallow and tend to be ragged. Often there is also painful swelling of the inguinal lymph nodes. The organism is difficult to detect microscopically in specimens and *H. ducreyi* is not easily cultured (see subunit 7.18.25). Chancroid is becoming increasingly difficult and expensive to treat due to the resistance of *H. ducreyi* to commonly available antimicrobials.
- *K. granulomatis* causes a genital ulcerative condition called granuloma inguinale, also known as donovanosis. It is particularly prevalent in India, Papua New Guinea, Vietnam, South Africa, Zambia, Zimbabwe, Brazil and other parts of South America. Ulceration of the genitalia and surrounding skin can be extensive but unlike LGV, the lymph glands are less involved. The disease is usually diagnosed by finding intracellular Donovan bodies in Giemsa stained smears from infected tissue.
- Inflammatory sexually transmitted infections (STIs) e.g. gonorrhoea, *Chlamydia* infection, and STIs that cause ulceration, e.g. syphilis, chancroid, LGV, genital herpes, granuloma inguinale, facilitate the transmission of HIV and increase susceptibility to HIV infection. Bacterial STIs may also enhance the survival and replication of HIV in the urogenital tract. Treatment of bacterial STI has been shown to reduce the incidence of HIV transmission (42% reduction reported from a study in Tanzania following introduction of syndromic STD treatment). HIV co-infection may result in some STIs being more severe (e.g. ulceration), progressing more rapidly with earlier complications (e.g. PID, neurosyphilis), and patients responding less well to treatment with relapses.
- *T. vaginalis* is a flagellate protozoan parasite. It causes trichomoniasis with a purulent vaginal discharge in women and occasionally a nonpurulent urethral discharge in men. Most infections (about 80%) can be diagnosed microscopically.
- *C. albicans* is a yeast fungus. It is described in subunit 7.18.47. Vaginitis caused by *Candida* species produces a white odourless discharge. Vaginal candidiasis (vaginal thrush, or moniliasis) is especially common during pregnancy and may also occur when using oral contraceptives, as a complication of diabetes mellitus, or after prolonged antimicrobial treatment. It is usually diagnosed micro-

scopically. Culture is not recommended as the presence of small numbers of yeast cells is a normal finding.

- *G. vaginalis* (with anaerobes, including *Bacteroides*, *Peptostreptococcus*, *Mobiluncus*) is a common cause of bacterial vaginosis, a non-inflammatory infection of the vagina which alters the normal lactobacillary microbial flora. It produces a thin greyish-white discharge with a characteristic ammoniacal fishy odour (intensified by adding a few drops of 10% KOH) and higher than normal pH. Clue cells can be seen in Gram-stained smears.

## Commensals

**Urethral swabs:** Diphtheroids, *Acinetobacter* species, and enterobacteria. Skin commensals (see subunit 7.8) may also be present.

**Cervical swabs:** The cervix is normally sterile.

**Vaginal swabs from puberty to menopause (acid pH in vagina):** Lactobacilli, anaerobic or microaerophilic streptococci, *Clostridium* species, *Bacteroides*, *Acinetobacter* species, fusobacteria, *G. vaginalis*, mycoplasma, and small numbers of diphtheroids and yeasts.

**Vaginal swabs after menopause (alkaline pH):** Diphtheroids, micrococci, *S. epidermidis*, viridans streptococci, enterobacteria, *C. albicans* and other yeasts.

## COLLECTION AND TRANSPORT OF UROGENITAL SPECIMENS

Urogenital specimens should be collected by a medical officer or an experienced nurse.

Amies medium (see No. 11) is the most efficient medium for transporting urethral, cervical, and vaginal swabs. Specimens should be transported in a cool box.

### Collection of urethral discharge from male patients

- 1 Cleanse around the urethral opening using a swab moistened with sterile physiological saline.
- 2 Gently massage the urethra from above downwards. Using a swab, collect a sample of discharge. Make a smear of the discharge on a microscope slide by gently *rolling* the swab on the slide. This will avoid damaging pus cells which contain the bacteria.

*Note:* Very few pus cells may be present if the patient has recently passed urine. Allow 2–4 hours after urination before collecting a specimen.

- 3 When culture is indicated (see previous test), collect a sample of pus on a sterile cotton-wool swab. If possible, before inserting the swab in a container of Amies transport medium, inoculate a plate of culture medium (see later text).

- Label the specimens and deliver them to the laboratory as soon as possible. Inoculated culture plates must be incubated within 30 minutes.

#### Isolation of *N. gonorrhoeae* from urine

In acute urethritis, it is often possible to detect *N. gonorrhoeae* in pus cells passed in urine, especially the first voided urine of the day (centrifuged to sediment the pus cells).

*Note:* A rectal swab is also required from homosexual patients. A selective medium is required to isolate *N. gonorrhoeae* from a rectal specimen.

#### Collection of cervical specimens from female patients

A specimen collected from the endocervical canal is recommended for the isolation of *N. gonorrhoeae* by culture. Use a sterile vaginal speculum to examine the cervix and collect the specimen.

- Moisten the speculum with sterile warm water, and insert it into the vagina.  
*Note:* Do not lubricate the speculum with a gel that may be bactericidal.
- Cleanse the cervix using a swab moistened with sterile physiological saline.
- Pass a sterile cotton-wool swab 20–30 mm into the endocervical canal and gently rotate the swab against the endocervical wall to obtain a specimen.
- When gonorrhoea is suspected, before inserting the swab in Amies transport medium, if possible inoculate a plate of culture medium (see later text).
- Label the specimens and deliver to the laboratory as soon as possible. Inoculated culture plates must be incubated within 30 minutes.

*Note:* Women may also asymptotically carry *N. gonorrhoeae* in the rectum and can transmit the pathogen to consorts.

#### Collection of vaginal discharge to detect *T. vaginalis*, *C. albicans* and *G. vaginalis*

Two preparations are required:

- Wet preparation to detect motile T. vaginalis:* Use a sterile swab to collect a specimen from the vagina. Transfer a sample of the exudate to a microscope slide. Add a drop of physiological saline\* and mix. Cover with a cover glass. Label and deliver to the laboratory for immediate examination (see later text).

\*Use only a sterile saline solution or one that is checked daily by the laboratory to exclude contaminating motile organisms which can be mistaken for *T. vaginalis*. In tropical climates it is easy for saline solutions to become contaminated.

- Dry smear for Gram staining to detect Candida and examine for clue cells*

Although yeast cells can be seen in an unstained wet preparation, the Gram positive cells and pseudohyphae of *C. albicans* are more easily seen in a Gram stained smear. Use a sterile swab to collect a specimen from the vagina. Transfer a sample of the exudate to a microscope slide and spread it to make a *thin* smear. Allow the smear to air-dry, protected from insects and dust. Label and deliver to the laboratory with the wet preparation.

#### Appearance and pH of vaginal discharge in *Candida*, *Trichomonas*, and *Gardnerella* infections:

- T. vaginalis:* Yellow-green purulent discharge with pH over 5\*
- C. albicans:* White odourless discharge with pH below 5\*
- G. vaginalis:* Grey, offensive, smelling thin discharge with pH over 5\* (Fishy ammoniacal smell becomes more intense after adding a few drops of 10% potassium hydroxide).

\*The normal reaction of vaginal discharge (puberty to menopause) is pH 3.0–3.5. The pH can be measured using Whatman pH papers (see p. 174 in Part 1 of the book)

#### Collection of specimen to detect *T. pallidum*

To detect motile *T. pallidum* spirochaetes, a specimen must be collected before antibiotic treatment.

- Wearing protective rubber gloves, cleanse around the ulcer (chancres) using a swab moistened with physiological saline. Remove any scab which may be present.  
*Caution:* *T. pallidum* spirochaetes are highly infectious.
- Gently squeeze the lesion to obtain serous fluid. Collect a drop on a cover glass and invert it on a microscope slide.

*Note:* The cover glass and slide *must be completely clean*.

- Immediately deliver the preparation to the laboratory for examination by dark-field microscopy (see later text).

#### Collection of specimen to detect *K. granulomatis*

- Cleanse around the ulcerated area using a swab moistened with physiological saline.
- Pinch off a small piece of tissue from the edge or base of a lesion. Crush this between two microscope slides.\*

\*Technique recommended by Richens.<sup>1</sup>

- Label the slides and deliver them to the laboratory as soon as possible. When a delay is anticipated, fix the smears with absolute methanol (methyl alcohol) for 1–2 minutes.

### STIs which can be investigated in district laboratories

- *Gonorrhoea*: In symptomatic males, using Gram smear to detect Gram negative diplococci in pus cells present in urethral discharge or first voided urine.  
*Note*: Pus cells without intracellular diplococci indicate non-gonococcal urethritis.
- *Syphilis*: By detecting motile spirochaetes in serous fluid from genital chancre or skin lesion examined by dark-field microscopy. Reagin and specific treponemal antibody tests are used to diagnose syphilis serologically and screen pregnant women for infection.
- *Trichomoniasis*: By detecting motile *T. vaginalis* trophozoites in fresh wet vaginal preparations.
- *Candidiasis*: By detecting yeast cells and pseudohyphae in wet vaginal preparations or Gram stained smears.
- *G. vaginalis bacterial vaginosis*: By examining Gram stained smears of vaginal discharge (fishy odour, watery, non-inflammatory, pH over 5) for epithelial cells with adhering polymorphic bacteria (clue cells).
- *Granuloma inguinale (donovanosis)*: By detecting intracellular bipolar stained cocco-bacilli (*K. granulomatis*) in Giemsa or *RapiDiff* stained preparations of ulcer material.
- *Chlamydia*: When rapid antigen test is available (see subunit 7.18.37).

In district laboratory with culture facilities or specialist sexually transmitted diseases (STD) laboratory:

- *Gonorrhoea*: Particularly in women with suspected urogenital infection, using a selective enriched medium to isolate *N. gonorrhoeae*.

**HIV**: The laboratory diagnosis of HIV infection is described in subunit 7.18.55.

### Laboratory diagnosis of other STIs in specialist laboratories

The following STIs require expensive technologies or the facilities of a specialist laboratory for their diagnosis:

- *Urogenital Chlamydia infections (C. trachomatis serovars D–K)*  
Usually diagnosed by tissue culture or immunologically (e.g. ELISA, IFAT). PCR technologies have also been developed. Simple to perform rapid antigen tests are available (see subunit 7.18.37).
- *Chancroid*: Usually diagnosed culturally by isolating *H. ducreyi* using a selective enriched medium.
- *LGV (C. trachomatis serovars L1–L3)*: Diagnosed immunologically or by tissue culture.
- *Genital herpes (HHV-1, HHV-2) infection*: Can be diagnosed immunologically or by tissue culture.

#### Uterine curettings (scrapings) for histological examination

Immediately after collection, place the curettings in a container of formol saline fixative (Reagent No. 38). Use about ten times the volume of fixative to specimen.

Label, and send with a request form to a Histology Laboratory. Instructions regarding the packaging and mailing of pathological specimens can be found in subunit 7.1.

#### Cervical smear to be examined for malignant cells

A smear to be examined for malignant cells must be spread thinly and evenly on a slide and while *still wet*, immersed in a container of alcohol fixative (Reagent No. 8) for at least 30 minutes. Remove the smear, and allow to air-dry. Send with a request form to a Cytology Laboratory.

## LABORATORY EXAMINATION OF UROGENITAL SPECIMENS

### Day 1

#### 1 Culture the specimen

##### **Modified New York City (MNYC) or Thayer Martin medium**

- Inoculate the specimen on MNYC medium (see No. 58) or other selective enriched culture medium suitable for isolating *N. gonorrhoeae* from urogenital specimens such as Thayer Martin medium (see No. 79).

*Note:* When using MNYC medium, colonies can be tested directly for *beta*-lactamase production and utilization of carbohydrates, whereas colonies from Thayer Martin medium require subculturing first.

- With as little delay as possible, incubate the inoculated plate in a moist\* carbon dioxide enriched atmosphere (see subunit 7.4) at 35–37°C for up to 48 h, examining for growth after overnight incubation.

\*Place a damp piece of filter paper in the bottom of the candle jar.

#### ADDITIONAL

##### **Blood agar (aerobic and anaerobic), MacConkey agar, and cooked meat medium when puerperal sepsis or septic abortion is suspected**

- Inoculate the specimen on two plates of blood agar (see No. 16) and incubate one anaerobically and the other aerobically at 35–37°C overnight.
- Inoculate the specimen on MacConkey agar (see No. 54) and incubate the plate aerobically at 35–37°C overnight.
- Inoculate the specimen in cooked meat medium (see No. 27) and incubate at 35–37°C, subculturing as indicated at 24 h, 48 h and 72 h.

#### 2 Examine the specimen microscopically

##### **Gram smear**

Fix the smear with methanol (see subunit 7.3.2), and stain by the Gram technique (see subunit 7.3.4). Using the 40× and 100× objectives, examine the smear for pus cells and bacteria.

*Smear from a patient with suspected gonorrhoea*  
Look for pus cells containing Gram negative diplococci that could be *N. gonorrhoeae* (see colour Plate 43). When the pus cells have been damaged, the organisms may be seen lying outside the pus cells (extracellular).

##### **Presumptive diagnosis of gonorrhoea from a Gram smear**

When *intracellular* Gram negative diplococci are seen in a urogenital smear, a presumptive diagnosis of gonorrhoea can be made. Such a diagnosis is often possible for male patients but more difficult for female patients (see Notes on pathogens).

##### **Non-gonococcal urethritis**

*Chlamydia trachomatis* is a common cause of non-gonococcal urethritis (NGU), particularly in men (see subunit 7.18.37). A presumptive diagnosis of NGU can be made when a urethral smear contains 5 or more pus cells and no intracellular Gram negative diplococci (or more than 15 pus cells in a first voided urine specimen from a male patient).

##### *Vaginal smear from a patient with suspected bacterial vaginosis or candidiasis*

Look especially for:

- Large Gram positive yeast cells and pseudohyphae that could be *C. albicans* or other *Candida* species (see colour Plate 72).
- Clue cells, i.e. epithelial cells with adhering Gram negative short bacilli and Gram variable coccobacilli that could be *G. vaginalis* and anaerobes (see colour Plate 45). The margins of the epithelial cells are often obscured. With bacterial vaginosis, there are few or no pus cells and lactobacilli are usually absent. When clue cells predominate, report the smear as 'Clue cells seen, suggestive of bacterial vaginosis'.

##### *Smear from a patient with suspected puerperal sepsis or septic abortion*

Look especially among pus cells for:

- Large Gram positive rods with straight ends, that could be *C. perfringens* (see colour Plate 34).
- Gram positive streptococci, that could be *S. pyogenes* or other *beta*-haemolytic streptococci (see colour Plate 25).
- Gram positive cocci resembling *S. aureus* (see colour Plate 24).
- Gram negative rods, that could be *Bacteroides* or coliforms.

##### **Wet (saline) preparation to detect *T. vaginalis***

To detect motile *T. vaginalis* trophozoites, the preparation must be examined *as soon as possible* after the specimen is collected. Examine the preparation using the 10× and 40× objectives, with the condenser iris diaphragm *closed sufficiently* to give good contrast. The preparation must not be too thick.

*T. vaginalis* trophozoites are a little larger than pus cells, measuring 10–20 µm in diameter. They are round or oval in shape and move by means of an undulating membrane and flagella. There are 4 anterior flagella and a fifth flagellum forms an undulating membrane. An axostyle protrudes from the end of the organism. A trophozoite is shown in Plate 7.15 in subunit 7.12.

A careful search is often necessary to detect the flagellates among the pus cells. Movement is often slight (on the same spot) and not progressional.

**Note:** When more than 10 minutes have passed since the collection of the specimen, motility can often be increased by incubating the preparation at 35–37 °C for a few minutes (in a petri dish containing a damp piece of cotton-wool). When the organisms are not found, culture in Diamond or Feinberg medium should be considered (the organisms can be detected after 2–4 days incubation).

**Acridine orange (fluorochrome) stained preparation to detect *T. vaginalis*, yeast cells, and clue cells**

When facilities for fluorescence microscopy are available, examination of an acridine orange stained vaginal smear is recommended because *T. vaginalis*, yeast cells, and clue cells can be rapidly detected. The acridine orange fluorescence technique is described in subunit 7.3.11 and stained trichomonads are shown in colour Plate 44.

**ADDITIONAL**

**Dark-field preparation to detect motile *T. pallidum***

A preparation for the detection of motile treponemes must be examined *as soon as possible* after the specimen is collected (within 15 minutes) and before the patient has been treated (or self-treated) with antibiotics. Handle the preparation with care because the organisms are highly infectious.

Examine the preparation by dark-field microscopy using the 10× and 40× objectives (see pp. 122–123 in Part 1 of the book). A good light source is *essential*.

**Use of a dark-field stop to obtain dark-field microscopy**

To detect *T. pallidum* spirochaetes it is not necessary to use an expensive dark-field condenser. The spirochaetes can be seen using the 40× objective and therefore a dark-field stop for this objective positioned in the filter holder below the condenser of a standard microscope can be used (see pp. 122–123 in Part 1 of the book).

The preparation must be sufficiently *thin* to obtain good dark-field. Remove excess fluid by pressing a sheet of blotting paper on top of the preparation.

*T. pallidum*: Look for brightly illuminated, thin, delicate, tightly wound spirochaetes, measuring 6–15 µm long with 8–14 evenly sized coils (see colour Plate 60). They have a bending and slowly

rotating motility and may be seen lengthening and shortening. The spirochaetes of *T. pallidum* require differentiation from saprophytic genital spirochaetes. These are of variable size, thicker than *T. pallidum*, have fewer coils and a different motility.

**Giemsa stained preparation to detect *K. granulomatis***

Fix the smear(s) with methanol as described in subunit 7.3.2 and stain by the Giemsa technique (see 7.3.10) or *RapiDiff* technique. Using the 10× and 40× objectives, examine the smear for macrophage cells containing *K. granulomatis* coccobacilli, also referred to as Donovan bodies.

Use the 100× objective to examine the coccobacilli for bipolar staining. The organisms are often described as having the appearance of closed safety pins (see colour Plate 46).

**Antigen test to detect *Chlamydia*:** Details can be found in subunit 7.18.37.

**Day 2 and Onwards**

**3 Examine and report the cultures**

**MNYC and Thayer Martin cultures**

*N. gonorrhoeae* produces small raised, grey shiny colonies on MNYC medium (see colour Plate 42) and Thayer Martin medium (see colour Plate 41) after overnight incubation.

- Perform an oxidase test (see subunit 7.5.8). Neisseriae are strongly oxidase positive.
- Gram stain the colonies. *N. gonorrhoeae* appears as a Gram negative coccus.

**Note:** The accuracy of a diagnosis of gonorrhoea based on the isolation of oxidase-positive Gram negative cocci from a selective medium is as high as 99% from urethral and cervical sites. Confirmation of the diagnosis is by biochemically testing and serotyping the isolate.

- Test the colonies for *beta*-lactamase production as described at the end of subunit 7.16.

**ADDITIONAL**

**Blood agar and MacConkey agar cultures**

Look for colonies that could be:

- *Streptococcus pyogenes* or other *beta*-haemolytic streptococci, see subunit 7.18.2
- *Staphylococcus aureus*, see subunit 7.18.1
- *Clostridium perfringens*, see subunit 7.18.9
- *Proteus* species, see subunit 7.18.18
- *Enterococcus*, see subunit 7.18.5
- *Escherichia coli*, see subunit 7.18.14

## Summary of Microbiological Examination of Urogenital Specimens

### Day 1

#### 1 Culture Specimen

- **MNYC medium or Thayer-Martin medium**
  - Incubate in CO<sub>2</sub> (moist environment)

#### ADDITIONAL INVESTIGATIONS

When puerperal or septic abortion is suspected:

- **Blood agar (2 plates)**
  - Incubate aerobically
  - Incubate anaerobically
- **MacConkey agar**
  - Incubate aerobically
- **Cooked meat medium**
  - Incubate overnight. Subculture as indicated at 24 h, 48 h, 72 h.

#### 2 Examine Microscopically

- **Gram smear**
  - *Urethral*: Intracellular Gram negative diplococci
  - *Vaginal*: Yeast cells (candidiasis) Clue cells (bacterial vaginosis)
  - *Vaginal/cervical*: Pus cells and bacteria associated with puerperal sepsis and septic abortion
- **Wet preparation**  
Motile *T. vaginalis*

- **Dark-field**: When syphilis is suspected
- **Giemsa smear**:  
When *K. granulomatis* infection (donovanosis) is suspected
- **Cervical smear(s) sent to histology/cytology laboratory**:  
When malignancy is suspected

### Day 2 and Onwards

#### 3 Examine and Report Cultures

- **MNYC plate or Thayer-Martin plate**
  - Examine for *N. gonorrhoeae*

#### Colonies resembling

#### *N. gonorrhoeae*:

- Oxidase test
- Gram stain colonies
- Beta-lactamase test

- **Blood agar, MacConkey agar plates**

- Look especially for:

*S. pyogenes*  
*S. aureus*  
*C. perfringens*  
*Proteus*  
*Enterococcus*  
*E. coli*  
*Bacteroides*

- Antimicrobial susceptibility tests as required



*Note:* Other bacteria that can be isolated from cervical swabs taken from patients with puerperal sepsis or septic abortion are listed at the beginning of this subunit under 'Possible Pathogens'.

*Important:* When the plate cultures are sterile but pus cells were seen in the original Gram smear, or the organisms that have grown overnight do not resemble morphologically those seen in the Gram smear, subculture the cooked meat medium and reincubate the original blood agar plates for a further 24 hours. Organisms such as *Bacteroides* are slow-growing.

#### REFERENCE

- 1 **Richens J.** Donovanosis (granuloma inguinale). Chapter 7.7 in *Sexually transmitted infections and AIDS in the tropics* (see Further information).

#### FURTHER INFORMATION

**World Health Organization and Reproductive Health and Research.** *Sexually transmitted and other reproductive tract infections – A guide to essential practice.* WHO, Geneva, 2005.

**Van Dyck E, Meheus AZ, Piot P.** *Laboratory diagnosis of sexually transmitted diseases.* WHO, 1999. ISBN 92 4 154501 1. Available from WHO Publications, 1211 Geneva, 27-Switzerland. An excellent colour illustrated text for laboratory personnel.

**Arya UP, Hart CA.** *Sexually transmitted infections and AIDS in the tropics.* CAB1 Publishing, 1998. ISBN 085199 2625. Available from CAB1 Publishing, Wallingford, Oxon OX10 8DE, UK.

**Professor RC Ballard.** *Syndromic case management of STDs in Africa. Flow charts and treatment options.* Available from the National Reference Centre for STDs, South African Institute for Medical Research, PO Box 1038, Johannesburg, 2000, South Africa.

**HIV/AIDS:** Readers are referred to the end of subunit 7.18.55.

## 7.11 Examination of faecal specimens

### Possible pathogens

#### ■ BACTERIA

##### Gram positive

*Clostridium perfringens* types A and C  
*Clostridium difficile*  
*Bacillus cereus* (toxin)

##### Gram negative

*Shigella* species  
*Salmonella* serovars  
*Campylobacter* species  
*Yersinia enterocolitica*

*Staphylococcus aureus* (toxin)  
*Escherichia coli* (ETEC, EIEC, EPEC, VTEC)  
*Vibrio cholerae* 01, 0139  
Other *Vibrio* species  
*Aeromonas* species

Also *Mycobacterium tuberculosis*

#### ■ VIRUSES

Mainly rotaviruses and occasionally Norwalk agent, adenoviruses, astrovirus, calcivirus and coronavirus.

#### ■ PARASITES

*Entamoeba histolytica*, *Giardia lamblia*, intestinal coccidia (*Isoospora*, *Cryptosporidium*, *Cyclospora*) and other protozoan enteric pathogens are described in subunit 5.4 in Part 1 of the book. Important helminth enteric pathogens are listed on pp. 208–209 in Part 1 and described in subunit 5.5.

#### Notes on pathogens

- Acute infective diarrhoea and gastroenteritis (diarrhoea with vomiting) are major causes of ill health and premature death in developing countries in situations where water supplies are contaminated and sanitation is poor. Loss of water and electrolytes from the body can lead to severe dehydration which if untreated can be rapidly fatal in young children, especially those that are malnourished, hypoglycaemic, and generally in poor health.

Invasive organisms such as shigellae, campylobacters, some salmonellae, and *E. histolytica* are associated with dysentery (passing of blood and mucus in stools). Organisms such as rotaviruses, *V. cholerae*, and enterotoxigenic *E. coli*, cause watery (secretory) diarrhoea.

Diarrhoea may also be caused by intestinal worms, post-infective tropical malabsorption, lactase deficiency, antibiotic or other drug therapy which alters the normal intestinal flora, and from dietary causes including gluten intolerance.

Diarrhoea is also associated with HIV disease, malaria, severe malnutrition, pneumonia, hepatitis, cirrhosis of the liver, inflammation of the pancreas, tuberculosis of the intestine, colitis, previous surgery of the bowel, and malignant diseases of the intestinal tract.

- *Shigella* species: *S. dysenteriae*, *S. flexneri*, *S. boydii*, and *S. sonnei* are described in subunit 7.18.15. Dysentery caused by shigellae is referred to as bacillary dysentery or shigellosis. WHO estimates that *Shigella* species cause at least 50% of the cases of bloody diarrhoea in young children in developing countries. *S. dysenteriae* serotype 1 (Sd 1) is particularly virulent, causing endemic and epidemic dysentery with high death rates. It is highly infectious. Resistance to commonly available antimicrobials is an increasing problem, particularly in dysentery caused by Sd 1.
- *Salmonella* organisms are described in subunit 7.18.16. *S. Typhi* and *S. Paratyphi* cause enteric fever (typhoid and paratyphoid) which is endemic in many tropical and developing countries. Other salmonellae cause food-poisoning and bacteraemia.

- *Campylobacter* species are described in subunit 7.18.21. *C. jejuni* and *C. coli* are common causes of enteritis in young children in developing countries.
- *V. cholerae* serogroups (serovars) 01 and 0139 cause endemic and epidemic cholera. In recent years, epidemic cholera caused by *V. cholerae* 01 (biotype El Tor) has spread from Asia and Indonesia to many African countries, Far East, South Pacific, South America, and Mexico. Epidemic cholera caused by the serotype 0139, emerged in Bengal in 1992 and spread rapidly to other parts of India, Bangladesh, Pakistan, Thailand, Nepal, Malaysia, Burma, Saudi Arabia, and China.

The severe dehydration, vomiting, abdominal pain, and acidosis associated with cholera are due to the action of an exotoxin produced by the organism (cholera toxin) which causes water and electrolytes to flow into the bowel lumen (see subunit 7.18.19). In severe infections, typical 'rice water' stools containing many vibrios are passed continuously, necessitating urgent fluid replacement therapy to prevent collapse and death. *V. cholera* 01 El Tor is becoming increasingly resistant to commonly available antimicrobials and *V. cholerae* 0139 is also becoming resistant to some antimicrobials.

- *V. parahaemolyticus* has been reported as causing food-poisoning (through contaminated seafood) in many parts of the world including Africa, Asia, America, and Europe.
- Strains of *E. coli* recognized as causing diarrhoeal disease include enterotoxigenic *E. coli* (ETEC), enteropathogenic *E. coli* (EPEC), enteroinvasive *E. coli* (EIEC) and verotoxigenic *E. coli* (VTEC), also referred to as enterohaemorrhagic *E. coli* (EHEC). These and other diarrhoea causing *E. coli* strains are described in subunit 7.18.14.
- *Y. enterocolitica* has been reported as causing gastroenteritis in Africa, Japan, Europe, and Canada. The organism is invasive and some strains are toxigenic. Identification of the organism is described at the end of subunit 7.18.22.
- *C. perfringens* type A causes food-poisoning by secreting enterotoxin in the intestine during sporulation. Alpha-toxin is the main lethal toxin produced (see subunit 7.18.9).

*C. perfringens* type C is associated with severe jejunitis (enteritis necroticans) which is referred to in Papua New Guinea as pigbel. It is a cause of death in young children especially in Papua New Guinea (Highlands), China, the Solomon Islands, Bangladesh, and some parts of East Africa. Infection is by the ingestion of contaminated pig meat. A lethal beta-toxin is produced (see subunit 7.18.9).

- *C. difficile* causes antimicrobial associated diarrhoea and sometimes pseudomembranous colitis, a rare and occasionally fatal condition. Investigation of the disease requires the facilities of a specialist microbiology laboratory.
- *S. aureus* food-poisoning is caused by the ingestion of pre-formed toxin in contaminated food (often dairy products). Occasionally, staphylococcal enterocolitis is a complication of broad-spectrum antibiotic therapy.
- *B. cereus* food-poisoning is caused by the ingestion of pre-formed toxin usually in rice or other cereals which have been cooked and then stored for several days in warm temperatures.

- Rotavirus is the commonest cause of acute secretory diarrhoea in young children (6 months–3 years). Diarrhoea is the result of loss of extracellular fluid, due to impaired absorption. Diarrhoea and vomiting can lead to severe dehydration. Most infections are accompanied by fever.
- Persistent diarrhoea, often leading to diarrhoea-wasting syndrome ('slim disease') is common in AIDS. It is thought to be due in part to opportunistic protozoal pathogens such as *Cryptosporidium*, *Cyclospora*, *Isospora* and microsporidia. Bacterial infections associated with diarrhoea in HIV/AIDS patients include *Salmonella*, *Campylobacter*, *Shigella* and mycobacteria.

### Commensals

The normal microbial flora of the gastrointestinal tract is greatly influenced by diet. Microorganisms which may form part of this normal flora include:

- Coliform bacilli and species of *Proteus*, *Pseudomonas*, *Clostridium*, *Bacteroides*, *Enterococcus*, and lactobacilli.
- Also *Mycoplasma*, *Candida* species and a variety of protozoa and viruses.

---

### COLLECTION AND TRANSPORT OF FAECES

Faeces for microbiological examination should be collected during the acute stage of diarrhoea.

#### In a hospital with a microbiology laboratory

- 1 Give the patient a clean, dry, disinfectant-free bedpan or suitable wide-necked container in which to pass a specimen. The container need not be sterile. Ask the patient to avoid contaminating the faeces with urine.
  - 2 Transfer a portion (about a spoonful) of the specimen, especially that which contains mucus, pus, or blood, into a clean, dry, leakproof container.
- Worms and tapeworm segments:** When the specimen contains worms or tapeworm segments, transfer these to a separate container and send them to the laboratory for identification.
- 3 Write on the request form the colour of the specimen and whether it is formed, semiformed, unformed, or fluid. Report also if blood, mucus, worms, or tapeworm segments are present.
  - 4 Label the specimen and send it with a request form to reach the laboratory within 1 hour (if a delay longer than 1 hour is anticipated, collect the specimen in Cary-Blair medium, see later text).

**Rectal swabs:** Only when it is not possible to obtain faeces, collect a specimen using a cotton wool swab. Insert the swab in the rectum for about 10 seconds. Care should be taken to

avoid unnecessary contamination of the specimen with bacteria from the anal skin.

*Important:* When the specimen contains blood or amoebic dysentery is suspected, deliver it to the laboratory as soon as possible. A fresh specimen is required to demonstrate actively motile amoebae and also to isolate shigellae.

**In a health centre for transport to a microbiology laboratory**

1 Request a specimen from the patient as described previously under the hospital collection of faeces.

*Note:* Leaves, cardboard boxes, plastic bags are not suitable for the collection of faeces.

2 Transfer a portion of the faeces to a cotton wool swab. Insert the swab in a container of sterile Cary-Blair transport medium (see No. 22), breaking off the swab stick to allow the bottle top to be replaced tightly.

*Salmonella* serovars, *Shigella*, *Vibrio* and *Yersinia* species survive well in Cary-Blair medium for up to 48 hours, and *Campylobacter* for up to 6 hours.

*Note:* Merthiolate iodine formaldehyde (MIF) solution must not be used because MIF kills living organisms. MIF is used as a fixative for protozoal parasites.

*When cholera is suspected:* Transfer about 1 ml of specimen into 10 ml of sterile alkaline peptone water (see No. 10) and label. The specimen should reach the Microbiology Laboratory within 8 hours of collection.

3 Write a description of the specimen on the request form (see previous text).

*Note:* When worms or tapeworm segments are present, transfer these (using forceps) to a container of physiological saline and send to the laboratory for identification.

Instructions regarding the packaging and dispatch of specimens can be found at the end of subunit 71.

- To investigate outbreaks of dysentery (mainly shigellosis), cholera, and other acute bacterial infective diarrhoeal disease of public health concern.
- To assist the central public health laboratory in the surveillance of endemic shigellosis and salmonellosis (including susceptibility of pathogens to antimicrobials).
- To diagnose symptomatic amoebic dysentery, giardiasis and other locally important intestinal parasitic infections.

*Recommended reading:* Mundy C, Shears P. Diarrhoeal disease outbreak investigation and surveillance. Diagnostics in Africa, *Africa Health*, pp. x–xiii, September, 1994.

**Day 1**

**1 Describe the appearance of the specimen**

- Colour of the specimen.
- Whether it is formed, semiformed, unformed or fluid.
- Presence of blood, mucus or pus
- Presence of worms, e.g. *Enterobius vermicularis*, *Ascaris lumbricoides*, or tapeworm segments e.g. *Taenia* species.

**Appearance of faecal specimens in some diseases**

<i>Appearance</i>	<i>Possible Cause</i>
Unformed, containing pus and mucus mixed with blood	<ul style="list-style-type: none"> <li>● Shigellosis</li> <li>● E1EC dysentery</li> <li>● <i>Campylobacter</i> enteritis</li> </ul>
Unformed with blood and mucus (acid pH)	<ul style="list-style-type: none"> <li>● Amoebic dysentery</li> </ul>
Unformed or semiformed, often with blood and mucus	<ul style="list-style-type: none"> <li>● Schistosomiasis</li> </ul>
Bloody diarrhoea (without pus cells)	<ul style="list-style-type: none"> <li>● EHEC 0157 infection (haemorrhagic colitis)</li> </ul>
Watery stools	<ul style="list-style-type: none"> <li>● ETEC, EPEC diarrhoea</li> <li>● Cryptosporidiosis</li> <li>● Rotavirus enteritis</li> </ul>
Rice water stools with mucous flakes	<ul style="list-style-type: none"> <li>● Cholera</li> </ul>
Unformed or watery and sometimes with blood, mucus, and pus	<ul style="list-style-type: none"> <li>● <i>Salmonella</i> infection</li> </ul>
Unformed, pale coloured, frothy, unpleasant smelling stools that float on water (high fat content)	<ul style="list-style-type: none"> <li>● Giardiasis</li> <li>● Other conditions that cause malabsorption, e.g. post-infective tropical malabsorption</li> </ul>
Fluid stools (containing lactose with pH below 6)	<ul style="list-style-type: none"> <li>● Lactase deficiency</li> </ul>
Unformed or semiformed black stools (positive occult blood)	<ul style="list-style-type: none"> <li>● Melaena (gastrointestinal bleeding)</li> <li>● Hookworm disease</li> <li>● Iron therapy</li> </ul>

**LABORATORY EXAMINATION OF FAECES**

**Role of microbiological laboratory in investigating infective diarrhoeal disease**

With most patients, diarrhoea is self-limiting and can be treated with rehydration and other supportive therapy without the need for antimicrobials and microbiological investigations. The microbiological examination of faecal specimens is mainly undertaken:

**Note:** Blood can also be found in the stools of patients with haemorrhoids, ulcerative colitis, or tumours of the intestinal tract.

**Normal faeces:** Appear brown and formed or semi-formed. Infant faeces are yellow-green and semiformed.

## 2 Examine the specimen microscopically

### **Saline and eosin preparations to detect**

#### ***E. histolytica* and other parasites**

- Place a drop of fresh physiological saline on one end of a slide and a drop of eosin stain (Reagent No. 36) on the other. Using a piece of stick or wire loop, mix a small amount of *fresh* specimen (especially mucus and blood) with each drop. Cover each preparation with a cover glass.

**Important:** The eosin preparation must not be too thick otherwise it will not be possible to see amoebae or cysts.

- Examine the preparations using the 10× and 40× objectives with the condenser iris closed sufficiently to give good contrast.
- Look especially for motile *E. histolytica* trophozoites containing red cells, motile *G. lamblia* trophozoites, motile *Strongyloides* larvae, and the eggs and cysts of parasitic pathogens.

**Note:** The microscopical appearance of *E. histolytica*, *G. lamblia* and other protozoal parasites are described and illustrated in subunit 5.4 in Part 1 of the book and *Strongyloides* larvae and the eggs of helminths in subunit 5.5 in Part 1. Faecal concentration techniques are described in subunit 5.3.

### ADDITIONAL

#### **Methylene blue preparation to detect faecal leucocytes when the specimen is unformed**

- Place a drop of methylene blue stain (Reagent No. 51) on a slide. Mix a small amount of specimen with the stain, and cover with a cover glass.
- Examine the preparation for faecal leucocytes using the 40× objective with the condenser iris closed sufficiently to give good contrast.
- Report also the presence of red blood cells (RBC) as these are often present with pus cells in inflammatory invasive diarrhoeal disease (see following text).

**Faecal leucocytes (WBCs):** Look for mononuclear cells and polymorphonuclear cells (pus cells). Mononuclear cells contain a nucleus which is not

lobed whereas polymorphonuclear cells contain a nucleus which has two or more lobes (see colour Plate 6). Sometimes the cells are too damaged to be recognized (do not attempt to identify).

Pus cells are associated with bacteria that cause inflammation of the large intestine (see following text). Often red cells are also found. Mononuclear cells are found mainly in typhoid and in some parasitic infections, including amoebic dysentery.

#### **Causes of inflammatory diarrhoeal disease**

*Shigella* species  
*Campylobacter* species  
*Salmonella* (non-typhoid serovars)  
*E. histolytica*  
 EIEC

#### **Less common:**

*B. coli* (see 5.4 in Part 1)  
*Y. enterocolitica*  
*C. difficile*  
*C. perfringens* (causing pigbel)  
*Aeromonas* species

#### **Basic fuchsin smear to detect campylobacters**

Prepare when the specimen is unformed and, or, contains mucus, pus, or blood and is from a child under 2 y.

- Make a *thin* smear of the specimen on a slide. When dry, *gently* heat-fix. Stain by covering the smear with 10 g/l basic fuchsin\* for 10–20 seconds. Wash well with water and allow to air-dry.

\*Dissolve 1 g basic fuchsin in 100 ml of water, and filter.

- Examine the smear for campylobacters using the 100× oil immersion objective.

**Campylobacter organisms:** Look for abundant small, delicate, spiral curved bacteria (often likened to gull wings), S-shapes, and short spirochaetal forms as shown in colour Plate 15.

**Note:** Examination of stained faecal smears for campylobacters has been shown to be a sensitive method for the presumptive diagnosis of campylobacter enteritis. Culture of *Campylobacter* species is described in subunit 7.18.21.

#### **Motility test and Gram stained smear when cholera is suspected**

Examine an alkaline peptone water culture (sample from the surface of the culture) for vibrios showing a rapid and darting motility. The preparation is best examined using dark-field microscopy but the vibrios can also be seen using transmitted light. Techniques for detecting motile bacteria are described in subunit 7.3. Experience is required to identify the characteristic motility of *V. cholerae*. Examine also a Gram-stained smear of the culture

for Gram negative vibrios (use 1 in 10 dilution of carbol fuchsin as the counterstain instead of neutral red), see colour plate 7.

#### Use of *V. cholerae* 0 (group 1) antiserum to immobilize vibrios

Cholera can be caused by serogroups 01 and 0139 and therefore a negative test cannot exclude cholera when *V. cholerae* 0 group 1 antiserum only is used in an immobilization test. Some workers have also found the test to be unreliable because the vibrios can be immobilized by preservative in the antiserum.

**Antigen detection:** A rapid, simple to perform dipstick test to detect *V. cholerae* 01 and 0139 in faeces has been developed. The test is described in subunit 7.18.19.

### 3 Culture the specimen

When the specimen is formed or semiformed, make a thick suspension of it in about 1 ml of sterile peptone water.

#### **Xylose lysine deoxycholate (XLD) agar**

- Inoculate a loopful of fresh emulsified faeces or a fluid specimen on XLD agar (see No. 90).
- Incubate the XLD agar plate aerobically at 35–37°C overnight.

**XLD agar:** This selective medium is recommended for the isolation of salmonellae and particularly shigellae from faecal specimens. It contains the indicator phenol red which is red at an alkaline pH (medium is pH 7.4) and yellow at an acid pH.

Shigellae form pink-red colonies because they do not ferment xylose, lactose, or sucrose (except some *S. sonnei* strains).

Salmonellae also form pink-red colonies even though they ferment xylose with acid production. This is because they break down the amino acid lysine which gives an alkaline reaction. Hydrogen sulphide (H<sub>2</sub>S) producing salmonellae form red colonies with black centres.

Some *Proteus* strains and *Edwardsiella* species form pink-red colonies with black centres. *Escherichia coli*, *Enterobacter* species, and some other enterobacteria produce yellow colonies due to carbohydrate fermentation.

**Note:** Some workers also recommend the use of a less selective medium such as MacConkey agar in addition to XLD agar.

#### ADDITIONAL

#### **Alkaline peptone water and TCBS agar when cholera is suspected**

- Inoculate several loopfuls of specimen in alkaline (pH 8.6) peptone water (see No. 10), and incubate at 35–37°C for 5–8 hours.

**Note:** Prior enrichment in alkaline peptone water is not necessary if the specimen is likely to contain large numbers of vibrios (e.g. in acute cholera). Alkaline peptone water is a useful transport medium for *V. cholerae*.

- Subculture several loopfuls of the peptone water culture (taken from the surface) on thiosulphate citrate bile-salt sucrose (TCBS) agar (see No. 81). Incubate aerobically at 35–37°C overnight.

**TCBS medium:** The choice of TCBS agar as a primary selective medium for isolating *V. cholerae* and other *Vibrio* species is discussed in subunit 7.18.19.

#### **Sorbitol MacConkey agar, when an outbreak of *E. coli* 0157 is suspected**

- Inoculate a loopful of specimen on sorbitol MacConkey agar (see No. 77).
- Incubate the plate aerobically at 35–37°C overnight.

#### **Sorbitol MacConkey agar**

This MacConkey medium contains the carbohydrate sorbitol instead of lactose. *E. coli* 0157 produces colourless colonies on the medium because it does not ferment sorbitol. Most other *E. coli* strains and other enterobacteria ferment sorbitol, producing pink colonies. Sorbitol MacConkey agar is therefore a useful way of screening for *E. coli* 0157 (reported as having a specificity of 85% and sensitivity of 100%).

#### **Culture of Campylobacter**

This is described in subunit 7.18.21.

#### **Investigation of food-poisoning caused by clostridia, *S. aureus* and *B. cereus***

For the isolation of pathogens and, or, toxins that cause clostridial, staphylococcal and *Bacillus cereus* food-poisoning, readers are referred to Collins and Lyne's *Microbiological Methods*, and other microbiology textbooks (see Recommended Books listed on p. 379).

## Day 2 and Onwards

### 4 Examine and report the cultures

#### **XLD agar culture**

Look for colonies that could be *Shigella* or *Salmonella*. *Shigella* and H<sub>2</sub>S negative strains of *Salmonella* produce 1–2 mm diameter red colonies on XLD agar. Red colonies with black centres are produced by H<sub>2</sub>S positive salmonellae, e.g. strains of *S. Typhimurium*.

*Proteus*, *Providencia* and *Pseudomonas* organisms may also produce red colonies on XLD agar. Some *Proteus* strains are also H<sub>2</sub>S producing and form red colonies with black centres.

**Note:** *Salmonella* and *Shigella* XLD cultures are shown in colour Plates 11 and 12.

**On MacConkey agar,** shigellae, and salmonellae and other non-lactose fermenting organisms, produce colourless colonies. *E. coli* and other lactose-fermenting organisms produce pink colonies.

### Identification of suspect *Salmonella* and *Shigella* isolates

Perform a urease test using urea broth or a Rosco urease identification tablet as described in subunit 7.5.9.

A positive urease test within 2–4 h indicates that the organism is probably *Proteus*. No further tests are required.

When the urease test is *negative* at 4 hours, proceed as follows:

- 1 Perform indole and lysine decarboxylase (LDC) tests as described in subunit 7.5.6.
- 2 Inoculate a tube of Kligler iron agar (see No. 45). Use a sterile straight wire, stab first the butt and then streak the slope. Close the tube with a loose-fitting cap and incubate at 35–37°C overnight.

### Results

**LDC** *Shigella* are LDC negative.  
*Salmonella* serovars are LDC positive except *S. Paratyphi* A which is LDC negative.

**Indole** *S. sonnei* is indole negative. Other shigellae give variable indole reactions (see subunit 7.18.15)  
*Salmonella* serovars are indole negative.

**KIA** *Salmonella* and *Shigella* organisms produce a pink-red slope and yellow butt. Many salmonellae also produce blackening due to hydrogen sulphide production and cracks in the medium due to gas production from glucose fermentation. *Salmonella* Typhi produces only a small amount of blackening and no cracks in the medium. KIA reactions are shown in colour Plate 13.

*Note:* The features of *Salmonella* serovars are described in subunit 7.18.16 and *Shigella* species in subunit 7.18.15.

### Serological identification of salmonellae and shigellae

- 1 Test serologically any isolate giving reactions suggestive of *Salmonella* or *Shigella*, using a slide technique.

**Note:** The antisera required to identify *Shigella* species are listed in subunit 7.18.15 and *Salmonella* serovars in subunit 7.18.16. When antisera are not available, send

isolates of the organism (on nutrient agar) to the Regional Public Health Laboratory for serotyping.

- 2 Emulsify a small amount of growth from the KIA culture in a loopful of physiological saline on a slide. Mix by tilting the slide backwards and forwards for about 30 seconds. Examine for agglutination against a dark background. When there is agglutination (autoagglutination), the strain is unsuitable for serological testing. A nutrient agar culture should be sent for further testing to a Reference Laboratory.
- 3 When there is no autoagglutination add one loopful of test antiserum, and mix. Examine for agglutination. A positive test will show strong clear agglutination within 1 minute.

**Interference by K antigens:** Surface (K) antigens possessed by some salmonellae and shigellae, for example the Vi antigen of *Salmonella* Typhi, can interfere with O antigen testing. When this is suspected (e.g. positive Vi agglutination, but no agglutination with O Group 1 antiserum), heat a saline suspension of the organism in a container of boiling water for 30 minutes. This will inactivate the surface antigens and enable O antigen testing to be performed. Retest the heat-treated organisms when the suspension has cooled.

### TCBS agar culture

*V. cholerae* is sucrose fermenting and therefore produces yellow 2–3 mm in diameter shiny colonies on TCBS agar with a yellow colour in the medium, as shown in colour Plate 8.

*Note:* With prolonged incubation (48 h or more) the colonies may become green.

*V. fluvialis* is also sucrose fermenting and may occasionally be isolated as a pathogen from faecal specimens (see subunit 7.18.19).

*Vibrio parahaemolyticus* is non-sucrose fermenting and therefore produces green-blue 2–3 mm in diameter colonies on TCBS agar, as shown in colour Plate 10. *V. mimicus* also produces non-sucrose fermenting green-blue colonies and is sometimes isolated (see subunit 7.18.19).

### Selectivity of TCBS

Very occasionally, *Aeromonas* species and enterococci produce small yellow colonies on TCBS agar (see colour Plate 9). *Proteus* strains may produce yellow or yellow-green colonies with black centres, and some *Pseudomonas* strains form small green colonies.

### Identification of a suspect *V. cholerae* isolate

- 1 Examine a Gram stained smear of the culture for Gram negative vibrios as shown in colour Plate 7. The organisms may appear less curved after culture.

**Chart 7.8** Tests used to identify presumptively shigellae and salmonellae

KIA Medium Reactions							
	Motility	Indole	LDC	Slope	Butt	Black (H <sub>2</sub> S)	Cracks (Gas)
<b>SHIGELLAE</b>							
<i>Shigella dysenteriae</i>	–	d	–	R	Y	–	–
<i>Shigella flexneri</i>	–	d	–	R	Y	–	– <sup>1</sup>
<i>Shigella boydii</i>	–	d	–	R	Y	–	– <sup>2</sup>
<i>Shigella sonnei</i>	–	–	–	R	Y	–	–
<b>SALMONELLAE</b>							
<i>Salmonella</i> Paratyphi A	+	–	–	R	Y	– <sup>3</sup>	+
<i>Salmonella</i> Paratyphi B	+	–	+	R	Y	+	+
<i>Salmonella</i> Paratyphi C	+	–	+	R	Y	+ <sup>4</sup>	+
<i>Salmonella</i> Typhi	+	–	+	R	Y	+ Weak	–
Other <i>Salmonella</i> serovars	+ <sup>5</sup>	–	+	R	Y	+ <sup>6</sup>	d

Key: KIA = Kligler iron agar, LDC = Lysine decarboxylase, d = different strains give different results, R = Red-pink (alkaline reaction), Y = Yellow (acid reaction).

#### Notes

1 Some strains of serotype 6 produce gas. 2 Serotypes 13 and 14 produce gas. 3 About 12% of strains produce H<sub>2</sub>S weakly. 4 A minority of strains do not produce H<sub>2</sub>S. 5 *Salmonella* Pullorum and *Salmonella* Gallinarum are non-motile. 6 A minority of strains do not produce H<sub>2</sub>S.

The reactions of salmonellae and shigellae compared with other enterobacteria are summarized in Chart 7.10 in subunit 7.18.15.

- Subculture the organism on a slope of nutrient agar (use a heavy inoculum), and incubate for 4–6 hours.
- Perform an oxidase test on the nutrient agar culture (see subunit 7.5.8).

**Note:** It is not possible to perform an oxidase test directly from a TCBS culture because the acid produced by the sucrose fermenting colonies will inhibit the oxidase reaction. Subculturing to nutrient agar is also required to perform serological tests reliably.

**Note:** When the oxidase test is positive, presume the isolate to be *V. cholerae*. It must be tested serologically (using nutrient agar culture) to confirm the organism is *V. cholerae* 01 or 0139.

#### Antisera to identify *V. cholerae* 01 and 0139

In the investigation of a cholera epidemic, a prompt diagnosis is required. With the rapid spread of *V. cholerae* 0139, many laboratories will need to use both *V. cholerae* 01 antiserum and *V. cholerae* 0139 (Bengal) antiserum to identify isolates. There is no need to differentiate between classical and El Tor biovars (most outbreaks of *V. cholerae* 01 are caused by the El Tor biovar), nor between Ogawa and Inaba serotypes (see subunit 7.18.19).

**Note:** Biochemical tests that can be used to differentiate *V. cholerae* from other *Vibrio* species are described in subunit 7.18.19.

## Summary of the Microbiological Examination of Faecal Specimens

### Day 1

#### ADDITIONAL INVESTIGATIONS

#### 1 Describe Specimen

- **Report**
  - Colour
  - Whether formed, semi-formed, unformed, fluid
  - Presence of blood, mucus, pus
  - Presence of worms

#### 2 Examine Microscopically

- **Saline and eosin:**  
To detect parasites
- **Methylene blue:**  
To detect WBCs when the specimen is unformed
- **Basic fuchsin smear:**  
When *Campylobacter* enteritis is suspected
- **Motility test and Gram smear:**  
From alkaline peptone water culture when cholera is suspected

#### 3 Culture Specimen

- **XLD agar**  
Incubate aerobically
- **MacConkey agar**  
Incubate aerobically
- **Alkaline peptone water and TCBS agar:**  
When cholera is suspected
- **Sorbitol MacConkey agar:**  
When infection with VTEC 0157 is suspected

### Day 2 and Onwards

#### ■ Examine and Report Cultures

- **XLD and MacConkey agar cultures**  
Look for: *Salmonella* and *Shigella*:
  - Exclude *Proteus* using urease test
  - Identify presumptively:
    - LDC and indole
    - Motility
    - KIA
  - Identify serologically
  - Perform susceptibility testing on *Shigella* isolates
- **Examine TCBS culture**
  - Look for colonies that could be *V. cholerae*
  - Gram stain colonies
  - Subculture on nutrient agar
  - Perform oxidase test
  - Identify serologically
- **Examine sorbitol MacConkey agar culture**
  - Look for colourless colonies that could be VTEC 0157
  - Perform 0157 latex agglutination test



**Sorbitol MacConkey agar culture**

*E. coli* 0157 strains are non-sorbitol fermenting, producing colourless colonies on sorbitol MacConkey agar. Most other *E. coli* strains ferment sorbitol, forming pink colonies.

Isolates suspected of being *E. coli* 0157 require O serotyping using a rapid latex agglutination test or other technique to detect 0157 antigen. When the test is positive, suspect the organism to be verotoxigenic *E. coli* 0157 strain if investigating an outbreak of haemorrhagic colitis (bloody diarrhoea without pus) often in association with haemolytic uraemic syndrome (HUS). Confirmation that the organism is a vero-toxin (VT) producing *E. coli* 0157 strain requires the facilities of a Microbiology Reference Laboratory able to test for VT.

**Availability of latex agglutination test kits to detect *E. coli* 0157 antigen**

Manufacturers and suppliers of latex agglutination tests to detect *E. coli* 0157 antigen include Pro-lab Diagnostics: 50 test kit, code PL070, and Oxoid: 100 test kit, code DR0620M. The shelf-life of most test kits is about 18 months. Details of manufacturers can be found in Appendix 11.

*Note:* Further information on *E. coli* 0157 can be found in subunit 7.18.14.

## 7.12 Examination of urine

**Possible pathogens**

## ■ BACTERIA

**Gram positive**

*Staphylococcus saprophyticus*  
Haemolytic streptococci

**Gram negative**

*Escherichia coli*  
*Proteus* species  
*Pseudomonas aeruginosa*  
*Klebsiella* strains  
\**Salmonella* Typhi  
\**Salmonella* Paratyphi  
\**Neisseria gonorrhoeae*

\*These species are not primarily pathogens of the urinary tract, but may be found in urine.

Also *Mycobacterium tuberculosis*, *Leptospira interrogans*, *Chlamydia*, *Mycoplasma* and *Candida* species.

## ■ PARASITES

*Schistosoma haematobium*, *Trichomonas vaginalis*, and occasionally *Enterobius vermicularis*, *Wuchereria bancrofti* and *Onchocerca volvulus*.

Finding intestinal parasites in urine indicates faecal contamination.

*Note:* *S. haematobium*, *E. vermicularis*, *W. bancrofti* and *O. volvulus* are described in Part 1 of the book and *T. vaginalis* in subunit 7.10.

**Notes on pathogens**

- The presence of bacteria in urine is called bacteriuria. It is usually regarded as significant when the urine contains  $10^5$  organisms or more per ml ( $10^8/1$ ) in pure culture. Infection of the bladder is called cystitis. It causes frequency, dysuria (pain on passing urine), suprapubic pain, sometimes haematuria and usually pyuria (increased number of pus cells in urine). The term acute urethral syndrome, (dysuria-pyuria) is used to describe acute cystitis accompanied by pyuria but in which no bacteria are detected by routine culture.

Infection of the kidney is called pyelonephritis. It causes loin pain, pyuria, rigors, fever, and often bacteraemia. Risk of infection is increased when there is urine retention due to the bladder not emptying completely, or when urinary flow is obstructed due to renal stones, urinary schistosomiasis, enlarged prostate (commonest cause of recurring UTI in men), or tumour. Persistent or recurrent urinary tract infection (UTI) can lead to renal failure.

- Urinary tract infections occur more frequently in women than men due to the shortness of the female urethra. Symptomatic and asymptomatic UTI is common in pregnancy. Undetected, untreated, asymptomatic bacteriuria can lead to pyelonephritis later in pregnancy or during puerperium.
- *E. coli* is the commonest urinary pathogen causing 60–90% of infections. Some strains are more invasive, e.g. capsulated strains are able to resist phagocytosis, other strains are more adhesive.
- UTIs caused by *Pseudomonas*, *Proteus*, *Klebsiella* species and *S. aureus*, are associated with hospital-acquired infections, often following catheterization or gynaecological surgery. *Proteus* infections are also associated with renal stones.
- *S. saprophyticus* infections are usually found in sexually active young women.
- Infection of the anterior urinary tract (urethritis) is mainly caused by *N. gonorrhoeae* (especially in men), staphylococci, streptococci, and chlamydiae.
- *Candida* urinary infection is usually found in diabetic patients and those with immunosuppression.
- *M. tuberculosis* is usually carried in the blood to the kidney from another site of infection. It is often suspected in a patient with chronic fever when there is pyuria but the routine culture is sterile.

Pyuria with a negative urine culture may also be found when there is infection with *Chlamydia trachomatis*, *Ureaplasma*, or *N. gonorrhoeae*, or when a patient has taken antimicrobials.

- *S. Typhi* and *S. Paratyphi* can be found in the urine of about 25% of patients with enteric fever from the third week of infection. Excretion of bacteria is not associated with pyuria.

Typhoid carriers may excrete *S. Typhi* in their urine for many years. Carriers are common in schistosomiasis endemic areas.

### Commensals

The bladder and urinary tract are normally sterile. The urethra however may contain a few commensals and also the perineum (wide variety of Gram positive and Gram negative organisms) which can contaminate urine when it is being collected.

With female patients, the urine may become contaminated with organisms from the vagina. Vaginal contamination is often indicated by the presence of epithelial cells (moderate to many) and a mixed bacterial flora.

Most urine specimens will contain fewer than  $10^4$  contaminating organisms per ml providing the urine has been collected with care to minimize contamination and the specimen is examined soon after collection before the commensals have had time to multiply significantly.

### COLLECTION AND TRANSPORT OF URINE

Whenever possible, the first urine passed by the patient at the beginning of the day should be sent for examination. This specimen is the most concentrated and therefore the most suitable for culture, microscopy, and biochemical analysis.

Midstream urine (MSU) for microbiological examination is collected as follows:

#### **In a hospital with a microbiology laboratory**

- 1 Give the patient a sterile, dry, wide-necked, leak-proof container and request a 10–20 ml specimen.

*Important:* Explain to the patient the need to collect the urine with as little contamination as possible, i.e. a 'clean-catch' specimen.

**Female patients:** Wash the hands. Cleanse the area around the urethral opening with clean water, dry the area with a sterile gauze pad, and collect the urine with the labia held apart.

**Male patients:** Wash the hands before collecting a specimen (middle of the urine flow).

*Note:* When a patient is in renal failure or a young child, it may not be possible to obtain more than a few millilitres of urine.

- 2 Label the container with the date, the name and number of the patient, and the *time* of collection. *As soon as possible*, deliver the specimen with a request form to the laboratory.

When immediate delivery to the laboratory is not possible, refrigerate the urine at 4–6 °C. When a delay in delivery of more than 2 hours is anticipated, add boric acid preservative to the urine

(see 'Collection in a health centre'). Specimens containing boric acid need not be refrigerated.

#### **Deterioration of urine**

The following changes occur when unpreserved urine is left at room temperature:

- Any bacteria in the urine will multiply so that the bacterial count will be unreliable. When the organisms are urease-producing, the ammonia released will increase the pH of the specimen which will result in the destruction of cells and casts. Bacteria will also break down any glucose which may be present.
- When white cells, red cells, and casts are present, these will begin to lyse especially in a concentrated specimen.
- The concentration of protein in the urine will be altered. When bilirubin is present this may be oxidized to biliverdin which will not be detected. Likewise, urobilinogen will not be detected because it will be oxidized to urobilin.

#### **In a health centre for dispatch to a microbiology laboratory**

- 1 Give the patient a sterile, dry, leak-proof container with instructions on how to collect a clean-catch MSU (see previous text).
- 2 Add a measured amount of boric acid powder (0.1 g/10 ml of urine) to preserve the specimen, and mix well.

*Note:* A simple way of measuring routinely the boric acid is to use a small narrow tube (precipitin tube), marked to hold 0.2 g of the chemical (sufficient for 20 ml urine). This 'measuring-tube' can be kept attached to the neck of the boric acid container by an elastic band.

#### **Boric acid preservative**

At a concentration of 10 g/l (1% w/v), bacteria remain viable without multiplying. White cells, red cells, and casts are also well preserved, and there is no interference in the measurement of urinary protein and glucose. Boric acid has been shown to be inhibitory to some enterococci and *Pseudomonas* strains.

*Important:* Urine for culture must not be preserved with a bactericidal chemical such as thymol, bleach, hydrochloric acid, acetic acid, or chloroform.

- 3 Label the container, and send the urine with a request form to reach the Microbiology Laboratory within 48 hours. When possible examine the urine microscopically in the Health Centre for bacteria and pus cells to screen for urinary infection.

#### **Dipslides**

Commercially prepared *Dipslides* consist of media-coated disposable plastic slide-spoons. Inoculation is by immersing the slide-spoon in a container of urine or by allowing a flow of urine to pass over the medium. They are used to avoid the overgrowth of commensals when there is likely to be a delay in a specimen reaching the laboratory. Dipslides, however, are

expensive, have a shelf-life of only about 4 months from manufacture, and it may not be possible to separate a true pathogen for susceptibility testing when contaminating organisms are also present but not obvious in a heavy growth. Preserving urines using boric acid (see previous text) is less expensive and also enables a urine to be examined microscopically.

### **Collection of urine when renal tuberculosis is suspected**

The specimen will need to be tested in a Tuberculosis Reference Laboratory. The testing laboratory should provide written instructions on the collection of urine for the isolation of *M. tuberculosis*.

## LABORATORY EXAMINATION OF URINE

### Day 1

#### 1 Describe the appearance of the specimen

Report:

- Colour of specimen
- Whether it is clear or cloudy (turbid)

<b>Appearance</b>	<b>Possible Cause</b>
Cloudy Urine usually has an unpleasant smell and contains WBCs	<ul style="list-style-type: none"> <li>● Bacterial urinary infection</li> </ul>
Red and cloudy Due to red cells	<ul style="list-style-type: none"> <li>● Urinary schistosomiasis</li> <li>● Bacterial infection</li> </ul>
Brown and cloudy Due to haemoglobin	<ul style="list-style-type: none"> <li>● Malaria haemoglobinuria</li> <li>● Other conditions that cause intravascular haemolysis</li> </ul>
Yellow-brown, or green-brown Due to bilirubin	<ul style="list-style-type: none"> <li>● Acute viral hepatitis</li> <li>● Obstructive jaundice</li> </ul>
Yellow-orange Due to urobilin, i.e. oxidized urobilinogen	<ul style="list-style-type: none"> <li>● Haemolysis</li> <li>● Hepatocellular jaundice</li> </ul>
Milky-white Due to chyle	<ul style="list-style-type: none"> <li>● Bancroftian filariasis</li> </ul>

*Note:* Other changes in the colour of urine can be caused by the ingestion of certain foods, herbs, and drugs especially vitamins.

Normal *freshly* passed urine is clear and pale yellow to yellow depending on concentration (see also urine biochemical tests, described in subunit 6.11 in Part I of the book).

*Note:* When left to stand, a cloudiness may develop due to the precipitation of urates in an acid urine or phosphates and carbonates in an alkaline urine. Urates may give the urine a pink-orange colour.

#### 2 Examine the specimens microscopically

Urine is examined microscopically as a wet preparation to detect:

- significant pyuria, i.e. WBCs in excess of 10 cells/ $\mu\text{l}$  ( $10^6/1$ ) of urine
- red cells
- casts
- yeast cells
- *T. vaginalis* motile trophozoites
- *S. haematobium* eggs
- bacteria (providing the urine is freshly collected)

To diagnose urinary schistosomiasis microscopically, and to detect casts when few in number, examination of a sediment from centrifuged urine is required to concentrate the eggs and casts. Because concentration techniques are not easily standardized it is difficult to estimate white cell numbers to establish whether there is significant pyuria (pus cell numbers above normal). In practice most district laboratories report the numbers of white cells in centrifuged urine as few, moderate number, or many (see later text) with only moderate numbers and many being regarded as significant when investigating UTI. Examination of a Gram stained smear provides additional useful information (see later text).

#### Value of examining uncentrifuged urine

Detecting bacteria in uncentrifuged (fresh) urine indicates urinary infection, i.e. bacteriuria in excess of  $10^4/\text{ml}$ . Pyuria can be quantified by counting WBCs or estimating numbers by examining a drop of urine on a slide (1 WBC per low power field corresponds to 3 cells per  $\mu\text{l}$ ). Alternatively, when an inverted microscope is available, 60  $\mu\text{l}$  of urine can be examined in a flat-bottom well of a microtitration plate and cell numbers calculated using a simple formula. Most laboratories that examine large numbers of urine specimens use an inverted microscope technique to screen for significant pyuria and whether a specimen requires culturing.

*Note:* To examine a drop of unstained uncentrifuged urine on a microscope slide by transmitted light microscopy, requires careful focussing and adequate closing of the condenser iris to provide good contrast.

### Preparation and examination of a wet preparation

- 1 Aseptically transfer about 10 ml of well mixed urine to a labelled conical tube.
- 2 Centrifuge at 500–1000 g for 5 minutes. Pour the supernatant fluid (by completely inverting the tube) into a second container not the original one. This can be used for biochemical tests to avoid contaminating the original urine which may need to be cultured (depending on the findings of the microscopical examination).
- 3 Remix the sediment by tapping the bottom of the tube. Transfer one drop of the *well-mixed* sediment to a slide and cover with cover glass.  
*Note:* Do not discard the remaining sediment because this may be needed to prepare a Gram smear if WBCs and, or, bacteria are seen in the wet preparation.
- 4 Examine the preparation microscopically using the 10× and 40× objective with the condenser iris *closed sufficiently* to give good contrast.

Report the following:

**Bacteria** (report only when the urine is *freshly* passed): Usually seen as rods, but sometimes cocci or streptococci (see Plate 7.13). Bacteriuria is usually accompanied by pyuria (pus cells in urine).

*Note:* In a urinary infection, protein and nitrite are often found in the urine (see later text). With *E. coli* infections, the urine is markedly acid. An alkaline urine is found with *Proteus* infections.

**White cells (pus cells):** These are round, 10–15 μm in diameter, cells that contain granules as shown in Plate 7.11. In urinary infections they are often found in clumps. In urine sediments, white blood cells (WBC) are usually reported as:

*Few:* Up to 10 WBCs/HPF (high power field, i.e. using 40× objective)

*Moderate number:* 11–40/HPF

*Many:* More than 40 WBC/HPF

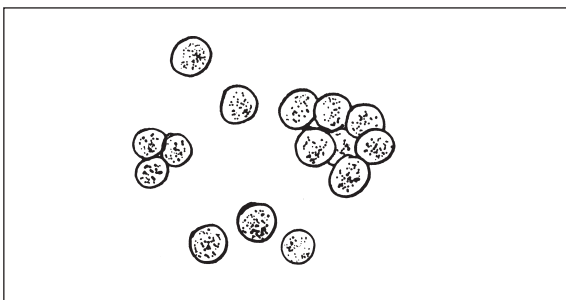

Fig 7.14 Pus cells, see also Plate 7.11

*Note:* A few pus cells are normally excreted in urine. Pyuria is usually regarded as significant when moderate or many pus cells are present, i.e. more than 10 WBC/μl (see previous text). Bacteriuria without pyuria may occur in diabetes, enteric fever, bacterial endocarditis, or when the urine contains many contaminating organisms.

Pyuria with a sterile routine culture may be found with renal tuberculosis, gonococcal urethritis, *C. trachomatis* infection, and leptospirosis, or when a patient with urinary infection has been treated with antimicrobials.

**Red cells:** These are smaller and more refractile than white cells (see Plate 7.11). They have a definite outline and contain *no* granules. When the urine is isotonic, they have a ringed appearance as shown in Fig. 7.15. They are usually reported as few, moderate or many in number per high power field.

*Note:* When the urine is hypertonic, i.e. more concentrated than the fluid inside the red cells, fluid will be drawn out of the cells and they will appear smaller than normal and often crenated (spiky) as shown in Fig. 7.15.

When haematuria is due to glomerulonephritis, the red cells often vary in size and shape (dysmorphic).

In sickle cell disease, sickled red cells can sometimes be seen in the urine.

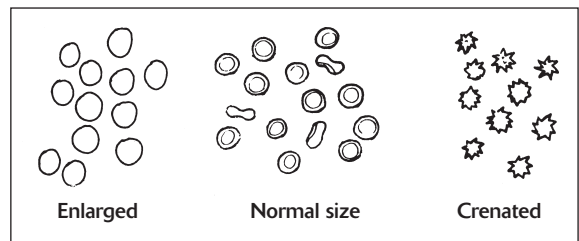

Fig 7.15 Red cells, see also Plate 7.11

Haematuria (red cells in urine) may be found in urinary schistosomiasis (usually with proteinuria), bacterial infections, acute glomerulonephritis (inflammation of the glomeruli of the kidneys), sickle cell disease, leptospirosis, infective endocarditis, calculi (stones) in the urinary tract, malignancy of the urinary tract, and haemorrhagic conditions.

*Note:* The finding of red cells in the urine of women may be due to menstruation.

**Casts:** These can usually be seen with the 10× objective provided the condenser iris is *closed sufficiently* to give good contrast. They consist of solidified protein and are cylindrical in shape because they are formed in the kidney tubules. The following casts can be found in urine:

- Hyaline casts, which are colourless and empty (see Plate 7.12). They are associated with damage to the glomerular filter membrane. A few may be

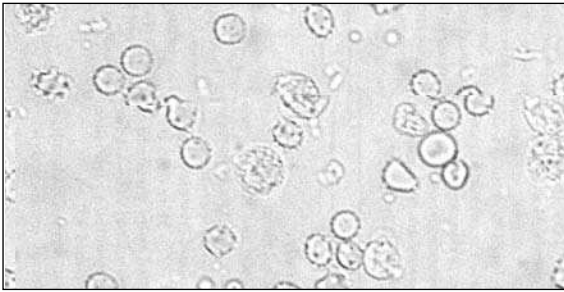

Plate 7.11 Urine sediment showing pus cells (larger granulated cells) and red cells as seen with the 40× objective. Courtesy of Professor DK Banerjee.

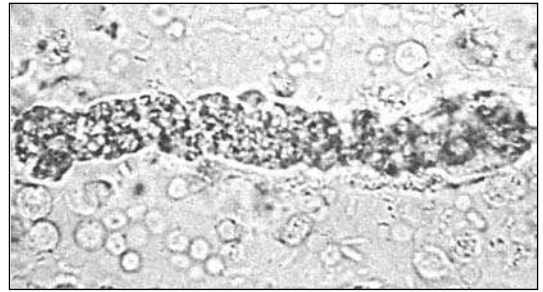

Plate 7.13 Large cellular cast, pus cells, red cells, and bacteria (bacilli in background) in urine sediment as seen with the 40× objective.

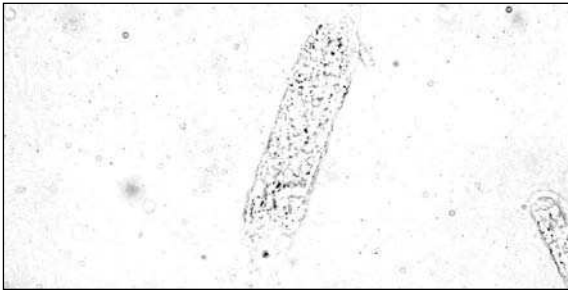

Plate 7.12 Hyaline cast in urine as seen with the 40× objective. Courtesy of M Amphlett.



Plate 7.14 Epithelial cells, red cells and occasional pus cell in urine sediment as seen with the 10× objective.

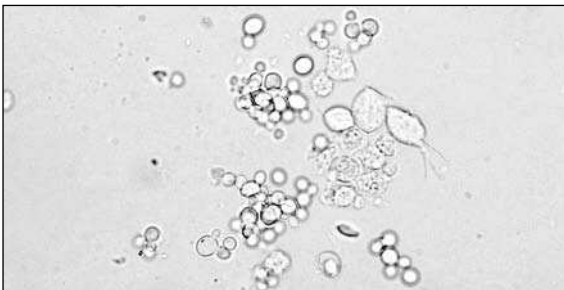

Plate 7.15 Yeast cells and *Trichomonas vaginalis* in urine sediment as seen with the 40× objective. Courtesy of M Amphlett.



Plate 7.17 Egg of *Schistosoma haematobium* and red cells in urine sediment as seen with the 40× objective.

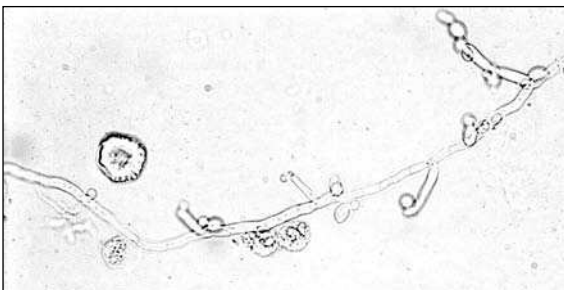

Plate 7.16 Yeast cells and pseudohyphae of *Candida albicans* in urine sediment as seen with the 40× objective. Courtesy of M Amphlett.

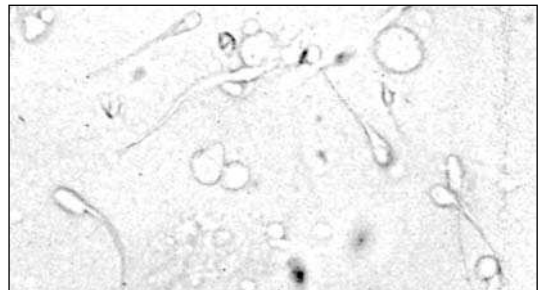

Plate 7.18 Spermatozoa and occasional pus cell in urine sediment as seen with the 40× objective.

seen following strenuous exercise or during fever.

- Waxy casts, which are hyaline casts that have remained in the kidney tubules a long time. They are thicker and denser than hyaline casts, often appear indented or twisted, and may be yellow in colour (see Fig. 7.17). They usually indicate tubular damage and can sometimes be seen in renal failure.
- Cellular casts, which contain white cells or red cells (see Plate 7.13). Red cell casts appear orange red. They indicate haemorrhage into the renal tubules or glomerular bleeding. White cell casts are found when there is inflammation of the kidney pelvis or tubules. Yellow-brown pigmented casts may be seen in the urine of jaundiced patients.
- Granular casts, which contain irregular sized granules originating from degenerate cells and protein. They are also associated with renal damage.

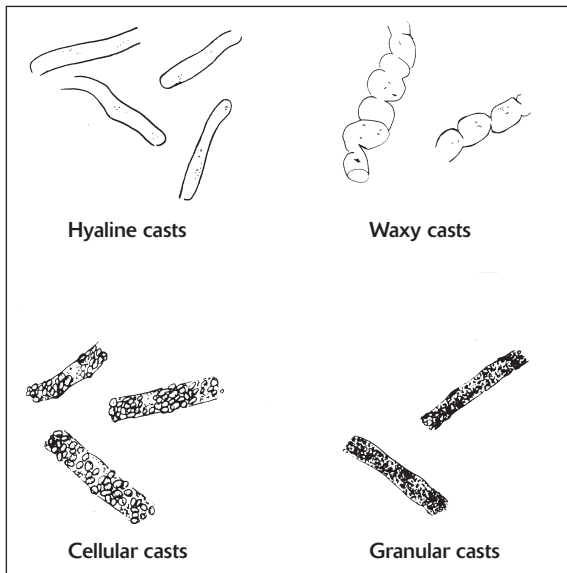

Fig 7.17 Different casts which may be found in urine.

**Epithelial cells:** These are easily seen with the 10× objective (see Plate 7.14). They are nucleated and vary in size and shape. They are usually reported as few, moderate, or many in number per low power (10× objective) field. It is normal to find a few epithelial cells in urine. When seen in large numbers, however, they usually indicate inflammation of the urinary tract or vaginal contamination of the specimen.

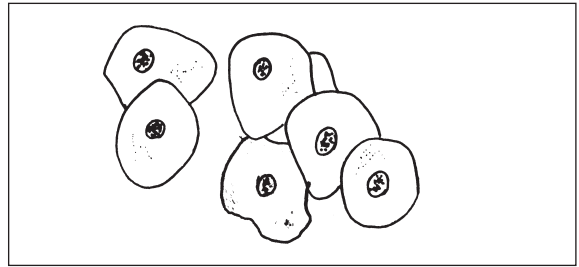

Fig 7.16 Epithelial cells

**Yeast cells:** These can be differentiated from red cells by their oval shape and some of the yeasts usually show single budding (see Plate 7.16). If in doubt, run a drop of dilute acetic acid under the cover glass. Red cells will be haemolyzed by the acid, but not yeast cells.

**Note:** Glove powder in urine also resembles yeasts. It can be distinguished by adding a drop of iodine (as used in Gram stain). Glove powder granules (starch), turn blue-black.

Yeast cells are usually reported as few, moderate, or many per HPF. They can be seen in the urine of women with vaginal candidiasis, and occasionally in specimens from diabetics and those with immunosuppression.

**Trichomonas vaginalis:** Found in the urine of women with acute vaginitis (occasionally seen in the urine of men). The trichomonads are a little larger than white cells and are usually easily detected in fresh urine because they are motile. They move by flagella and an undulating membrane (see Plate 7.15).

**Eggs of *S. haematobium*:** Recognized by their large size (about  $145 \times 55 \mu\text{m}$ ) and spine at one end (see Plate 7.17 and colour Plate 5.40 in Part 1 of the book). The urine will contain red cells and protein. Urinary schistosomiasis is described in subunit 5.6 in Part 1 of the book.

#### Other parasites that may be found in urine

- Very occasionally the microfilariae of *Wuchereria bancrofti* can be found in urine. This happens when a urogenital lymphatic vessel ruptures. The urine appears milky-white or reddish-pink (chyle mixed with blood). The microfilariae are large ( $225\text{--}300 \times 10 \mu\text{m}$ ), motile, and sheathed. No nuclei are present in the tail (feature looked for in a Giemsa stained preparation). *W. bancrofti* microfilariae are shown in colour Plate 5.58b, c in subunit 5.11 in Part 1 of the book.
- Microfilariae of *Onchocerca volvulus* may be found in the urine in onchocerciasis, especially in heavy infections. The larvae are large ( $280\text{--}330 \times 7 \mu\text{m}$ ), unshathed, with a slightly enlarged head-end and a tail which is sharply pointed and contains no nuclei (see colour Plate 5.62 in subunit 5.12 in Part 1 of the book).

- Occasionally the eggs of *Enterobius vermicularis* are found in urine, especially from young girls when the eggs are washed off the external genitalia when urine is being passed (see Plate 5.38 in subunit 5.5 in Part 1 of the book).

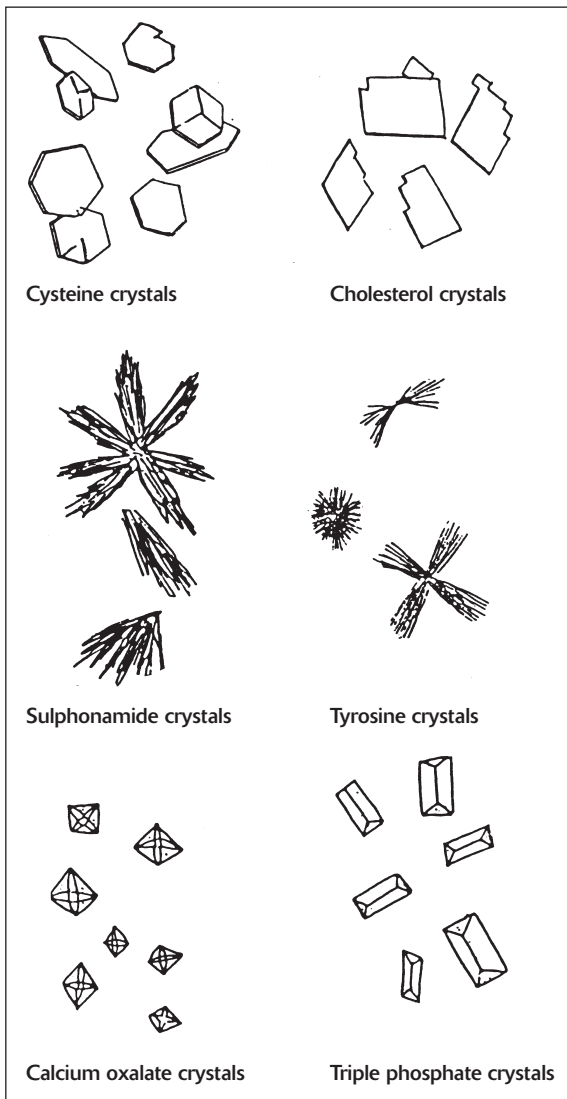

Fig 7.18 Different crystals which may be found in urine.

### Crystals

These have a characteristic refractile appearance. Normal urine contains many chemicals from which crystals can form, and therefore the finding of most crystals has little importance. Crystals should be looked for in fresh urine when calculi (stones) in the urinary tract are suspected. Crystals which may be found in rare disorders include:

- Cystine crystals, which are recognized by their

six-sides (see Fig. 7.18). They are soluble in 30% v/v hydrochloric acid (unlike uric acid crystals which they may resemble). They can be found in cystinuria, a rare congenital metabolic disorder in which cystine is excreted in the urine.

- Cholesterol crystals, which look like rectangles with cut-out corners (see Fig. 7.18). They are insoluble in acids and alkalis but soluble in ether, ethanol, and chloroform. They are rarely found except in severe kidney disease or when a lymphatic vessel has ruptured into the renal pelvis.
- Tyrosine crystals, which are yellow or dark-coloured and look like needles massed together (see Fig. 7.18). They are insoluble in ethanol, ether, and acetone. They are occasionally found in severe liver disease.

### Other crystals found in urine

- Occasionally sulphonamide crystals (see Fig. 7.18) are found in the urine of patients being treated with sulphonamides. When deposited in the urinary tract they can cause haematuria and other complications.
- Triple phosphate crystals are occasionally found in alkaline urine (see Fig. 7.18). They have little or no clinical significance.
- Calcium oxalate crystals are frequently seen (see Fig. 7.18). When found in *freshly* passed urine they may indicate calculi in the urinary tract.
- Uric acid crystals are yellow or pink-brown. They can sometimes be found with calculi.

**Spermatozoa:** Occasionally found in the urine of men, they can be easily recognized by their head and long thread-like tail (see Plate 7.18). They may be motile in fresh urine.

### Contaminants which can be found in urine

These include cotton fibres, starch granules, oil droplets, pollen grains, moulds, single-celled plants (diatoms) and debris from dirty slides or containers.

### Examination of a Gram stained smear

Prepare and examine a Gram stained smear of the urine when bacteria and, or white cells are seen in the wet preparation.

- Transfer a drop of the urine sediment to a slide and spread it to make a thin smear. Allow to air-dry, protected from insects and dust. Heat fix or methanol fix the smear (see subunit 7.3.2) and stain it by the Gram technique as described in subunit 7.3.4.
- Examine the smear first with the 40× objective to see the distribution of material, and then with the oil immersion objective. Look especially for bacteria associated with urinary infections,



especially Gram negative rods. Occasionally Gram positive cocci and streptococci may be seen.

*Note:* Usually only a single type of organism is present in uncomplicated acute urinary infections. More than one type of organism is often seen in chronic and recurring infections. Vaginal contamination of the specimen is indicated by a mixed bacterial flora (including Gram positive rods) and often the presence of epithelial cells.

#### *Neisseria gonorrhoeae* in urine

In male patients with acute urethritis, it is often possible to make a presumptive diagnosis of gonorrhoea by finding Gram negative intracellular diplococci in pus cells passed in urine (see colour Plate 43) and subunit 7.10.

### 3 Test the specimen biochemically

Biochemical tests which are helpful in investigating UTI include:

- Protein
- Nitrite
- Leukocyte esterase

#### *Protein*

Most laboratories test urine routinely for protein using sulphosalicylic acid reagent or a protein reagent strip test, as described on pp. 371–372 in Part 1 of the book. Proteinuria is found in most bacterial urinary tract infections. Other causes include glomerulonephritis, nephrotic syndrome, eclampsia, urinary schistosomiasis, hypertension, severe febrile illnesses, HIV associated renal disease and treatment with nephrotoxic antiretroviral drugs.

#### *Nitrite*

Urinary pathogens, e.g. *E. coli* (commonest cause of UTI), *Proteus* species, and *Klebsiella* species, are able to reduce the nitrate normally present in urine to nitrite. This can be detected by the Greiss test or a nitrite reagent strip test (see pp. 380–381 in Part 1 of the book), providing the organisms are present in the urine in sufficient concentration. When first morning urine is tested, about 80–90% of UTI caused by nitrate-reducing pathogens can be detected. The test is negative when the infection is caused by pathogens that do not reduce nitrate such as *Enterococcus faecalis*, *Pseudomonas* species, *Staphylococcus* species and *Candida* organisms, or when as previously mentioned the bacteria are too few in the urine. Occasionally the nitrite test is negative because nitrate is lacking in the urine due to the person being on a diet lacking in vegetables.

#### **Greiss test to screen for UTI in pregnancy**

A Greiss test to detect nitrite reducing pathogens such as *E. coli*, together with a protein test and the visual examination of urine for cloudiness, are useful ways of screening for UTI in pregnancy in antenatal clinics.

The visual inspection of urine and a test for protein are routinely performed in most antenatal clinics. A simple Greiss test can be performed as follows:

#### *Greiss test using a dry reagent*

- 1 Transfer 0.5–1.0 g (pea-size) of well mixed dry Greiss reagent\* to the well of a white porcelain tile or to a small test tube.

\*Prepare by mixing together 6.2 g *alpha*-naphthylamine, 1 g sulphanic acid, 25 g citric acid. Store in a cool dry place. Renew about every 3 months.

- 2 Moisten the reagent with a drop of urine (first morning urine). The urine should be tested within about 1 hour of being collected.
- 3 Look for the immediate development of a pink-red colour.

Pink-red colour ... Positive nitrite test

#### *Leukocyte esterase (LE)*

This enzyme is specific for polymorphonuclear neutrophils (pus cells). It detects the enzyme from both active and lysed WBCs. LE testing is an alternative method of detecting pyuria when it is not possible to examine fresh urine microscopically for white cells or when the urine is not fresh and likely to contain mostly lysed WBCs.

LE can be detected using a reagent strip test such as the *Combur 2 Test LN* (Roche strip) which detects both nitrite and leukocytes (LE) or a multi-test reagent strip with an area for leukocyte detection (see p. 385 in Part 1 of the book).

False negative strip test results can occur when the urine contains boric acid or excessive amounts of protein (>500 mg/100 ml) or glucose (>2 g/100 ml) (see also p. 381 in Part 1).

**Other biochemical urine tests:** Details of tests to detect other biochemical substances in urine, e.g. glucose, ketones, bilirubin, urobilinogen, and haemoglobin, can be found in subunit 6.11 in Part 1 of the book. The use and control of urine reagent strip tests are also covered in this subunit.

### 4 Culture the specimen

It is *not* necessary to culture urine which is microscopically and biochemically normal, except when screening for asymptomatic bacteriuria in pregnancy. Culture is required when the urine contains bacteria (as indicated by the Gram smear), cells, casts, protein, nitrite, or has a markedly alkaline or acid reaction.

#### *Estimating bacterial numbers*

It is necessary to estimate the approximate number of bacteria in urine because normal specimens may



contain small numbers of contaminating organisms, usually less than 10 000 ( $10^4$ ) per ml of urine. Urine from a person with an untreated acute urinary infection usually contains 100 000 ( $10^5$ ) or more bacteria per ml.

The approximate number of bacteria per ml of urine, can be estimated by using a calibrated loop or a measured piece of filter paper. Both methods are based on accepting that a single colony represents one organism. For example, if an inoculum of  $\frac{1}{500}$  ml produces 20 colonies, the number of organisms represented in  $\frac{1}{500}$  ml of urine is 20, or 10 000 in 1 ml ( $500 \times 20$ ).

The calibrated loop method using quarter plates of culture media (see later text) is recommended because it is inexpensive, simple to perform, and provides individual colonies that are easier to identify and remove for antimicrobial susceptibility testing.

#### **Cystine lactose electrolyte-deficient (CLED) agar**

- Mix the urine (freshly collected clean-catch specimen) by rotating the container.
- Using a sterile calibrated wire loop, e.g. one that holds  $\frac{1}{500}$  ml (0.002 ml), inoculate a loopful of urine on a quarter plate of CLED agar (see No. 30). If microscopy shows many bacteria, use a half plate of medium.
- Incubate the plate aerobically at 35–37°C overnight.

Cystine lactose electrolyte-deficient (CLED) agar is widely used by laboratories to isolate urinary pathogens because it gives consistent results and allows the growth of both Gram negative and Gram positive pathogens. (The indicator in CLED agar is bromothymol blue and therefore lactose fermenting colonies appear yellow). The medium is electrolyte-deficient to prevent the swarming of *Proteus* species.

### Day 2 and Onwards

#### **4 Examine and report the cultures**

##### **CLED agar culture**

Look especially for colonies that could be:

- *Escherichia coli* (perform indole and beta-glucuronidase tests for rapid identification, see subunit 7.5.6)
- *Proteus* species, see subunit 7.18.18
- *Pseudomonas aeruginosa*, see subunit 7.18.20
- *Klebsiella* strains, see subunit 7.18.17
- *Staphylococcus aureus*, see subunit 7.18.1
- *Staphylococcus saprophyticus*, see subunit 7.18.1
- *Enterococcus faecalis*, see subunit 7.18.5

##### **Appearance of some urinary pathogens on CLED agar**

- *E. coli*: Yellow (lactose-fermenting) opaque colonies often with slightly deeper coloured centre.
- *Klebsiella* species: Large mucoid yellow or yellow-white colonies.
- *Proteus* species: Translucent blue-grey colonies.
- *P. aeruginosa*: Green colonies with rough periphery (characteristic colour).
- *E. faecalis*: Small yellow colonies.
- *S. aureus*: Deep yellow colonies of uniform colour.
- *S. saprophyticus* and other coagulase negative staphylococci: Yellow to white colonies.

The appearances of urinary pathogens on CLED agar are shown in colour Plates 18 and 19.

*Note:* Contaminating organisms usually produce a few colonies of mixed growth. Most urinary infections show growth of a single type of organism although mixed infections can occur especially in chronic infections or following catheterization or gynaecological surgery.

##### **Reporting bacterial numbers**

Count the approximate number of colonies. Estimate the number of bacteria, i.e. colony-forming units (CFU) per ml of urine. Report the bacterial count as:

- Less than 10 000 organisms/ml ( $10^4$ /ml), not significant.
- 10 000–100 000/ml ( $10^4$ – $10^5$ /ml), doubtful significance (suggest repeat specimen)
- More than 100 000/ml ( $10^5$ /ml), significant bacteriuria.

##### *Example*

If 25 *E. coli* colonies are counted and a  $\frac{1}{500}$  ml loop was used, the approximate number of CFU per ml of urine:  $500 \times 25 = 12\,500$

Such a count would be reported as:

10 000–100 000 *E. coli*/ml

**Interpretation of bacterial counts:** A bacterial count of  $10^5$  organisms/ml or more from a fresh 'clean-catch' urine specimen, indicates a urinary infection. A count of  $10^4$ – $10^5$ /ml, could mean infection or contamination. A repeat specimen is indicated. A count of less than  $10^4$ /ml is nearly always due to contamination unless the urine was cultured after antimicrobial treatment had been started. It is important, however, to interpret culture counts in relation to the patient's clinical condition. UTIs with lower culture counts are often obtained from catheterized patients or those with urinary obstruction.

##### **Antimicrobial susceptibility testing**

Perform susceptibility testing on urines with significant bacteriuria, particularly from patients with a history of recurring UTI. Cultures from patients with a primary uncomplicated UTI may not require a susceptibility test.

## Summary of the Microbiological Examination of Urine

### Day 1

- |                                  |   |   |
|----------------------------------|---|---|
| <b>1 Describe Appearance</b>     | <ul style="list-style-type: none"> <li>■ <b>Describe</b> <ul style="list-style-type: none"> <li>– Colour</li> <li>– Whether clear or cloudy</li> </ul> </li> </ul>  | ADDITIONAL INVESTIGATIONS   |
| <b>2 Examine Microscopically</b> | <ul style="list-style-type: none"> <li>■ <b>Wet preparation</b><br/>Report:           <ul style="list-style-type: none"> <li>– WBCs (pus cells)</li> <li>– Red cells</li> <li>– Casts</li> <li>– Yeast cells</li> <li>– <i>T. vaginalis</i> flagellates</li> <li>– <i>S. haematobium</i> eggs</li> <li>– Bacteria (fresh urine only)</li> <li>– Crystals of importance</li> </ul> </li> </ul> | <ul style="list-style-type: none"> <li>■ <b>Gram smear:</b> When bacteria or WBCs (pus cells) are seen in wet preparation.</li> </ul> |
| <b>3 Test Biochemically</b>      | <ul style="list-style-type: none"> <li>■ <b>Tests to help diagnose UTI</b> <ul style="list-style-type: none"> <li>– Protein</li> <li>– Nitrite (Greiss test)</li> <li>– Leukocyte esterase (when microscopy for WBCs not possible)</li> </ul> </li> </ul>   | <ul style="list-style-type: none"> <li>■ <b>Glucose, ketones, bilirubin, urobilinogen:</b><br/>As indicated</li> </ul>                |
| <b>4 Culture Specimen</b>        | <ul style="list-style-type: none"> <li>■ <b>CLED agar</b><br/>When bacteria and, or pus cells are present:           <ul style="list-style-type: none"> <li>– Inoculate CLED medium</li> <li>– Incubate aerobically</li> </ul> </li> </ul>  |   |

### Day 2 and Onwards

- |                                      |   |   |
|--------------------------------------|---|---|
| <b>5 Examine and Report Cultures</b> | <ul style="list-style-type: none"> <li>■ <b>CLED culture</b><br/>Look particularly for:           <ul style="list-style-type: none"> <li><i>E. coli</i> (common cause UTI)</li> <li><i>Proteus</i> species</li> <li><i>P. aeruginosa</i></li> <li><i>Klebsiella</i></li> <li><i>E. faecalis</i></li> <li><i>S. aureus</i></li> <li><i>S. saprophyticus</i></li> </ul> </li> </ul> <p>Report bacterial numbers:</p> <ul style="list-style-type: none"> <li>● Less than <math>10^4</math>/ml, not significant</li> <li>● <math>10^4</math>–<math>10^5</math>/ml, doubtful significance</li> <li>● More than <math>10^5</math>/ml, significant bacteriuria.</li> </ul> | <ul style="list-style-type: none"> <li>■ <b>Antimicrobial susceptibility testing:</b><br/>As indicated</li> </ul> |
|--------------------------------------|---|---|

### TESTING URINE FOR HCG (PREGNANCY TESTING)

Human chorionic gonadotrophin (hCG) is a glycoprotein hormone produced by placental cells soon after the fertilized ovum is implanted in the uterine wall. It stimulates the secretion of progesterone by the ovary. Progesterone maintains the uterus during the pregnancy and prevents any further release of eggs from the ovary.

Laboratory pregnancy tests are based on the detection of rapidly rising levels of hCG in urine or serum. The amount of hormone excreted in the urine is almost the same as that found in the blood. At about the time of the first menstrual period, hCG concentrations in urine and serum are about 100 mIU/ml and double in concentration every 1–2 days. Most pregnancies do not require early confirmation by the laboratory.

*Medical reasons for requesting a pregnancy test*  
Include:

- investigation of a suspected ectopic pregnancy, threatened abortion, or a trophoblastic tumour such as hydatidiform mole or choriocarcinoma.
- checking whether a woman of child-bearing age is pregnant before carrying out a medical or surgical investigation, X-ray, or drug treatment that could be harmful to the embryo.

In most of these hCG situations a rapid qualitative hCG test result is adequate. Occasionally it is important to measure the level of hCG e.g. in the investigation of trophoblastic tumour when the concentration of hCG is high and therefore a quantitative test will be required (usually carried out in a specialist laboratory).

#### Qualitative tests to detect hCG in urine

Most of the recently developed immunochromatographic (IC) pregnancy tests have both high sensitivity and specificity. When ectopic pregnancy is suspected it is important to use a sensitive test i.e. one that is capable of detecting hCG levels below 100 mIU/ml. Compared with normal pregnancy, the hCG level is lower in ectopic pregnancy.

Most IC card and strip tests are able to detect 50 mIU/ml or even 25 mIU/ml of hCG. Latex slide tests, however, are generally less sensitive, usually becoming positive only when the hCG level is over 500 mIU/ml.

#### Immunochromatographic (IC) pregnancy tests

Most manufacturers of IC pregnancy tests (see Chart 7.2 on p. 16) use a monoclonal antibody dye conjugate and polyclonal solid phase antibodies to detect hCG in specimens. Some tests can be used to detect hCG in both serum and urine.

The specimen is applied to an absorbent pad. The antibody-dye conjugate binds to the hCG in the specimen forming an hCG antibody-antigen complex. This complex migrates by capillary action to the reaction zone where it binds to the anti-hCG antibody, producing a coloured band (usually pink-rose colour). In a negative test, no coloured band is produced. Unbound conjugate binds to the reagent in the control zone, producing a coloured band, indicating a correctly performed test. A positive pregnancy test is therefore shown by coloured bands appearing in both the control and test zones (see Fig 7.19). A negative test is shown by a coloured band appearing only in the control zone. Most IC tests are rapid, providing results within a few minutes.

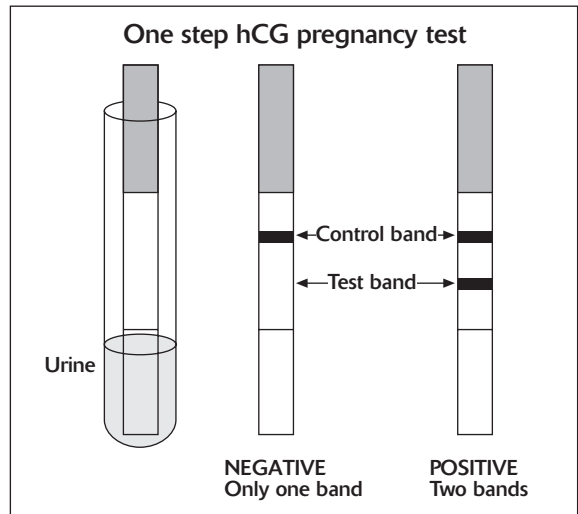

Fig 7.19 Example of a dipstick IC pregnancy test. The strip is dipped in the urine and the result is read after 5 minutes. *Courtesy of Bioline.*

#### Urine specimen

Most manufacturers of urine pregnancy tests recommend testing the first morning urine because this will contain the highest level of hCG. The specimen must be collected in a clean container which is free from all traces of detergent and preservative. When the specimen cannot be tested immediately it should be refrigerated but for not more than 24 hours. The urine and test device must be at room temperature before performing the test.

When the urine is cloudy it should be filtered or centrifuged and the supernatant fluid used. Specimens that contain excessive bacterial contamination or large amounts of protein or blood, are not usually suitable for hCG testing.

It is important to follow exactly the manufacturer's instructions regarding the specimen, method of performing the test, reading of test and control, storage conditions for the test kit and its expiry date. The shelf-life of most IC tests is about 2 years. Many IC pregnancy test kits can be stored at room temperature.

## 7.13 Examination of cerebrospinal fluid (c.s.f.)

### Possible pathogens

#### ■ BACTERIA

##### Gram positive

*Streptococcus pneumoniae*  
*Streptococcus agalactiae*  
 (Group B)\*  
*Listeria monocytogenes*\*  
*Streptococcus suis*\*\*

##### Gram negative

*Neisseria meningitidis*  
*Haemophilus influenzae* type b  
*Escherichia coli*\*  
*Pseudomonas aeruginosa*\*  
*Proteus species*\*  
*Salmonella* serovars  
*Flavobacterium meningosepticum*\*

\*Mainly isolated from neonates (see also *Notes on pathogens*).  
 \*\**S. suis* is a pathogen of pigs. It is an important cause of meningitis in Vietnam, China, and elsewhere among those living in close proximity to pigs.

Also *Mycobacterium tuberculosis* and *Treponema pallidum*.

*Note:* Bacteria may also be found in the c.s.f. when there is a brain abscess, e.g. *Bacteroides* species and other anaerobes.

#### ■ VIRUSES

Particularly coxsackieviruses, echovirus, and arboviruses. Also, herpes simplex 2 virus, varicella zoster virus, and lymphocytic choriomeningitis virus (LCM). Rarely polioviruses may be isolated from cerebrospinal fluid.

#### ■ FUNGI

*Cryptococcus neoformans* (mainly in AIDS patients) and less commonly *Aspergillus* species.

#### ■ PARASITES

*Trypanosoma* species and *Naegleria fowleri*. Rarely the larvae of *Angiostrongylus cantonensis* and *Dirofilaria immitis* (c.s.f. usually contains eosinophils). Also *Toxoplasma gondii* (mainly in AIDS patients).

### Notes on pathogens

- Inflammation of the meninges (membranes that cover the brain and spinal cord) is called meningitis. Pathogens reach the meninges in the blood stream or occasionally by spreading from nearby sites such as the middle ear or nasal sinuses. Fever, headache, neck stiffness, and intolerance of light are typical symptoms of acute bacterial meningitis. In children, vomiting, convulsions and lethargy are common. A haemorrhagic rash is associated with meningococcal meningitis.

Meningitis is described as:

- *Pyogenic (purulent)*, when the c.s.f. contains mainly polymorphonuclear neutrophils (pus cells), as in acute meningitis caused by *N. meningitidis*, *H. influenzae*, and *S. pneumoniae*. Pus cells are also found in the c.s.f. in acute amoebic meningo-encephalitis.
- *Lymphocytic*, when the c.s.f. contains mainly lymphocytes, as in meningitis caused by viruses, *M. tuberculosis*, and *C. neoformans*. Lymphocytes are also found in the c.s.f. in trypanosomiasis meningo-encephalitis, and neurosyphilis.
- In developing countries, meningitis epidemics are usually caused by *N. meningitidis* serogroups A and C and only occasionally by group B and other serogroups. Outbreaks are common in sub-Saharan Africa (meningitis belt) with most group A meningococcal meningitis epidemics occurring in the hot dry season (see also subunit 7.18.12).  
 In recent years meningococcal meningitis has risen to epidemic proportions in some countries of South America, the Middle East, and Asia. Rarely, epidemic meningitis is caused by *S. pneumoniae* but endemic pneumococcal meningitis is common and has a high fatality rate.
- In developing countries, neonatal meningitis is caused mainly by *S. pneumoniae* (about one third of cases), *Salmonella* serovars and other enterobacteria, *N. meningitidis*, and *H. influenzae*. *Streptococcus agalactiae* (Group B) is a rare cause.
- *Haemophilus meningitis* occurs mainly in infants and young children below 5 y with a high incidence below 2 y.
- *C. neoformans* is mainly an opportunistic pathogen, causing life-threatening meningo-encephalitis in those with AIDS and other conditions associated with immunosuppression. In parts of sub-saharan Africa and other areas of high HIV prevalence, cryptococcosis has been reported in up to 30% of AIDS patients.
- Syphilitic meningitis may occur in secondary syphilis but it is usually a complication of late syphilis (see subunit 7.18.32).
- *N. fowleri* causes primary amoebic meningoencephalitis, a rare and usually fatal disease (see pp. 299–300 in Part 1 of the book).

**Commensals:** Cerebrospinal fluid has no normal microbial flora.

### COLLECTION AND TRANSPORT OF CSF

Cerebrospinal fluid *must be* collected by an experienced medical officer or health worker. It must be collected *aseptically* to prevent organisms being introduced into the central nervous system.

The fluid is usually collected from the arachnoid space. A sterile wide-bore needle is inserted between the fourth and fifth lumbar vertebrae and the c.s.f. is allowed to drip into a dry sterile container. A ventricular puncture is sometimes performed to collect c.s.f. from infants.

**Collection of c.s.f. from patient with suspected trypanosomiasis**

When the c.s.f. is to be examined for trypanosomes, it is usually collected after treatment to kill the trypanosomes in the blood has been started. This will avoid the accidental introduction of the parasites into the central nervous system should the lumbar puncture be traumatic (bloody).

**In a hospital with a microbiology laboratory**

**IMPORTANT:** Advise the laboratory before performing a lumbar puncture so that staff are prepared to receive and examine the specimen *immediately*.

*Note:* A delay in examining c.s.f. reduces the chances of isolating a pathogen. It will also result in a lower cell count due to WBCs being lysed, and to a falsely low glucose value due to glycolysis. When trypanosomes are present, they will be difficult to find because they are rapidly lysed once the c.s.f. has been withdrawn.

**Collection of c.s.f.**

- 1 Take two sterile, dry, screw-capped containers and label one No. 1 (first sample collected, to be used for culture), and the other No. 2 (second sample collected, to be used for other investigations).
- 2 Collect about 1 ml of c.s.f. in container No. 1 and about 2–3 ml in container No. 2.
- 3 *Immediately* deliver the samples with a request form to the laboratory.

**In a health centre**

Patients with suspected meningitis usually receive emergency treatment in a health centre and are transferred to the nearest hospital for laboratory investigations and care.

## LABORATORY EXAMINATION OF C.S.F.

**Day 1**

**Important:** Cerebrospinal fluid *must* be examined without delay (see previous text), and the results of tests reported to the medical officer *as soon as they become available*, especially a Gram smear report. The fluid should be handled with special care because a lumbar puncture is required to collect the specimen.

**1 Report the appearance of the c.s.f.**

As soon as the c.s.f. reaches the laboratory, note its appearance. Report whether the fluid:

- is clear, slightly turbid, cloudy or definitely purulent (looking like pus),
- contains blood,
- contains clots.

*Normal c.s.f.* Appears clear and colourless.

**Purulent or cloudy c.s.f.** Indicates presence of pus cells, suggestive of acute pyogenic bacterial meningitis.

**Blood in c.s.f.** This may be due to a traumatic (bloody) lumbar puncture or less commonly to haemorrhage in the central nervous system. When due to a traumatic lumbar puncture, sample No. 1 will usually contain more blood than sample No. 2. Following a subarachnoid haemorrhage, the fluid may appear xanthochromic, i.e. yellow-red (seen after centrifuging).

**Clots in c.s.f.** Indicates a high protein concentration with increased fibrinogen, as can occur with pyogenic meningitis or when there is spinal constriction.

**2 Test the c.s.f.**

Depending on the appearance of the c.s.f., proceed as follows:

**Purulent or cloudy c.s.f.**

Suspect pyogenic meningitis and test the c.s.f. as follows:

- *Immediately* make and examine a Gram stained smear for bacteria and polymorphonuclear neutrophils (pus cells). Issue the report without delay.
- Culture the c.s.f.

**Slightly cloudy or clear c.s.f.**

Test the c.s.f. as follows:

- Perform a cell count and note whether there is an increase in white cells and whether the cells are mainly pus cells or lymphocytes.
- *When cells predominantly pus cells:*
  - Examine a Gram stained smear for bacteria.
  - Examine a wet preparation (sediment from centrifuged c.s.f.) for motile amoebae which could be *Naegleria* (rare).
  - Culture the c.s.f.
- *When cells predominantly lymphocytes:* This could indicate viral meningitis, tuberculous

meningitis, cryptococcal meningitis, trypanosomiasis encephalitis, or other condition in which lymphocyte numbers in the c.s.f. are increased (see Chart 7.9). Perform the following tests:

- Measure the concentration of protein or perform a Pandy's test. The c.s.f. protein is raised in most forms of meningitis and meningoencephalitis.
- Measure the concentration of glucose. This is helpful in differentiating viral meningitis in which the c.s.f. glucose is usually normal from tuberculous meningitis and other conditions in which the c.s.f. glucose is reduced (see Chart 7.9).
- Examine a wet preparation for encapsulated yeast cells that could be *C. neoformans*.
- Examine a wet preparation for trypanosomes and a Giemsa stained smear for morula (Mott) cells when late stage trypanosomiasis is suspected.

**Report the c.s.f. as 'Normal':** when it appears clear, contains no more than  $5 \text{ WBC} \times 10^6/\text{l}$ , and the protein concentration is not raised (or Pandy's test is negative).

*Note:* A c.s.f. begins to appear turbid when it contains about  $200 \text{ WBC} \times 10^6/\text{l}$ .

### GRAM SMEAR

A Gram smear is required when the c.s.f. contains pus cells (neutrophils). It should be the *first* investigation to be performed and reported when the c.s.f. appears purulent or cloudy (suggestive of acute pyogenic meningitis). A Gram smear may also provide useful information when a c.s.f. is unsuitable for cell counting or biochemical testing (e.g. when it is heavily blood stained or contains clots).

#### *Making a smear of c.s.f. for Gram staining*

- 1 Mix No. 2 sample c.s.f. and centrifuge most of it at approximately 1000 g for 5–10 minutes (leave a small amount of uncentrifuged c.s.f. for a cell count should this be required).

**Purulent c.s.f.** Do not centrifuge a purulent fluid. A smear for Gram staining is best prepared from the uncentrifuged c.s.f.

- 2 Transfer the supernatant fluid to another tube (to be used for glucose and protein tests should these be required).
- 3 Mix the sediment. Transfer several drops of the sediment to a slide, but do not make the preparation too thick because this will make it difficult

to decolorize adequately. Allow the preparation to air-dry in a safe place.

- 4 Alcohol-fix the preparation as described in subunit 7.3.2 and stain it by the Gram technique (see subunit 7.3.4).

#### **Examining a c.s.f. Gram smear**

Examine the smear microscopically for pus cells and bacteria using the 40× and 100× objectives.

**Pus cells:** Report as many, moderate number, or few. Pus cells will be found mainly in pyogenic bacterial meningitis and in amoebic-meningo-encephalitis (rare).

**Bacteria:** Look in well stained (not too thick) areas for:

- Gram negative intracellular diplococci that could be *N. meningitidis* (see colour Plate 38).
- Gram positive diplococci or short streptococci, that could be *S. pneumoniae*. It is often possible to see the capsules as unstained areas around the bacteria (see colour Plate 28).
- Gram negative rods, possibly *H. influenzae*, especially if filamentous or other polymorphic forms are seen (see colour Plate 48).

Gram negative rods could also be *E. coli* or other coliforms, especially when the c.s.f. is from a newborn infant.

- Unevenly stained irregular in size yeast cells (some showing budding), suggestive of *C. neoformans* (see colour Plate 74). The large capsule that surrounds the cell does not stain. It is best seen in an India ink preparation (see later text). The smear will usually contain lymphocytes.

**Important:** Advise the medical officer immediately if the Gram smear contains bacteria, pus cells, or yeast cells (confirmed as capsulated in India ink preparation).

#### **Acridine orange stained smear to detect bacteria in c.s.f.**

When facilities for fluorescence microscopy are available, examine an acridine orange (A0) stained smear (see subunit 7.3.11). Bacteria especially when few, are more easily detected in A0 smears. They stain bright orange and cells and debris stain green or yellow. The organisms can be detected using the 40× objective.

*Note:* When bacteria and pus cells are seen in the Gram smear, culture the c.s.f. There is no need to perform a cell count or measure the protein or glucose.

When the patient has been given antibiotics (usually as emergency treatment) it will be more difficult to detect bacteria in the Gram smear and to isolate pathogens in culture.

**Immunological diagnosis of acute bacterial meningitis**

Direct antigen testing of c.s.f. may provide a rapid diagnosis of acute bacterial meningitis, particularly when the patient has been treated with antimicrobials and bacteria cannot be detected in a Gram smear or by culture. Tests are available to detect *N. meningitidis* groups A, B, C, Y and W135 (Group B reagent cross-reacts with *E. coli* K1 antigen), *H. influenzae* type b, *S. pneumoniae*, and *S. agalactiae*.

Manufacturers of latex tests include Bio-Rad Laboratories, BD Diagnostics, and bioMérieux. Coagulation tests are available from Boule Diagnostics.

Details of manufacturers can be found in Appendix 11. The tests, however, are expensive and some manufacturers supply them only in kits containing the full range of tests. Bio-Rad Laboratories, however, make available the different antigen tests individually in pack size of 25, e.g. separate test kits are available for *N. meningitidis* A, and *N. meningitidis* C (useful in determining whether an epidemic is caused by serogroup A or C), *S. pneumoniae* and *H. influenzae* type b.

**CULTURING C.S.F.**

Culture the c.s.f. when bacteria are seen in the Gram smear and, or, cells are present, or the protein concentration is raised.

Use c.s.f. sample No. 1. When the c.s.f. is clear or slightly cloudy, centrifuge the sample in a sterile capped tube for about 15 minutes, and use the sediment to inoculate the culture media.

*Important:* Cerebrospinal fluid must be cultured as soon as possible after collection. When a delay is unavoidable, the fluid should be kept at 35–37°C (not refrigerated).

**Chocolate (heated blood) agar and blood agar**

- Inoculate the specimen on chocolate agar and blood agar (see No. 16). When Gram positive diplococci are seen in the Gram smear, add an optochin disc to the blood agar plate to assist in the identification of *S. pneumoniae*.
- Incubate both plates in a carbon dioxide enriched atmosphere at 35–37°C for up to 48 hours, checking for growth after overnight incubation.

*When patient is a newborn infant:* Inoculate the specimen also on MacConkey agar. Incubate aerobically at 35–37°C overnight.

**CELL COUNT**

A white cell count with an indication whether the cells are pus cells or lymphocytes, is required when the c.s.f. appears slightly cloudy or clear or when the Gram smear does not indicate pyogenic bacterial meningitis.

*Note:* Samples that are heavily blood stained or contain clots are unsuitable for cell counting. Make a Gram smear and report the presence of pus cells and bacteria as previously described.

**Method**

To identify whether white cells in the c.s.f. are polymorphonuclear neutrophils (pus cells) or lymphocytes, dilute the c.s.f. in a fluid which stains the cells. Isonic 0.1% toluidine blue is recommended because it stains lymphocytes and the nuclei of pus cells blue. *C. neoformans* yeast cells stain pink. Red cells remain unstained. The motility of trypanosomes is not affected by the dye. When toluidine blue is unavailable, isotonic methylene blue can be used which will also stain the nuclei of leucocytes. If preferred, leucocytes can be differentiated by examining a Leishman, Giemsa or rapid Field's stained smear (sediment from centrifuged c.s.f.) after counting the cells.

- 1 Mix the c.s.f. (sample No. 2 uncentrifuged c.s.f.). Dilute the fluid 1 in 2, i.e. mix 1 drop of c.s.f. with 1 drop of toluidine blue diluting fluid (Reagent No. 84).\*

\*The drops must be of equal volume, therefore use Pasteur pipettes of the same bore size for both fluids and hold the pipettes vertically when dispensing the drops.

- 2 Assemble a modified Fuchs-Rosenthal ruled counting chamber,\* making sure the chamber and cover glass are completely clean.

\*When unavailable, an improved Neubauer (preferably *Bright-Line*) chamber can be used. A Fuchs-Rosenthal chamber is recommended because it has twice the depth (0.2 mm) and is more suitable for counting WBCs in c.s.f.

- 3 Using a fine bore Pasteur pipette or capillary tube, carefully fill the counting chamber with the well-mixed diluted c.s.f. The fluid must not overflow into the channels on each side of the chamber.
- 4 Wait about 2 minutes for the cells to settle. Count the cells microscopically.
- 5 Focus the cells and rulings using the 10× objective with the condenser iris closed sufficiently to give good contrast. Before starting the count, use the 40× objective to check that the cells are white cells and not red cells (unstained smaller cells without a nucleus) and note whether the white cells are mainly polymorphonuclear neutrophils (with lobed nucleus) or lymphocytes. If a mixture of both, estimate approximately the percentage of each type of cell.

When yeast cells are seen, examine an India ink preparation (see later text).

*Note:* When red cells are seen, mention this in the report. When many red cells are present, the c.s.f. is unsuitable for WBC cell counting.

- 6 Count the cells in 5 of the large squares as shown in Fig. 7.20.

*Note:* When the cells are too many to count, dilute the c.s.f. 1 in 10 (1 drop c.s.f. mixed with 9 drops of diluting fluid), refill the chamber and count the cells. See later text for calculation factor to use.

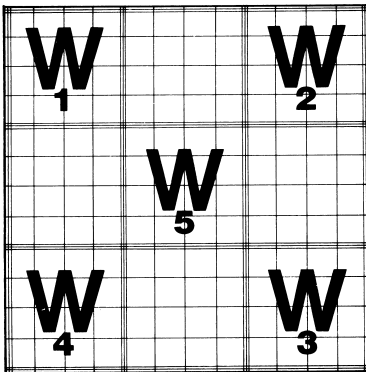

Fig 7.20 Modified Fuchs-Rosenthal ruled chamber. Cells are counted in the squares marked W1, W2, W3, W4, W5.

Multiply the cells counted by 2. Report the number of cells per litre (1) of c.s.f.

*Example* (Using 1 in 2 c.s.f. dilution and Fuchs-Rosenthal chamber)

If 240 cells are counted in 5 squares:

$$240 \times 2 = 480$$

Report as  $480 \times 10^6$  cells/l\*

\*Formerly,  $480 \times 10^6$  cells/l would have been reported as 480 cells/mm<sup>3</sup> or 480 cells/ $\mu$ l.

*When using an Improved Neubauer chamber:* Count the cells in 4 of the large squares as shown in Fig. 7.21. Multiply the cells counted by 5. Report the number of cells per litre of c.s.f.

*Example*

If 64 cells are counted in 4 squares:

$$64 \times 5 = 320$$

Report as  $320 \times 10^6$  cells/l.

### Calculation factors when using 1 in 10 c.s.f. dilution

- *Fuchs-Rosenthal chamber:* Multiply cells counted in 5 squares by 10. Report number of cells per litre of c.s.f. (see above text).

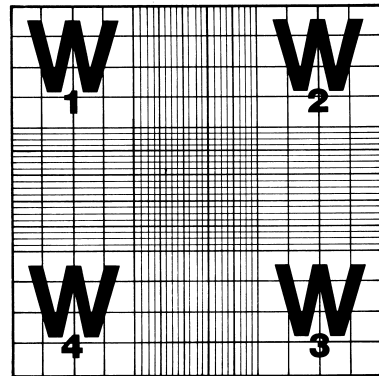

Fig 7.21 Improved Neubauer ruled chamber (can be used when a Fuchs-Rosenthal chamber is not available). Cells are counted in the squares marked W1, W2, W3, W4.

- *Improved Neubauer chamber:* Multiply cells counted in 4 squares by 25. Report number of cells per litre of c.s.f. (see above text).

**Normal c.s.f.:** Contains up to  $5 \times 10^6$  cells/litre (higher in neonates).

When no WBCs are seen, report the count as: Below  $5 \text{ cells} \times 10^6/\text{l}$ .

### BIOCHEMICAL TESTING OF C.S.F.

Biochemical c.s.f. tests which may be required include the measurement of protein and glucose.

*Note:* When the Gram smear shows organisms and pus cells, little additional information will be provided by testing for protein and glucose. When however no bacteria are seen in the Gram smear and the cell count is raised, testing for protein and glucose can help to differentiate those conditions in which lymphocytes are found in c.s.f., e.g. viral meningitis (slightly raised protein, normal glucose) from tuberculous meningitis (high protein, low glucose).

### Measurement of c.s.f. glucose

Glucose must be measured within 20 minutes of the c.s.f. being withdrawn otherwise a falsely low result will be obtained due to glycolysis. Use the supernatant fluid from centrifuged c.s.f. or uncentrifuged c.s.f. if the sample appears clear.

Glucose can be measured in c.s.f. using a colorimetric technique or a simpler semiquantitative technique using Benedict's reagent. Both techniques are described in subunit 6.12 in Part 1 of the book.



*Normal c.s.f. glucose:* This is about half to two thirds that found in blood i.e. 2.5–4.0 mmol/l (45–72 mg%).

*Raised c.s.f. glucose:* Occurs when the blood glucose level is raised (hyperglycaemia) and sometimes with encephalitis.

*Low c.s.f. glucose:* The c.s.f. glucose concentration is reduced in most forms of meningitis, except viral meningitis.

In pyogenic bacterial meningitis it is markedly reduced and may even be undetectable.

### Measurement of c.s.f. total protein and globulin test

Use the supernatant fluid from centrifuged c.s.f. or uncentrifuged c.s.f. when the sample appears clear.

Total protein can be measured in c.s.f. using a colorimetric technique or a visual comparative technique, as described in subunit 6.12 in Part 1 of the book.

Pandy's test is a screening test which detects rises in c.s.f. globulin. It is of value when it is not possible to measure c.s.f. total protein. The method is described in subunit 6.12.

*Normal c.s.f. protein:* Total c.s.f. protein is normally 0.15–0.40 g/l (15–40 mg%). The range for ventricular fluid is slightly lower. Values up to 1.0 g/l (100 mg%) are normal for newborn infants. Only traces of globulin are found in normal c.s.f., insufficient to give a positive Pandy's test.

*Increased c.s.f. total protein with positive Pandy's test:* Occurs in all forms of meningitis, in amoebic and trypanosomiasis meningoencephalitis, cerebral malaria, brain tumours, cerebral injury, spinal cord compression, poliomyelitis, the Guillain-Barré syndrome (often the only abnormality), and polyneuritis. Increases in c.s.f. protein also occur in diseases which cause changes in plasma proteins such as myelomatosis.

When the total protein exceeds 2.0 g/l (200 mg%), the fibrinogen level is usually increased sufficiently to cause the c.s.f. to clot. This may occur in severe pyogenic meningitis, spinal block, or following haemorrhage.

*Note:* In diseases of the nervous system such as multiple sclerosis, neurosyphilis, and some connective tissue disorders it is possible to find a positive Pandy's test for globulin with only a slight rise or even normal total protein.

### ADDITIONAL MICROSCOPICAL INVESTIGATIONS

#### Ziehl-Neelsen smear when tuberculous meningitis is suspected

Examine a Ziehl-Neelsen stained c.s.f. smear for acid fast bacilli (AFB) when tuberculous meningitis is clinically suspected or the c.s.f. contains lymphocytes and the glucose concentration is low and the protein raised. AFB, however, are difficult to detect in c.s.f. The following technique increases the chances of finding the bacteria:

- 1 Centrifuge the c.s.f. at high speed for 20–30 minutes. Remove the supernatant fluid and mix the sediment. Transfer several drops of the sediment to a slide, allowing each drop to dry before adding the next.
- 2 Fix the dry preparation with methanol (see subunit 7.3.2) and stain by the Ziehl-Neelsen technique (see subunit 7.3.5).
- 3 Examine the smear first with 40× objective to see the distribution of material and then with the 100× objective to detect the AFB. Examine the entire preparation. The appearance of *M. tuberculosis* in a Ziehl-Neelsen stained smear is shown in colour Plates 56 and 57.

#### Fluorochrome smear to detect *M. tuberculosis* in c.s.f.

When facilities for fluorescence microscopy are available, examination of an auramine stained smear is a more sensitive method of detecting AFB in c.s.f. The fluorescing rods can be detected using the 40× objective. The auramine staining technique and equipment required for fluorescence microscopy are described in subunit 7.3.6).

#### India ink preparation when cryptococcal meningitis is suspected

When cryptococcal meningitis is clinically suspected, e.g. patient with HIV disease, or when yeast cells are detected when performing a cell count or examining a Gram smear, examine an India ink preparation or a wet preparation by dark-field microscopy for encapsulated yeasts.

- 1 Centrifuge the c.s.f. for 5–10 minutes. Remove the supernatant fluid and mix the sediment.
- 2 Transfer a drop of the sediment to a slide, cover with a cover glass and examine by dark-field microscopy (see subunit 7.3.1) or add a drop of India ink (Pelikan black drawing ink is suitable\*), mix and cover with a cover glass.

\*When ink is not available, use nigrosin 200 g/l (20% w/v) solution.

*Note:* Do not make the preparation too thick otherwise the cells and capsules will not be seen.

- 3 Examine the preparation using the 40× objec-

tive. Look for oval or round cells, some showing budding, irregular in size, measuring 2–10  $\mu\text{m}$  in diameter and surrounded by a large unstained capsule as shown in colour Plate 73. Very occasionally capsules are absent.

*Important:* When encapsulated yeasts are detected in c.s.f., a presumptive diagnosis of cryptococcal meningitis can be made. The medical officer attending the patient should be notified immediately. Further information on *C. neoformans* can be found in subunit 7.18.48.

#### Antigen detection to diagnose cryptococcal meningitis

Soluble antigen can be detected immunologically in both the serum and c.s.f. of patients infected with *C. neoformans*, see subunit 7.18.48.

#### Wet preparation and Giemsa smear when trypanosomiasis meningoencephalitis is suspected

Fresh c.s.f. is required to detect trypanosomes. About 15 minutes after the fluid is withdrawn, the trypanosomes begin to lose their motility and are rapidly lysed. The trypanosomes are usually few and therefore a careful search of a wet preparation is required to detect the motile flagellates.

- 1 Centrifuge the c.s.f. at about 1000 g for 10 minutes. Remove the supernatant fluid and mix the sediment.
- 2 Transfer a drop of sediment to a slide and cover with a cover glass. Examine for motile trypanosomes using the 40 $\times$  objective with the condenser iris closed sufficiently to give good contrast.

Alternatively examine the preparation by dark-field microscopy (see subunit 7.3.1).

**Double centrifugation technique:** When a microhaematocrit centrifuge is available, a more sensitive method of detecting trypanosomes in c.s.f. is to use a double centrifugation technique. This involves transferring the sediment from centrifuged c.s.f. to a capillary tube, and centrifuging it for a further 1 minute in a microhaematocrit centrifuge. The capillary tube is mounted on a slide and the preparation examined for motile trypanosomes as described on p. 263 in Part 1 of the book.

*Note:* African trypanosomiasis and the investigations which are used to diagnose late stage disease including testing for IgM in c.s.f. are described in subunit 5.8 in Part 1 of the book.

#### Giemsa smear to detect morula cells

When no trypanosomes are seen in the wet preparation, remove the cover glass and allow the preparation to air-dry. Fix the smear with methanol

and stain it using Giemsa technique (see subunit 7.3.4) or Field's rapid stain as used for thin films. Examine the preparation for morula cells (IgM producing cells) using the 40 $\times$  objective. The cells are easily recognized. They are larger than lymphocytes with a dark mauve staining nucleus and characteristic vacuoles in their cytoplasm as shown in colour Plate 5.52 on p. 265 in Part 1 of the book. Finding morula cells in the c.s.f. of a person with African trypanosomiasis, indicates central nervous system involvement.

#### Wet preparation to detect amoebae

Examine a wet preparation for motile amoebae when primary amoebic meningoencephalitis is clinically suspected (rare condition caused by *N. fowleri*) or the c.s.f. contains pus cells with raised protein and low glucose, but no bacteria are seen in the Gram smear. Red cells may also be present.

- 1 Transfer a drop of uncentrifuged purulent c.s.f. or a drop of sediment from a centrifuged specimen to a slide and cover with a cover glass.
- 2 Examine the preparation using the 10 $\times$  and 40 $\times$  objectives, with the condenser closed sufficiently to give good contrast. Look for small, clear, motile, elongated forms among the pus cells. Use the 40 $\times$  objective to identify the amoebae (even if not first seen using the 10 $\times$  objective, always examine the preparation with the 40 $\times$  objective).

The amoebae often contain vacuoles but not red cells. Further information on amoebic meningoencephalitis can be found on pp. 299–300 in Part 1 of the book.

*Important:* When amoebae are seen in the c.s.f., immediately notify the medical officer attending the patient. Amoebic meningoencephalitis is a rapidly fatal condition.

### Day 2 and Onwards

#### Examine and report the cultures

##### Chocolate agar and blood agar cultures

Look especially for colonies that could be:

- *Neisseria meningitidis* (growing on chocolate agar and blood agar, oxidase positive (see subunit 7.18.12))
- *Streptococcus pneumoniae* (sensitive to optochin, see subunit 7.18.4)
- *Haemophilus influenzae* (growing only on chocolate agar, see subunit 7.18.24)
- *Cryptococcus neoformans* (Gram stain the colonies, see subunit 7.18.48)

## Summary of the Examination of C.S.F.

### Day 1

#### 1 Report Appearance

- *Describe whether c.s.f.*
  - Clear, slightly turbid, cloudy, purulent
  - Contains blood
  - Contains clots

#### 2 Test c.s.f.

##### Purulent or cloudy c.s.f.

*Suspect pyogenic bacterial meningitis*

- **Gram smear**

Report:

- Number of pus cells
- Bacteria

- **Culture c.s.f.**

- Blood agar and chocolate agar. Incubate in CO<sub>2</sub>
- If neonate: Also MacConkey agar. Incubate aerobically

##### Slightly turbid or clear c.s.f.

- Perform cell count  
Note whether pus cells or lymphs

##### PUS CELLS

- **Gram smear**  
See opposite
- **Culture c.s.f.**  
See opposite

##### ADDITIONAL TESTS

- **Wet preparation:**  
For motile amoebae

##### LYMPHS

- **Measure protein**
- **Measure glucose**
- **Zn:** For AFB
- **India Ink:** For encapsulated yeasts
- **Wet preparation and Giemsa smear:**  
For trypanosomes and morula cells

### Day 2 and Onwards

#### 3 Examine and Report Cultures

- **Chocolate agar and blood agar cultures**  
Look particularly for:  
*N. meningitidis*  
*S. pneumoniae*  
*H. influenzae* (chocolate agar)
- **MacConkey agar culture**  
Look especially for bacteria that cause neonatal meningitis

##### ADDITIONAL

- Perform antimicrobial susceptibility tests as indicated
- **Beta-lactamase test.**  
*H. influenzae* isolates

Chart 7.9 Results of c.s.f. tests in pyogenic bacterial meningitis, other forms of meningitis and meningoencephalitis

	Appearance	Cells (WBCs)	Protein*	Glucose*	Microscopy/Other Tests
<b>Normal c.s.f.</b>	Clear Colourless	Below $5 \times 10^6/1$ , Lymphs	0.15–0.40 g/l (15–40 mg%) <i>Pandy's</i> : Negative	2.5–4.0 mmol/l (45–72 mg%)	
<b>Pyogenic bacterial meningitis</b>	Purulent or cloudy	Usually many Pus cells	High <i>Pandy's</i> : Positive	Very low	<i>Gram</i> : Bacteria may be seen resembling: ● <i>N. meningitidis</i> ● <i>S. pneumoniae</i> ● <i>H. influenzae b</i> (below 5 y) ● Coliforms, <i>S. agalactiae</i> , <i>L. monocytogenes</i> , etc
<b>Viral meningitis</b>	Clear or slightly turbid	Raised Lymphs	Normal or increased <i>Pandy's</i> : Neg/Pos	Usually normal	–
<b>Tuberculous meningitis</b>	Clear or slightly turbid	Raised Lymphs	High <i>Pandy's</i> : Positive	Reduced	<i>Ziehl-Neelsen</i> : AFB difficult to find
<b>Cryptococcal meningitis</b>	Clear or slightly turbid	Raised Lymphs	Usually increased <i>Pandy's</i> : Positive	Normal or reduced	<i>India ink (c.s.f. sediment)</i> Encapsulated yeasts <i>Gram</i> : Unevenly stained yeasts of variable size, some budding
<b>Primary amoebic meningoencephalitis</b>	Cloudy	Raised Pus cells	Increased <i>Pandy's</i> : Positive	Reduced	<i>Wet preparation</i> : Motile amoebae, often with vacuoles
<b>Trypanosomiasis encephalitis</b>	Clear or slightly turbid	Raised Lymphs	High (IgM: very high) <i>Pandy's</i> : Positive	Normal or reduced	<i>Wet preparation (c.s.f. sediment)</i> : Trypanosomes may be seen <i>Giemsa</i> : Morula cells
<b>Syphilitic meningitis</b>	Usually clear	Raised Lymphs	Normal or increased <i>Pandy's</i> : Positive	Normal or increased	Specific treponemal antibody test (serum) will be positive c.s.f. VDRL will be positive

\*Test may not be required when cause of meningitis is indicated from Gram smear or other microscopical examination.

### MacConkey agar culture

Look especially for colonies that could be:

- *Escherichia coli* or other coliform, see subunit 7.18.14.
- *Streptococcus agalactiae*, see subunit 7.18.3.
- *Listeria monocytogenes*, see subunit 7.18.8.
- Other bacteria that cause neonatal meningitis (see previous text).

***Streptococcus suis* identification:** *S. suis* is a non-haemolytic Gram positive coccus, belonging to Lancefield Group D. It is CAMP negative, hydrolyzes aesculin and is able to grow on bile agar.

### Antimicrobial susceptibility testing

Test isolates of *S. pneumoniae* for susceptibility to chloramphenicol and penicillin (use 1 µg oxacillin disc). Test *H. influenzae* for beta-lactamase production (see end of subunit 7.16) and susceptibility to chloramphenicol (using chocolate agar). Perform susceptibility testing on Gram negative rods as indicated.

## 7.14 Culturing blood

Blood culture is required when bacteraemia (septicaemia) is suspected.

### Bacteraemia

The presence of bacteria in the blood is called bacteraemia. It is usually pathological although transitory asymptomatic bacteraemia can occur during the course of many infections and following surgical procedures. Bacteraemia occurs in diseases such as typhoid fever, brucellosis, leptospirosis and endocarditis.

### Septicaemia

This is a clinical term used to describe severe life-threatening bacteraemia in which multiplying bacteria release toxins into the blood stream and trigger the production of cytokines, causing fever, chills, toxicity, tissue anoxia, reduced blood pressure, and collapse. Septic shock is usually a complication

of septicaemia with Gram negative bacilli, and less frequently, Gram positive organisms. Prompt treatment is essential.

Bacteraemia usually occurs when pathogens enter the bloodstream from abscesses, infected wounds or burns, or from areas of localized disease as in pneumococcal pneumonia, meningitis, pyelonephritis, osteomyelitis, cholangitis, peritonitis, enterocolitis and puerperal sepsis. There is usually a high white cell count with neutrophilia, left shift of the neutrophils, and often toxic granulation (see subunit 8.7).

### Possible pathogens isolated from blood cultures

#### ■ BACTERIA

##### Gram positive

*Staphylococcus aureus*  
Viridans streptococci  
*Streptococcus pneumoniae*  
*Streptococcus pyogenes*  
*Enterococcus faecalis*  
*Clostridium perfringens*  
*Anaerobic streptococci*

##### Gram negative

*Salmonella* Typhi  
Other *Salmonella* serovars  
*Brucella* species  
*Haemophilus influenzae*  
*Pseudomonas aeruginosa*  
*Klebsiella* strains  
*Escherichia coli*  
*Proteus* species  
*Bacteroides fragilis*  
*Neisseria meningitidis*  
*Yersinia pestis*

Also *Mycobacterium tuberculosis* (HIV-associated tuberculosis), *Leptospira* species, *Borrelia* species, rickettsiae, and *Bartonella bacilliformis*.

#### ■ FUNGI

*Candida albicans* and other yeasts, e.g. *Cryptococcus neoformans*, and occasionally *Histoplasma capsulatum* and other fungi that cause systemic mycoses.

*Note:* The identification of parasites that can be found in blood (*Plasmodium* species, *Trypanosoma* species, *Leishmania* species and filarial parasites) are described in Part 1 of the book. *Leptospira* species are described in subunit 7.18.33, *Borrelia* species in 7.18.34, rickettsiae in subunit 7.18.35, and *B. bacilliformis* in subunit 7.18.36.

#### Notes on pathogens

- In typhoid, *Salmonella* Typhi can be detected in the blood of 75–90% of patients during the first 10 days of infection and in about 30% of patients during the third week.
- *Salmonella* serovars other than Typhi and Paratyphi are common causes of bacteraemia in children in tropical and developing countries, particularly those who are anaemic and malnourished or have malaria.
- Non-typhoid *Salmonella* (particularly *S. Typhimurium* and *S. Interitidis*) and *S. pneumoniae* are associated with recurring bacteraemia in those infected with HIV.

- Bacteria that cause neonatal septicaemia include *E. coli* and other coliforms, staphylococci, beta-haemolytic Group B streptococci, and less frequently enterococci, *L. monocytogenes*, diphtheroids, and *Candida albicans*.
- Viridans streptococci are the commonest cause of subacute infective endocarditis. Other causes include enterococci, *S. epidermidis*, *H. influenzae*, *Corynebacterium* species, and very occasionally rickettsiae. Acute endocarditis is usually caused by *Staphylococcus aureus*, *Streptococcus pyogenes*, and pneumococci.
- *Y. pestis* can be isolated from the blood in septicaemic plague. The organism is highly infectious.
- Although motile leptospire can occasionally be found in blood (by dark-field microscopy), leptospirosis is usually diagnosed serologically (see subunit 7.18.33).
- *Brucella* species are more likely to be isolated by blood (or bone marrow) culture in acute brucellosis during times of fever. Isolation is rare in *B. abortus* infections. The organisms are slow-growing. They are highly infectious.

### Commensals

Blood does not have a normal microbial flora. Common skin contaminants include coagulase-negative staphylococci, viridans streptococci, micrococci, and *Corynebacterium* species.

## Day 1

### 1 Collect blood and inoculate culture media

Whenever possible blood should be collected before antimicrobial treatment has started. When the patient has recurring fever, collect the blood as the temperature begins to rise. For other patients, collect the blood as soon as possible after receiving the request. To increase the chances of isolating a pathogen, it is usually recommended that at least two specimens (collected at different times) should be cultured. A strict aseptic technique must be used to collect the blood (see later text).

#### Choice of culture media

Media selected for the culture of blood should be capable of providing the fastest growth and isolation of as wide a range of pathogens as possible. The following media are recommended:

- Columbia agar and Columbia broth diphasic medium with added SPS (sodium polyanethol sulphonate), also known as *Liquoid*. SPS prevents the blood from clotting, neutralizes complement and other antibacterial substances in fresh blood, and has some neutralizing effect on polymyxin B, streptomycin, and gentamicin should these be present in the blood. SPS also enables a greater

volume of blood to be cultured without increasing the volume of broth, i.e. up to 50% of the total volume of medium. Preparation of Columbia diphasic medium is described in Appendix II, No. 26.

#### Diphasic blood culture medium

A diphasic (Castenada) medium is one that combines an agar slope with a broth medium (see Plate 7.19). The blood broth is allowed to run over the slope by tipping the bottle at regular intervals. Microbial activity can be seen by growth on the slope (beginning at the broth-agar interface). This avoids the need to subculture from the bottle and therefore reduces the risk of contaminating the culture. When brucellosis is suspected, a diphasic medium is particularly recommended because *Brucella* species are slow-growing and also 'high risk' category 3 pathogens.

#### Use of Columbia agar and broth

Tryptone soya (tryptic soya) diphasic medium is often recommended for culturing blood but organisms such as *S. pneumoniae* and *N. meningitidis* have been shown not to grow well in this medium. Columbia agar and broth are recommended for the isolation of these pathogens and other fastidious organisms. Brucellae, however, grow well in tryptone soya diphasic medium.



Plate 7.19 *Right:* Diphasic blood culture medium. *Left:* Inoculated diphasic medium.

- Thioglycollate broth medium is recommended to isolate strict anaerobes should an anaerobic infection be suspected. It consists of nutrient broth to which is added thioglycollate to provide the conditions necessary for the growth of anaerobes. Because SPS is inhibitory to anaerobic streptococci, it is not added to this medium, therefore a sufficient volume of broth must be used to prevent the blood from clotting and to

dilute out the blood's natural bactericidal substances. The blood should be diluted at least 1 in 10 with broth. Preparation of thioglycollate broth is described in Appendix II, No. 80.

*Isolation of S. Typhi:* If wishing to culture for *S. Typhi* only, the use of ox-gall medium is recommended (see subunit 7.18.16).

#### Commercially produced culture media

A wide range of commercially produced culture media is available for use with manual and automated blood culture systems. Manufacturers of media for non-automated use include Oxoid, Bio-Rad Laboratories, BD Diagnostics and bioMérieux (see Appendix 11). The media are mostly tryptone soy or brain heart infusion broth with added growth factors. Some media are also available with antibiotic removing resins. A few diphasic media are available, e.g. from Bio-Rad Laboratories (in triangular bottles), BD Diagnostics and bioMérieux. The semi-automated Oxoid *Signal* Blood culture system recognizes microbial growth in the blood culture by gas production.

#### Aseptic blood collection and dispensing technique

Blood for culture must be collected and dispensed with great care to avoid contaminating the specimen and culture medium.

- 1 Using a pressure cuff, locate a suitable vein in the arm. Deflate the cuff while disinfecting the venepuncture site.
- 2 Wearing gloves, thoroughly disinfect the venepuncture site as follows:
  - Using 70% ethanol, cleanse an area about 50 mm in diameter. Allow to air-dry.
  - Using 2% tincture of iodine and a circular action, swab the area beginning at the point where the needle will enter the vein. Allow the iodine to dry on the skin for at least 1 minute.
- 3 Lift back the tape or remove the protective cover from the top of the culture bottle(s). Wipe the top of the bottle using an ethanol-ether swab.

#### Prior inspection of culture media bottles

Do not use a bottle of culture medium if it shows signs of contamination, i.e. broth appears turbid. Do not use a bottle of thioglycollate broth if it appears oxidized, i.e. more than a third of the top of the medium appears pink when the indicator in the medium is resazurin, or more than 20 mm down from the surface of the medium appears green-blue when the indicator is methylene blue. When oxidation has occurred, the medium must be reduced by steaming before it is used.

- 4 Using a sterile syringe and needle, withdraw about 20 ml of blood from an adult\* or about

2 ml from a young child.

*\*Note:* When an anaerobic culture is not indicated, collect 10–15 ml of blood.

- 5 Insert the needle through the rubber liner of the bottle cap and dispense 10–12 ml of blood into the diphasic culture medium bottle containing 25 ml of broth (see No. 26).

**Changing needles:** Studies have shown that when dispensing the blood into the culture medium, it is not necessary to replace the needle with a sterile needle. Not changing the needle reduces the risk of accidental needle-prick injury.

When also culturing for anaerobes, dispense about 5 ml of blood into the thioglycollate culture medium containing 50 ml of broth (see No. 80).

Dispense the remaining approximately 2 ml of blood into a tube or bottle containing ethylenediaminetetra acetic acid (EDTA).

**EDTA sample:** This is collected to perform a total and differential white cell count, and to examine stained smears of the plasma buffy coat layer for microorganisms, when the blood is from a child or a patient with AIDS.

- 6 Using a fresh ethanol-ether swab, wipe the top of each culture bottle and replace the tape or protective cover(s). Without delay, mix the blood with the broth and mix the blood in the EDTA container.

*Important:* The blood must not be allowed to clot in the culture media because any bacteria will become trapped in the clot.

- 7 Clearly label each bottle with the name and number of the patient, and the date and time of collection.
- 8 As soon as possible, incubate the inoculated media. Protect the cultures from direct sunlight until they are incubated.

#### *Diphasic medium*

Incubate at 35–37°C for up to 7 days, examining and subculturing as described later. A longer incubation period should be allowed when endocarditis is suspected. When brucellosis is suspected, loosen the cap of the culture bottle (or insert a sterile needle in the cap) and incubate in a carbon dioxide enriched atmosphere (see subunit 7.4) for up to 4 weeks.

#### *Thioglycollate broth*

Incubate at 35–37°C for up to 2 weeks, examining and subculturing as described later.

### **Culture of blood from neonates**

To reduce the risk of contamination, blood from neonates should be collected from a peripheral vein not from the umbilical vein. When only a small amount of blood is obtained, inoculate it into a bottle of diphasic culture medium. Organisms causing bacteraemia in young children are usually present in sufficient concentration to be detected in small volumes of blood (1–2 ml) of blood).

Examine also a Gram stained smear of the plasma buffy coat layer, obtained by centrifuging anticoagulated capillary blood. It is often possible to make a rapid diagnosis of bacteraemia in infants by this method.

### **Plate cultures using lyzed blood to diagnose septicaemia in young children**

Microbiologists in Bangladesh recommend the use of saponin lyzed blood, plated on blood agar and MacConkey agar as a sensitive rapid (within 48 h), and inexpensive technique to diagnose septicaemia in young children.\* Blood (2 ml) is collected into a tube containing 0.2 ml of a filter-sterilized solution of saponin (2 mg) and SPS (0.8 mg). The lyzed blood is inoculated directly onto blood agar and MacConkey agar plates and the plates incubated overnight (blood agar plate in a candle jar). When the blood is likely to contain antibiotics, it is first centrifuged, the supernatant fluid removed, and the sediment used to inoculate the plates.

*\*Further information:* Readers should contact the Consultant Microbiologist, Dhaka Shishu (Children) Hospital, Sher-e-Bangla Nager, Dhaka 1207, Bangladesh.

## **2 Examine the specimen microscopically**

Centrifuge a sample of EDTA anticoagulated venous blood or heparinized capillary blood and make smears of the buffy coat layers. Stain as follows:

- **Gram smear:** To detect Gram positive and Gram negative bacteria, particularly when the patient is an infant or young child.
- **Ziehl-Neelsen smear:** To detect AFB when the patient has AIDS or suspected HIV disease.
- **Giemsa or rapid Field's smear:** To detect borreliae, or parasites such as trypanosomes, malaria parasites, and microfilariae.

*Note:* Microfilariae and trypanosomes are more easily detected by their motility using a microhaematocrit concentration technique (see Part 1 of the book).

Allow the smears to air-dry, fix with absolute methanol for 2 minutes and stain by the appropriate staining technique.

**Day 2 and Onwards**

### 3 Examine and report the cultures

#### **Diphasic culture (Columbia agar and broth)**

Using a hand lens, examine twice daily (up to 7 days or 4 weeks when brucellosis is suspected) for microbial growth, indicated by colonies growing on the agar slope, usually beginning at the agar-broth interface.

#### *Colonial appearances*

Colonies of staphylococci, *S. Typhi*, brucellae, and most coliforms can usually be seen easily, whereas colonies of *S. pneumoniae*, *Neisseria* species, *S. pyogenes*, and *Y. pestis* are less easily seen. *Pseudomonas* and *Proteus* species produce a film of growth on the agar.

When growth is present:

- Subculture on blood agar, chocolate agar, and MacConkey agar.
- Incubate the blood agar and MacConkey agar plates aerobically and the chocolate agar plate in a carbon dioxide atmosphere (candle jar).
- Examine a Gram stained smear of the colonies. Depending on the bacteria seen, test the colonies further (e.g. for coagulase, catalase, oxidase, urease, and motility).
- *When large Gram positive rods resembling C. perfringens are seen:* Subculture also on lactose egg yolk milk agar (see No. 47) and incubate the plate anaerobically (see subunit 7.18.9).
- *When motile, urease and oxidase negative Gram negative rods are isolated:* Subculture the colonies on Kligler iron agar (subunit 7.18.6).
- *When catalase positive Gram negative coccobacilli are isolated:* Suspect *Brucella* species and send the culture (securely) to a microbiology specialist laboratory for identification. Mark the culture 'High Risk'.

#### *Blind subculture after overnight incubation*

Because some organisms such as *Neisseria* species and *S. pneumoniae* may grow without producing easily seen colonies, it is advisable to examine a toluidine blue stained smear and subculture onto agar plates even when no microbial growth is apparent after overnight incubation.

**Important:** Always report immediately a positive blood culture, and send a preliminary report of the stained smear and other useful test

results. When Gram negative rods or staphylococci are seen in a Gram smear, set up appropriate susceptibility tests.

*Note:* When no growth is seen on the slope of the diphasic culture, wash the broth over the slope before reincubating the culture (do not allow the broth to flow into the neck of the bottle).

#### **Thioglycollate broth culture**

Examine daily (up to 14 days) for visible signs of bacterial growth such as turbidity above the red cell layer, colonies growing on the surface of the red cells ('cotton balls'), haemolysis, gas bubbles, and clots. Most organisms (not just anaerobes) grow in thioglycollate broth.

When there are signs of bacterial growth, subculture the broth (see following text) and examine a toluidine blue stained smear for bacteria.

#### **Toluidine blue stained smear of a broth culture**

Bacteria are easier to detect in a broth culture if the preparation is stained using toluidine blue 0.5% w/v (Reagent No. 85) rather than stained by the Gram technique. Make a smear of the broth, allow to air-dry, fix with absolute methanol for 1–2 minutes and stain with toluidine blue for 30–60 seconds. Wash off with water, allow the smear to air-dry, and examine microscopically. When bacteria are detected, examine also a Gram stained smear to identify whether the organisms are Gram positive or negative (unless the organisms can be recognized by their morphology in the toluidine blue preparation).

*Important:* When a patient is seriously ill, subculture the broth (even in the absence of visible bacterial growth) after overnight incubation, after 48 hours, and twice weekly for up to 2 weeks.

#### *Subculturing a blood culture broth*

A strict aseptic technique must be used to avoid contaminating the culture.

- 1 Using an ethanol-ether swab, cleanse the top of the bottle. Using a sterile needle and small syringe, insert the needle through the rubber liner in the cap, and withdraw about 1 ml of the broth culture.
- 2 Inoculate the broth on:
  - Blood agar
  - Chocolate (heated blood) agar
  - MacConkey agar

Incubate the blood agar plate anaerobically for up to 48 hours, the chocolate agar plate in a carbon dioxide atmosphere for up to 48 hours, and the MacConkey agar plate aerobically overnight.



## Summary of Blood Culture Procedures

### Day 1

#### 1 Collect Blood Inoculate culture media

*Using an aseptic technique, dispense:*

- 10–12 ml blood into Columbia agar diphasic medium and mix. Incubate up to 7 days (4 weeks when brucellosis is suspected).
- When anaerobic infection is suspected, dispense 5 ml blood into thioglycollate broth and mix. Incubate up to 14 days.
- 2 ml into EDTA and mix.

#### 2 Examine Microscopically

*Prepare buffy coat smears from EDTA blood:*

- Gram smear
- Giemsa smear

#### ADDITIONAL

**When *S. Typhi* is suspected:**  
Ox-gall broth is recommended

**When brucellosis is suspected:**  
Tryptic soya diphasic medium is recommended

- **Zn smear:** From a patient with AIDS. Look for AFB.

### Day 2 and Onwards

#### 3 Examine and Report Cultures

*After overnight incubation:*

- Examine diphasic culture. Subculture (even when no growth is seen):
  - Blood agar and MacConkey agar. Incubate aerobically
  - Chocolate agar. Incubate in CO<sub>2</sub>.
- Examine toluidine blue smear (diphasic culture).
- Examine thioglycollate culture. Subculture and examine microscopically. Incubate subculture anaerobically.

*Note:* When there is no growth, wash slope of diphasic culture. Reincubate cultures. Subculture as indicated.

**Examine subcultures for likely pathogens**

(See beginning of subunit 7.14)  
Identify organisms

**Perform antimicrobial susceptibility tests as indicated**

- 3 Swab the top of the culture bottle and reincubate.

### Contamination of blood cultures

Contamination can occur when an aseptic technique is not used at the time the blood is collected or at a later stage in the laboratory when subculturing. Frequent contaminants of blood cultures include commensal staphylococci, micrococci, and diphtheroids or contaminants from the environment such as species of *Bacillus* or *Acinetobacter*. Occasionally in immunocompromised patients, organisms usually considered 'contaminants' may be pathogenic, especially fungi.

Contamination is indicated when an organism is recovered from only one bottle when it should have grown in both thioglycollate broth and the diphasic culture medium or when a mixed microbial flora is isolated.

*Note:* An obligatory anaerobe will be isolated from the thioglycollate culture only.

### Bacteriological investigation of a transfusion reaction

Severe and often fatal reactions can be caused by the transfusion of contaminated blood. The bacteriological investigation of a transfusion reaction is as follows:

- 1 Report whether the blood remaining in the unit of transfused blood shows any visible signs of being contaminated such as:
  - appearing unusually dark in colour,
  - containing small clots,
  - the plasma appearing red, or unusually turbid (examine after centrifuging a sample of the blood).

*Note:* Haemolysis does not always occur when blood is contaminated.

- 2 Using an aseptic technique, inoculate three bottles of thioglycollate broth, each with about 4 ml of the well-mixed blood. Mix gently, and label each bottle with the date and unit number of the blood.

Incubate one bottle at 35–37°C, one at room temperature, and refrigerate the other at 4°C for up to 7 days, examining for growth and subculturing as described under 'Examining and reporting of blood cultures'.

- 3 Perform a motility test (see subunit 7.3.2) and examine a Gram stained smear of the plasma.

*Note:* Recognition of bacteria in a Gram smear, especially Gram negative organisms, is often difficult due to background debris.

### *Bacteria that may be found in contaminated bank blood*

These are usually organisms that are capable of growing at room temperature or below. They include coliforms, *Achromobacter* species, and pseudomonads and less commonly *Yersinia* species.

## 7.15 Examination of semen

Analysis of semen (seminal fluid) is included in this chapter because it is often performed in a microbiology laboratory. The values and clinical notes contained in this subunit have been referenced from the *WHO laboratory manual for the examination of human semen and semen-cervical mucus interaction* (see Further information)

When investigating infertility, the basic analysis of semen (seminal fluid) usually includes:

- Measurement of volume
- Measurement of pH
- Examination of a wet preparation to estimate the percentage of motile spermatozoa and viable forms and to look for cells and bacteria.
- Sperm count
- Examination of a stained preparation to estimate the percentage of spermatozoa with normal morphology.

### Collection and transport of semen

- 1 Give the person a clean, dry, leak-proof container, and request him to collect a specimen of semen at home following 3–7 days of sexual abstinence.

*Note:* When a condom is used to collect the fluid, this must be well-washed to remove the powder which coats the rubber. It must be dried completely before being used.

**Coitus interruptus:** This method of collection should not be used because the first portion of the ejaculate (often containing the highest concentration of spermatozoa) may be lost. Also the acid pH of vaginal fluid can affect sperm motility and the semen may become contaminated with cells and bacteria.

- 2 Ask the person to write his name on the container, date and time of collection, period of abstinence, and to deliver the specimen to the laboratory within 1 hour after collection.

During transit to the laboratory, the fluid should

be kept as near as possible to body temperature. This is best achieved by placing the container inside a plastic bag and transporting it in a pocket in the person's clothing.

### LABORATORY EXAMINATION OF SEMEN

*Caution:* Handle semen with care because it may contain infectious pathogens, e.g. HIV, hepatitis viruses, herpes viruses.

#### 1 Measure the volume

Normal semen is thick and viscous when ejaculated. It becomes liquefied usually within 60 minutes due to a fibrinolysin in the fluid. When liquefied, measure the volume of fluid in millilitres using a small graduated cylinder.

*Normal specimens:* Usually 2 ml or more.

#### 2 Measure the pH

- Using a narrow range pH paper, e.g. pH 6.4–8.0, spread a drop of liquefied semen on the paper.
- After 30 seconds, record the pH.

*pH of normal semen:* Should be pH 7.2 or more within 1 hour of ejaculation. When the pH is over 7.8 this may be due to infection. When the pH is below 7.0 and the semen is found to contain no sperm, this may indicate dysgenesis (failure to develop) of the vas deferens, seminal vesicles or epididymis.

#### 3 Estimate the percentage of motile and viable spermatozoa

##### Motility

- Place 1 drop (10–15  $\mu\text{l}$ )\* of *well-mixed* liquefied semen on a slide and cover with a 20  $\times$  20 mm or 22  $\times$  22 mm cover glass.
  - \*1 drop falling from a 21 g needle is equivalent to a volume of 10–15  $\mu\text{l}$ .
- Focus the specimen using the 10 $\times$  objective. *Close the condenser iris sufficiently* to give good contrast. Ensure the spermatozoa are evenly distributed (if not, re-mix the semen and examine a new preparation).
- Using the 40 $\times$  objective, examine several fields to assess motility, i.e. whether excellent (rapid and progressive) or weak (slow and non-progressive). Count a total of 100 spermatozoa, and note out of the hundred how many are motile. Record the percentage that are motile and non-motile.

*Normal motility:* Over 50% of spermatozoa are motile within 60 minutes of ejaculation. The spermatozoa remain motile for several hours.

When more than 60% of spermatozoa are non-motile, examine an eosin preparation to assess whether the spermatozoa are viable or non-viable (see following text).

Presence of cells in semen: Report when more than a few leucocytes (pus cells) or red cells are present. When pus cells are seen, examine a Gram stained smear for bacteria.

##### Viability

- Mix one drop (10–15  $\mu\text{l}$ ) of semen with 1 drop of 0.5% eosin solution\* on a slide.
  - \*Dissolve 0.1 g of eosin in 20 ml of fresh physiological saline.
- After 2 minutes examine the preparation microscopically. Use the 10 $\times$  objective to focus the specimen and the 40 $\times$  objective to count the percentage of viable and non-viable spermatozoa. Viable spermatozoa remain unstained, non-viable spermatozoa stain red.

*Normal viability:* 75% or more of spermatozoa should be viable (unstained). A large proportion of non-motile but viable spermatozoa may indicate a structural defect in the flagellum.

#### 4 Perform a sperm count

- Using a graduated tube or small cylinder, dilute the semen 1 in 20 as follows:
  - Fill the tube or cylinder to the 1 ml mark with well-mixed liquefied semen.
  - Add sodium bicarbonate-formalin diluting fluid (Reagent No. 72) to the 20 ml mark, and mix well.
- Using a Pasteur pipette, fill an Improved Neubauer ruled chamber with *well-mixed* diluted semen. Wait 3–5 minutes for the spermatozoa to settle.
- Using the 10 $\times$  objective with the condenser iris *closed sufficiently* to give good contrast, count the number of spermatozoa in an area of 2 sq mm, i.e. 2 large squares.
  - Note:* The total area of an Improved Neubauer and a Bürker ruled chamber is 9 sq mm, i.e. 9 large squares.
- Calculate the number of spermatozoa in 1 ml of fluid by multiplying the number counted by 100 000.

*Normal count:* 20  $\times$  10<sup>6</sup> spermatozoa/ml or more. Counts less than 20  $\times$  10<sup>6</sup>/ml are associated with male sterility.

### 5 Estimate the percentage of spermatozoa with normal morphology in a stained preparation

- Make a thin smear of the liquefied well-mixed semen on a slide. While still wet, fix the smear with 95% v/v ethanol for 5–10 minutes, and allow to air-dry.
- Wash the smear with sodium bicarbonate-formalin solution (Reagent No. 72) to remove any mucus which may be present. Rinse the smear with several changes of water.
- Cover the smear with dilute (1 in 20) carbol fuchsin and allow to stain for 3 minutes. Wash off the stain with water.
- Counterstain, by covering the smear with dilute (1 in 20) Loeffler's methylene blue for 2 minutes. Wash off the stain with water. Drain, and allow the smear to air-dry.

#### Staining results

Nucleus of head . . . . .	Dark blue
Cytoplasm of head . . . . .	Pale blue
Middle piece and tail . . . . .	Pink-red

**Alternative stains:** Other staining techniques used to stain spermatozoa include Giemsa and Papanicolaou.

#### Morphology of spermatozoa

Examine the preparation for normal and abnormal spermatozoa using the 40× objective. Use the 100× objective to confirm abnormalities. Count 100 spermatozoa and estimate the percentage showing normal morphology and the percentage that appear abnormal.

**Note:** Laboratory staff who have not been trained to report stained semen preparations should request the assistance of a specialist cytology laboratory.

**Normal spermatozoa:** Measure 50–70 μm in length. Each consists of an oval-shaped head (with acrosomal cap) which measures 3–5 × 2–3 μm, a short middle piece, and a long thin tail (at least 45 μm in length). In normal semen, at least 50% of spermatozoa should show normal morphology. Most specimens contain no more than 20% abnormal forms.

**Abnormal spermatozoa:** The following abnormalities may be seen:

#### Head

- Greatly increased or decreased in size.
- Abnormal shape and tapering head (pyriform)

- Acrosomal cap absent or abnormally large.
- Nucleus contains vacuoles or chromatin is unevenly distributed.
- Two heads.
- Additional residual body, i.e. cytoplasmic droplet.

#### Middle piece

- Absent or markedly increased in size.
- Appears divided (bifurcated).
- Angled where it meets tail.

#### Tail

- Absent or markedly reduced in length.
- Double tail.
- Bent or coiled tail.

**Note:** Abnormal semen findings should be checked by examining a further specimen, particularly when the sperm count is low and the spermatozoa appear non-viable and abnormal. When the abnormalities are present in the second semen, further tests are indicated in a specialist centre.

#### Further information

*WHO laboratory manual for the examination of human semen and semen-cervical mucus interaction*, 4th edition, 1999. ISBN 0521645999. Cambridge University Press.

## 7.16 Antimicrobial susceptibility testing

Antimicrobial agents include naturally occurring antibiotics, synthetic derivatives of naturally occurring antibiotics (semi-synthetic antibiotics) and chemical antimicrobial compounds (chemotherapeutic agents). Generally, however, the term 'antibiotic' is used to describe antimicrobial agents (usually antibacterial) that can be used to treat infection. Compared with antibacterial agents, fewer antiviral and antifungal agents have been developed. Many antiviral agents have serious side-effects e.g. those used to treat HIV infection.

#### Antimicrobial activity

Not all antimicrobials, at the concentration required to be effective are completely non-toxic to human cells. Most, however, show sufficient selective toxicity to be of value in the treatment of microbial diseases.

Antibacterial agents can be grouped by their mode of action, i.e. their ability to inhibit the synthesis of the cell wall, cell membrane, proteins, and nucleic acids of bacteria.

**Mode of action of antimicrobial agents****INHIBITORS OF BACTERIAL CELL WALL SYNTHESIS**

- **Penicillins** (*Beta-lactam agents*)
 

Benzylpenicillin	Cloxacillin
(Penicillin G)	Carbenicillin
Phenoxymethyl penicillin (V)	Ticarcillin
Ampicillin	Azlocillin
Amoxycillin	Piperacillin
Flucloxacillin	Mecillinam
- **Cephalosporins** (*Beta-lactam agents*)
 

Cephadrine*	Ceftazidime***
Cefuroxime**	Cefotaxime***

\*1st generation, \*\*2nd generation, \*\*\*3rd generation
- **Glycopeptides**

Vancomycin	Teicoplanin
------------	-------------
- **Carbapenems**

Imipenem	Meropenem
----------	-----------

**INHIBITORS OF PROTEIN SYNTHESIS**

- **Aminoglycosides**

Gentamicin	Streptomycin
Tobramycin	Amikacin
Kanamycin	Netilmicin
- **Macrolides**

Erythromycin	
--------------	--
- **Lincosamides**

Clindamycin	
-------------	--
- **Chloramphenicol**
- **Tetracyclines**

Tetracycline	Doxycycline
--------------	-------------

**INHIBITORS OF BACTERIAL NUCLEIC ACID SYNTHESIS**

- **Quinolones**, e.g.
 

Nalidixic acid	Fluroquinolones*
	*e.g. Ciprofloxacin, Norfloxacin
- **Sulphonamides and Trimethoprim**, e.g.
 

Co-trimoxazole	Trimethoprim
Sulphadimidine	Sulphadoxine
- **Metronidazole**

**ANTIMYCOBACTERIAL AGENTS**

Rifampicin	Ethambutol
Isoniazid	Diamino-diphenylsulphone (dapsone)
Pyrazinamide	

**OTHER ANTIBACTERIAL AGENTS**

Fusidic acid  
Nitrofurantoin  
Spectinomycin

**ANTIFUNGAL AGENTS**

Amphotericin B and nystatin  
Flucytosine      Triazoles  
Imidazoles      Griseofulvin and terbinafine

**ANTIVIRAL AGENTS**

Aciclovir	Ganciclovir
Against herpes group viruses	Used for treatment of CMV infections.

**Tribavirin (ribavirin)**

Used mainly in severe respiratory syncytial virus infection and in some viral haemorrhagic fevers

**Interferons/Peginterferon**

Inhibit replication of hepatitis B and C viruses.

*Note:* Antiretroviral agents are described in subunit 7.18.55.

**Notes on antimicrobial agents**

**Penicillins:** Bactericidal agents benzylpenicillin (i.m., i.v. administration) and penicillin V (oral) are used to treat infections caused by streptococci, pneumococci, clostridia and when sensitive, also staphylococcal infections, meningitis, gonorrhoea, syphilis and anthrax. Flucloxacillin and cloxacillin are used to treat *beta*-lactamase (penicillinase) producing staphylococci. Ampicillin and amoxycillin are broad-spectrum penicillins, active against Gram positive bacteria (including enterococci) *H. influenzae*, and many coliforms. Carbenicillin and ticarcillin are useful in treating infections caused by *P. aeruginosa*. Azlocillin and piperacillin are active against klebsiellae and are also anti-pseudomonal.

Hypersensitivity reactions include anaphylaxis (IgE mediated), delayed hypersensitivity (IgG mediated), erythema nodosum, and skin rashes. Patients with penicillin hypersensitivity may also show allergy to cephalosporins. Anti-bacterial resistance to penicillins may occur due to *beta*-lactamase production, cell membrane alterations reducing antibiotic uptake (Gram negative bacteria), or changes in penicillin-binding proteins as occurs with MRSA (methicillin-resistant *S. aureus*). MRSA are usually resistant to many antibiotics (e.g. penicillins, tetracyclines, erythromycin, and sometimes gentamicin). Severe infections require treatment with vancomycin. MRSA vancomycin-intermediate strains have been reported.

**Cephalosporins:** Like penicillin, cephalosporins are bactericidal and also have a *beta*-lactam ring. They are, however, stable to staphylococcal penicillinase and have broad spectrum activity. They are less likely to cause hypersensitivity than penicillin. They are mainly used to treat severe systemic infections caused by aerobic Gram negative organisms. They are expensive drugs. Some cephalosporins can damage the kidneys.

**Glycopeptides:** Bactericidal I.V. administered expensive agents. Vancomycin is used to treat serious infections such as endocarditis and septicaemia caused by Gram positive bacteria, particularly multi-resistant strains. Treatment requires monitoring due to ototoxicity (damage to hearing) and nephrotoxicity (kidney damage).

**Carbapenems:** These *beta*-lactam antibiotics have a potent activity against a wide range of Gram positive and Gram negative bacteria and are resistant to hydrolysis by *beta*-lactamases.

**Aminoglycosides:** Bactericidal, showing synergy with *beta*-lactam agents. Mainly reserved for the treatment of severe sepsis due to coliforms and other Gram negative aerobic bacilli. With *beta*-lactams, they are sometimes used to treat endocarditis caused by staphylococci and streptococci.

Side-effects include hypersensitivity reactions, ototoxicity, and nephrotoxicity.

**Macrolides:** Useful bacteriostatic agents (maybe bactericidal at high concentration). Mainly used to treat staphylococcal infections, respiratory infections, non-specific urethritis, and when indicated, *Campylobacter* enteritis. They are useful second-line drugs for treating patients with penicillin hypersensitivity. Resistance may occur with *S. aureus*, *S. pyogenes*, and *S. pneumoniae*. Side effects include gastrointestinal upsets and rashes.

**Lincosamides:** Useful in treating staphylococcal bone and joint infections and anaerobic infections, but lincosamides have been associated with pseudomembranous colitis.

**Chloramphenicol:** Bacteriostatic broad spectrum drug, used in treating typhoid fever, meningitis, rickettsial and chlamydial infections and also eye infections (in eye drops). It can cause aplastic anaemia and is toxic in neonates.

**Tetracycline:** Bacteriostatic widely used broad spectrum antibiotic with activity against Gram positive and some Gram negative bacteria and also borreliae, rickettsiae, chlamydiae, *C. burnetii*, and mycoplasmas. Side effects include gastrointestinal disturbances, kidney damage, and staining of teeth in children. It should not be used in pregnancy. Resistance to tetracycline is common, e.g. with *H. influenzae*, *S. pneumoniae*, and *S. pyogenes*.

**Quinolones:** Bacteriostatic or bactericidal agents. Nalidixic acid is used to treat lower Gram negative urinary infections. Ciprofloxacin (fluroquinolone) is active against *Pseudomonas* and is also used to treat serious systemic infections.

**Sulphonamides and trimethoprim:** Bacteriostatic agents (may be bactericidal in combination) with activity against Gram positive and Gram negative organisms (*P. aeruginosa* is resistant). Co-trimoxazole is used to treat urinary and respiratory tract infections, *Pneumocystis pneumoniae*, and invasive salmonellosis. Many enterobacteria are resistant. Side-effects include nausea and vomiting, rashes, mouth ulceration and occasionally thrombocytopenia and leucopenia. Side-effects are less with trimethoprim.

**Metronidazole:** Bactericidal agent used to treat anaerobic infections, e.g. caused by *Bacteroides*, anaerobic cocci and clostridia. Actinomyces are resistant. Also used to treat Vincent's angina and protozoal infections, e.g. caused by *T. vaginalis*, *E. histolytica*, *G. lamblia*. Few side-effects.

**Antimycobacterial agents:** Resistance to most antimycobacterial agents develops rapidly. When treating tuberculosis and leprosy, a combination of antimicrobial agents is therefore used. Rifampicin may affect liver function. It should not be used in the early stages of pregnancy. It gives a red colour to urine (also tears and sputum). Pyrazinamide may also be hepatotoxic. Eye damage may occur with ethambutol. Multi-drug therapy for leprosy includes using dapsone, clofazimine and rifampicin. In the treatment of tuberculosis, isoniazid and ethambutol are bactericidal (in certain situations), and rifampicin and pyrazinamide sterilize tuberculous lesions. Strains of *M. tuberculosis* resistant to multiple drugs are becoming increasingly reported, e.g. in association with HIV infection.

### *Bacteriostatic and bactericidal agents*

Antibacterial agents are generally described as bacteriostatic when, at usual dosages, they prevent the active multiplication of bacteria, e.g. chloramphenicol, tetracycline, and erythromycin.

Antibacterial agents are described as bactericidal when, at usual dosages, they kill bacteria, e.g. the penicillins, cephalosporins, glycopeptides and aminoglycosides. Some bacteriostatic agents become bactericidal when used at higher concentrations, e.g. erythromycin and tetracycline.

### *Broad spectrum antibiotics*

The term 'broad spectrum' is applied to antibacterials with activity against a wide range of Gram positive and Gram negative organisms. They include some  $\beta$  lactam antibiotics and the tetracyclines, aminoglycosides, sulphonamides, and chloramphenicol. Narrow spectrum antibiotics are those with activity against one or few types of bacteria, e.g. vancomycin against staphylococci and enterococci.

In theory it is always better to use narrow spectrum antibiotics once the infective agent is known as this limits the detrimental effects on the normal bacterial flora.

### *Antibiotics used in combination*

Occasionally, combinations of antimicrobials are used to treat mixed infections to prevent treatment failure and drug resistance from developing, to treat severe infections when the organism is not known, or when it is necessary to obtain a greater antimicrobial effect from two bactericidal drugs acting together (synergistic effect).

### **Antimicrobial resistance**

Most of the antimicrobial resistance which is now making it difficult to treat some infectious diseases is due to the extensive use and misuse of antimicrobial drugs which have favoured the emergence and survival of resistant strains of micro-organisms. Drug-resistant strains are common among staphylococci, gonococci, meningococci, pneumococci, enterococci, Gram negative bacteria (e.g. *Salmonella*, *Shigella*, *Klebsiella*, *Pseudomonas*) and *M. tuberculosis*.

Bacteria become resistant to antimicrobial agents by a number of mechanisms, the commonest being:

- production of enzymes which inactivate or modify antibiotics,
- changes in the bacterial cell membrane, preventing the uptake of an antimicrobial,
- modification of the target so that it no longer interacts with the antimicrobial.
- development of metabolic pathways by bacteria

which enable the site of antimicrobial action to be bypassed.

To acquire these new properties bacteria must undergo a genetic change. Such a genetic change may occur by mutation or by the acquisition of new genetic material. New genetic material is acquired by the transfer of resistance genes, (located on plasmids and transposons) from one bacterium to another. Some plasmids encode for resistance to several antibiotics and can be transferred between bacterial species, e.g. from *Escherichia coli* to *Shigella dysenteriae*.

#### Examples of bacterial resistance mechanisms

- Production of *beta*-lactamase enzymes that destroy the *beta*-lactam ring of penicillins and cephalosporins (commonest form of resistance).
- Production of acetylating, adenylating and phosphorylating enzymes that inactivate antimicrobials such as aminoglycosides and chloramphenicol.
- Altering the permeability of the outer membrane of the bacterial cell wall as occurs in resistance to tetracyclines (common form of resistance in *P. aeruginosa*). The cell wall of streptococci forms a natural barrier to aminoglycosides.
- Production of metabolic pathways that bypass the site of antimicrobial action as in resistance to sulphonamides and trimethoprim.

*Note:* The emergence of drug resistance in infections may be minimized by maintaining sufficiently high levels of the drug in the tissues to inhibit mutants, administering two drugs that do not give cross-resistance (each delays the emergence of mutants resistant to the other drug), and by limiting the use of valuable second line 'reserve drugs' such as the cephalosporins and quinolones.

#### *Antimicrobial resistance in developing countries*<sup>12</sup>

Acquired antimicrobial resistance is a growing worldwide problem due to the increasing use of antimicrobials in humans, animals, and agriculture. In developing countries the situation is particularly serious for the following reasons:

- In many countries, antimicrobials can be obtained outside of recognized treatment centres, and taken without medical authorization or supervision. This leads to the inappropriate use of antimicrobials and their being taken at sub-optimal dosages and for an insufficient length of time. Often the high cost of an antibiotic, results in an incomplete course being purchased, sufficient only to alleviate symptoms.
- Patients are not sufficiently informed about antibiotics and their use. Problems also arise when antibiotics sold in local markets are fake drugs, sub-standard, or expired drugs.
- Guidelines regarding the selection of drugs,

correct prescribing, and information about drug resistance and how to minimize its spread are not communicated to those purchasing and prescribing antimicrobials.

- Antibiotics are often prescribed when they are not needed or for self-limiting infections, e.g. diarrhoeal disease and viral respiratory infections.
- Broad spectrum antibiotics are frequently used prophylactically, e.g. tetracycline.
- Laboratory facilities for accurate diagnosis and isolation of pathogens are often not available, resulting in an overuse and inappropriate use of antibiotics.
- Overcrowding and poor hygiene and sanitation facilitate the spread of resistant organisms, e.g. bacteria that cause tuberculosis, typhoid, pneumonia.
- Infection control procedures in hospitals are often inadequate, resulting in the spread of infectious diseases and resistant strains of organisms such as *S. aureus* (MRSA), *P. aeruginosa*, *E. coli*, *Klebsiella*, *Proteus*, *Enterococcus* and *Salmonella* serovars.
- Many countries do not have effective surveillance of important antimicrobial-resistant bacteria. Training and facilities for performing standardized antimicrobial susceptibility tests are often lacking.
- Developing countries are often unable to afford costly second-line antibiotics to treat infections due to resistant organisms. This results in prolonged illness with longer periods of infectivity and the further spread of resistant strains.

In recent years resistance to first-line antibiotics such as ampicillin, tetracyclines, chloramphenicol and sulphonamides, has been increasing. Many gonococcal and pneumococcal infections are resistant to penicillin. Resistance to most commonly available antimicrobials is also an increasing problem in bacillary dysentery caused by *Shigella dysenteriae* 1, meningitis caused by *Haemophilus influenzae* type b strains, and enteric fever caused by *Salmonella* Typhi.

---

#### ANTIMICROBIAL SUSCEPTIBILITY TESTING

In the treatment and control of infectious diseases, especially when caused by pathogens that are often drug resistant, susceptibility (sensitivity) testing is used to select effective antimicrobial drugs. Susceptibility testing is not usually indicated when

the susceptibility reactions of a pathogen can be predicted, for example:

- *Proteus* species are generally resistant to nitrofurantoin and tetracyclines,
- *S. pyogenes* is usually susceptible to penicillin,
- *K. pneumoniae* is generally ampicillin resistant,
- Anaerobes are susceptible to metronidazole.

Susceptibility tests must never be performed on commensal organisms or contaminants because this would mislead the clinician and could result in the patient receiving ineffective and unnecessary antimicrobial therapy, causing possible side effects and resistance to other potentially pathogenic organisms.

#### Limitations of antimicrobial susceptibility tests

Susceptibility tests measure antimicrobial activity against bacteria under laboratory conditions (*in vitro* activity), not in the patient (*in vivo* activity). It cannot be assumed therefore, that an antimicrobial which kills or prevents an organism from growing *in vitro* will be a successful treatment.

Selecting appropriate antimicrobial treatment also involves considering the patient's clinical condition, any underlying condition (e.g. liver or kidney disease), the type and site of the infection, any history of drug hypersensitivity, age of patient and whether a patient is pregnant. It is also necessary to know the activity of the different drugs including their rates of absorption, diffusion in the tissues, metabolism, excretion and also possible toxicity and effects on the patient's normal microbial flora. The cost and availability of a drug will also need to be considered.

#### Susceptibility testing techniques

Laboratory antimicrobial susceptibility testing can be performed using:

- A dilution technique
- A disc diffusion technique.

**Dilution susceptibility tests:** Manual or semi-automated dilution susceptibility tests are performed in Microbiology Reference Laboratories for epidemiological purposes or when a patient does not respond to treatment thought to be adequate, relapses while being treated, or when there is immunosuppression. Dilution techniques measure the minimum inhibitory concentration (MIC). They can also be used to measure the minimum bactericidal concentration (MBC) which is the lowest concentration of antimicrobial required to kill bacteria.

A dilution test is carried out by adding dilutions of an antimicrobial to a broth or agar medium. A standardized inoculum of the test organism is then added. After overnight incubation, the MIC is reported as the lowest concentration of antimicrobial required to prevent visible growth. By comparing the MIC value with known concentrations of the drug obtainable in serum or other body fluids, the likely clinical response can be assessed.

*Note:* The simplified *Etest* method of obtaining MIC is described on p. 142.

**Disc diffusion susceptibility tests:** Disc diffusion techniques are used by most laboratories to test routinely for antimicrobial susceptibility. A disc of blotting paper is impregnated with a known volume and appropriate concentration of an antimicrobial, and this is placed on a plate of susceptibility testing agar uniformly inoculated with the test organism. The antimicrobial diffuses from the disc into the medium and the growth of the test organism is inhibited at a distance from the disc that is related (among other factors) to the susceptibility of the organism. Strains susceptible to the antimicrobial are inhibited at a distance from the disc whereas resistant strains have smaller zones of inhibition or grow up to edge of the disc. For clinical and surveillance purposes and to promote reproducibility and comparability of results between laboratories, WHO recommends the (NCCLS\*) modified Kirby-Bauer disc diffusion technique.

\*National Committee for Clinical Laboratory Standards.

#### Kirby-Bauer NCCLS modified disc diffusion technique

The validity of this carefully standardized technique depends on, for each defined species, using discs of correct antimicrobial content, an inoculum which gives confluent growth, and a reliable Mueller Hinton agar. The test method must be followed exactly in every detail. After incubation at 35°C for 16–18 hours, zone sizes are measured and interpreted using NCCLS standards. These are derived from the correlation which exists between zone sizes and MICs.\*

\*An approximately linear relationship exists between log MIC as measured by the dilution test, and the inhibition zone diameter in the diffusion test. A regression line expressing this relationship can be obtained by testing a large number of strains by both techniques. This has been done and enables zone diameter sizes to be correlated to MIC values in the NCCLS modified Kirby-Bauer technique.

The NCCLS Kirby-Bauer technique should only be used for well-evaluated bacterial species. It is not suitable for bacteria that are slow-growing, need special nutrients, or require CO<sub>2</sub> or anaerobic incubation.

**Stokes disc diffusion technique:** In this disc technique both the test and control organisms are inoculated on the same plate. The zone sizes of the test organism are compared directly with that of the control. This method is not as highly standardized as the Kirby-Bauer technique and is used in laboratories particularly when the exact amount of antimicrobial in a disc cannot be guaranteed due to



difficulties in obtaining discs and storing them correctly or when the other conditions required for the Kirby-Bauer technique cannot be met.

One way laboratories in developing countries performing the Stokes technique could change to a technique comparable to the WHO recommended Kirby-Bauer technique is to use highly stable Rosco Diagnostica antibiotic tablets (*Neo-Sensitabs*) instead of less stable paper discs.

#### Rosco *Neo-Sensitabs* susceptibility testing

*Neo-Sensitabs* antimicrobial tablets are standardized according to the 2004 MIC-breakpoints recommended by the NCCLS. The tablets are 9 mm in diameter and colour-coded. The formulae used to produce the tablets gives them a shelf-life of about 4 years and many *Neo-Sensitabs* can be stored at room temperature.

The same principles and quality control as used in the modified Kirby-Bauer method apply when using *Neo-Sensitabs*. An excellent 2004 booklet *User's Guide-Neo-Sensitabs Susceptibility Testing* is available from Rosco Diagnostica. This describes the principles and how to perform susceptibility testing and exactly how to measure and interpret zone sizes. The cost and local availability of *Neo-Sensitabs* can be obtained from Rosco Diagnostica (see Appendix 11).

#### Modified Kirby-Bauer susceptibility testing technique

##### REQUIRED

- *Mueller Hinton agar*

Prepare and sterilize the medium as instructed by the manufacturer. The pH of the medium should be 7.2–7.4. Pour into 90 mm diameter sterile petri dishes to a depth of 4 mm (about 25 ml per plate). Care must be taken to pour the plates on a level surface so that the depth of the medium is uniform.

**Note:** If the medium is too thin the inhibition zones will be falsely large and if too thick the zones will be falsely small.

Control each new batch of agar by testing it with a control strain of *E. faecalis* (ATCC 29212 or 33186) and co-trimoxazole disc. The zone of inhibition should be 20 mm or more in diameter. Store the plates at 2–8 °C in sealed plastic bags. They can be kept for up to 2 weeks. For use, dry the plates with their lids slightly raised in a 35–37 °C incubator for about 30 minutes.

**Fastidious organisms:** Unmodified Mueller Hinton agar is not suitable for susceptibility testing *H. influenzae*, *S. pneumoniae*, *N. gonorrhoeae*. Isolates of these organisms should be sent to a specialist microbiology laboratory for testing. Alternatively, the addition of lysed blood will enable such organisms to be tested.

- *Antimicrobial discs*

The choice of antimicrobials to be included in

susceptibility tests will depend on the pathogen, the specimen, range of locally available antimicrobials, and local prescribing policies. Consultation between laboratory, medical, and pharmacy staff is required. The range of first choice drugs should be limited and reviewed at regular intervals. Additional drugs should be included only by special request. Where there is cross-resistance, only one member from each group of related antimicrobials need be selected. An oxacillin disc is representative of the whole group of *beta*-lactamase resistant penicillins when testing staphylococci.

**Note:** Paper antimicrobial discs are commercially available from most manufacturers of culture media. Stable antimicrobial susceptibility testing tablets are available from Rosco Diagnostica (see previous text). Most paper discs can be used for 1 year or longer from the date of manufacture providing they are stored correctly (–20 °C, or working stock at 2–8 °C in an airtight container with an indicating desiccant. Discs that have expired should not be used. Quality control of discs is essential.

About 1 hour before use, the working stock of discs should be allowed to warm to room temperature, protected from direct sunlight.

**Important:** Decreasing control zone sizes with a particular antimicrobial disc is often an indication of deterioration of the antimicrobial due to moisture or heat.

- *Turbidity standard equivalent to McFarland 0.5*

This is a barium sulphate standard against which the turbidity of the test and control inocula can be compared. When matched with the standard, the inocula should give confluent or almost confluent growth. Shake the standard immediately before use.

#### Preparation of turbidity standard

- 1 Prepare a 1% v/v solution of sulphuric acid by adding 1 ml of concentrated sulphuric acid to 99 ml of water. Mix well.

**Caution:** Concentrated sulphuric acid is hygroscopic and highly corrosive, therefore do not mouth pipette, and never add the water to the acid.

- 2 Prepare a 1% w/v solution of barium chloride by dissolving 0.5 g of dihydrate barium chloride ( $\text{BaCl}_2 \cdot 2\text{H}_2\text{O}$ ) in 50 ml of distilled water.

- 3 Add 0.6 ml of the barium chloride solution to 99.4 ml of the sulphuric acid solution, and mix.

- 4 Transfer a small volume of the turbid solution to a capped tube or screw-cap bottle of the same type as used for preparing the test and control inocula.

When stored in a well-sealed container in the dark at room temperature (20–28 °C), the standard can be kept for up to 6 months.

*Control strains*

Control strains are used to test the performance of the method. The following strains of bacterial species are recommended.

- *Staphylococcus aureus* ATCC 25923.
- *Escherichia coli* ATCC 25922.
- *Pseudomonas aeruginosa* ATCC 27853.

**Sources of control strains**

Reference Laboratories should supply local laboratories.

The control strains should be grown on slopes of nutrient agar or tryptone soya agar and stored refrigerated at 2–8 °C. They should be subcultured every 3–6 months. At the beginning of each week a nutrient broth or agar culture should be prepared for daily use.

**Method**

- 1 Using a sterile wire loop, touch 3–5 well-isolated colonies of similar appearance to the test organism and emulsify in 3–4 ml of sterile physiological saline or nutrient broth.
- 2 In a good light match the turbidity of the suspension to the turbidity standard (mix the standard immediately before use). When comparing turbidities it is easier to view against a printed card or sheet of paper (see Plate 7.21).
- 3 Using a sterile swab, inoculate a plate of Mueller Hinton agar. Remove excess fluid by pressing and rotating the swab against the side of the tube above the level of the suspension (see Plate 7.22).  
Streak the swab evenly over the surface of the medium in three directions, rotating the plate approximately 60° to ensure even distribution (see Plate 7.23).
- 4 With the petri dish lid in place, allow 3–5 minutes (*no longer than 15 minutes*) for the surface of the agar to dry.
- 5 Using sterile forceps, needle mounted in a holder, or a multidisc dispenser, place the appropriate antimicrobial discs, evenly distributed on the inoculated plate (see Plate 7.24). Using a template as shown in Plate 7.26 will help to ensure the discs are correctly placed.

*Note:* The discs should be about 15 mm from the edge of the plate and no closer than about 25 mm from disc to disc. No more than 6 discs should be applied (90 mm dish). Each disc

should be lightly pressed down to ensure its contact with the agar. It should not be moved once in place.

- 6 Within 30 minutes of applying the discs, invert the plate and incubate it aerobically at 35 °C for 16–18 h (temperatures over 35 °C invalidate results for oxacillin).
- 7 After overnight incubation, examine the control and test plates to ensure the growth is confluent or near confluent. Using a ruler on the underside of the plate measure the diameter of each zone of inhibition in mm. The endpoint of inhibition is where growth starts.

*Sulphonamides and co-trimoxazole*

Ignore any slight growth within the inhibition area.

*Beta-lactamase producing staphylococci*

A zone of inhibition can be formed by penicillin-resistant staphylococci when the amount of beta-lactamase (penicillinase) is insufficient to inactivate the penicillin close to the disc. Such a zone, however, has a heaped up clearly defined edge with no gradual fading away of growth towards the disc as seen with susceptible strains. Colonies may sometimes be seen growing within the inhibition zone. Report all strains showing a heaped up zone edge, regardless of the size of the inhibition zone, as '*Resistant*'.

*Proteus strains*

Some *Proteus* strains may swarm into the area of inhibition but the actual zone of inhibition is usually clearly outlined.

**Interpretation of zone sizes**

Using the Interpretative Chart, interpret the zones sizes of each antimicrobial, reporting the organism as '*Resistant*', '*Intermediate/Moderately susceptible*', '*Susceptible*'.

*Resistant:* A pathogen reported as '*resistant*' implies that the infection it has caused will not respond to treatment with the drug to which it is resistant irrespective of dose or site of infection.

*Intermediate:* A pathogen reported as intermediately susceptible suggests that the infection it has caused is likely to respond to treatment when the drug is used in larger doses than normal or when the drug is concentrated at the site of infection, e.g. in the urinary tract. Consideration should be given to using other drugs that may provide more optimal therapy.

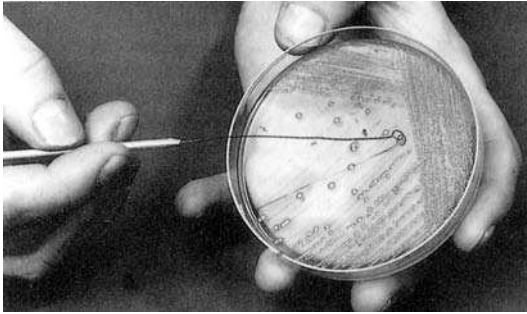

Plate 7.20 Removing colonies from a primary culture plate to make a suspension of the test organism.

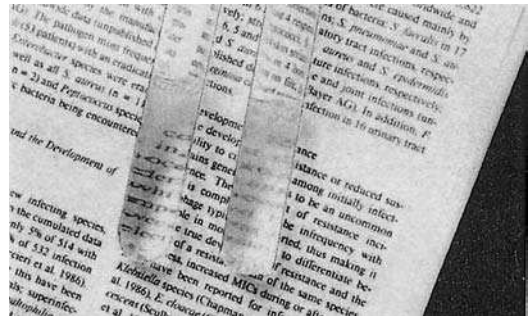

Plate 7.21 Checking the turbidity of the test suspension against the turbidity of a chemical standard.

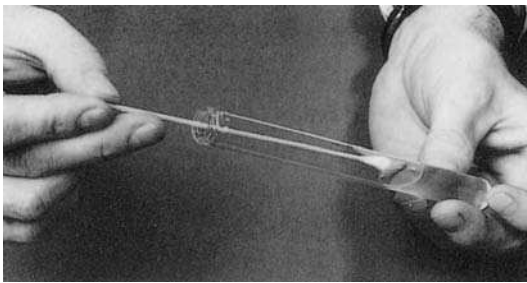

Plate 7.22 Avoiding using too much inoculum by pressing and rotating the swab against the side of the tube.

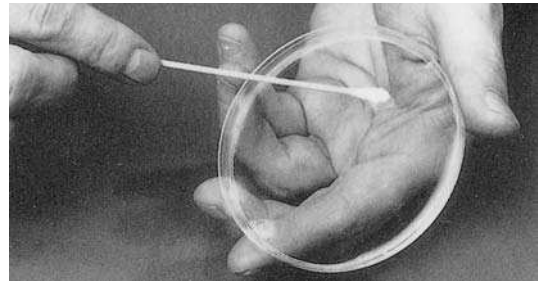

Plate 7.23 Swabbing the surface of the susceptibility testing agar. The plate is swabbed in three directions, rotating the plate approximately 60° to ensure even distribution.

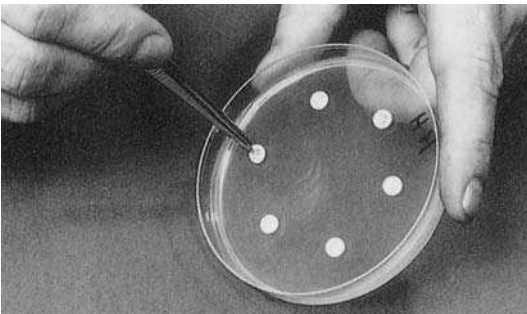

Plate 7.24 Placing antimicrobial discs on the inoculated plate.

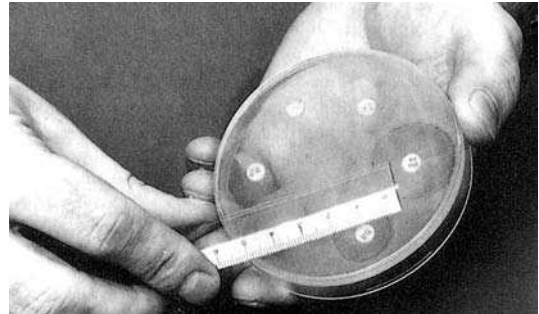

Plate 7.25 Measuring the zones of inhibition in mm. The end of inhibition is where growth starts.

*Acknowledgement:* Plates 7.20–7.25 have been reproduced from *Basic laboratory procedures in clinical bacteriology*, WHO, 2nd edition, 2003 by permission of the World Health Organization.

**Susceptible:** A pathogen reported as susceptible suggests that the infection it has caused is likely to respond to treatment when the drug to which it is susceptible is used in normal recommended doses and administered by an appropriate route.

**Note:** It is usually only necessary to report the first and second choice antibiotics for a patient's infection, unless the strain is resistant. Always use generic names of antibiotics, not trade names, in laboratory reports.

### Quality control when performing Kirby-Bauer disc diffusion technique

- Purchase Mueller Hinton agar from a reliable source. Check its pH. Ensure plates contain the correct amount of agar. Check new batches using *E. faecalis* control strain (ATCC 29212 or 33186) and co-trimoxazole disc.
- Prepare carefully the inoculum of the test and control organisms to ensure growth is confluent. Renew the turbidity standard every few months.
- Use discs containing the correct amount of antimicrobial. Store discs correctly and do not use them beyond their expiry date. Alternatively, use stable antimicrobial tablets (see previous text).
- Place discs or tablets correctly on the plate, not too close to each other or to the rim of the plate.
- Use appropriate control strains.

- Regularly check the temperature of the incubator to ensure tests are incubated at 35 °C.
- Measure inhibition zones carefully.
- Zone diameters with control strains should be within the limits published by NCCLS.

### *Etest*

Confirmation of unusual resistance profiles can be performed using the *Etest* method. *Etest* is a quantitative technique for the determination of minimum inhibitory concentration (MIC) of antimicrobial agents against microorganisms and detection of resistance mechanisms. It comprises a predefined gradient of antibiotic concentration for a specific antibiotic on a plastic strip.

When the *Etest* strip is applied onto an inoculated agar surface, eg Mueller Hinton, the gradient of antimicrobial agent is transferred immediately to the medium. After overnight incubation or longer, a symmetrical inhibition elipse (elliptical shaped zone) centred along the strip is formed. The MIC is read directly from the scale in micrograms per millilitre ( $\mu\text{g/ml}$ ) at the point where the inhibition elipse edge intersects the strip.

Colour illustrations of the results of different antibiotic *Etests*, detailed instructions on how to use an *Etest* strip,

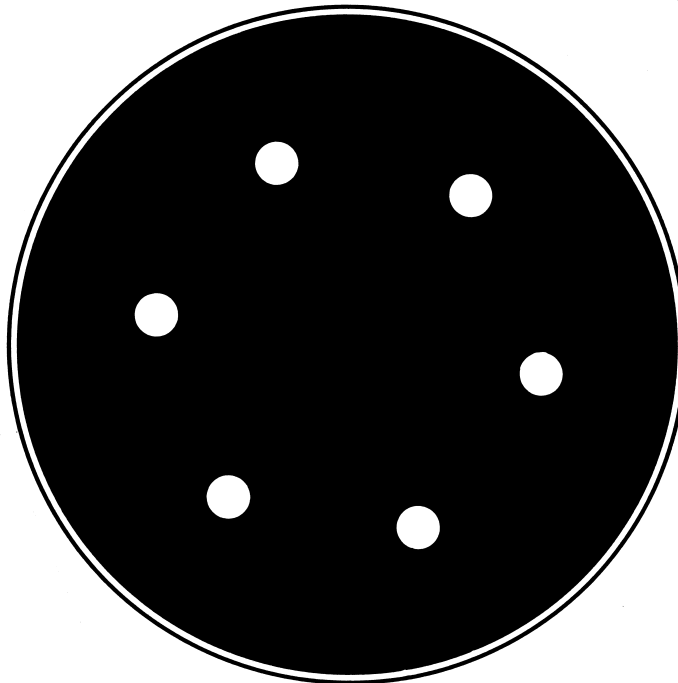

Plate 7.26 Template for applying antimicrobial discs (90 mm diameter petri dish).

**Interpretative chart of zone sizes** – The values given in the table below refer to the Kirby-Bauer technique

Antimicrobial agent	Disc potency	Diameter of zone of inhibition (mm)		
		Susceptible	Intermediate	Resistant
<b><math>\beta</math>-Lactams</b>				
● ampicillin when testing:				
enterococci	10 $\mu$ g	$\geq 17$	–	$\leq 16$
Gram-negative organisms	10 $\mu$ g	$\geq 17$	14–16	$\leq 13$
<i>Haemophilus</i> spp.	10 $\mu$ g	$\geq 22$	19–21	$\leq 18$
● benzylpenicillin when testing:				
<i>N. gonorrhoeae</i> <sup>1,2</sup>	10 IU	$\geq 47$	27–46	$\leq 26$
staphylococci	10 IU	$\geq 29$	–	$\leq 28$
● cefazolin <sup>3</sup>	30 $\mu$ g	$\geq 18$	15–17	$\leq 14$
● cefotaxime <sup>3</sup>	30 $\mu$ g	$\geq 23$	15–22	$\leq 14$
● ceftazidime <sup>3</sup>	30 $\mu$ g	$\geq 18$	15–17	$\leq 14$
● ceftriaxone <sup>3</sup> when testing <i>N. gonorrhoeae</i> <sup>4,5</sup>	30 $\mu$ g	$\geq 35$	–	–
● oxacillin <sup>6</sup> when testing:				
<i>Streptococcus pneumoniae</i> for penicillin susceptibility <sup>4</sup>	1 $\mu$ g	$\geq 20$	–	–
staphylococci	1 $\mu$ g	$\geq 13$	11–12	$\leq 10$
● piperacillin when testing <i>P. aeruginosa</i>	100 $\mu$ g	$\geq 18$	–	$\leq 17$
<b>Quinolones</b>				
● ciprofloxacin when testing:				
Gram-negative enteric bacilli	5 $\mu$ g	$\geq 21$	16–20	$\leq 15$
<i>N. gonorrhoeae</i> <sup>4</sup>	5 $\mu$ g	$\geq 41$	28–40	$\leq 27$
● nalidixic acid	30 $\mu$ g	$\geq 19$	14–18	$\leq 13$
<b>Other drugs</b>				
● chloramphenicol when testing:				
Gram-negative enteric bacilli	30 $\mu$ g	$\geq 18$	13–17	$\leq 12$
<i>Haemophilus</i> spp. <sup>4</sup>	30 $\mu$ g	$\geq 29$	26–28	$\leq 25$
<i>S. pneumoniae</i> <sup>4,7</sup>	30 $\mu$ g	$\geq 21$	–	$\leq 20$
● erythromycin	15 $\mu$ g	$\geq 23$	14–22	$\leq 13$
● gentamicin <sup>8</sup>	10 $\mu$ g	$\geq 15$	13–14	$\leq 12$
● nitrofurantoin <sup>9</sup>	300 $\mu$ g	$\geq 17$	15–16	$\leq 14$
● sulfonamides	300 $\mu$ g	$\geq 17$	13–16	$\leq 12$
● tetracycline when testing:				
Gram-negative enteric bacilli	30 $\mu$ g	$\geq 19$	15–18	$\leq 14$
<i>N. gonorrhoeae</i> <sup>1,2</sup>	30 $\mu$ g	$\geq 38$	31–37	$\leq 30$
● trimethoprim	5 $\mu$ g	$\geq 16$	11–15	$\leq 10$
● trimethoprim + sulfamethoxazole (co-trimoxazole)	1.25 $\mu$ g + 23.75 $\mu$ g	$\geq 16$	11–15	$\leq 10$
● vancomycin when testing:				
enterococci	30 $\mu$ g	$\geq 17$	15–16	$\leq 14$
other Gram-positive organisms <sup>4</sup>	30 $\mu$ g	$\geq 15$	–	–

### Notes

- 1 An intermediate category for *N. gonorrhoeae* indicates a lower cure rate (85–95%) among infected patients compared to more than 95% cure rates for susceptible strains.
- 2 Gonococci with 10 IU penicillin disc zones of  $\leq 19$  mm are likely to be  $\beta$ -lactamase producers. With tetracycline 30- $\mu$ g discs, zone diameters of  $\leq 19$  mm usually indicate a plasmid-mediated tetracycline-resistant *N. gonorrhoeae* (TRNG) strain (MIC correlate  $\geq 16$  mg/l).
- 3 Choices for cephalosporin surveillance testing: cephalothin represents the group cephalothin, cephalexin and cefadroxil, while cefazolin represents cefazolin and cefaclor. Ceftazidime maximizes recognition of extended spectrum  $\beta$ -lactamase-mediated resistance; cefotaxime is used for testing against salmonellae; and ceftriaxone is a reserve antimicrobial used for gonococcal testing only.

- 4 Strains yielding zone diameter results suggestive of a non-susceptible category should be submitted to a central reference laboratory for further testing.
- 5 For these drugs, the current rarity of well documented resistant strains precludes the definition of any category other than susceptible.
- 6 Oxacillin (representing the group oxacillin, nafcillin, cloxacillin, dicloxacillin and flucloxacillin) is used in testing because of its greater resistance to deterioration during storage and its application to antimicrobial susceptibility testing of *S. pneumoniae*. Oxacillin resistance among staphylococci implies resistance to all  $\beta$ -lactams (penicillins, cephalosporins, carbapenems and  $\beta$ -lactamase inhibitor combinations).
- 7 The criteria utilized by the NCCLS have been modified for use in laboratories in developing countries, e.g. no intermediate category.
- 8 Testing for high-level aminoglycoside resistance should be performed by the agar dilution method (brain-heart infusion or BHI medium) with a screening concentration of 500 mg of gentamicin per litre. Alternatively, antimicrobial discs containing high levels of gentamicin ( $\geq 120 \mu\text{g}$ ) may be available for this purpose in some areas.
- 9 Used to predict susceptibility to furazolidone.

*Acknowledgement:* The above Chart is reproduced from *Sixth Report of the WHO Expert Committee – The Use of Essential Drugs* updated according to current NCCLS Standards: *Performance Standards for Antimicrobial Disk Susceptibility Tests – Sixth Edition, 1997; Approved Standard, as supplemented in M100-S9 Performance Standards for Antimicrobial Susceptibility Testing: Ninth Informational Supplement.*

- **Important:** Future updates can be obtained from NCCLS, 940 West Valley Road, Suite 1400, Wayne, PA 19087–1898, USA. E-mail exoffice@nccls.org
- Interpretation of zone sizes for additional antimicrobials can be found on p. 116 in *Basic Laboratory procedures in clinical bacteriology* (see Further information).

storage instructions, and cost of the strips can be obtained from the website of the manufacturer, AB Biodisk, www.abiodisk.com. Other contact details for AB Biodisk can be found in Appendix 11. Further information on the use of *Etest* strips can be found in the publication *Manual for the laboratory identification and antimicrobial susceptibility testing of bacterial pathogens of public health importance in the developing world* (see Further information).

### Nitrocefin test to detect *beta*-lactamase enzymes

The nitrocefin biochemical test is a sensitive technique for detecting *beta*-lactamase producing strains of *N. gonorrhoeae*, *H. influenzae* and *M. catarrhalis*. Nitrocefin is a chromogenic cephalosporin which changes from yellow to red when its *beta*-lactam ring is hydrolyzed by *beta*-lactamase.

Although the test can be performed using a nitrocefin solution, nitrocefin is very expensive, light-sensitive, and not easily obtained. Most laboratories find it more convenient to use a commercially available nitrocefin test such as the *Oxoid beta-lactamase (nitrocefin) Touch Stick*, code number BR0066A. Each pack contains 100 sticks. When stored frozen (below  $-10^\circ\text{C}$ ) the sticks have a shelf-life of about 1 year. The test is performed by touching a colony of the test organism with a stick and when the organism is *beta*-lactamase producing, the end of the stick turns pink-red within 15 minutes (usually within a few minutes). The reaction is shown in colour Plate 51.

### Acidimetric test to detect *beta*-lactamase producing strains of *N. gonorrhoeae* and *H. influenzae*

When it is not possible to obtain the products to perform a nitrocefin test, a simple acidimetric test can be used to detect *beta*-lactamase producing strains of *N. gonorrhoeae* and *H. influenzae*. The test is not sufficiently sensitive to detect *beta*-lactamases producing strains of *M. catarrhalis*. The acidimetric test is based on detecting a change in colour of the indicator bromocresol purple from purple to yellow due to penicilloic acid produced from the breakdown of penicillin (used in the test) by *beta*-lactamase.

### Method

- 1 Place a strip of Whatman No. 1 filter paper in the bottom of a petri dish. Add a few drops of buffered crystalline penicillin bromocresol purple solution\* until the paper is almost saturated.

\*Prepare as described in Reagent No. 29. Alternatively, use inexpensive Rosco Diagnostica *Beta*-lactamase acidimetric tablets, code 455-21 which can be purchased in packs of 25 tablets.

- 2 Using a sterile wire loop or stick, spread the growth from 10–20 colonies of the test organism on the filter paper, covering an area approximately 5 mm in diameter.

*Controls:* Test also a known positive and negative *beta*-lactamase producing organism.

- 3 Replace the lid of the petri dish and incubate the test at room temperature for up to 30 minutes.
- 4 Examine the filter-paper spots for a change in colour from purple-blue to yellow.

**Yellow colour:** Report the test as '*Beta*-lactamase producing organism'.

**Purple colour (no change):** Report the test as '*Non-beta*-lactamase producing organism'.

*Note:* The above reactions are shown in colour Plate 50.

#### REFERENCES

- 1 **Ibeawuchi R, Mbata IT.** Rational and irrational use of antibiotics. *Africa Health*, January, 2002.
- 2 **Okeke IN.** Antibiotic resistance in Africa: Discerning the enemy and plotting a defence. *Africa Health*, March, 2003.

#### FURTHER INFORMATION

**Vandepitte J et al.** *Basic laboratory procedures in clinical bacteriology*. WHO, Geneva, 2nd edition 2003.

**Perilla MJ et al.** *Manual for the laboratory identification and antimicrobial susceptibility testing of bacterial pathogens of public health importance in the developing world*. CDC, WHO, 2003. Availability: e-mail cdsdoc@who.int or Fax +1 404 639 3970.

**Collins CH et al.** *Collins and Lyne's Microbiological Methods*, 8th edition, 2004. Arnold publishers.

**World Health Organization.** *Prevention of hospital-acquired infections*, 2nd edition, 2002.

## 7.17 Water-related diseases and testing of water supplies

Globally over one billion people have no access to safe drinking water and 2.6 billion lack adequate sanitation. This leads to 1.8 million people dying every year from water and sanitation related diarrhoeal diseases, 90% being children under 5 years, mostly in developing countries (WHO 2004 figures). Growth and nutrition in young children are also adversely affected by contaminated water supplies, poor hygiene and inadequate sewerage. The United Nations has declared 2005–2015 the *Water for Life Decade* with a focus on water-related issues and a goal of halving by 2015 the number of people with no access to sustainable safe drinking water and basic acceptable sanitation.

**Issues identified as priority for the Decade:** These include: water scarcity, sanitation access, disaster prevention, trans-boundary water issues, gender issues, capacity-building, financing, valuation, integrated water resources management, environment and biodiversity, food and agriculture, pollution and energy.

### Water and health

Many water sources in developing countries are unhealthy because they contain harmful physical, chemical, and biological agents. To maintain good health, however, not only must a water supply be *safe to drink*, it must also be:

- available in sufficient quantity for cooking, hand-washing, personal bathing, cleaning and laundering clothes,
- easily and safely accessible by all the community without the need to carry heavy containers of water over long distances or having to visit sites where insect vectors of disease breed,
- available all of the time or when it is needed,
- available at affordable cost.

It should also meet local standards for taste, odour, and appearance.

#### Examples

- A project that improves the water in public standpipes in a village will do little good if most people live so far away that they prefer to use polluted water from a nearby river.
- Similarly, a water supply situation will not be improved when accessible standpipes are installed but they only have water in the mornings, resulting in people either storing the water (increasing the risk of contamination) or collecting water in the afternoon from other less safe sources.

Health education is required to explain the relationship between health, water, sanitation and hygiene. Community involvement is essential to protect water supplies from pollution and to perform basic surveillance and maintenance of water and sanitation systems.

### Transmission of infectious water-related diseases

Most of the mortality and morbidity associated with water-related disease in developing countries is due directly or indirectly to infectious agents. The four main routes by which water-related infections are transmitted are as follows:

- *Water-borne route* in which humans become infected by ingesting pathogenic bacteria, viruses, or parasites in water polluted by human or animal faeces or urine.

**Examples of water-borne diseases**

<i>Bacterial</i>	<i>Parasitic</i>
Cholera	Amoebic dysentery
Bacillary dysentery (shigellosis)	Cryptosporidiosis
Typhoid	Giardiasis
Paratyphoid	Balantidiasis
Salmonellosis	<i>Viral</i>
<i>Campylobacter</i> enteritis	Rotavirus diarrhoea
<i>E. coli</i> diarrhoea	Hepatitis A
Leptospirosis	Poliomyelitis

All water-borne diseases can also be transmitted by other faecal-oral routes, e.g. ingestion of faecal contaminated food. Control is by preventing water supplies becoming contaminated by human or animal faeces or raw sewage entering a water supply, e.g. during times of flooding.

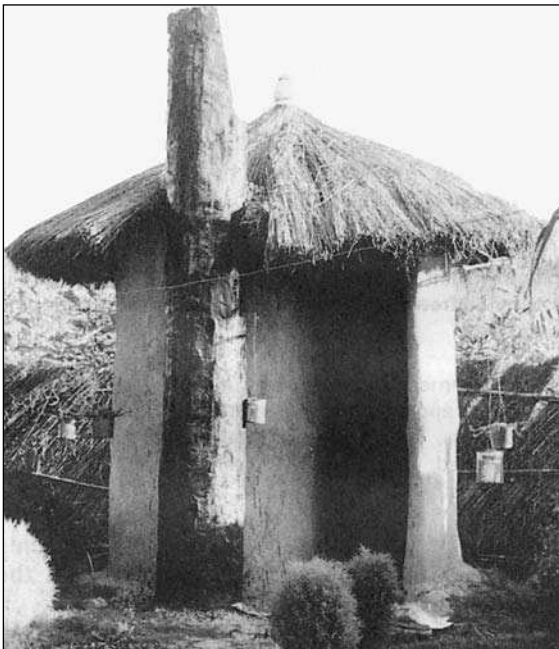

Plate 7.27 Ventilated improved pit (VIP) latrine of spiral design, built of mud and wattle. The vent pipe is made from a rolled up reed mat and has a flyscreen.  
*Courtesy of Professor Duncan Mara.*

- *Water-washed route* in which disease is associated with a scarcity of water for personal hygiene (bathing, handwashing), laundering clothes, cleaning of cooking utensils.

**Examples of water-washed diseases**

<i>Skin diseases</i>	<i>Louse-borne</i>
Scabies	Typhus
Yaws	Relapsing fever
Impetigo	<i>Faecal-oral diseases</i>
Skin ulcers	See list under Water-borne diseases

*Eye diseases*

Trachoma  
Conjunctivitis

- *Water-based route* which involves parasites that require a snail host, fish, or other aquatic animal in which to develop. Humans become infected by ingesting the infective forms or by the infective forms penetrating the skin.

**Examples of water-based parasitic infections***Infective forms penetrate skin*

Schistosomiasis (cercariae released from snail, penetrate skin).

*Infective forms ingested*

Dracunculiasis (larvae ingested in crustacean)

Paragonimiasis (metacercariae ingested in crab or crayfish)

Clonorchiasis (metacercariae ingested in fish).

- *Insect vector route* in which humans become infected by being bitten by an insect vector which breeds in or around water.

**Examples of water-related insect-transmitted infections***Mosquito-borne*

Malaria

Filariasis

Dengue

Yellow fever

*Other insects*

Trypanosomiasis (riverine tsetse flies)

Onchocerciasis (blackflies)

**Further information:** Readers are referred to Chapter 7: Microbial aspects, in WHO *Guidelines for drinking water quality*, 3rd edition, Vol. 1, 2004.

**WATER SUPPLY SURVEILLANCE**

WHO defines water supply surveillance as 'keeping a careful watch at all times, from the public health point of view, over the safety and acceptability of drinking water supplies'. It involves two complementary activities:

- Sanitary inspection
- Water quality analysis

**Sanitary inspection**

This is a systematic inspection of an installation or water supply system with the objectives of identifying potential risks of contamination and any sources of pollution, and recommending appropriate remedial measures. What is included in the sanitary inspection will depend on the type of system or installation, e.g. a well, borehole, spring, or piped water supply. Appropriate, easy to understand comprehensive forms should be used to help those carrying out the inspection and those responsible for deciding what action(s) to take. The following is an example of a sanitary inspection form for a distribution network.





Plate 7.28 Protected well-maintained water supply, providing safe water. *Courtesy of J Holmes, WaterAid.*



Plate 7.29 Demonstrating washing of hands to prevent the ingestion of pathogens. It is estimated that hand washing and hygiene education lead to a 45% reduction in diarrhoeal diseases. *Courtesy of World Health Organization. Photo: D Henrioud.*

*Note:* Detailed information on how to carry out sanitary inspections and examples of forms for inspecting wells (dug and tubewells), boreholes, spring water systems and rainwater tank catchments can be found in the publications, *Drinking water quality in rural areas* and *WHO Guidelines for drinking water quality: Volume 111 Surveillance and control of community water supplies*.

**Example of a sanitary inspection form for a distribution network**

Community \_\_\_\_\_ Department \_\_\_\_\_

Date \_\_\_\_/\_\_\_\_/\_\_\_\_ Water sample result \_\_\_\_\_

- |   |   |        |
|---|---|--------|
| 1 | Is there any point of leakage between source and reservoir? | Yes/No |
| 2 | If there are any, are their covers insanitary?              | Yes/No |

*If there is a reservoir:*

- |    |   |        |
|----|---|--------|
| 3  | Is the inspection cover or roof insanitary?   | Yes/No |
| 4  | Are any air vents insanitary?   | Yes/No |
| 5  | Is the reservoir cracked or leaking?  | Yes/No |
| 6  | Are there any leaks in the distribution network?  | Yes/No |
| 7  | Is there any sanitation within 10 metres of the pipeline (e.g. latrines, sewers, septic tanks or burial grounds?) | Yes/No |
| 8  | Does water accumulate near tap-stands?  | Yes/No |
| 9  | Is the plinth cracked or eroded?  | Yes/No |
| 10 | Does the tap leak?  | Yes/No |

**Sanitary risk score** \_\_\_\_\_/10

All the 'Yes' answers are added up to give a sanitary risk score out of 10

**Recommendations:** \_\_\_\_\_

*Reproduced with permission from Africa Health. Original Andy Rickards and Jamie Bartram.*

*Note:* A sanitary inspection cannot identify all sources of contamination (e.g. leaking pipes or well-linings), but it can help to identify the source(s) and point of entry of contamination which might be missed by water quality analysis alone. It can help to identify potential problems before they cause contamination, often preventing the need for costly remedial work at a later stage. An inspection can check the proximity of a water supply to sources of pollution, e.g. latrines or refuse collection points. The importance of inspecting a water supply is illustrated in the following examples.

**Examples**

- Water from a well supplying a small community was shown to be heavily contaminated. When the site was inspected the sources of the contamination were obvious. The well was badly protected, with pigs, chickens and donkeys allowed around the well. There was no

handpump. A bucket and rope used to collect the water was left on the muddy ground and spilt water seeped back into the well taking with it surface contamination. There was no concrete slab around the well (sloping away from it).

- A village is supplied with water from a large distribution network. The water coming from the outside taps of the houses was found to be of excellent quality, but many children had diarrhoeal disease. Investigation of the water supply found that each morning the water source was being diverted, cutting off the supply to villagers' homes. To ensure water was available, each evening the villagers collected the water in open containers. From these, animals were allowed to drink and scoops used to transfer the water were left on the ground. The water became contaminated and children and sometimes adults drinking from this stored contaminated water became sick.

**Water quality analysis**

Although water can contain unwanted chemicals (from natural sources and agricultural activities), the greatest risk to human health is from faecal contamination of water supplies (see previous text, *Water-borne diseases*). Serious ill health can be caused by water becoming contaminated from faeces being passed or washed into rivers, streams or pools or being allowed to seep into wells or boreholes. The most important aspect of analysis is therefore to determine whether faecal contamination is present.

The bacteriological analysis of water can confirm whether a water supply has been faecally contaminated. In piped water distribution systems, a sanitary inspection will often not detect problems occurring during distribution, e.g. pipes buried underground might be damaged, allowing in pollution. Analysis is also used to check the effectiveness of disinfection processes. It is also a useful way of keeping communities interested in their water supplies and justifying requests to health authorities for improvements in water quality.

Testing for the presence of normal faecal organisms in water is a way of determining whether a water supply is faecally polluted. To search directly in water samples for the presence of specific enteric pathogens is impractical for routine control purposes. When no normal faecal bacteria are detected in a water sample, it is probable that enteric pathogens (usually present in much smaller numbers) are also absent. It must be remembered, however, that some viruses and parasites survive longer and are more resistant to chlorination than some faecal bacteria used as indicators of pollution.

Faecal coliforms (sometimes called thermotolerant coliform organisms, or *E. coli*)\* are the most appropriate indicators of faecal pollution. It is less useful to test for 'total coliforms' because they are

not directly related to the presence of faecal contamination and so not to the risk of disease. The most valuable test for the routine quality control of water supplies is the *E. coli* count (described later in the text).

\*'Coliform organisms' refer to Gram negative, oxidase-negative, non-sporing rods capable of growing aerobically on an agar medium containing bile salts, and able to ferment lactose within 48 hours at 35–37°C with the production of both acid and gas.

*E. coli* is a coliform organism capable of fermenting lactose with the production of acid and gas at 35–37°C and 44°C (thermotolerant). Other characteristics of *E. coli* are described in subunit 7.18.14.

*Note:* Examination of water for faecal streptococci and clostridia may sometimes be of value in confirming the faecal nature of pollution in doubtful cases.

### **Other tests used in water quality analysis**

These may include:

- Testing chlorine treated water supplies for free residual chlorine (mg/l) to assess the effectiveness of disinfection (see later text).
- Measuring the pH of the water. The pH can affect the efficiency of chlorine disinfection. Chlorination is more effective at a pH below 7.0 (and at higher temperatures). The pH of water can be tested using pH papers.
- Testing for turbidity or cloudiness of the water which can be important in determining whether a water supply is acceptable (see later text).

### **Collection of samples for water analysis**

Samples of water for bacteriological testing must be collected in sterile bottles and care *must* be taken to prevent accidental contamination of the water during its collection.

#### **Sampling bottles**

Glass bottles used for water sampling should have a capacity of at least 200 ml. They should be fitted with ground glass stoppers or screw caps. The stopper or cap and neck of the bottle should be protected from contamination by a suitable cover either of paper or thin aluminium foil. Silicon rubber liners, that will withstand repeated sterilization at 160°C, should be used inside screw caps. After being sterilized the bottle should not be opened before the sample is collected.

#### *Neutralizing chlorine in water samples*

When the water to be examined is likely to contain chlorine or chloramine, sufficient sodium thiosulphate ( $\text{Na}_2\text{S}_2\text{O}_3 \cdot 5\text{H}_2\text{O}$ ) to neutralize these substances must be added to each bottle as follows:

Add 100–200  $\mu\text{l}$  (0.1–0.2 ml) sodium thiosulphate

30 g/l (3% w/v) to each bottle of 200 ml capacity before it is sterilized. This will give a concentration of approximately 18 mg/litre of water.

*Note:* Sodium thiosulphate at a concentration of approx. 18 mg/litre has no significant effect on the coliform or *E. coli* content of a water sample. It should neutralize up to 5 mg/litre of residual chlorine.

#### *Information to be supplied with water samples*

Each water sample should be given a code number and the following information should accompany the sample (preferably using a standardized form):

- Reasons for examination, e.g. whether a routine sample or otherwise.
- Source from where the water has been collected, e.g. whether from a well, spring, lake, reservoir, or piped supply. The exact place from where the water was taken should also be stated.
- State whether the water has been filtered, chlorinated, or treated in some other way.
- *Sample from a house tap:* Mention whether the water was drawn from a cistern or direct from the main.

*Sample from a well:* Give details of the well's depth, whether covered or uncovered, and whether recently constructed or altered.

*Sample from a spring:* Describe the stratum from which it issued and whether the sample was taken directly from spring or from a collecting chamber.

*Sample from a river or stream:* Mention the depth at which the sample was collected, whether from the side or the middle of the stream, whether the water level was above or below average, and whether there had been heavy rainfall or flooding.

*Sample from a lake or reservoir:* Give the exact position and the depth at which it was collected.

- Temperature of the source of the sample.
- Mention any possible sources of pollution in the area and their approximate distance from the sampling point.
- Date and time when the sample was taken (and dispatched if sent to a testing laboratory). Whenever possible water samples should be processed in the field.

#### **Sampling**

Hold the sterile bottle by the base in one hand. Use the other hand to remove the stopper and cover together. The stopper and cover should be retained in the hand while the bottle is filled and then they

should be replaced together. To prevent contamination, the person collecting the water must not touch, or allow any surface to touch, the screw thread of the bottle neck or the inside of the cap. If the bottle becomes contaminated, it must not be used.

#### Collecting a sample from a tap

- 1 Remove any external fittings from the tap, such as an anti-splash nozzle or rubber tube.
- 2 Clean carefully the outside nozzle of the tap, especially any grease which has collected.
- 3 Turn the tap on full, and allow the water to run to waste for 1 minute. This allows time for the nozzle of the tap to be flushed and any stagnant water in the service pipe to be discharged.
- 4 Sterilize the tap using the flame of a blowlamp or gas torch, or by igniting a piece of cotton-wool soaked in methylated spirit and holding it with a pair of tongs close to the nozzle until the whole tap is unbearably hot to the touch.
- 5 Allow the tap to cool by running the water to waste for a few seconds.
- 6 Fill the sample bottle from a gentle flow of water, and replace the cap of the bottle.
- 7 Using a water-proof marker or grease pencil, number the bottle with the sample code number.

*Note:* Leaking taps may cause contamination of the sample from sources outside the water pipe and therefore leaks

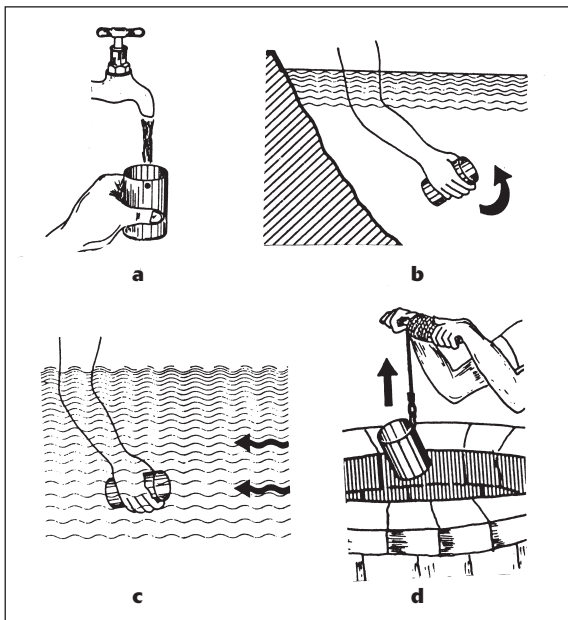

Fig 7.23 Water sampling techniques (a) Taking a sample from a tap. (b) Sampling from a lake, reservoir or other surface water source. (c) Taking a sample from a river or stream (against the current flow). (d) Sampling from a well or tank (not allowing the cup to touch the walls). *Courtesy of Robens Centre for Public and Environmental Health.*

should be reported when sampling. A bacteriological sample should not be taken until the leak is repaired.

#### Collecting a sample from a street hydrant

Collect a sample from a suitable tap supplying water direct from the main. Where this is not possible, obtain a sample from a street hydrant by the following method:

- 1 Pour hypochlorite solution (5–10% v/v) into the duckfoot or hydrant bowl. If the hydrant box is full of water it must be baled out until 1 inch below the top of the duckfoot or bowl and enough water must be displaced to allow room for the hypochlorite solution.
- 2 Immediately screw on the standpost with the bibcock shut.
- 3 Open the hydrant valve and bibcock until water runs, then shut the bibcock.
- 4 Allow at least one minute to elapse.
- 5 Open the bibcock fully and allow water to run for at least 2 minutes.  
*Caution:* Avoid being splashed by hypochlorite-charged water.
- 6 Make a residual chlorine test (see the end of this subunit) to make sure all the hypochlorite-charged water has been flushed to waste.
- 7 Screw down the bibcock to a small stream, and aseptically collect the sample.
- 8 Number the bottle with the sample code number.

#### Collecting a sample from a river, stream, or other surface water

- 1 Aseptically remove the cap and cover of the sterile sample bottle, and face the mouth of the bottle upstream (i.e. towards the flow of water).

*Note:* To avoid entering the water, the bottle should be clamped to the end of a stick. One way of doing this is to fix the bottle neck in a retort stand clamp and mount this on a stick.

- 2 Plunge the neck downwards about 30 cm below the water surface, and then tilt the neck slightly upwards to let it fill completely before carefully replacing the cap and cover.  
Where there is no current, push the bottle forward horizontally until it is filled.
- 3 Label the bottle with the sample code number.

#### Collecting a sample from a tubewell

- 1 Continuously operate the handpump for 5 minutes.
- 2 Heat the mouth of the pump, preferably by means of a blow lamp or gas torch, and pump several gallons of water to waste.
- 3 Aseptically collect a sample of water by allowing the water from the pump to flow directly into the sterile bottle. Carefully replace the bottle cap and cover.
- 4 Label the bottle with the sample code number.

#### Collecting a sample from an open well

If the well is one from which water can be raised only by means of a bucket and rope, use a weighted bottle to collect the sample as follows:

- 1 Tie a sterile sample bottle on to a weighted length of rope or strong string. Use a stone or heavy piece of metal as a

- weight, and attach the bottle just above the weight.
- 2 Aseptically remove the cap from the bottle, and lower the bottle into the well to a depth of about 1 metre.
  - 3 When no more air bubbles rise to the surface, raise the bottle out of the well and carefully replace the cap.
  - 4 Label the bottle with the sample code number.

#### *Transporting water samples to a water testing laboratory*

Immediately after collection, samples should be placed in an insulated cold box for transport to a water testing laboratory. Water samples should be examined as soon as possible on arrival and always within 6 hours of collection. Whenever possible, process water samples in the field.

#### **Frequency of sampling**

In large treatment plants, it should be a routine to sample water daily at each stage of treatment. In many tropical rural areas, however, untreated sources of water are used. In these situations, periodic sanitary surveys of the raw water should be carried out to establish the level of risk of epidemic water-borne disease to which the population is exposed.

The survey should include an on-site inspection and evaluation of the water supply system, and a bacteriological analysis of the water.

From such a survey, sources of pollution can often be identified and measures taken to prevent future contamination.

The frequency of sampling water in distribution pipes, unchlorinated water supplies before distribution, and chlorinated water before distribution is as follows:

#### *Water in distribution pipes*

It is inevitable that water quality deteriorates in distribution, mainly as a result of corrosion in pipes allowing leaks and infiltration.

The larger the population served, the longer is the distribution system and therefore the greater the risk of contamination.

At least one sample per 5000 population per month should be examined and every effort should be made to establish a random routine sampling procedure.

#### *Unchlorinated water supplies before distribution*

The World Health Organization has suggested that the maximum interval between successive samples for bacteriological analysis should be as follows:

<b>Population served</b>	<b>Maximum interval</b>
Less than 20 000 .....	1 month
20 000–50 000 .....	2 weeks
50 000–100 000 .....	4 days

#### *Chlorinated water supplies before distribution*

Large supplies, serving populations of greater than 100 000, should be subjected to daily sampling for bacteriological analysis in conjunction with continuous chlorine residual recording. The user of this book is more likely to be concerned with small rural supplies serving populations, often significantly less than 10 000, where even sampling for bacteriological analysis at weekly intervals may be impractical. In such cases it is important that the chlorine in water leaving treatment plants should be checked at least once daily (see later text).

---

#### **BACTERIOLOGICAL TESTING OF WATER**

As previously explained, the *E. coli* count is the most useful test for detecting faecal contamination of water supplies in water quality analysis. Two principal techniques are available for counting faecal coliforms:

##### ■ Membrane filtration

In this technique, a 100 ml water sample or a diluted sample is filtered through a membrane filter. The membrane, with the coliform organisms on it, is then cultured on a pad of sterile selective broth containing lactose and an indicator. After incubation, the number of coliform colonies can be counted. This gives the presumptive number of *E. coli* in the 100 ml water sample.

##### ■ Multiple tube/most probable number (MPN)

In this technique a 100 ml water sample is distributed (five 10 ml amounts and one 50 ml amount) in bottles of sterile selective culture broth containing lactose and an indicator. After incubation, the number of bottles in which lactose fermentation with acid and gas production has occurred are counted. The lactose is fermented by the coliforms in the water. By reference to probability tables (see later text), the most probable number of coliforms in the 100 ml water sample can be estimated.

#### **Choice of technique**

The membrane filtration technique is recommended for its accuracy, speed of result, and because it can be performed in the field. The membrane technique is significantly more accurate than the multiple tube technique, and this may be important when attempting to decide whether a slightly contaminated unchlorinated water source is fit for consumption. The multiple tube technique suffers from a large sampling error. Confidence limits for each technique are shown in the following table:

**Confidence limits\* for membrane filtration and multiple tube/MPN techniques**

Membrane colony count	Upper	Lower
1	5.6	0.025
5	11.7	1.6
10	18.4	4.8
100	124.0	78.0
Multiple tube MPN		
10	30.0	2.5
100	300.0	25.0

\*By confidence limits is meant the extent of uncertainty in the estimate. It provides an interval (upper and lower limit) which is likely to contain the true value.

Using the membrane technique, an *E. coli* colony count can be obtained in 12–18 hours and does not depend on the use of probability tables. The multiple tube/MPN technique requires up to 48 hours to obtain a presumptive *E. coli* count and biochemical confirmation may then be required.

The multiple tube/MPN technique is less expensive than the membrane technique although large quantities of culture media and glassware are required and also a relatively large capacity autoclave. For the filtration technique, smaller amounts of media and other laboratory-ware are used, but costly membrane filters are required. The membrane filtration technique is not suitable for turbid water samples due to membrane clogging.

**Membrane filtration technique****Required**

- Sterile filtration unit for holding 47 mm diameter membrane filters with suction device.

A metal unit that can be easily sterilized and used in the field or in the laboratory is shown in Fig. 7.24 and colour Plate 20. It is available from Wagtech International (see Appendix 11). Autoclavable plastic and glass filtration units are also suitable for laboratory use.

*Note:* When purchasing a filtration unit always buy a spare filter disk and gasket.

- Sterile grid membrane filters, 47 mm diameter with a pore size of 0.45 µm.

Membrane filters of the above specifications are available (200 per pack) from Wagtech International, Oxoid, and other suppliers.

- Sterile 47 mm diameter cellulose pads (broth culture medium is added just before use).

Available (200 per pack) from suppliers of membrane filters.

- Sterile petri dishes 50–60 mm diameter.

Aluminium dishes (50 mm diameter, 4 mm depth) are convenient for use. They can be sterilized by autoclaving, in a hot air oven, or by flaming. They are available from Wagtech International and other suppliers. Glass and plastic dishes are also available with a 50 mm or 60 mm diameter.

- Sterile membrane lauryl sulphate broth (lactose sodium lauryl sulphate broth). Allow 2.5 ml for each water sample. Prepare and autoclave as instructed by the manufacturer (do not use chlorinated water to prepare the medium). Store in amounts convenient for use (e.g. 20 ml per bottle). The sterilized medium has a shelf-life of 6 months when stored in a cool dark place. When lauryl sulphate broth is unavailable, use MacConkey membrane broth. *E. coli* colonies appear yellow on both types of broth.

Membrane lauryl sulphate broth and MacConkey membrane broth are available from Wagtech International, Oxoid, and other suppliers (small quantity packs are available from Wagtech).

For use, place a sterile cellulose pad in a sterile petri dish and add 2.5 ml of the sterile broth. The pad will swell slightly after adding the broth. Pour off any surplus broth before placing the membrane on the pad.

**Method (summarized in Fig. 7.24)**

- 1 Assemble the filtration unit and suction device (follow the instructions supplied with the unit).
- 2 Using sterile blunt-ended forceps, place a sterile membrane filter, grid-side uppermost, on the filter base (position it centrally), and reassemble the unit.

*Note:* In the field, metal forceps can be sterilized by dipping the tips in methylated spirit and flaming.

- 3 Mix *thoroughly* the sample of water by inverting the bottle several times.

**Volume of water to filter**

Treated water samples ..... 100 ml  
and groundwater samples

Untreated water samples ..... 10 ml\*  
from surface water source

Partially treated samples ..... 50 ml  
or protected borehole or well water ..... or 10 ml\*

\*The volume of water to use from untreated, partially treated and protected water supplies will depend on previous experience.

- 4 Apply suction (using hand, water, or electric device) to draw the water sample through the filter membrane.
- 5 Using sterile blunt-ended forceps, aseptically remove the membrane from the filtration unit

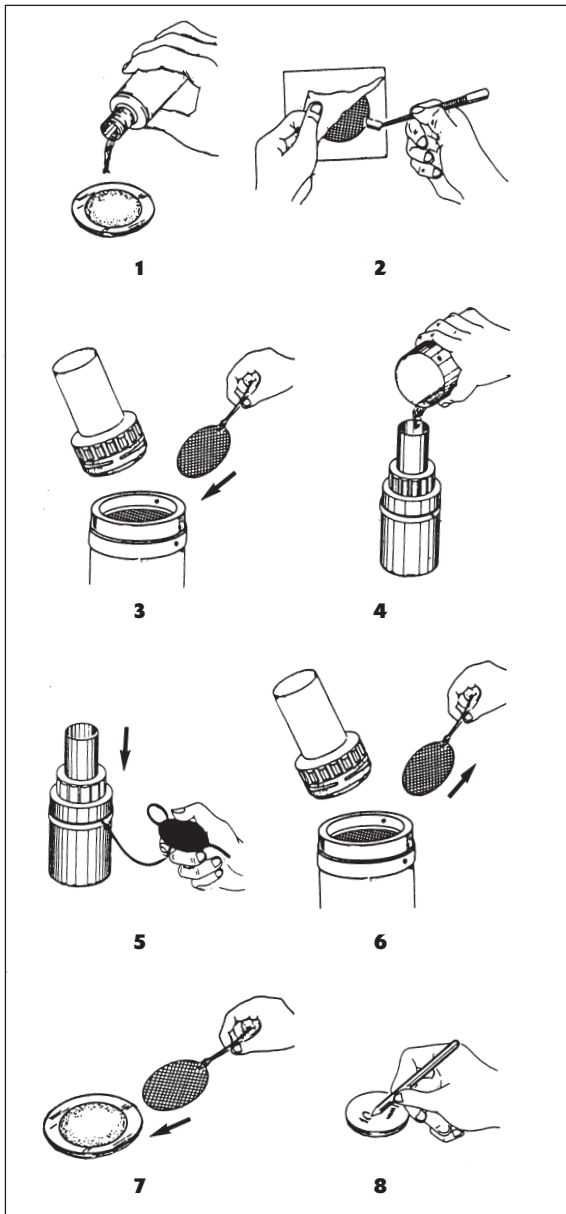

Fig 7.24 Microbiological testing of water by membrane filtration. **1** Adding sterile broth to the cellulose pad in a petri dish. **2** Aseptically removing the sterile membrane. **3** Placing the membrane on the filter base. **4** Pouring the water sample in the filter unit. **5** Drawing the water through the membrane by suction. **6** Removing the membrane. **7** Placing the membrane on the broth impregnated pad. **8** Labelling the petri dish before incubation. *Courtesy of Robens Centre for Public and Environmental Health.*

and place it, grid-side uppermost, on the culture medium pad in the petri dish, ensuring there are no air bubbles trapped under the membrane. Close the petri dish. Label the top of the lid with

the code number of the water sample and volume of water used.

- Leave at least 1 hour (4 hours for chlorinated samples) before incubating the sample(s) at 44 °C for 12–16 hours. Place the petri dishes (lids uppermost) in the incubator, preferably in a petri dish holder. When only a water bath is available, place the dishes in a leak-proof canister and incubate it at 44 °C for 12–16 hours, ensuring the canister is submerged in the water.

#### Battery and mains operated incubators

Portable incubators, measuring externally 310 × 155 × 168 mm, with a temperature range 25–45 °C, that can be operated from mains electricity (220V or 110V) and a 12V battery supply or only battery operated are manufactured by and available from Almedica (see Appendix 11). The *Cultura* battery/mains Almedica incubators are described and illustrated on p. 149 in Part 1 of the book.

A battery and mains operated incubator for use with a portable water testing kit is available from Wagtech International (see Appendix 11). A battery operated incubator also forms part of the DelAgua portable water testing kit supplied by the Robens Centre (see Organizations on p. 156).

- Following incubation and using oblique lighting, examine the membrane for yellow lactose fermenting colonies, 1–3 mm in diameter (see colour Plate 21). Count the number of colonies. Ignore any pink colonies and very small colonies (less than 1 mm in diameter). When the number of colonies are too numerous to count, report such a confluent growth as 'Too numerous to count' (indicative of gross contamination).
- Calculate the presumptive *E. coli* count/100 ml as follows:
  - 100 ml water sample, multiply number of colonies by 1.
  - 50 ml water sample, multiply number of colonies by 2.
  - 10 ml water sample, multiply number of colonies by 10.

*Note:* Whenever possible use a standardized form to report the water analysis and interpretation of the *E. coli* count (see following text).

#### Interpretation of results

A distinction needs to be drawn between samples from chlorinated and unchlorinated water supplies.

#### Chlorinated samples

- At least 90% of all samples taken over a 12 month period should have a zero *E. coli* count per 100 ml.



- The *E. coli* count should never exceed 5 per 100 ml.

When analyses reveal that these guidelines are not being met, the results should be reported immediately to the treatment plant superintendent who should investigate and rectify the cause of the treatment failure.

*Unchlorinated samples*

Most untreated water supplies contain faecal bacteria but in the case of protected ground water, e.g. springs, sealed wells, and tubewells, it should be possible to achieve very low levels of contamination. The following guidelines are therefore suggested:

Mean count* 44°C, 100 ml <i>E. coli</i> count	Category	Comments
0	A	<b>Excellent</b>
1–10	B	<b>Acceptable:</b> But make regular sanitary checks.
10–50	C	<b>Unacceptable:</b> Look for and correct structural faults and poor maintenance of pump and plinth. Then disinfect equipment and source.
More than 50	D	<b>Grossly polluted:</b> Look for alternative source, or carry out necessary repairs, and disinfect well.

\*Guidelines can only be applied when *routine* survey data are available, e.g. 5–10 consecutive weekly samples.



Plate 7.30 DelAgua portable water testing kit. Courtesy of Robens Centre for Public and Environmental Health.

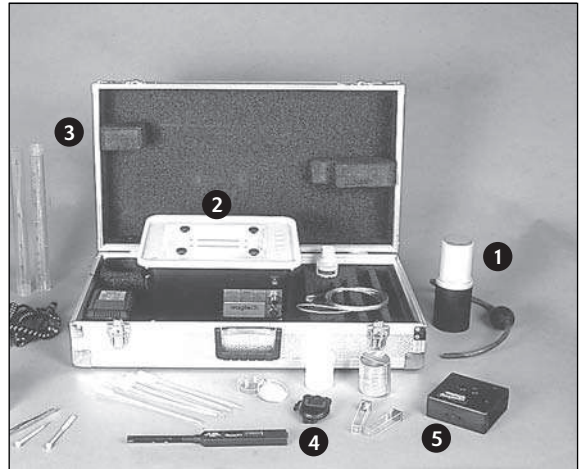

Plate 7.31 Wagtech portable water testing kit (*Potakit 1*). Components: 1 The bacteriological filtration unit

- 2 The Potakit incubator
- 3 Turbidity tube
- 4 Pocket conductivity meter
- 5 Wagtech 225 Comparator kit

Courtesy of Wagtech.

**Important:** A single laboratory examination of any water, whether raw or treated, and however favourable the result, does not justify the conclusion that all is well and that a water supply is suitable for drinking. Contamination is often intermittent and may not be revealed by the examination of a single sample or when samples are tested at lengthy intervals or not during both dry and wet seasons. The value of water analysis is dependent upon it being performed frequently at regular intervals, using tests which can be carried out reliably in the field.

*Note:* To contribute to health care, water supply surveillance must be linked to improvement strategies.

**Multiple tube/MPN technique (see also pp. 149–150)**

*Required*

Bottles of sterile MacConkey broth (purple).

Depending on the type of water sample (treated or untreated), the following are required:

	Number of bottles	ml of broth	Strength of broth*
<i>Treated water samples</i>	1	50	Double
	5	10	Double
<i>Untreated water samples</i>	1	50	Double
	5	10	Double
	5	5	Single

\*Double strength broth refers to broth made up using twice



the normal amount of broth powder. Single strength broth contains the normal amount of broth powder as instructed by the manufacturer.

*Note:* Each bottle of broth must contain an inverted Durham tube for the collection of gas. This is added before the broth is sterilized. Make sure the inverted tube is full of broth and there is no air bubble inside it. If an air bubble is trapped in the tube, invert the bottle of medium to allow the bubble to rise out of the tube.

**Method**

- 1 Label each bottle with the sample code number.
- 2 Mix *thoroughly* the sample of water by inverting the bottle several times.
- 3 Remove the bottle cap and cover, flame the mouth of the bottle, and inoculate the bottles of sterile broth as follows:
  - Add 50 ml of water to the bottle containing 50 ml of broth. This is most easily done by pouring direct into the bottle of broth up to a 100 ml graduation mark scratched previously on the bottle.
  - Using a sterile pipette, add 10 ml of water to each of the five bottles containing 10 ml of broth.
 

*Caution:* Do not mouth pipette the water sample. Use a pipette filler.
  - If required (for untreated samples), pipette 1 ml of water into each of five bottles containing 5 ml of broth.

*Note:* the total volume of water inoculated is 100 ml for treated samples, and 105 ml for untreated poor quality samples.

- 4 Incubate the inoculated broths in a water bath or incubator at 44 °C for 24 hours with the bottles loosely capped.
- 5 After incubation, examine and count each bottle which has produced both acid and gas.

*Note:* Acid production will be shown by a change in colour of the MacConkey broth from purple to yellow, and gas production by the collection of a bubble in the Durham tube.

- 6 Refer to the probability tables shown below to determine the most probable number (MPN) of faecal coliform bacteria in the 100 ml or 105 ml water sample.

**PROBABILITY TABLES FOR ESTIMATING THE MPN OF FAECAL COLIFORM BACTERIA**

**For Treated Water Samples**

<i>Volume of sample in each bottle:</i>	50 ml	10 ml	
<i>Number of bottles used:</i>	1	5	
	0	0	<b>MPN/100ml</b>
	0	1	0
	0	2	1
	0	3	2
	0	4	4
<b>Number of tubes giving positive reaction</b>	0	4	5
	0	5	7
	1	0	2
	1	1	3
	1	2	6
	1	3	9
	1	4	16
	1	5	18+

**For Untreated Water Samples**

<i>Volume of sample in each bottle:</i>	50 ml	10 ml	1 ml	
<i>Number of bottles used:</i>	1	5	5	
	0	0	0	<b>MPN/100 ml</b>
	0	0	1	0
	0	0	2	1
	0	1	0	2
	0	1	1	1
	0	1	2	2
	0	2	0	3
	0	2	1	2
	0	2	2	3
	0	3	0	4
	0	3	1	3
	0	4	0	5
	1	0	0	5
	1	0	1	1
	1	0	2	3
	1	0	3	4
	1	1	0	6
	1	1	1	3
	1	1	1	5
	1	1	2	7
<b>Number of tubes giving positive reaction</b>	1	1	3	9
	1	2	0	5
	1	2	1	7
	1	2	2	10
	1	2	3	12

1	3	0	8
1	3	1	11
1	3	2	14
1	3	3	18
1	3	4	20
1	4	0	13
1	4	1	17
1	4	2	20
1	4	3	30
1	4	4	35
1	4	5	40
1	5	0	25
1	5	1	35
1	5	2	50
1	5	3	90
1	5	4	160
1	5	5	180+

*Note:* The most probable numbers from 0 to 20 are correct to the nearest unit; above 20 are correct to the nearest 5.

*Interpretation of results:* This is given at the end of the membrane filtration technique (see previous text).

### Testing for free residual chlorine

The presence of free residual chlorine in drinking water is used as a measure of the effectiveness of chlorine as a disinfecting agent. To ensure complete



Plate 7.32 Lovibond comparator and DPD tablets for chlorine testing. Courtesy of The Tintometer Ltd.

disinfection, chlorine needs to be added to the water to leave a slight excess. The amount of free residual chlorine in the water should normally be greater than 0.2 mg/l and less than 1 mg/l. The amount will depend on the distance from source to distribution and on the ambient temperature and pH of the water. The presence of free residual chlorine should be checked in all parts of the system.

The DPD (N,N-diethyl-1, 4-phenylenediamine) colorimetric technique is recommended for detecting residual chlorine in water supplies. It can be simply and economically performed in the field using DPD tablets and a visual comparator with standard discs.

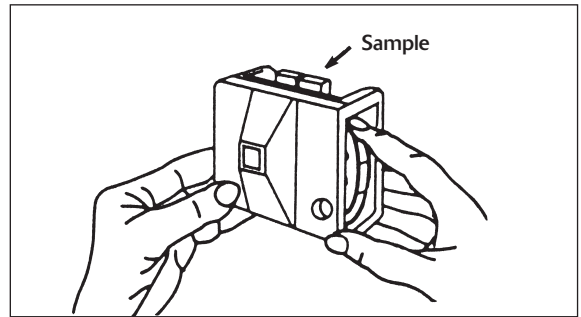

Fig 7.25 Reading the free residual chlorine concentration using a Lovibond comparator.

### Principle

Free chlorine reacts with DPD to form a red-violet compound. By comparing the colour against a set of reference standards, the amount of free residual chlorine can be determined.

### DPD 1 Lovibond comparator method for estimating free chlorine

- 1 Add one No. 1 DPD tablet to a few ml of the water sample in the 10 ml comparator tube (cell) provided.

*Note:* DPD No. 1, code 511060 for 100 tablets, visual Lovibond 2000 comparator, and disc of standards are available from the Tintometer Company (see Appendix 11). Similar products are also available from Palintest Company (see Appendix 11) and other manufacturers.

- 2 Using a clean rod, crush the tablet in the water or wait 1–2 minutes for the tablet to dissolve naturally.
- 3 Fill the tube to the 10 ml mark with the water sample, and mix. Place the tube in the right hand compartment of the comparator.
- 4 Fill another comparator tube to the 10 ml mark with the water sample, and place this in the left hand compartment of the comparator.

- Using standard Lovibond disc 3/40A, code 234010 (range 0.1–1.0 mg/l) or 3/40B, code 234020 (range 0.2–4.0 mg/l), match the colour of the reacted water sample against the standards (see Fig. 7.25).
- Record the amount of free residual chlorine in mg/l in the sample.

*Note:* When a strong colour is obtained which subsequently fades or disappears altogether when the solution is made up to full volume, this indicates that a high concentration of chlorine is present. The water sample should be diluted and re-tested.

### Measuring turbidity

A calibrated turbidity tube method is a simple inexpensive way of measuring the turbidity of water samples in the field. Alternatively, a turbidity meter can be used but this is expensive. Groundwater should always be less than 5 Turbidity Units (TU). This is needed for effective disinfection. Ideally, drinking water should have a turbidity value of less than 1 TU. At 5TU, turbidity can be seen by eye.

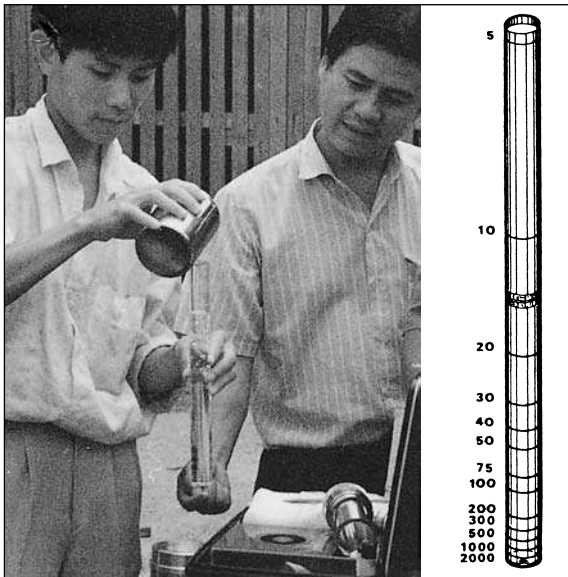

Plate 7.33 Measuring turbidity of water using a calibrated tube. *Reproduced from World Health Magazine, July–August, 1992.*

*Right:* Calibrated turbidity tube.

### Availability of turbidity tube

A 716 mm (28 inch) break-resistant plastic turbidity tube (double length, two part tube), calibrated from 5–25 TU is available from Palintest Ltd, code number PT 513 (see Appendix 11). A similar tube is also available from the Tintometer Ltd, code 384960 (see Appendix 11).

### Method

- Join the two tubes by pushing the upper tube into the lower one. Note the black cross at the bottom of the tube.
- Looking down through the tube and holding it over a white surface, slowly pour the water sample into the tube until the black cross is just no longer visible (avoid introducing air bubbles)\*. When the cross is no longer clearly visible, this is the endpoint. Read off the turbidity units on the side of the tube, i.e. the graduation which corresponds to the water level.

\*If bubbles form when pouring in the water, wait until they have risen to the top of water column before taking the reading.

*Note:* When a chlorinated water supply contains more than 0.2 mg/l free chlorine and gives a turbidity reading of less than 5 TU, it is unlikely to contain faecal coliforms. There is no need to perform bacteriological analysis (i.e. *E. coli* count).

### FURTHER INFORMATION

#### PAPERS

**Bartram J.** New water forum will repeat old message. *Bulletin of World Health Organization*, 2003, 81(3), p. 158.

**MacDonald AM et al.** Providing the world with clean water. *British Medical Journal*, 2003, Vol. 327, 20–27 December, pp. 1416–1418.

**Roberts L et al.** Keeping clean water in a Malawi refugee camp, a randomised intervention trial. *Bulletin of World Health Organization*, 2001, 79(4), pp. 280–286.

**Franceys R.** Water for the urban poor. *Footsteps* (water issue), 2002, No. 51, June.

#### BOOKS

**Sutton S.** *Low cost water source improvements*, TALC, 2004.

**WHO.** *The sanitation challenge. Turning commitment into reality*. World Health Organization, 2004. ISBN 924 159162 5.

**Sutton S et al.** *Encouraging change – sustainable steps, water supply, sanitation and hygiene*. TALC, DFID, 2002.

**Howard G.** *Water quality surveillance – A practical guide*. WEDC, 2002. ISBN: 1 84380 0039.

**Rottier E et al.** *Controlling and preventing disease – The role of water and sanitation interventions*. WEDC, 2003. ISBN 0 90605590 3.

**Skinner B.** *Small scale water supply – A review of technologies*. ITDG Publishing, 2003. ISBN 1 85339 5404.

**House S. et al.** *Emergency water sources – Guidelines for selection and treatment*, WEDC, 3rd edition, 2004. ISBN 1 84380 0691.

**WHO.** *Water for life – Making it happen*. World Health Organization, Geneva, 2005.

**Gould J.** *Rainwater catchment systems for domestic supply.* ITDG Publishing, 1999. ISBN 1 853394 564.

**Adams J.** *Managing water supply and sanitation in emergencies,* Oxfam, 1999. ISBN 0 85598 3787.

**Wisner B. et al.** *Environmental health in emergencies and disasters: A practical guide.* World Health Organization, Geneva, 2002. ISBN 924 1545410.

**Taylor K. et al.** *Urban sanitation – A guide to strategic planning.* ITDG Publishing, 2003. ISBN 1 85339 5587.

#### WEBSITES

- **WHO Water, Sanitation and Health website:** [www.who.int/water\\_sanitation\\_health](http://www.who.int/water_sanitation_health)
- **WHO/UNICEF Joint Monitoring Programme for water supply and sanitation website:** [www.wssinfo.org](http://www.wssinfo.org)
- **UN Water for Life International Decade 2005–2015 website:** [www.un.org/waterforlifedecade](http://www.un.org/waterforlifedecade)

#### World Health Organization: Guidelines for drinking water quality

- *Guidelines for drinking water quality: Volume 1 Recommendations,* 3rd edition. WHO Geneva. 2004. ISBN 9 2415 4638 7.
- *Guidelines for drinking water quality: Volume 11 Health and other supporting criteria,* 2nd edition. WHO Geneva 1996. ISBN 9 2415 4480 5.
- *Guidelines for drinking water quality: Volume 111 Surveillance and control of community supplies,* 2nd edition. WHO Geneva 1998. ISBN 9241 545 038.

---

#### ORGANIZATIONS PROVIDING INFORMATION ON WATER SUPPLY AND SANITATION

##### Intermediate Technology Publications (ITDG)

The Schumacher Centre for Technology & Development  
Bourton Hall  
Bourton-on-Dunsmore  
Rugby  
CV23 9QZ, UK  
Phone +44 (0) 1926 634501  
Fax +44 (0) 1926 634502  
E-mail: [marketing@itpubs.org.uk](mailto:marketing@itpubs.org.uk)  
Website: [www.itdgpublishing.org.uk](http://www.itdgpublishing.org.uk)

Publisher of *Waterlines*, an excellent quarterly journal providing information on appropriate technologies for water supply and sanitation in developing countries. Also publishes and distributes a wide range of books covering water, sanitation, and hygiene.

##### Water Engineering and Development Centre (WEDC)

Loughborough University  
Leicestershire, LE11 3TU, UK.  
Phone +44 (0) 1509 222885  
Fax +44 (0) 1509 211079  
E-mail: [WEDC@lboro.ac.uk](mailto:WEDC@lboro.ac.uk)  
Website [www.lboro.ac.uk/departments/cv/wedc/](http://www.lboro.ac.uk/departments/cv/wedc/)

WEDC provides information and runs courses (including postgraduate *Distance Learning Programme*) on water and environmental health, low cost sanitation technologies,

planning provision and management of water for low income countries.

##### Robens Centre for Public and Environmental Health

University of Surrey  
Guildford, GU2 7XH, UK.  
Phone +44 (0) 1483 689209  
Fax +44 (0) 1483 689971  
E-mail [delagua@surrey.ac.uk](mailto:delagua@surrey.ac.uk)  
Website [www.rcteh.com](http://www.rcteh.com)

Supplier of Oxfam's DelAgua portable water-testing kit. Also provides advice on water quality issues, including designing and monitoring programmes for drinking water and pollution control, groundwater quality management and protection, laboratory analysis, and where to access equipment supplies.

##### WaterAid

Prince Consort House  
27–29 Albert Embankment  
London, SE1 7UB, UK.  
Phone +44 (0) 20 7793 4500  
Fax +44 (0) 20 7793 4545  
E-mail: [information@wateraid.org.uk](mailto:information@wateraid.org.uk)  
Website [www.wateraid.org.uk](http://www.wateraid.org.uk)

WaterAid aims to work through partner organizations to help people in developing countries achieve sustainable improvements in their quality of life by improved domestic water supply, sanitation and associated hygiene practices.

##### International Research Development Centre (IRDC)

PO Box 8500  
Ottawa, ONK1G 3HP, Canada  
Phone +1 613 236 6163  
Fax +1 613 238 7230  
Website [www.idrc.ca](http://www.idrc.ca)

Provides information on analytical, toxicological, microbiological and biological aspects of monitoring and design programmes for drinking and natural waters. Also operates GARNET (Global Applied Research Network in Water Supply and Sanitation).

##### IRC International Water and Sanitation Centre

PO Box 2869  
2601 CW Delft  
The Netherlands  
Phone +31 15 219 2939  
Fax +31 15 219 0955  
E-mail: [general@irc.nl](mailto:general@irc.nl) Website [www.irc.nl](http://www.irc.nl)

Working with partners in developing countries, IRC helps developing countries to get the best water and sanitation services they can afford with an emphasis on community management, gender awareness, hygiene promotion, operation and maintenance, monitoring and evaluation. Also publishes and distributes books on water and sanitation, related issues and information on training programmes.

##### RedR – Engineers for Disaster Relief

1 Gt George Street  
London  
SW1P 3AA, UK  
Phone +44 (0) 207 233 3116  
Fax +44 (0) 207 233 3590  
Website [www.redr.org](http://www.redr.org)

RedR – Engineers for Disaster Relief – relieves suffering in disasters by selecting, training and providing competent and effective personnel to humanitarian relief agencies world-wide. Provides personnel to work on water supply and sanitation in emergencies. Produces *Engineering in Emergencies* (published by IT Publications). Runs various training courses on subject.

## 7.18 Summary of the clinical and laboratory features of microorganisms

This subunit summarizes the pathogenicity and laboratory features of the most important pathogens found in tropical and developing countries. References and sources of further information can be found at the end of each subunit.

### BACTERIAL PATHOGENS

#### 7.18.1 *Staphylococcus aureus*

##### Pathogenicity

*S. aureus* causes boils, styes, pustules, impetigo, infections of wounds (cross-infections), ulcers and burns, osteomyelitis, mastitis, septicaemia, meningitis, pneumonia and pleural empyema. Also, toxic food-poisoning (rapid onset, no fever), toxic shock syndrome and toxic skin exfoliation. *S. aureus* is carried in the nose and on the skin of many healthy people. It is easily spread in hospitals, particularly on surgical wards.<sup>1</sup>

##### Extracellular enzymes and toxins produced by strains of *S. aureus* that contribute to its invasiveness and pathogenicity

- *Coagulase*: Clots plasma, interferes with phagocytosis, facilitates spread in the tissues.
- *Haemolysins*: Lyse red cells.
- *Leukocidin*: Kills leucocytes.
- *Fibrinolysin*: Digests fibrin.
- *Lipase*: Breaks down fat.
- *Hyaluronidase*: Facilitates spread in tissues by destroying hyaluronic acid (component of connective tissue).
- *Protein A*: Antiphagocytic (prevents complement activation).

- *Enterotoxins* (heat stable): Cause food-poisoning (particularly vomiting).
- *Toxic shock syndrome toxin-1*: Shock, rash, desquamation of skin.
- *Epidermolytic toxins A and B*: Generalized peeling of the skin.
- *Chemotaxis inhibitory protein*: Inhibits migration and activation of neutrophils.

##### LABORATORY FEATURES

*Specimens*: Pus and swabs from infected sites, sputum, cerebrospinal fluid, blood for culture. Faeces, vomit and the remains of food when food-poisoning is suspected.

##### Morphology

Staphylococci are Gram positive cocci of uniform size, occurring characteristically in groups but also singly and in pairs (see colour plate 24). They are non-motile and non capsulate.

##### Culture

Staphylococci grow well aerobically and in a carbon dioxide enriched atmosphere. Most strains also grow anaerobically, but less well. Temperature range for growth is 10–42 °C, with an optimum of 35–37 °C.

##### *Blood agar, chocolate (heated blood) agar*:

*S. aureus* produces yellow to cream or occasionally white 1–2 mm in diameter colonies after overnight incubation (see colour Plates 22 and 23). Pigment is less pronounced in young colonies. Some strains are *beta*-haemolytic when grown aerobically. Colonies are slightly raised and easily emulsified.

##### *MacConkey agar*:

Smaller (0.1–0.5 mm) colonies are produced after overnight incubation at 35–37 °C. Most strains are lactose fermenting.

##### *Mannitol salt agar*:

A useful selective medium for recovering *S. aureus* from faecal specimens when investigating staphylococcal food-poisoning. It can also be used to screen for nasal carriers. *S. aureus* ferments mannitol and is able to grow on agar containing 70–100 g/l sodium chloride. Mannitol salt agar containing 75 g/l sodium chloride (plus 4 mg/l methicillin) is recommended, particularly for isolating MRSA strains (see later text). *Note*: Preparation of each culture medium is described in Appendix 1.

### Biochemical tests

*S. aureus* is:

- Coagulase positive (see subunit 7.5.4).
- DNA-ase positive (see subunit 7.5.5)
- Catalase positive (see subunit 7.5.2)

Note: Other tests occasionally required to differentiate *S. aureus* from other species of *Staphylococcus* are summarized at the end of this subunit.

### Commercially produced test kits to identify *S. aureus*

Several latex agglutination test kits are available to identify *S. aureus* based on the detection of clumping factor and, or, protein A (latex particles are sensitized with fibrinogen and immunoglobulin G). The manufacturer's literature must be read carefully, particularly regarding specificity and sensitivity and whether the test detects MRSA (methicillin-resistant *S. aureus*) strains.

#### Pastorex Staph Plus test

This latex agglutination test kit is available from Bio-Rad Laboratories (see Appendix 11). It detects all strains of *S. aureus*, including up to 95% MRSA strains (reagent contains antibodies to the capsular polysaccharides found in MRSA as well as fibrinogen and protein A). A test kit of 50 tests (code 56356) has a shelf-life of 12–18 months when stored at 2–8°C.

#### Dryspot Staphylect Plus

This latex agglutination test, available from Oxoid (see Appendix 11) uses reagent that has been dried on a reaction card. It detects up to 97% of *S. aureus* strains, including most MRSA. Colonies of *S. aureus* are emulsified in saline and mixed with the dry reagent. Agglutination of the blue latex particles indicates a positive test. Test cards can be stored at room temperature (up 25°C). Each pack contains 120 tests (code DR0100M).

#### Commercially available test kits to confirm MRSA

Test kits have become available to detect penicillin binding protein 2 (PBP2) for the rapid detection of MRSA. PBP2 is a product of the Mec A gene which confers methicillin resistance. An example of a PBP2 latex agglutination test is *Mastalex MRSA*, produced by Mast Group (see Appendix 11). The test has been shown to be 97% specific and sensitive for the detection of MRSA.<sup>3</sup> PBP2-based tests are expensive.

### Antimicrobial susceptibility

Antibiotics with activity against *S. aureus* include:

Penicillins*	Vancomycin
Macrolides	Cephalosporins
Fusidic acid	

\*Most strains of *S. aureus* (particularly hospital strains) are resistant to penicillin due to the production of plasmid-coded beta-lactamase (see also subunit 7.16).

**MRSA (methicillin resistant *S. aureus*):** These strains are resistant to methicillin and related penicillins and are particularly difficult to treat because

they are also resistant to most other common antibiotics. Vancomycin is often needed to treat MRSA infections. Cultures are usually a mixture of sensitive and resistant organisms. MRSA strains cause hospital-acquired infections, particularly wound infections and septicaemia. Improved control measures and surveillance are required to combat increases in the isolation rates of multi-drug resistant MRSA in hospital environments.<sup>1,2</sup>

### Other pathogenic *Staphylococcus* species

- *Staphylococcus saprophyticus*: Causes urinary tract infections in sexually active women.
- *Staphylococcus epidermidis*: May cause endocarditis and bacteraemia following infection of cannulae, indwelling catheters, shunts or other appliances positioned in the body. Infections are difficult to treat due to the resistance of *S. epidermidis* to many antimicrobials.

Microscopically, *S. saprophyticus* and *S. epidermidis* resemble *S. aureus*.

Culturally the colonies of *S. epidermidis* are white and usually non-haemolytic. The colonies of *S. saprophyticus* may be white or yellow. They are non-haemolytic. Growth may not occur on MacConkey agar. *S. saprophyticus* and *S. epidermidis* are coagulase negative.

### Biochemical reactions that differentiate *S. epidermidis* and *S. saprophyticus* from *S. aureus*

Test	<i>S. aureus</i>	<i>S. epidermidis</i>	<i>S. saprophyticus</i>
Coagulase	+	–	–
DNA-ase	+	+ Weak	–
Mannitol*	+	–	+
Trehalose*	+	–	+
Sucrose*	+	+	+
Novobiocin (5 µg disc)	S	S	R

Notes: \*Fermentation tests: + = Sugar fermented with acid production (sugar tablet tests are available from Rosco Diagnostics, see Appendix 11) S = Susceptible, R = Resistant

### REFERENCES

- 1 Navaneeth BV *et al.* Methicillin-resistant *S. aureus* in a tertiary care hospital (Bangalore). *Tropical Doctor*, July 2002.
- 2 World Health Organization. *Prevention of hospital-acquired infections*, 2nd edition, 2002.
- 3 Bowers KM *et al.* Screening for methicillin resistance in *S. aureus* and coagulase negative staphylococci: an

evaluation of three selective media and *Mastalex* – MRSA latex agglutination. *British Journal Biomedical Science*, 60, pp. 71–74, 2003.

## 7.18.2 *Streptococcus pyogenes*

### Classification of streptococci and enterococci

Subunits 7.18.2–7.18.5 describe the main species of pathogenic streptococci and enterococci. These organisms are broadly classified by their haemolytic activity on blood agar (*alpha*, *beta*, non-haemolytic) and in the case of *beta*-haemolytic streptococci, and enterococci, by Lancefield group antigens in their cell wall (envelope). Streptococci, formerly classified as Group D streptococci, are now included in the genus *Enterococcus* e.g. *S. faecalis* has been reclassified *E. faecalis*.

### Pathogenicity

*S. pyogenes* (Lancefield Group A) causes sore throat (tonsillitis, pharyngitis), peritonsillar abscess (quinsy), scarlet fever, otitis media, cellulitis, impetigo, necrotizing fasciitis, erysipelas, puerperal sepsis, septicaemia, and occasionally toxic shock syndrome. Also immune-mediated post-streptococcal rheumatic fever (following throat infections) and glomerulonephritis (after skin or throat infections). In developing countries, rheumatic heart disease is an important cause of death among school-age children.

*Note:* *S. pyogenes* can be found as a commensal in the upper respiratory tract, particularly of children.

### Extracellular enzymes and toxins produced by strains of *S. pyogenes* that contribute to its invasiveness and pathogenicity

- *Streptolysins* (toxins that haemolyze red cells):
  - Streptolysin S that is active aerobically (*beta*-haemolysis on blood agar). It is non-antigenic.
  - Streptolysin O that haemolyzes red cells under anaerobic conditions, e.g. sub-surface agar stabs. It is antigenic, stimulating the production of antistreptolysin O antibody (ASO), see later text.
- *Streptokinase*, a protease that lyses fibrin.
- *Hyaluronidase*: Facilitates spread in the tissues by destroying hyaluronic acid. Streptococcal hyaluronidase is antigenic (antibody formed after infection).
- *Leukocidin*: Destroys leucocytes.
- *Lipoteichoic acid*: Facilitates adherence to pharyngeal epithelial cells.
- *M-proteins* (antigens): Anti-phagocytic virulence factors (different for different strains). Antibodies to M antigens

are protective. Selected M serotypes appear to be associated with rheumatic fever, acute glomerulonephritis, and severe *S. pyogenes* infections.

- *NADase* (nicotinamide adenine dinucleotidase): Kills leukocytes. Antibody formed after infection.
- *DNA-ases* (deoxyribonuclease) A, B, C, D that break down DNA and stimulate an antibody response, particularly against DNA-ase B. Anti-DNA-ase B tests are available.
- *Erythrogenic toxin*: Responsible for the rash seen in scarlet fever and is also associated with streptococcal toxic shock syndrome. It is produced as a result of a lysogenic phage present in the streptococci.

### LABORATORY FEATURES

*Specimens:* Include a throat swab (avoiding saliva contamination) or swabs of pus and serous fluid depending on the site of infection, and blood for culture. Culture media should be inoculated as soon as possible or a swab placed in a tube of silica gel (see subunit 7.7) Testing for ASO antibody in serum is helpful in diagnosing rheumatic fever.

### Morphology

Streptococci are Gram positive cocci, occurring characteristically in short chains, but also in pairs and singly (see colour Plate 25). Long chains are formed in fluid cultures. The organisms are non-motile. Some strains are capsulated.

### Culture

**Blood agar:** *S. pyogenes* produces *beta*-haemolytic colonies, i.e. the colonies are surrounded by a zone of complete haemolysis with decolorization of the haemoglobin as shown in colour Plates 26 and 27. Colonies are usually small (0.5–1 mm), colourless, dry, shiny or mucoid. Haemolysis is more marked under anaerobic conditions as seen in colonies growing below the agar surface (following stabs made in the culture medium, see subunit 7.7).

### Choice of blood

To isolate *beta*-haemolytic streptococci, use sheep blood (1st choice), horse, rabbit or goat blood to prepare blood agar plates. Do not use human blood because this may contain unwanted substances such as citrate (e.g. donor blood), antibiotics, or antibodies such as ASO or anti-M protein that could interfere with the growth or haemolytic activity of *S. pyogenes*.

*Note:* Other *beta*-haemolytic streptococci (belonging to other Lancefield groups) also

produce colonies similar to *S. pyogenes*. *Beta*-haemolysis may also be seen with some strains of *S. aureus*, *Haemophilus* (particularly from throat swabs), *Corynebacterium* and *Moraxella*. It is therefore important to examine a Gram stained smear of the culture.

A catalase test can be used to differentiate streptococci (negative) from staphylococci (positive). When grown on Columbia blood agar, some *alpha*-haemolytic streptococci may show *beta*-haemolysis.

#### Sensitivity to bacitracin

Adding a bacitracin disc (0.04 or 0.05 IU, not higher), to a plate of blood agar or preferably a selective medium, is a useful method of screening for *S. pyogenes*. Most strains are sensitive to bacitracin (see colour Plate 26), but it is not possible to rely completely on sensitivity to bacitracin to identify *S. pyogenes*. Other non-Group A *beta*-haemolytic streptococci (e.g. Groups B, C and G) may occasionally also show sensitivity to bacitracin. Serological grouping is required. Performing a PYR test (see later text) is a further way of establishing a presumptive diagnosis of *S. pyogenes* when the reagents for serogrouping are not available.

*Note:* *S. pyogenes* is always sensitive to benzylpenicillin and therefore placing a 1 µg disc of the antibiotic on a primary culture plate (well area) can also help to presumptively identify *S. pyogenes*.

#### Crystal violet (1 in 50 000) blood agar:

This is a useful inexpensive selective medium for isolating *S. pyogenes* from patients with impetigo where *S. aureus* may be present with *S. pyogenes*. Crystal violet will inhibit the growth of *S. aureus*. Alternatively, use a 30 µg neomycin disc on the heavy part of the inoculum.

**MacConkey agar:** *S. pyogenes* does not grow on this medium.

*Note:* Preparation of each culture medium is described in Appendix 1.

### Biochemical tests

*S. pyogenes* is:

- Catalase negative (staphylococci are positive)
- PYR positive\*

**\*PYR (pyrrolidonyl) test:** This detects pyrrolidonyl peptidase enzyme activity. Besides *S. pyogenes*, *Enterococcus* species and occasionally streptococci belonging to groups C and G are also PYR positive. The test can be rapidly and simply performed using PYR impregnated strips (available from several sup-

pliers including Mast Group and Oxoid), or less expensively by using a Rosco pyrrolidonyl tablet test (code 47011). See Appendix 11 for details of manufacturers.

### Lancefield grouping

*S. pyogenes* belongs to Lancefield Group A. Pure growth *beta*-haemolytic colonies (confirmed catalase negative, Gram positive streptococci) are grouped using specific Group A antiserum to identify the A antigen extracted from the cell wall of the bacteria. Most laboratories use a rapid agglutination test (coagglutination or latex) to Lancefield group *beta*-haemolytic streptococci. Tests which use an enzyme reagent to extract the antigen appear to be more sensitive and easier to read than those which use acid extraction. The manufacturer's instructions must be followed exactly, particularly as regards the density of the bacterial suspension and controls to include.

*Positive group A test:* Indicates that the organism is *S. pyogenes* (particularly when bacitracin sensitive and PYR positive) but possession of A antigen is not species specific. Very occasionally other *beta* haemolytic streptococci group as A.

### Availability of streptococcal grouping tests

Several manufacturers provide only *complete* streptococcal grouping kits, i.e. containing reagents to identify groups A, B, C, D, F, G and an extraction reagent (s). Such complete kits are very expensive. While a minority of *beta*-haemolytic streptococci may occasionally cause infections of the respiratory tract or skin, they do not cause post-streptococcal complications (e.g. rheumatic fever, glomerulonephritis) like Group A *Streptococcus*. The following are among those manufacturers that supply Group A reagent and antigen extraction reagent separately (approximately 12 month shelf-life), and use an enzyme extraction method:

- *Pastorex Strop A:* group reagent, code 61726 (50 test kit) and extraction enzyme reagent code 61729 for 2 × 10 ml, are available from Bio-Rad Laboratories.
- Oxoid: latex grouping A reagent, code DR0586G, for 50 tests, and enzyme extraction reagent (dried), code DR0593G for 2 × 12 ml.
- bioMérieux: *Slidex Strepto A* grouping reagent, code 58815 for 40 tests, and enzyme extraction reagent (liquid) code 58814 for 2 × 10 ml.

*Note:* Details of manufacturers can be found in Appendix 11.

*Other techniques for grouping and serotyping beta-haemolytic streptococci*

For details of the capillary precipitin test and other streptococcal grouping techniques, and the serotyping of Lancefield Group A *streptococcus* (for epidemiological purposes), readers are referred to



the WHO publication *Laboratory diagnosis of Group A streptococcal infections*.<sup>1</sup>

### Direct detection of antigen A from throat swab extracts

Several tests have been developed to detect antigen A directly extracted from throat swabs without the need to culture the specimen, thus providing an early presumptive diagnosis of streptococcal sore throat. Most of the rapid direct tests are immunochromatographic (IC) enzyme immunoassays (with built-in control) or latex agglutination techniques. Suppliers of direct antigen A detection kits include Acorn Laboratories, Biomerica, Savyon Diagnostics, Unipath, and Trinity Biotech (see Appendix 11). Most tests have a shelf-life of about 1 year when stored at 2–8 °C.

Direct antigen A detection tests are highly specific but sensitivity varies between manufacturers (consult their literature). Tests are also influenced by the quality of the specimen. Culturing is required when infection with *S. pyogenes* is suspected and a direct antigen test is negative.

### Measurement of ASO antibody in serum

ASO (anti-streptolysin O) antibody is formed in response to infection with *S. pyogenes* and other streptococci that produce streptolysin O (some Group C and G strains). Following infection, most patients show a high titre of ASO antibody (in excess of 200 IU/ml). Measurement of ASO antibody titre is important in the investigation of post-streptococcal diseases, particularly rheumatic fever which usually develops 2–3 weeks or more after streptococcal sore throat when it is often not possible to isolate *S. pyogenes* in culture.

In rheumatic fever there is a rise in ASO antibody titre in 80–85% of patients. As shown in Fig. 7.26, the rise begins early in the course of the disease with highest levels being reached soon after onset of the disease. In the second week, the level begins to fall. Rheumatic fever is a serious post-streptococcal complication because it can lead in later life to chronic valvular disease of the heart.

**Note:** When post-streptococcal glomerulonephritis is suspected, estimation of the DNase B antibody level is of greater value than measuring the ASO titre (see later text).

#### ASO antibody tests

Rapid, simple to perform latex agglutination and other carrier particle tests are widely available to screen for and measure semi-quantitatively raised levels of ASO antibody in serum. Most tests have a

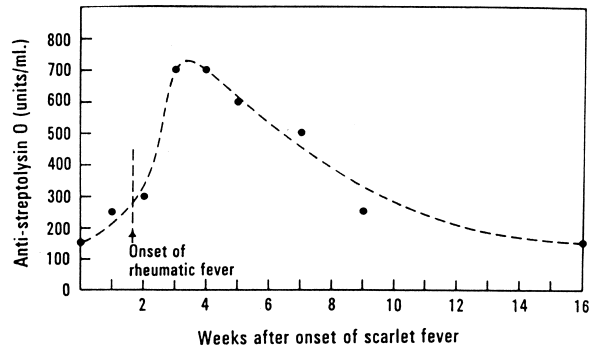

Fig 7.26 Variations in anti-streptolysin O (ASO) titre in a patient with rheumatic fever following scarlet fever.

detection limit of 200 IU/ml, i.e. antibody levels below 200 IU/ml will give a negative test result. The test should be repeated at weekly intervals to detect rising ASO antibody levels, and to determine the effectiveness of treatment. Lower titres of ASO antibody will be found in patients who have been treated with antibiotics.

Non-streptococcal conditions that occasionally cause positive reactions (usually less than 500 IU/ml) in ASO antibody tests include rheumatoid arthritis, tuberculosis, pneumococcal pneumonia, gonorrhoea, and hepatitis. A false test result can occur if the patient's serum is markedly lipaemic or bacterially contaminated. Haemolyzed specimens are not suitable for ASO antibody testing.

#### Availability of latex ASO antibody tests

Most suppliers of microbiological diagnostic products offer rapid ASO antibody tests, but prices vary considerably between suppliers. Examples of suppliers of ASO latex agglutination tests include Omega Diagnostics, Plasmatec, Tulip Group, and Wiener Laboratories. Details of manufacturers can be found in Appendix 11.

**Note:** Haemolytic assay methods for accurately measuring ASO antibody in human serum and information on the interpretation of test results, are described in the WHO booklet *Laboratory diagnosis of Group A streptococcal infections*.<sup>1</sup>

### Measurement of DNA-ase B antibody

Most increases in DNA-ase B (deoxyribonuclease B) antibody titres occur in response to Group A streptococcal infection. The rise in DNA-ase B antibody usually occurs later than the rise in ASO antibody. Measurement of anti-DNA-ase B is of value when investigating acute glomerulonephritis following a streptococcal skin infection (rather than

a streptococcal sore throat). This is because the ASO antibody titre is not usually raised following streptococcal skin infections whereas there is a rise in titre of anti-DNA-ase B.

Measuring DNA-ase antibody levels in serum is usually carried out in a specialist microbiology laboratory. It is uneconomical for district/regional laboratories to perform DNA-ase tests.

### Antimicrobial susceptibility

*S. pyogenes* strains are susceptible to penicillin. Erythromycin is usually used to treat patients hypersensitive to penicillin but resistance to erythromycin (and also to tetracyclines) is being increasingly reported.

#### REFERENCE

- 1 *Laboratory diagnosis of group A streptococcal infections* 1996, WHO, ISBN 9241544953. Obtainable from WHO Publications, WHO, Geneva 1211, 27-Switzerland.

## 7.18.3 *Streptococcus agalactiae*

### Pathogenicity

*S. agalactiae* (Lancefield Group B) causes septic abortion and puerperal or gynaecological sepsis, and occasionally urinary tract infection. *S. agalactiae* forms part of the normal microbial flora of the female genital tract. Occasionally it causes neonatal septicaemia and meningitis (rare in most developing countries).

**In cattle**, *S. agalactiae* is a common cause of bovine mastitis. Human strains are distinct from animal strains.

### LABORATORY FEATURES

**Specimens:** Include cerebrospinal fluid, ear swab, and blood for culture from neonates. High vaginal swab is required from women with suspected sepsis.

### Morphology

Group B streptococci are Gram positive cocci, occurring characteristically in short chains but also in pairs and singly.

The organisms are non-motile. Most strains are capsulated.

### Culture

**Blood agar:** Most strains of *S. agalactiae* produce grey mucoid colonies about 2 mm in diameter, surrounded by a small zone of *beta*-haemolysis (clear area with decolorization of haemoglobin). About 5% of strains are non-haemolytic. Placing discs of penicillin and gentamicin on the plate can help to identify these strains (penicillin sensitive, gentamicin resistant).

**MacConkey agar:** Most strains grow on this medium.

**Neomycin blood agar:** A useful selective medium for isolating *S. agalactiae* from urogenital specimens.

**Orange pigment:** Produced by *S. agalactiae* when cultured on serum starch agar anaerobically.

*Note:* Preparation of each culture medium is described in Appendix 1.

### Lancefield grouping

*S. agalactiae* belongs to Lancefield Group B. Serological identification of the organism can be made by testing the *beta*-haemolytic colonies from a blood agar culture (confirmed as catalase negative, Gram positive cocci) for B antigen using Group B antiserum reagent. The technique is similar to that described for grouping *Streptococcus* Group A (see previous subunit). Manufacturers that supply Group B reagent and extraction reagent are the same as those listed for Group A reagent in subunit 7.18.2.

*Note:* When reagents for streptococcal grouping are not available, *S. agalactiae* can be identified presumptively by the CAMP test and hippurate hydrolysis test (see following text).

### CAMP (Christie, Atkins, Munch, Peterson) test to identify presumptively *S. agalactiae*

This test requires the use of a *beta*-lysin producing strain of *S. aureus* (NCTC 1803 or ATCC 25923) to detect the CAMP factor, i.e. extracellular diffusible protein produced by *S. agalactiae*. This protein interacts with the staphylococcal *beta*-lysin on sheep (or ox) blood agar producing enhanced haemolysis.

The test is performed by streaking a known *beta*-lytic *Staphylococcus* strain across a 10% blood agar plate and then inoculating the test organism at right angles to it. The test organism must not touch the staphylococcal inoculum. An *Enterococcus* species is also inoculated as a negative control. The test organism is presumed to be *S. agalactiae*, if after

overnight incubation at 35–37°C, there is an arrow-head shaped area of haemolysis where the staphylococcal organism meets the test organism (see Fig. 7.27).

**Bile aesculin stope:** *S. agalactiae* does not hydrolyse aesculin. It is able to grow on bile agar. Group A *Streptococcus pyogenes* gives a variable aesculin hydrolysis reaction and does not grow on bile agar. Group D streptococci hydrolyse aesculin and can grow on bile agar.

#### Hippurate hydrolysis test

*S. agalactiae* hydrolyzes hippurate. The test can be inexpensively and rapidly performed using a saline suspension of the test organism and a Rosco Diagnostica hippurate hydrolysis tablet, code 56711 and ninhydrin 3.5% reagent, code 917-31 (see Appendix 11 for details of manufacturer).

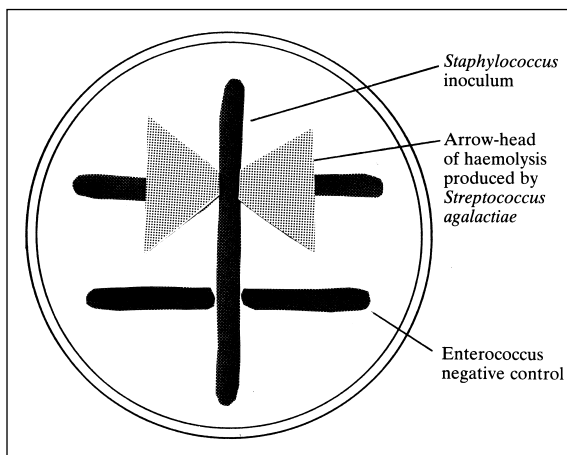

Fig 7.27 CAMP reaction of *Streptococcus agalactiae* (Group B).

#### Direct detection of Group B streptococcal antigen in c.s.f.

When Group B streptococcal meningitis is suspected, a rapid diagnosis can be made by detecting Group B streptococcal antigen directly in c.s.f., serum or urine using a latex or coagglutination slide test. Direct tests are expensive. They are particularly useful if antibiotic treatment has been started and it is not possible to isolate *S. agalactiae* culturally.

**Availability of Group B streptococcal direct antigen tests**  
bioMérieux supply a 30 test kit, *Slidex meningite strepto B*. Other manufacturers include BD Diagnostics and Bio-Rad Laboratories (see Appendix 11 for details of manufacturers).

#### Antimicrobial susceptibility

*S. agalactiae* has the same susceptibility profile as *S. pyogenes*.

## 7.18.4 *Streptococcus pneumoniae*

#### Pathogenicity

*S. pneumoniae* causes lobar pneumonia, bronchitis (often with *H. influenzae*), meningitis, bacteraemia, otitis media, sinusitis and conjunctivitis. Severe infections can occur in the elderly and those already in poor health or immunosuppressed. Risk of infection is increased following splenectomy.

In tropical and developing countries, *S. pneumoniae* is a major pathogen, responsible for acute life-threatening pneumonia and bacteraemia in those co-infected with HIV. It is also a common cause of childhood pneumonia and serious infections in patients with sickle cell disease. Pneumococci form part of the normal microbial flora of the upper respiratory tract.

**Serotypes:** Over 80 capsular serotypes of *S. pneumoniae* have been identified. Less than 15 serotypes are responsible for most infections.

#### LABORATORY FEATURES

**Specimens:** Depending on the site of infection, specimens include sputum, exudate, blood for culture, and cerebrospinal fluid.

#### Morphology

*S. pneumoniae* is a Gram positive elongated (lanceolate) diplococcus. It also forms short chains, particularly following culture. Pneumococci are non-motile and capsulated (non-capsulated following culture). In Gram stained smears from specimens, the capsule can often be detected as an unstained empty area around the diplococcus as shown in colour Plate 28.

#### Culture

**Blood agar:** Following overnight incubation. *S. pneumoniae* forms translucent or mucoid colonies, 1–2 mm in diameter. In young cultures the colonies are raised but later become flattened with raised edges, giving them a ringed appearance ('draughtsmen'). Strains of some serotypes (e.g. serotype 3) produce large mucoid colonies. Pneumococci show *alpha*-haemolysis, i.e. colonies are surrounded by an area of partial haemolysis

with a green-brown discoloration in the medium (reduced haemoglobin), see colour Plate 29.

*Note:* When cultured anaerobically on blood agar, some strains of *S. pneumoniae* show *beta*-haemolysis.

*Viridans streptococci:* These organisms which may be found in sputum are also *alpha*-haemolytic and require differentiation from *S. pneumoniae* (see later text).

#### Optochin sensitivity

Pneumococci are sensitive to optochin (ethylhydrocupreine hydrochloride). Placing a disc (5 µg) on a primary sputum culture and culturing the plate aerobically (not in CO<sub>2</sub>) can help to provide a rapid presumptive identification of *S. pneumoniae* (see colour Plate 29). The zone of inhibition should be at least 10 mm. Most viridans streptococci and other *alpha*-haemolytic streptococci are resistant to optochin. If the zone of inhibition is less than 10 mm (6 mm disc) the colonies should be tested for bile solubility (see following text).

**Chocolate and lysed blood agar:** *S. pneumoniae* grows well on chocolate (heated blood) agar and lysed blood agar. Growth is enhanced when incubated in a carbon dioxide enriched atmosphere (candle jar).

*Note:* Preparation of each culture medium is described in Appendix 1.

#### Biochemical tests

*S. pneumoniae* is:

- Catalase negative (see subunit 7.5.2)
- Sensitive to optochin (see previous text)
- Bile soluble (see subunit 7.5.1)\*

#### \*Bile solubility test

There are several ways of testing pneumococci for bile solubility. The test described in subunit 7.5.1 is a tube technique, the results of which are easy to read. Some workers, however, prefer to test suspect *alpha*-haemolytic colonies directly on a culture plate by touching a colony with a loopful of 2% sodium deoxycholate reagent (pH.7.0), incubating the plate at 35–37°C for 30 minutes, and examining for lysis (disappearance of the colony, indicating *S. pneumoniae*).

#### Direct detection of pneumococcal antigen in body fluid

Rapid latex and coagglutination tests are available to detect capsular pneumococcal antigen in c.s.f., pleural fluid, serum and urine.

#### Availability

A latex reagent to detect *S. pneumoniae* capsular antigen (*Pastorex meningitis S. pneumoniae*) is available from Bio-Rad Laboratories (see Appendix 11), code 61614.

#### Antimicrobial susceptibility

Antibiotics with activity against pneumococci include penicillin, erythromycin, and co-trimoxazole. Penicillin-resistant strains are becoming an increasing problem in tropical Africa, South Africa, and elsewhere.

When testing for susceptibility to penicillin it is best to use a disc containing 1 µg of oxacillin. A zone size less than 20 mm indicates reduced susceptibility. Isolates should also be tested for susceptibility to tetracycline, erythromycin and chloramphenicol.

#### FURTHER INFORMATION

Readers are referred to WHO/CDC/USAID publication *Manual for the laboratory identification and antimicrobial susceptibility testing of bacterial pathogens of public health importance in the developing world*, 2003 (E-mail cdsdoc@who.int).

### Viridans streptococci

Although often *alpha*-haemolytic on blood agar, the viridans group of streptococci can also be non-haemolytic and occasionally *beta*-haemolytic. They form part of the normal microbial flora of the upper respiratory tract (particularly oropharynx) and gastrointestinal tract. They may therefore be found with *S. pneumoniae* in sputum (as commensals). A few species are pathogenic (e.g. *S. mutans*, *S. sanguis*, *S. mitior*) causing endocarditis, bacteraemia, and dental caries.

The following are the main features which differentiate *S. pneumoniae* from viridans streptococci:

Features	<i>S. pneumoniae</i>	<i>Viridans streptococci</i>
Haemolysis	<i>Alpha</i>	<i>Alpha, beta,</i> non-haemolytic
Optochin	Sensitive	Resistant
Bile Solubility	Positive	Negative

The *S. anginosus* group (formerly *S. milleri* group) is associated with deep abscesses in various sites in the body (abdomen, chest, brain) often in association with other bacteria.

### Anaerobic streptococci and cocci

Most of the pathogenic Gram positive anaerobic streptococci and cocci belong to the genus *Peptostreptococcus*. There is, however, no clear classification of this group of anaerobes and when isolated, they are usually reported as 'anaerobic streptococci or cocci'.

Anaerobic streptococci and cocci can be found as commensals on the skin and in the mouth, vagina and gastrointestinal tract. As pathogens they can cause septicaemia, puerperal sepsis, and bone and joint infections. They are often isolated together with other anaerobes such as *Bacteroides fragilis*, from abscesses and deep infected wounds and ulcers. Many strains are proteolytic and gas (H<sub>2</sub>S)-producing which gives infected material and cultures an unpleasant smell.

Anaerobic streptococci and cocci can be cultured in thioglycollate broth. On subculture to blood agar, the colonies are very small, shiny, and non-haemolytic. Incubation for up to 72 hours is often required to produce visible growth. Microscopically they appear as Gram positive cocci in chains, groups, or singly, variable in size, and catalase negative.

Anaerobic cocci are usually susceptible to penicillin, and all are susceptible to metronidazole 5 µg disc).

## 7.18.5 *Enterococcus* species

### Pathogenicity

*E. faecalis* (formerly classified *Streptococcus faecalis*) is the main pathogen in the genus *Enterococcus*, causing about 95% of enterococcal infections including infections of the urinary tract, biliary tract, ulcers (e.g. bed sores), wounds (particularly abdominal) and occasionally endocarditis or meningitis. It is a normal commensal of the vagina and intestinal tract. A minority of infections are caused by *E. faecium*.

### LABORATORY FEATURES

#### Morphology

*Enterococcus* species are Gram positive cocci, occurring in pairs or short chains. They are non-capsulate and the majority are non-motile.

#### Culture

Enterococci are aerobic organisms capable of growing over a wide temperature range, 10–45 °C.

**Blood agar:** Enterococci are mainly non-haemolytic but some strains show *alpha* or *beta*-haemolysis.

**MacConkey and CLED agar:** *E. faecalis* ferments lactose, producing small dark-red magenta colonies on MacConkey agar and small yellow colonies on CLED (cysteine lactose electrolyte-deficient) agar.

*Enterococcus* species are also able to grow in the presence of 6.5% sodium chloride and 40% bile. When grown on media containing aesculin, enterococci hydrolyze the aesculin, producing black colonies.

*Note:* The preparation of each culture medium is described in Appendix 1.

### Biochemical tests

*Enterococcus* species:

- Ferment lactose (also mannitol and other sugars).
- Hydrolyze aesculin (see subunit 7.5.7)
- Reduce litmus milk (see subunit 7.5.7)

*Note:* Like streptococci, enterococci are catalase negative.

#### Lancefield group

Enterococci possess Lancefield Group D antigen (as also some streptococci). The Group D antigen of enterococci is unlike that of other Lancefield groups. It is not extracted by traditional acid extraction techniques. Enzyme techniques based on Maxted's enzyme are often required. *E. faecalis*, however, is usually identified culturally and biochemically.

#### Antimicrobial susceptibility

Most enterococci are susceptible to ampicillin and resistant to cephalosporins.

Resistance is shown against penicillin. Vancomycin and ampicillin resistance appear to be emerging, associated particularly with hospital infections.

## 7.18.6 *Bacillus anthracis*

### Pathogenicity

*B. anthracis* causes anthrax which is mainly a disease of sheep, cattle, goats and other herbivores with humans becoming infected only after coming into contact with infected animals or their skins.

### Anthrax in animals

Animals become infected by ingesting *B. anthracis* when feeding. The disease is usually diagnosed after death when large numbers of bacilli can be found in the blood. Pastureland that has become contaminated with spores from excreted bacilli or from the bodies of dead animals (highly infectious) can remain a source of infection for many years, e.g. 50–60 y.

### Sources of anthrax in humans

Anthrax occurs in parts of Africa and Asia among cattle, sheep and goat-rearing people, particularly when vaccination and other preventive measures are not carried out. Herdsmen and those involved in slaughtering animals and treating skins are most at risk. Human infections (zoonoses) can occur from handling infected animals or coming into contact with skins containing anthrax spores, e.g. when using skins as clothing, water-carrying containers, or sleeping mats. Other sources of infection include animal hair, bones, and the bedding of infected animals. Less commonly, infection is caused by eating infected meat.

Depending on the source and site of infection, *B. anthracis* can cause:

- *Cutaneous anthrax* (commonest form): Bacilli enter damaged skin, producing a blister ('malignant pustule') which usually ulcerates and eventually forms a dry black scab surrounded by oedema. Fatal septicaemia, toxæmia, and meningoen­cephalitis may develop, especially in non-immune persons. Ocular anthrax may also occur.
- *Pulmonary anthrax*: Caused by inhaling large numbers of *B. anthracis* spores ('wool­sorters' disease). Infections are usually fatal.
- *Enteric anthrax*: A severe form of gastroenteritis with fever, abdominal pain and bloody diarrhoea, due to ingesting infected meat. Septicaemia often develops.
- *Meningoen­cephalitis*: Usually as a complication of septicaemia and occasionally as primary anthrax meningoen­cephalitis.

### Virulence factors

*B. anthracis* produces a polypeptide capsule which is

antiphagocytic and a toxin which affects the central nervous system leading to respiratory distress, shock, cardiac collapse and death.

### LABORATORY FEATURES

*Specimens*: Include fluid aspirated from cutaneous lesions and when indicated, sputum, cerebrospinal fluid, and blood for culture.

*Caution*: *B. anthracis* is a high risk infectious pathogen, therefore handle specimens and infected material with care, wearing protective gloves and face mask, and following recommended safety procedures. Use 4% v/v formalin solution to decontaminate infected material and laboratory-ware.

### Morphology

*B. anthracis* is a large,  $5\text{--}8 \times 1.5 \mu\text{m}$ , Gram positive (or Gram variable) non-motile bacillus, often appearing joined end to end in chains.

*In smears from specimens*: Bacilli are capsulated. The capsular material often appears irregular and fragmented. When stained using Loeffler's polychrome (McFadyean) methylene blue (see subunit 7.3.7), the bacilli stain blue and the capsular material stains purple-pink as shown in colour Plate 55.

Giesma stain can also be used when MacFadyean methylene blue is not available.

*In smears from aerobic cultures*: Bacilli are non-capsulated but contain oval spores (same diameter as the bacilli), giving the organisms a beaded appearance. They occur in chains.

### Fixation of smears

*B. anthracis* is not killed by heat-fixation. Smears should be chemically fixed by immersing the dry smears in a container of potassium permanganate 40 g/l solution (Reagent No. 71) for 10–15 minutes.

**Important:** When organisms resembling *B. anthracis* are seen in smears, specimens should be sent for further testing to the nearest Public Health Laboratory and public health officials notified as soon as possible.

**Culture**

*B. anthracis* grows aerobically and anaerobically (facultative anaerobe). The temperature range for growth is 12–45 °C with an optimum of 35–37 °C. Spore formation is best between the range 25–30 °C.

**Blood agar:** *B. anthracis* produces large 2–5 mm in diameter, grey-white, irregular colonies with wavy edges. The colonies are non-haemolytic or only slightly haemolytic. Saprophytic *Bacillus* species are markedly haemolytic.

**Broth cultures:** They are not usually turbid, but they often show a thick skin (pellicle) and a sediment.

**Gelatin stab culture:** Occasionally this is used to assist in the identification of *B. anthracis*. The organism slowly liquefies the gelatin along and out from the line of inoculation. The tree-like pattern formed by the liquefaction lines is characteristic of *B. anthracis*, but the reaction is slow and in practice anthrax bacilli are usually identified microscopically by their morphological appearance.

**Antimicrobial susceptibility**

Antibiotics with activity against *B. anthracis* include penicillin, tetracycline, streptomycin, and co-trimoxazole. Workers at risk of infection should be vaccinated.

***Bacillus cereus***

*B. cereus* toxin causes food-poisoning. The toxin is produced when the bacilli sporulate, usually in rice or other cereals that have been cooked and then stored in warm temperatures. Occasionally *B. cereus* causes opportunistic infections in immunocompromised persons, e.g. pneumonia, bacteraemia, wound infections.

*B. cereus* unlike *B. anthracis* is motile, non-capsulate, and produces haemolytic colonies on blood agar. The organism is non-lactose fermenting, producing pale colonies on MacConkey agar. On egg-yolk agar, *B. cereus* gives a strong lecithinase reaction. It rapidly liquefies gelatin stabs.

Mannitol egg-yolk phenol-red polymyxin agar (MYPA) is recommended as a selective medium for the isolation of *B. cereus* from faeces, vomit, or food. After overnight incubation at 35–37 °C, large 3–7 mm flat, dry grey-white colonies surrounded by an area of white precipitate are produced.

*B. cereus* produces beta-lactamase and is resistant to penicillin and cephalosporins. Antimicrobials with activity against *B. cereus* include gentamicin, erythromycin, vancomycin and clindamycin.

**7.18.7 *Corynebacterium diphtheriae*****Pathogenicity**

*C. diphtheriae* causes:

- Nasal, nasopharyngeal and tonsillar diphtheria, especially in young children. Often there is marked oedema of the neck. Infection is by inhaling respiratory droplets.

**Exotoxin**

Virulent strains of *C. diphtheriae* produce a powerful exotoxin that is absorbed through the damaged mucous membrane into the blood circulation. If not neutralized by antitoxin, the toxin can cause toxæmia with fatal cardiac and neural complications. Exotoxin production is dependent on a particular bacteriophage possessed by virulent strains of *C. diphtheriae*.

**Inflammatory membrane**

At the site of infection there is an acute inflammatory response which leads to the formation of a grey-yellow membrane which becomes necrotic at a later stage. If this membrane extends downwards to the larynx it can block the passage of air and cause death from asphyxia.

- Cutaneous (skin) diphtheria which usually develops when *C. diphtheriae* infects open wounds. Infection of the skin rarely leads to the serious complications associated with diphtheria of the throat.

**Note:** In many developing countries there is a high prevalence of skin diphtheria, especially in rural areas. This provides immunity to *C. diphtheriae* early in life and is thought to account for the low incidence of throat diphtheria in some areas.

***C. diphtheriae* biovars**

There are four biovars (biotypes): *gravis*, *intermedius*, *mitis*, and *belfanti*. Originally these names were used to describe the severity of disease. It is now known that toxigenic and non-toxigenic strains occur in all *C. diphtheriae* biovars. In the investigation of diphtheria, it is not necessary to differentiate these biovars.

**Note:** Commensal diphtheroids form part of the normal microbial flora of the upper respiratory tract and skin.

**LABORATORY FEATURES**

**Important:** Because of the powerful and rapidly fatal exotoxin produced by *C. diphtheriae*, a patient suspected of having diphtheria is treated immediately with antitoxin. The role of the laboratory is to confirm the clinical diagnosis.

**Specimens:** Include throat, and, or nasopharyngeal

swabs to confirm a diagnosis of throat diphtheria, and a skin swab if cutaneous diphtheria is suspected.

### Morphology

*C. diphtheriae* is Gram positive but usually stains unevenly and weakly. It is markedly pleomorphic. Long, thin, and curved forms can be seen and also short rods and rods enlarged at one end (club-shaped). They often appear in clusters, joined at angles like Chinese letters as shown in colour Plate 33.

**Commensal diphtheroids:** These are strongly Gram positive and stain uniformly. They are usually short and show little variation in size and form.

### *Volutin granules*

In Albert stained smears, particularly from Loeffler serum or Dorset egg cultures, *C. diphtheriae* often appears beaded due to the presence of dark-staining granules in the rods (see colour Plate 32). These granules, known as volutin or metachromatic granules, are energy-storing inorganic polyphosphate units. In some strains the granules form at the ends of the rods. In toluidine blue stained smears, the organisms stain pale blue and the granules dark red-purple.

*C. diphtheriae* is non-capsulate, non-motile, and does not form spores.

### Culture

*C. diphtheriae* is an aerobe and facultative anaerobe. Temperature range for growth is 20–40 °C with an optimum of 35–37 °C.

**Loeffler serum medium and Dorset egg medium:** *C. diphtheriae* grows rapidly on these media, producing significant growth in 4–6 hours. The characteristic morphological features of *C. diphtheriae*, especially granule formation, are well developed.

**Note:** It is not advisable to use either Dorset egg or Loeffler serum medium as a primary medium for isolating *C. diphtheriae* because commensal diphtheroids may overgrow the diphtheria bacteria.

**Tellurite blood agar:** This medium is widely used as a primary medium for isolating *C. diphtheriae* from throat and nasopharyngeal swabs.

*C. diphtheriae* reduces tellurite and produces grey or grey-black colonies measuring 0.5–2 mm in diameter after 24–48 h incubation, see colour Plate 30. There is considerable variation in colonial appearance.\*

\*Single colonies are generally darker or blacker than those massed together. Some strains are raised and cone-shaped (especially *mitis*), others are raised with striated margins and grey centres (especially *gravis*), and others are small with black centres and clear margins (especially *intermedius*). Strains can be haemolytic, slightly haemolytic, or non-haemolytic. *Mitis* strains are *beta*-haemolytic.

Commensal diphtheroid colonies are grey, non-haemolytic, and measure 0.1–0.8 mm in diameter. Separate colonies are generally paler than those massed together. Some staphylococci and streptococci also produce black colonies on tellurite blood agar.

**Tinsdale medium:** After 24–28 h incubation, *C. diphtheriae* colonies are grey-black, raised, and surrounded by a dark brown area as shown in colour Plate 31. The brown colour is due to the hydrogen sulphide produced from the cystine interacting with the tellurite.

Occasionally commensal diphtheroids and other respiratory tract commensals may grow on Tinsdale's medium but the colonies are not surrounded by a brown halo like those of *C. diphtheriae*. *Proteus* species produce large colonies with a blackening in the medium.

In developing countries, Tinsdale medium is less frequently used than tellurite blood agar for the isolation of *C. diphtheriae* because it is expensive (in dehydrated ready-to-use form and also individual ingredients) is more difficult to make, and is less stable. Tinsdale medium in addition to tellurite also contains cystine which makes it more differential for *C. diphtheriae* (browning is produced in the medium).

**Note:** Preparation of each culture medium is described in Appendix 1.

### Biochemical tests

*C. diphtheriae*:

- Catalase and nitrate positive (see subunit 7.5.2).
- Oxidase negative (see subunit 7.5.8).
- Urease negative (see subunit 7.5.9).
- Ferments glucose and maltose with acid production (see following text). A few strains of *gravis* and *mitis* biovars ferment sucrose.
- *C. diphtheriae gravis* ferments starch with acid production.

### Rapid carbohydrate utilization test to identify *C. diphtheriae* and other *Corynebacterium* species

- 1 Prepare buffered indicator solutions of glucose, maltose, sucrose, and starch (Reagent No. 19).
- 2 Emulsify the growth of a pure culture of the test organism in 1 ml of buffer indicator solution (Reagent No. 18). A heavy organism suspension is required.



To obtain a pure growth, subculture the organism on a slope of Dorset egg medium or Loeffler serum medium. Incubate at 35–37°C for at least 6 hours or until a good growth is obtained. Examine Gram and Albert stained smears of the subculture to confirm that the culture is pure.

- 3 Take five small tubes (e.g. precipitin), and label them 1 to 5. Tube No. 5 is a negative control.
- 4 Pipette into each tube as follows:

Tube No:	1	2	3	4	5
ml Glucose	0.1	–	–	–	–
ml Maltose	–	0.1	–	–	–
ml Sucrose	–	–	0.1	–	–
ml Starch	–	–	–	0.1	–
ml Buffer Reagent No. 18	–	–	–	–	0.1
ml Test suspension	0.1	0.1	0.1	0.1	0.1

Note: 0.1 ml is the same as 100 µl.

- 5 Incubate the tubes at 35–37°C for 1 hour.
- 6 Look for a distinct yellow colour in the tubes indicating acid production due to carbohydrate utilization. Interpret the results as shown in the following chart.

*Control:* There should be no yellow colour in the control tube (No. 5) because this contains no carbohydrate.

#### Interpretation of carbohydrate utilization test and urease reaction of *C. diphtheriae* and *C. ulcerans*

Species	Glu	Mal	Suc	Starch	Urease
<i>C. diphtheriae gravis</i>	A	A	– <sup>1</sup>	A	–
<i>C. diphtheriae mitis</i>	A	A	– <sup>1</sup>	–	–
<i>C. diphtheriae intermedius</i>	A	A	–	–	–
<i>C. ulcerans</i> <sup>2</sup>	A	A	–	A	+

**Key:** *Glu* = glucose, *Mal* = maltose, *Suc* = sucrose, *Starch* = Starch utilization. **A** = acid production following fermentation of sugar.

#### Notes

- 1 A few strains ferment sucrose.
- 2 *C. ulcerans* is a cause of ulcerative throat infections and requires differentiation from *C. diphtheriae*. On culture *C. ulcerans* resembles *C. diphtheriae gravis*. Exotoxin it produces rarely causes serious symptoms.

### Toxigenicity (virulence) testing of *C. diphtheriae*

Diphtheria is caused by toxin-producing strains of *C. diphtheriae*. Toxigenicity of *C. diphtheriae* can be tested by the Elek gel precipitation test.

The following method is based on that given in the WHO *Guidelines for the Laboratory of Diphtheria*, LAB/81.7, 1981.

#### Elek gel precipitation test method

- 1 Using sterile forceps, soak a strip of sterile filter paper\* (10–15 × 70 mm) in diphtheria antitoxin diluted to 750 units per ml. Allow the strip to drain.

\*Whatman No. 1 or No. 3 filter paper is suitable.

- 2 Lay the strip in a sterile 9 cm diameter petri dish (free from scratches). Place the petri dish with its lid slightly raised in an incubator at 35–37°C for about 20 minutes, or until the strip is dry.
- 3 Prepare the serum culture medium by adding 3 ml of clear sterile serum (horse, rabbit, calf, or bovine) to 15 ml of sterile *cooled* (50–55°C) proteose peptone agar or Columbia agar. Mix gently avoiding the formation of air bubbles.

After adding the serum, the medium *must be completely clear* otherwise it will not be possible to see the precipitation lines which form when the toxin interacts with the antitoxin.

- 4 Pour the serum agar medium into the petri dish containing the antitoxin strip. If required, reposition the strip down the centre of the dish using sterile forceps. Allow the medium to set firmly.
- 5 Dry the surface of the medium by placing the petri dish with its lid slightly raised in a 35–37°C incubator for about 20–30 minutes, but no longer than 60 minutes.
- 6 Using a wax pencil, draw lines at right angles to the strip across the base of the petri dish to indicate where to inoculate the test and control organisms.
- 7 Using a sterile wire loop, heavily inoculate the test and control organisms (toxigenic and non-toxigenic *C. diphtheriae* strains) as shown in Fig. 7.28. It is important to position the test organism next to a known toxigenic strain, to demonstrate the joining of precipitin lines (arcs of identity).

*Control strains* (obtain from Central Public Health Laboratory). The organisms can be maintained by subculturing on Dorset egg medium or subinoculating in 16% glycerol broth. Glycerol broth cultures when stored at –20°C can be preserved for several years.

- 8 Invert the plate, and incubate at 35–37°C overnight.
- 9 Using transmitted light with the culture plate held against a dark background, look for fine white lines of precipitation (see Fig. 7.28). The precipitation lines are easily seen when viewed through a low-powered hand magnifying lens.

**Toxin-producing *C. diphtheriae*** is identified by the presence of precipitin lines and arcs of identity as shown in Fig. 7.28.

Almost all strains of *gravis* and *intermedius* biovars, and 80–90% of *mitis* strains, are toxin-producing.

*Note:* Some batches of diphtheria antitoxin may produce non-specific lines of precipitation. Batches of antitoxin should be pretested and those selected which produce no secondary lines of precipitation or only a few faint lines.

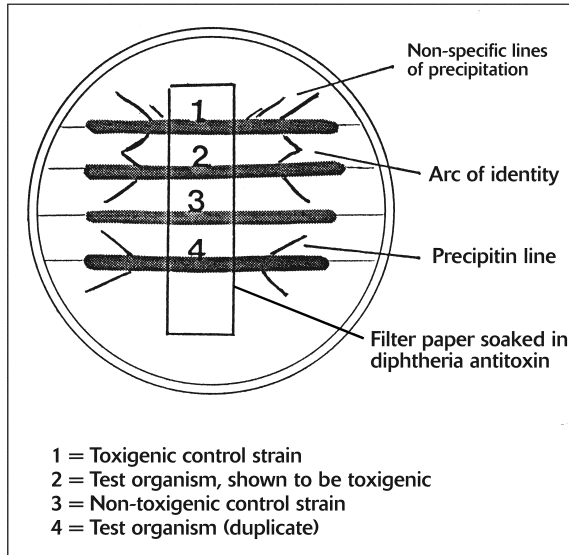

Fig 7.28 Elek plate toxigenicity test.

### Antimicrobial susceptibility

Antitoxin is used to neutralize *C. diphtheriae* toxin. Antibiotics with activity against *C. diphtheriae* include penicillin, erythromycin, clindamycin and vancomycin (susceptibility testing is rarely required).

## 7.18.8 *Listeria monocytogenes*

### Pathogenicity

*L. monocytogenes* causes meningitis and septicaemia mainly in neonates, pregnant women, the elderly and immunosuppressed persons. Listeriosis in pregnancy may lead to abortion and stillbirth. Common sources of infection are contaminated meats, chicken, soft cheeses and vegetables.

*L. monocytogenes* infects wild and domestic animals and can be found in soil, sewage and dead vegetable matter.

### LABORATORY FEATURES

*Specimens:* Mainly cerebrospinal fluid and blood for culture.

### Morphology

*L. monocytogenes* is a Gram positive non-capsulate, small rod or coccobacillus which often stains unevenly and is easily decolorized. When seen in groups it can resemble diphtheroids.

*Motility:* At 35–37°C *L. monocytogenes* is non-motile or weakly motile but at low temperature (18–22°C) it is motile with a characteristic tumbling and rotating motility in broth cultures. Motility testing is described in subunit 7.3.1.

*Cerebrospinal fluid:* In *Listeria* meningitis, only a few bacteria may be present. The c.s.f. will usually contain lymphocytes and, or, polymorphs. The c.s.f. total protein is raised.

### Culture

*L. monocytogenes* is an aerobe and facultative anaerobe. It is unusual in that it is capable of growth at refrigeration temperatures. The temperature range for growth is 3–45°C with an optimum of 30°C.

**Blood agar:** *L. monocytogenes* produces small, grey, translucent drop-like colonies surrounded by a small zone of indistinct *beta*-haemolysis (unlike streptococci, *Listeria* are catalase positive). Incubation for up to 48 h may be required to produce visible growth. Check the morphology of the colonies by examining a Gram smear.

**Clear tryptose agar** (or Mueller Hinton agar): Colonies appear pale blue-green when viewed from the side (45° angle) with a beam of white light. The bacteria act as a diffraction grating, reflecting back the blue part of the spectrum.

### Biochemical reactions

*L. monocytogenes:*

- Catalase positive
- Indole, oxidase and urease negative.
- Ferments glucose and maltose with acid production.

*Note:* The characteristic motility and cultural charac-

teristics of *L. monocytogenes* are usually sufficient to identify it without the need to use many biochemical tests.

### Antimicrobial susceptibility

Antibiotics with activity against *L. monocytogenes* include ampicillin, penicillin (less effective) and tetracycline. Usually *L. monocytogenes* is also susceptible to kanamycin and gentamicin. *Listeria* infections frequently respond to treatment with a combination of ampicillin and gentamicin.

### *Erysipelothrix rhusiopathiae*

*E. rhusiopathiae* infects pigs and other animals, also fish and birds. In humans it causes a rare skin disease called erysipeloid (cellulitis) mainly in farm workers, fish handlers and butchers. The hands are mainly affected although infections can also lead to bacteraemia.

In smears, *E. rhusiopathiae* appears as a long thin Gram positive rod, sometimes beaded. It is non-motile. It grows best on blood agar in a carbon dioxide enriched atmosphere at 30–35°C (also grows anaerobically). Small *alpha*-haemolytic colonies are produced (using horse blood). The following tests differentiate *E. rhusiopathiae* from *L. monocytogenes* and *Corynebacterium* species.

Species	Motility	Cat	H <sub>2</sub> S <sup>3</sup>
<i>E. rhusiopathiae</i>	–	–	+
<i>L. monocytogenes</i>	+ <sup>1</sup>	+	–
<i>Corynebacterium</i> sp	–	+ <sup>2</sup>	–

**Key:** Cat = Catalase test, H<sub>2</sub>S = Hydrogen sulphide produced.

- 1 Rotating, tumbling motility at 18–22°C.
- 2 A few *Corynebacterium* species are catalase negative.
- 3 This can be tested using Kligler iron agar.

Antibiotics with activity against *E. rhusiopathiae* include penicillin, cephalosporins, and erythromycin. The organism is resistant to kanamycin and gentamicin.

## 7.18.9 *Clostridium perfringens*

### Types of *C. perfringens*

Based on surface antigens and major toxins produced, five types of *C. perfringens* (A–E) are recognized. Human disease is caused by types A and C (other types cause disease in animals). All types produce *alpha* toxin, a major lethal toxin. Type C strains also produce *beta* toxin (see following text).

### Pathogenicity

- *C. perfringens* type A1: Causes gas gangrene (myonecrosis), anaerobic cellulitis, puerperal infection and septicaemia.

### Gas gangrene

Under anaerobic conditions, *C. perfringens* multiplies and produces *alpha* toxin and other toxins which result in the rapid destruction of tissue carbohydrate with the production of gas in decaying tissues, particularly muscle. Affected tissue is foul-smelling. Septicaemia can lead to intravascular haemolysis. *Alpha* toxin (phospholipase-C) is the main cause of cell lysis and toxemia. Gas gangrene occurs following the infection of wounds, particularly tissue with a poor blood supply. *C. perfringens* and its spores are naturally found in the gut of humans and animals, in soil (particularly when contaminated with faeces), and water.

*Note:* Other species of *Clostridium* that occasionally cause gas gangrene include *C. novyi* and *C. septicum*.

- *C. perfringens* type A2: Causes food-poisoning, usually within 8–12 hours of ingesting contaminated meat. Ingested *C. perfringens* sporulate in the small intestine, releasing a heat-labile enterotoxin which acts mainly on the membrane permeability of the small intestine. Most infections are self-limiting and do not usually require laboratory diagnosis.
- *C. perfringens* type C: Causes a severe form of jejunitis (necrotizing enterocolitis), known as pigbel. The source of infection is usually insufficiently cooked pig meat. Pigbel occurs in China, Highlands of Papua New Guinea, Solomon Islands, Bangladesh and parts of East Africa. The condition is often fatal especially in young children.

### Pigbel

Following ingestion, *C. perfringens* C multiplies in the small intestine, producing *beta*-toxin which causes severe intestinal damage with abdominal pain, dysentery, and vomiting. Toxin activity is helped by eating sweet potatoes, peanuts and other foods containing protease inhibitors (prevent toxin from being destroyed). Those heavily infected with *Ascaris lumbricoides* are also at risk of developing pigbel.

### LABORATORY FEATURES

*Specimens:* Include material from wounds, necrotic tissue, and exudate to investigate gas gangrene, and faeces and suspected food to investigate food-poisoning.

### Morphology

*C. perfringens* is a non-motile Gram positive thick brick-shaped rod as shown in colour Plate 34. Spores are rarely seen in smears from infected tissue. Some strains are capsulate in tissue. Pus cells, if seen, usually appear damaged due to toxin action. Often other bacteria are also present.

### Culture

*C. perfringens* is a facultative anaerobe which can be cultured, both anaerobically and microaerophilically. Optimum temperature range is 37–45 °C.

**Blood agar:** Large *beta*-haemolytic colonies are produced (most food-poisoning strains are non-haemolytic). Some strains produce a double zone of haemolysis as shown in colour Plate 36.

#### *Neomycin blood agar*

This selective medium (see No. 16) is recommended for the isolation of *C. perfringens* from sites likely to contain several organisms, e.g. from wounds. When incubated anaerobically, the growth of facultative Gram negative rods is inhibited.

#### **Robertson's cooked meat medium (RCMM):**

In this medium *C. perfringens* is saccharolytic and slightly proteolytic. Gas is formed.

#### **Saccharolytic and proteolytic reactions in RCMM**

A saccharolytic reaction is shown by reddening of the meat with a rancid smell due to carbohydrate decomposition. A proteolytic reaction is shown by blackening of the meat with a very unpleasant smell due to protein decomposition.

*Note:* Preparation of each culture medium is described in Appendix 1.

#### *C. perfringens* food-poisoning

When suspected, before incubating the inoculated RCMM, place it in a beaker or bath of boiling water for 90 minutes. This will destroy vegetative faecal organisms but not the spores of most food-poisoning strains of *C. perfringens*. Following overnight incubation at 35–37 °C, subculture on blood agar and incubate anaerobically for 24–48 h.

#### Biochemical tests

Clostridia are catalase and oxidase negative. The most useful biochemical reactions which help to identify *C. perfringens* and other pathogenic *Clostridium* species can be tested by culturing the organism anaerobically on lactose egg yolk medium (see No. 47). This medium tests for lecithinase C activity, lipase hydrolysis, lactose fermentation and proteinase activity.

**Lecithinase C activity:** Seen as an opacity in the medium due to the breakdown of lecithin in the egg yolk.

**Lipase hydrolysis:** Seen as a pearly (fatty) layer covering colonies and sometimes extending into the medium. A restricted intense area of opacity is also produced in the medium.

**Lactose fermentation:** There is a reddening in the medium. The colonies become red on exposure to air.

**Proteinase activity (proteolysis):** Shown by an area of clearing around the colonies due to the breakdown of casein in the milk by the enzyme proteinase.

On lactose egg yolk medium, *C. perfringens*:

- Produces lecithinase C (*alpha* toxin)
- Ferments lactose
- Does not hydrolyze lipid
- Shows no proteinase activity

*Note:* Colour Plate 35 shows the reactions of *C. perfringens* on lactose egg yolk medium. The following table summarizes the reactions of *C. perfringens* and other pathogenic *Clostridium* species on lactose egg yolk milk agar.

Species	Lecith	Lip	Lact	Prot
<i>C. perfringens</i> A–E	+	–	+	–
<i>C. novyi</i> A <sup>2</sup>	+	+ <sup>1</sup>	–	–
<i>C. sordellii</i> <sup>2</sup>	+	–	–	+
<i>C. histolyticum</i> <sup>1,2</sup>	–	–	–	+
<i>C. septicum</i> <sup>2</sup>	–	–	+	–
<i>C. difficile</i> <sup>3</sup>	–	–	–	–
<i>C. tetani</i> <sup>4</sup>	–	–	–	–
<i>C. botulinum</i> : <sup>5</sup> types A, B, F	–	+	–	+
types C, D, E	–	+	–	–

**Key:** *Lecith* = Lecithinase C activity, *Lip* = Lipase hydrolysis, *Lact* = Lactose fermentation, *Prot* = Proteinase activity.

#### Notes

- 1 The diffuse lecithinase opacity hides the restricted lipase opacity.
- 2 Occasionally a cause of gas gangrene or contributes to it.
- 3 Causes antibiotic-associated diarrhoea and pseudomembranous colitis. Diagnosis is usually made by detecting *C. difficile* antigen in a faecal specimen using a latex agglutination test or a test to detect toxin in faeces.
- 4 Causes tetanus, see subunit 7.18.11.
- 5 Causes botulism, see subunit 7.18.10.

#### Nagler reaction

As explained in the previous text, *C. perfringens* produces an opacity in medium containing lecithin due to lecithinase C activity (*alpha* toxin). This opacity can be inhibited by applying specific anti-toxic serum to the medium which will inactivate the lecithinase. The technique is referred to as the Nagler reaction.

**Method of performing Nagler test**

- 1 Prepare a plate of lactose egg yolk milk agar (see No. 47).\*  
\*The Nagler reaction can also be demonstrated using serum agar or egg yolk agar, but lactose egg yolk milk medium is preferred because it differentiates *C. perfringens* (lactose fermenting) from other clostridia that give a positive Nagler reaction (see later text).
- 2 Turn the plate over, and using a wax pencil, draw a line across the centre of the plate.
- 3 Using a sterile swab, cover one half of the medium with *C. perfringens* antitoxin.\* Allow to dry.  
\**C. perfringens* A antitoxin can be obtained from Pro-Lab Diagnostics (see Appendix 11), code PL6506 for 5 ml. It has a shelf-life of 1 year or more.
- 4 Inoculate the test organism at right angles to the centre line so that the inoculum passes from the antitoxin-free half of the plate to the antitoxin-covered half.  
Inoculate also a non-toxin producing control organism that will grow anaerobically.
- 5 Incubate the plate anaerobically at 35–37°C overnight.
- 6 Look for an opacity around the inoculum in the half of the plate containing no antitoxin and no opacity in the half containing the antitoxin.

A positive Nagler reaction is shown in Plate 7.34.

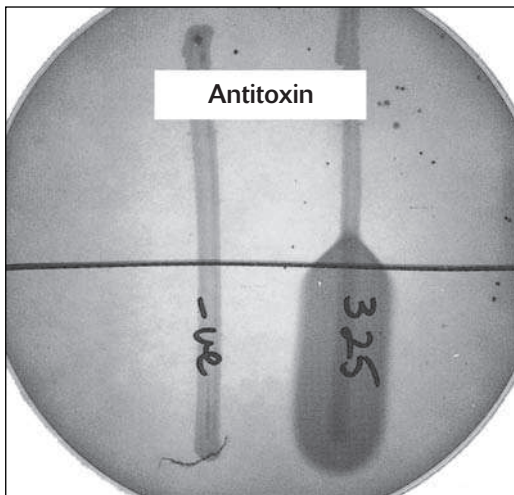

Plate 7.34 *Clostridium perfringens* showing positive Nagler reaction on serum agar. (See also colour Plate 35).  
Courtesy of RW Davies.

**Note:** Besides *C. perfringens*, other clostridia that give a positive Nagler reaction include *C. bifermentans*, *C. sordellii*, and *C. baratii*. The latter species is very rarely isolated from clinical specimens, and the other two species are non-lactose fermenters whereas *C. perfringens* is a lactose fermenter.

**Reverse CAMP test**

Because of the difficulty in obtaining *C. perfringens* A antitoxin to use in the Nagler reaction, some laboratories use a reverse CAMP technique to assist

in the identification of *C. perfringens*.

**Method of performing a reverse CAMP test**

- 1 Inoculate a streak of the test organism on a blood agar plate.
- 2 Make a streak of a group B *beta*-haemolytic *Streptococcus* at right angles to, and within 1–2 mm of the test organism streak (do not allow it to touch).
- 3 Following overnight anaerobic incubation, look for an arrow of haemolysis pointing from the *Streptococcus* to the test organism. If present this indicates a positive reverse CAMP test.

**Note:** False positive and false negative reactions have been reported.

**7.18.10 Clostridium botulinum****Pathogenicity**

*C. botulinum* causes a rare and usually fatal food-borne disease called botulism in which a lethal preformed neurotoxin is ingested. The toxin causes paralysis usually 12–36 h after ingestion. Death usually occurs from respiratory failure. Rarely *C. botulinum* causes infantile botulism in which the bacteria colonize the gut of infants and produce toxin which is absorbed. The condition is usually fatal.

***C. botulinum* toxins**

There are seven toxin types (A–G). Human botulism is usually caused by toxin types A, B, E and rarely type F. The toxin is formed in food when *C. botulinum* spores contaminate food. Under anaerobic conditions, e.g. in tinned meat or fish (not acid fruits), the spores germinate and the bacilli multiply, producing toxin. *C. botulinum* can be found in soil, water, and sewage.

**LABORATORY FEATURES**

**Important:** Public health officials must be notified as soon as possible if botulism is suspected and tests to confirm the disease carried out in a Public Health reference laboratory, i.e. tests to detect the toxin. Antitoxin needs to be administered to neutralize the absorbed toxin.

**Specimens:** Include suspected food and patient's faeces and serum (to demonstrate toxin).

**Morphology**

*C. botulinum* is a Gram positive, motile, pleomorphic rod with oval sub-terminal spores. It is rarely isolated from specimens.

**Culture and biochemical reactions**

*C. botulinum* is a strict anaerobe. Grows best at 30–35 °C.

**Robertson's cooked meat medium (RCMM):** Inoculate the emulsified specimen (in 0.1% peptone water) in several containers of RCMM. Heat half of them at 80 °C for 30 minutes (spores remain). Incubate the heat-treated and untreated inoculated RCMM at 35 °C for 3–5 days. Types A, B and F blacken and digest cooked meat medium (proteolytic reaction) and produce hydrogen sulphide gas (types C, D, and E do not).

**Blood agar subculture from RCMM (anaerobic culture):** *C. botulinum* produces large semi-transparent colonies with a wavy outline. Most strains are *beta*-haemolytic.

**Lactose egg yolk milk agar, (see subunit 7.18.9):** *C. botulinum* hydrolyzes lipid (pearly opalescence). Types A, B, and F show proteinase activity (area of clearing around the colonies). Lactose is not fermented (see Table at the end of subunit 7.18.9).

*Note:* Preparation of each culture medium is described in Appendix 1.

*Note:* *C. botulinum* toxin detection tests and details of other laboratory procedures used to investigate botulism can be found in microbiology textbooks (see Recommended Books on p. 379).

## 7.18.11 *Clostridium tetani*

**Pathogenicity**

*C. tetani* causes tetanus, a serious often fatal disease caused by the neurotoxin (tetanospasmin) produced by *C. tetani* when it multiplies in the tissues. The toxin causes muscular rigidity and spasms, difficulty in opening the jaw ('lock-jaw') and backward arching of the back due to contractions of back muscles.

Infection occurs when *C. tetani* spores from contaminated soil enter puncture wounds and after a latent period of several weeks or months, germinate under anaerobic conditions. A toxoid vaccine is available to prevent the disease.

**Neonatal tetanus**

In parts of Africa and Southeast Asia, tetanus is a major cause of death in newborn infants. It occurs when the umbilical stump becomes infected due to the cord being cut with a contaminated blade, or when animal dung (containing large numbers of *C. tetani* spores) is applied to the cord stump.

**FURTHER INFORMATION**

**Vandelaer J *et al.*** Tetanus in developing countries: an update on the maternal and neonatal tetanus elimination initiative. *Vaccine*, July 28; 21(24), 2003.

**Oladiran I *et al.*** Tetanus: continuing problem in the developing world. *World Journal Surgery*, 26, pp. 1282–5, 2002.

**LABORATORY FEATURES**

Most patients with tetanus can be diagnosed clinically. Occasionally laboratory investigation may be required.

**Morphology**

*C. tetani* is a Gram positive, non-capsulate rod that forms spores. Most strains are motile (type 6 is non-motile). It can sometimes be seen in Gram smears of exudate from wounds, appearing as a long thin Gram positive (weakly staining) rod with a rounded unstained spore at one end.

**Culture**

*C. tetani* is a strict anaerobe with a temperature range of 14–43 °C (37 °C optimum).

**Blood agar:** When isolated (only very occasionally), *C. tetani* produces a fine film of feathery growth. Use a hand lens to examine the plate. On fresh blood agar, *C. tetani* is haemolytic (*alpha* first followed by *beta* haemolysis).

**Antitoxin test**

If growth occurs, subculture on a blood agar antitoxin plate (half the plate covered with antitoxin). Incubate the plate anaerobically. The haemolysis produced by *C. tetani* is inhibited by the antitoxin.

**Robertson's cooked meat medium (RCMM):**

*C. tetani* is slowly proteolytic. If clostridial growth occurs (check a Gram smear), divide the culture and heat one half at 80 °C for 30 minutes and cool. Subculture both the unheated and heated cultures on fresh blood agar and incubate anaerobically.

**Biochemical tests**

*C. tetani* is indole positive. It can be identified presumptively by the blood agar antitoxin test (see previous text).

## 7.18.12 *Neisseria meningitidis*

***N. meningitidis* serogroups:** Based on capsular polysaccharide antigens, more than 13 meningococcal serogroups have been identified. Infections are caused mainly by groups A, B, C, Y, X and W135 with groups A and C and less commonly group B, being responsible for epidemics.

### Pathogenicity

*N. meningitidis* causes:

- Pyogenic (purulent) meningitis, usually following bacteraemia. It often has a sudden onset with intense headache, vomiting and a stiff neck. *N. meningitidis* occurs as a commensal in the nasopharynx of up to 25% or more of healthy people.

#### Meningococcal meningitis in developing countries

*N. meningitidis* is a major cause of epidemic and endemic meningitis in developing countries, particularly in sub-Saharan Africa. In what is known as the 'meningitis belt' (stretching from Senegal, the Gambia, and Guinea-Bissau in the west to Ethiopia in the east and more recently, extending south as far as Mozambique, Angola and Namibia), epidemics occur in the hot dry season, often with high loss of life, particularly among children, and young adults. In recent years, major epidemics have been reported from Burkina Faso, Chad, Ethiopia and Niger.

Up to 90% of outbreaks are due to group A meningococci. Group C has been reported as causing epidemics in Africa, Asia, and South America. Outbreaks due to group B occur in Cuba and South America and endemic meningitis due to Group B occurs in Africa and elsewhere. Outbreaks due to group W135 have been reported from Burkina Faso and among pilgrims in Saudi Arabia. Knowing the serogroup in an epidemic is important in planning vaccination.

- Meningococcal septicaemia, a severe and often fatal condition with high fever and characterized by rapid circulatory collapse and a haemorrhagic rash. Petechiae can often be detected in the conjunctivae.
- Chronic meningococcal arthritis, an uncommon condition.

### LABORATORY FEATURES

**Specimens:** Include cerebrospinal fluid, blood for culture and swabs from haemorrhagic skin lesions (of particular value in patients with septic shock without meningitis).

### Morphology

*N. meningitidis* is a non-motile Gram negative diplococcus (with joining sides flattened), often seen in groups. In smears from specimens, meningococci are found inside pus cells (intracellular) as shown in colour Plate 38. A few organisms may also be seen

lying free (extracellular), particularly when pus cells have been damaged when spreading the smear.\*

\*To avoid damaging pus cells, a swab should be gently rolled on a slide when making a smear and the preparation, methanol-fixed rather than heat-fixed.

Although meningococci are capsulate, the capsules are not evident. In smears from cultures, meningococci appear as Gram negative cocci.

### Culture

*N. meningitidis* is an aerobe with primary cultures growing best in a moist carbon-dioxide enriched atmosphere (see subunit 7.4). The temperature range of growth is 25–42 °C with an optimum of 35–37 °C. Enriched media are required for isolation. Specimens should be cultured as soon as possible after collection. Some workers also recommend inoculating c.s.f. into Robertson's cooked meat medium in addition to culturing it on chocolate agar.

**Chocolate (heated blood) agar:** *N. meningitidis* produces transparent or grey, shiny, 1–2 mm colonies after incubation in CO<sub>2</sub>. Group A and C meningococci produce larger and more mucoid colonies than group B strains. The colonies of group B meningococci often appear grey-yellow.

*Note:* *N. meningitidis* also grows on Mueller Hinton agar without the need to add blood.

**Blood cultures:** Meningococci grow well in Columbia diphasic medium (see No. 26). Because sodium polyanethol sulphonate (SPS) may be inhibitory to meningococci, some workers add sterile gelatin (1% final concentration) to neutralize the effect of SPS. Subculture a positive blood culture onto chocolate agar and incubate in a carbon-dioxide enriched atmosphere.

### Biochemical tests

*N. meningitidis* is oxidase positive.

**Presumptive diagnosis of meningococcal meningitis:** This can be made when oxidase positive colonies shown to be Gram negative cocci are isolated from c.s.f. The isolate should be serogrouped using *N. meningitidis* antisera. When the isolate cannot be grouped it should be sent to a microbiology reference laboratory for identification.

Other biochemical tests which may occasionally be required to identify *N. meningitidis* include carbohydrate utilization (glucose, maltose, sucrose, lactose),

DNA-ase, *beta*-galactosidase (ONPG) and glutamyl-aminopeptidase (GAP). These tests form part of most commercially available *Neisseria* identification kits.

#### *N. meningitidis*

- Ferments glucose and maltose but not sucrose or lactose.
- DNA-ase negative
- ONPG negative
- GAP positive

*Note:* The biochemical tests performed on c.s.f. to investigate meningitis are described in subunit 7.13.

#### Serology

Meningococcal capsular polysaccharide antigens can be found in c.s.f., serum and urine. Direct latex agglutination and coagglutination slide antigen tests are available to detect antigens to the main groups of meningococci (see subunit 7.13). Such tests are of value in epidemics when microbiological laboratory facilities are not available.

#### *Serogrouping N. meningitidis isolates (cultures)*

*N. meningitidis* antisera are expensive. Whenever possible public health laboratories should stock *N. meningitidis* Group A antiserum and if required also Group C antiserum to enable the cause of a meningococcal epidemic to be determined with the minimum of delay.

#### Availability of *N. meningitidis* antisera

Separate antisera for slide grouping *N. meningitidis*, groups A, B, and C from culture are available from Oxoid (2 ml), and Becton Dickinson (1 ml). Most antisera have a shelf-life of 1½–2 y. About 25 slide tests can be obtained from 1 ml of antiserum. Details of manufacturers can be found in Appendix 11.

#### Antimicrobial susceptibility

Most strains of *N. meningitidis* are susceptible to penicillin, ampicillin, chloramphenicol, rifampicin and ceftriaxone. Penicillin-resistant strains of meningococci have been reported from South Africa and elsewhere, and occasionally also resistance to rifampicin.

Vaccines are available against meningococcal groups A, C, Y, W135 as monovalent or polyvalent preparations. A vaccine against Group B meningococci has been developed in Cuba and other B vaccines are under development. Protection provided by the vaccines is group specific and lasts for about 3 years. Polysaccharide vaccines are generally poorly immunogenic in children under 2 years. Recently developed polysaccharide-protein conjugated vaccines are immunogenic in

very young children and provide long-lasting protection.

#### FURTHER INFORMATION

Readers are referred to the WHO Fact Sheet: *Meningococcal meningitis* accessed from the WHO website [www.who.int](http://www.who.int) (use the Search facility to locate the Fact Sheet).

## 7.18.13 *Neisseria gonorrhoeae*

#### Pathogenicity

*N. gonorrhoeae* causes:

- Gonorrhoea of the urogenital tract and less commonly, rectal and pharyngeal infection. Gonorrhoea is sexually transmitted.

#### Infection in men

In men, *N. gonorrhoeae* infects the urethra and is usually symptomatic, causing dysuria and acute urethritis with a purulent discharge. In about 95% of patients, gonococci can be found in urethral discharge or urine sediment. The organism may spread to the prostate, bladder and epididymes, causing inflammation and swelling. Epididymitis may lead to sterility. *N. gonorrhoeae*-HIV co-infection has been shown to increase the concentration of HIV in semen.

#### Infection in women

In women, *N. gonorrhoeae* infects the cervix, urethra, vulva and rectum. Rectal infection occurs in up to 40% of women with gonorrhoea. Symptoms of infection include dysuria and cervicitis with a purulent cervical discharge. However, up to 80% of infections are with few symptoms or are asymptomatic. Gonococci can be found in Gram smears in only 40–60% of infected women. Culture of a cervical specimen is usually required to diagnose or exclude gonorrhoea in women. When untreated, infection may spread upwards through the genital tract to the fallopian tubes and elsewhere in the pelvis causing salpingitis (inflammation of the tubes) and pelvic inflammatory disease (PID) which may lead to ectopic pregnancy or sterility. *N. gonorrhoeae*-HIV co-infection may facilitate the transmission of HIV and development of PID.

- Acute conjunctivitis in infants born of mothers with urogenital gonorrhoea. The eyes become infected at the time of delivery. The infection is known as ophthalmia neonatorum, and if untreated can lead to blindness. In areas of high prevalence it is usual to treat the eyes of newborns with antibiotic or silver nitrate drops.
- Vulvovaginitis in pre-pubertal girls.
- Gonococcal arthritis, as a complication of gonococcal bacteraemia. Widespread infection is more common in women. Symptoms include fever, joint pains, and rash.



*Note:* Virulent strains of *N. gonorrhoeae* possess pili which facilitate the attachment of the organism to mucosal surfaces.

## LABORATORY FEATURES

*Specimens:* Urethral and cervical exudate, urine (centrifuged) from male patients, and when indicated a rectal swab. The collection of urogenital specimens is described in subunit 7.10. An eye swab is required when gonococcal conjunctivitis of the newborn is suspected.

## Morphology

*N. gonorrhoeae* is a non-motile, non-capsulate Gram negative diplococcus, typically seen in pus cells (intracellular) but also extracellularly (see colour Plate 43). Morphologically gonococci look the same as meningococci.

**Making smears:** To avoid damaging pus cells, a swab should be gently rolled on a slide when making a smear and the preparation, methanol-fixed rather than heat-fixed.

## Culture

*N. gonorrhoeae* is an aerobe or facultative anaerobe. It is a fastidious organism which requires culturing with the minimum of delay. Some strains are unable to survive drying or temperatures below body temperature. An enriched selective medium such as modified New York City (MNYC) medium or Thayer Martin medium is required to isolate *N. gonorrhoeae* from urogenital specimens. Gonococci grow best in a moist carbon-dioxide enriched atmosphere (see subunit 7.4). Optimum temperature for growth is 35–36 °C.

## MNYC medium and Thayer Martin medium:

*N. gonorrhoeae* grows rapidly producing small, raised, grey or translucent colonies after overnight CO<sub>2</sub> incubation as shown in colour Plate 41. Examine a Gram stained smear of the colonies and perform an oxidase test (see subunit 7.5.8).

When a non-selective enrichment medium such as chocolate (heated blood) agar only is available for isolating *N. gonorrhoeae*, suspect colonies (colourless, raised, 1–2 mm in diameter) can be detected in a mixed culture by adding fresh oxidase reagent to the culture plate. *Neisseria* colonies are strongly oxidase positive and immediately turn deep purple in colour. The colonies, however, must be removed for identification and subculturing within 1–2 minutes of adding the oxidase reagent because the reagent is rapidly bactericidal.

*Note:* Preparation of MNYC and Thayer Martin media is described in Appendix 1.

## Biochemical tests

*N. gonorrhoeae* is oxidase positive.

**Presumptive diagnosis of gonorrhoea:** This can be made when oxidase positive colonies, shown to be Gram negative cocci, are isolated from a urogenital specimen using an enriched selective medium. In male patients a presumptive diagnosis can often be made by finding Gram negative diplococci in urethral exudate or urine sediment. Isolates can be identified biochemically using commercially available carbohydrate and enzyme based tests, or serologically using a *N. gonorrhoeae* coagglutination test (simpler and less expensive), see later text.

*N. gonorrhoeae*

- Ferments glucose but not maltose, sucrose, or lactose
- DNA-ase negative
- *Beta*-galactosidase (ONPG) negative
- Glutamyl-aminopeptidase (GAP), negative

*Note:* The above biochemical tests can be easily and economically performed using Rosco Diagnostic tablets (see subunit 7.5).

## Serological identification of isolates

Several rapid to perform monoclonal antibody-based slide coagglutination tests are available to identify *N. gonorrhoeae* isolates. A boiled saline suspension of the organism is used. Agglutination reactions are easy to read. Coagglutination tests for identifying *N. gonorrhoeae* isolates have been shown to be specific and highly sensitive.

## Availability of *N. gonorrhoeae* coagglutination tests

- *GC Monoclonal (Phadebact) test* is manufactured by Boule Diagnostics, code 10-6419-12. Each test kit contains 50 tests.
- *GonoGen Monoclonal antibody test* is available from BD Diagnostics, code 244000. Each test kit contains 50 tests.

*Note:* Manufacturers' contact details can be found in Appendix 11.

## Antimicrobial susceptibility

*N. gonorrhoeae* isolates require screening for *beta*-lactamase (penicillinase) production (see end of subunit 7.16). Gonococcal strains show widespread antimicrobial resistance to penicillin and other antibiotics. The resistance is plasmid mediated, e.g. penicillinase-producing *N. gonorrhoeae* (PPNG) and tetracycline-resistant *N. gonorrhoeae* (TRNG), and also chromosomally mediated, e.g. gonococcal strains resistant to penicillin, tetracycline, spectinomycin and more recently, to fluoroquinolones.

## FURTHER INFORMATION

**Van Dyck E, Meheus AZ, Piot P.** *Laboratory diagnosis of sexually transmitted diseases.* WHO, 1999. ISBN 92 4 154501 1.

Available from WHO Publications, 1211 Geneva, 27-Switzerland.

**WHO/CDC/USAID publication** *Manual for the laboratory identification and antimicrobial susceptibility testing of bacterial pathogens of public health importance in the developing world*, 2003 E-mail: cdsdoc@who.int.

## 7.18.14 *Escherichia coli*

### Enterobacteria

*E. coli* and the pathogens described in subsequent subunits 7.18.15–7.18.19 belong to the large group of Gram negative rods referred to as enterobacteria. They are naturally found in the intestinal tract, in soil and water. Those that cause primary and opportunistic infections in humans belong mainly to the following genera:

<b>Lactose fermenting</b>	● <i>Escherichia</i> <sup>1</sup>	● <i>Enterobacter</i> <sup>1,2</sup>
	● <i>Klebsiella</i> <sup>1</sup>	● <i>Citrobacter</i> <sup>1,2</sup>
<b>Non-lactose fermenting</b>	● <i>Salmonella</i>	● <i>Providencia</i> <sup>2</sup>
	● <i>Shigella</i>	● <i>Serratia</i> <sup>2</sup>
	● <i>Proteus</i>	● <i>Edwardsiella</i> <sup>2</sup>
	● <i>Morganella</i>	● <i>Hafnia</i> <sup>2</sup>
	● <i>Yersinia</i>	

- 1 Often referred to as coliforms.
- 2 Less common human pathogen, often opportunistic or hospital-acquired. For details of species in these genera, readers are referred to microbiology textbooks (see Recommended Reading).

Enterobacteria are aerobes and facultative anaerobes, non-spore and motile or non-motile. They are oxidase negative, reduce nitrate to nitrite, and ferment glucose with acid production (some also produce gas). The various biochemical tests used to identify important enterobacteria are summarized in Chart 7.10. Exotoxin (enterotoxin) is produced by *Shigella dysenteriae* and toxigenic strains of *Escherichia coli*. When lysed, enterobacteria release endotoxin from their cell wall (feature of all Gram negative rods).

### Antigens

Enterobacteria possess a wide variety of antigens which are used in serotyping, particularly salmonellae, shigellae, and *E. coli*. Cross-reactions however can occur, due to a sharing of antigens.

- *O* antigens: These are found in the bacterial cell wall. They are heat stable.
- *K* antigens: These are capsular polysaccharide antigens. They surround the cell wall and can therefore interfere with the testing of underlying O antigens (K antigens can be heat-inactivated, enabling O antigens to be detected). The K antigens of some salmonellae, e.g. *S. Typhi*, are called Vi antigens.
- *H* antigens: These are flagellar protein antigens possessed by motile enterobacteria. They are heat labile (destroyed at 60–100°C). *Salmonella* serovars often produce two different antigenic types of H antigens, called phase 1 and phase 2.

## *Escherichia coli*

### Pathogenicity

*E. coli* causes:

- Urinary tract infections. *E. coli* is the commonest pathogen isolated from patients with cystitis. Recurring infections are common in women.
- Infections of wounds, peritonitis, sepsis and endotoxin induced shock.
- Meningitis and bacteraemia in neonates. *E. coli* capsular type K1 is associated with neonatal meningitis.
- Diarrhoeal disease: infantile gastroenteritis, traveller's diarrhoea, dysentery, and haemorrhagic diarrhoea which may progress to haemolytic uraemic syndrome.

### *E. coli* strains associated with diarrhoeal disease

- ETEC (Enterotoxigenic *E. coli*): Causes watery (secretory) diarrhoea due to the production of plasmid-mediated toxins (LT, ST) in infants and adults, particularly in developing countries. It is often referred to as traveller's diarrhoea. Many serogroups are involved.
- EPEC (Enteropathogenic *E. coli*): Causes vomiting, fever, and prolonged diarrhoea mainly in infants (less than 2 y). Due to bacteria adhering to epithelial cells, multiplying and causing lesions. Many serogroups are involved. EPEC is a major problem in developing countries.
- EIEC (Enteroinvasive *E. coli*): Causes dysentery (similar to shigellosis), fever and colitis, with blood, mucus, and many pus cells in faecal specimens. Due to bacteria invading and multiplying in epithelial cells. Many serogroups are involved.
- EHEC (Enterohaemorrhagic *E. coli*): Causes life-threatening haemorrhagic diarrhoea (colitis) in all ages, without pus cells, and often without fever. It can progress to haemolytic uraemic syndrome with renal failure. EHEC has been reported mainly from Europe and North America. Outbreaks have also occurred in refugee camps in Mozambique, Swaziland and Malawi. EHEC is due to cytotoxins damaging vascular endothelial cells, and is mainly associated with the serogroup O157:H7. It is sometimes referred to as VTEC (verocytotoxin-producing *E. coli*, because it is toxic to vero monkey cells in culture). Infection occurs by ingesting contaminated meat products, unpasteurized milk and dairy products.
- EaggEC (Enteroggregative *E. coli*): Causes chronic watery diarrhoea and vomiting, mainly in children. Due to the bacteria adhering to tissue cells often in stacks (aggregates).

### LABORATORY FEATURES

*Specimens*: Depending on site of infection, specimens include urine, pus, faeces, cerebrospinal fluid (infants), and blood for culture.

**Morphology**

*E. coli* is a Gram negative usually motile rod. Inactive strains (formerly described as *Alkascens-Dispar*) are nonmotile. A minority of strains are capsulate.

**Culture**

*E. coli* is an aerobe and facultative anaerobe. Optimum temperature for growth is 36–37°C with most strains growing over the range 18–44°C.

**Blood agar:** *E. coli* produces 1–4 mm diameter colonies after overnight incubation. The colonies may appear mucoid. Some strains are haemolytic.

**MacConkey agar and CLED agar:** *E. coli* ferments lactose, producing smooth pink colonies on MacConkey agar and yellow colonies on CLED agar. Some strains (e.g. inactive strains) are late or non-lactose fermenting.

**Sorbitol MacConkey agar:** *E. coli* (VTEC) 0157 is non-sorbitol fermenting, producing colourless colonies. Most other *E. coli* strains and other enterobacteria ferment sorbitol. *E. coli* (VTEC) 0157 can be identified by testing the colonies using 0157 latex reagent (see later text).

**XLD and DCA agar:** Yellow colonies are produced on XLD agar. Growth of *E. coli* is usually inhibited on DCA agar.

**KIA** (Kligler iron agar): Most strains of *E. coli* produce an acid deep and an acid slope with gas production and no H<sub>2</sub>S blackening (similar to other lactose fermenting coliforms).

*Note:* Preparation of each culture medium is described in Appendix 1.

**Biochemical reactions**

Most strains of *E. coli*:

- Indole positive (see subunit 7.5.6)
- Lysine decarboxylase (LDC) positive.
- *Beta*-glucuronidase (PGUA) positive (*E. coli* 0157 is PGUA negative).
- Reduce nitrate to nitrite, giving a positive urine nitrite test.
- Citrate and H<sub>2</sub>S negative.

Other biochemical reactions of *E. coli* are shown in Chart 7.10.

*Note:* Some *E. coli* strains give biochemical reactions similar to *Shigella* species, i.e. they are non-motile, late or non-lactosing fermenting, and non-gas producing.

**Identification of *E. coli* strains and toxin testing**

The facilities of a specialist microbiology laboratory are required for serogrouping *E. coli* and when required, testing for toxins. When infection with EHEC 0157 is suspected (haemorrhagic colitis), a presumptive diagnosis can be made by isolating sorbitol non-fermenting *E. coli* on sorbitol MacConkey agar. The colonies can be identified as *E. coli* 0157 by testing with specific 0157 antiserum, available as a latex agglutination test from Oxoid (see Appendix 11).

**Antimicrobial susceptibility**

Antimicrobials that are used to treat *E. coli* urinary and other infections include those with activity against Gram negative organisms such as sulphonamides, trimethoprim, cotrimoxazole, nalidixic acid, nitrofurantoin, tetracycline, ampicillin, amoxycillin, cephalosporins, and aminoglycosides. Plasmid-mediated antibiotic resistance, however, is common. In the treatment of *E. coli* diarrhoea, the use of antibiotics is in general only of minor importance. Rehydration of the patient is always the most important measure taken.

**7.18.15 *Shigella* species**

Based on antigenic structure and biochemical reactions, *Shigella* organisms are divided into four subgroups corresponding to the following species:

**Subgroup A: *Shigella dysenteriae***

Contains 12 distinct serotypes  
Serotype 1 was formerly called *S. shiga*  
Serotype 2 was formerly called *S. schmitzii*

**Subgroup B: *Shigella flexneri***

Contains 6 related serotypes and 4 serotypes divided into subserotypes.

**Subgroup C: *Shigella boydii***

Contains 18 distinct serotypes

**Subgroup D: *Shigella sonnei***

Contains one serotype

**Chart 7.10 Biochemical reactions of some enterobacteria and other enteric organisms**

Species	Urea	VP	ONPG	Lact	Man	Glu	Suc	Ox	Cit	KIA Medium						
										Mot	Ind	LDC	Slope	Butt	H <sub>2</sub> S	Gas
<i>Escherichia coli</i>	–	–	+	+	+	+	d	–	–	+ <sup>5</sup>	+ <sup>2</sup>	+	Y <sup>6</sup>	Y	–	+ <sup>2</sup>
<i>Shigella</i> species	–	–	– <sup>7</sup>	–	d	+	– <sup>1</sup>	–	–	–	d	–	R	Y	–	– <sup>3</sup>
<i>Salmonella</i> Typhi	–	–	–	–	+	+	–	–	–	+	–	+	R	Y	+ Weak	–
<i>Salmonella</i> Paratyphi A	–	–	–	–	+	+	–	–	–	+	–	–	R	Y	–	+
Most other salmonellae	–	–	–	–	+	+	–	–	+	+	–	+	R	Y	+ <sup>2</sup>	d
<i>Citrobacter freundii</i>	d	–	+	+ Late	+	+	d	–	+	+	– <sup>3</sup>	–	R or Y	Y	d	+
<i>Klebsiella p. pneumoniae</i>	+ slow	+	+	+	+	+	+	–	+	–	– <sup>3</sup>	+	Y	Y	–	+
<i>Enterobacter</i> species	–	+	+	+	+	+	d	–	+ <sup>2</sup>	+	–	d	Y	Y	–	+
<i>Serratia marcescens</i>	d	+	+	d	+	+	+	–	+	+	–	+	R or Y	Y	–	d
<i>Proteus vulgaris</i>	+	–	–	–	–	+	+	–	d	+	+	–	R	Y	+	d
<i>Proteus mirabilis</i>	+	d	–	–	–	+	d	–	+ <sup>2</sup>	+	–	–	R	Y	+	+
<i>Morganella morganii</i>	+	–	–	–	–	+	–	–	–	+ <sup>5</sup>	+	–	R	Y	–	d
<i>Providencia</i> species	d	–	–	–	d	+	d	–	+	+	+	–	R	Y	–	d
<i>Yersinia enterocolitica</i> <sup>4</sup>	+ slow	–	+	–	+	+	+	–	–	+	d	–	R	Y	–	–
<i>Vibrio cholerae</i>	–	d	+	– 24h	+	+	+	+	d	+	+	+	R	Y	–	–
<i>Vibrio parahaemolyticus</i>	– <sup>3</sup>	–	+	–	+	+	–	+	d	+	+	+	R	Y	–	–

**Key:** LDC = Lysine decarboxylase, VP = Voges-Proskauer, ONPG = beta-galactosidase, Lact = Lactose, Man = Mannitol (mannite), Glu = Glucose, Suc = Sucrose, Ox = Oxidase test, Cit = Citrate test, Mot = Motility, Ind = Indole test, Urea = Urease, H<sub>2</sub>S = Hydrogen sulphide (blackening), R = Red-pink (alkaline reaction), Y = Yellow (acid reaction), d = different strains give different results.

**Notes**

- S. sonnei* ferments sucrose slowly.
- A minority of strains give a negative result.
- A minority of strains give a positive result.
- Tests should be incubated at 20–28°C.
- A few strains are non-motile.
- A few strains give reactions similar to *Shigella* species.
- S. sonnei* is ONPG positive.

**Testing for biochemical reactions included in this Chart**

An inexpensive and simple way of performing biochemical tests is to use Rosco Diagnostic tablets as described in subunit 7.5.

**Note:** Although DNA hybridization studies have shown *Shigella* species and *E. coli* to be genetically identical, *Shigella* and *E. coli* continue to be described and identified as separate species.

### Pathogenicity

*Shigella* species cause bacillary dysentery, or shigellosis, with *S. dysenteriae* serotype 1 (Sd 1), also known as Shiga bacillus, being the most virulent. It has been estimated that annually there are 164.7 million episodes of shigellosis throughout the world of which 163.2 million occur in developing countries with 1.1 million deaths (61% involving children under 5 years).

In developing countries, most infections are due to *S. dysenteriae* serotype 1 (Sd1) and *S. flexneri*. *S. dysenteriae* 1 causes major epidemics of bacillary dysentery with high loss of life among young children (over 6 months).

### Transmission of shigellae and clinical features

Shigellae infect only humans. Transmission is mainly by the faecal-oral route with poor sanitation, unhygienic conditions, and overcrowding, facilitating the rapid spread of infection. Only a few organisms are required to cause disease. Houseflies help to transfer shigellae from faeces to food. The organisms are rapidly killed by drying.

*S. dysenteriae* 1 causes inflammation and ulceration of the intestinal tract with severe dysentery, marked dehydration and protein loss, abdominal cramps, rectal pain, toxæmia, and high fever. Death can occur from circulatory collapse or kidney failure. Enterotoxin is produced but the virulence of *S. dysenteriae* 1 is thought to be due more to its invasiveness. The total white blood cell count is raised with neutrophilia.

## LABORATORY FEATURES

**Specimens:** A fresh faecal specimen is required to isolate *Shigella* species. When there is likely to be a delay in the specimen reaching the laboratory a suitable transport medium must be used to ensure viability of the organisms (see subunit 7.11).

In the early stages of shigellosis, faecal specimens may be watery and contain little blood, mucus, and pus cells. In the later stages, the specimen may consist entirely of pus and blood mixed with mucus. Specimens have an alkaline pH unlike those from patients with amoebic dysentery which have an acid pH.

### Morphology

Shigellae are Gram negative, non-sporing, and non-capsulate rods. Unlike salmonellae and many other enterobacteria, shigellae are non-motile.

### Culture

Shigellae are aerobes and facultative anaerobes. They grow between 10–45 °C with an optimum temperature of 37 °C. Specimens must be cultured with the minimum of delay. A selective medium is required to isolate *Shigella* species from faeces.

**XLD agar:** Shigellae produce red-pink colonies, 2–4 mm in diameter, without black centres as shown in colour Plate 12.

**DCA and MacConkey agar:** Shigellae produce non-lactose fermenting pale coloured 1–2 mm diameter colonies. On prolonged incubation, *S. sonnei* forms pink colonies.

### Salmonella-Shigella (SS) agar

Despite its name, this medium is not suitable for isolating shigellae as it is inhibitory to most strains.

**Note:** Preparation of each culture medium is described in Appendix 1.

### Biochemical tests

Shigellae can be presumptively identified biochemically using KIA (Kligler iron agar) medium and individual biochemical tests (e.g. Rosco identification tablet tests) or by using commercially produced enterobacteria identification systems.

**KIA**, see No. 45: This medium is used to help identify shigellae following isolation on a primary selective medium. Shigellae produce a pink-red (alkaline) slope and yellow (acid) butt, indicating fermentation of glucose but not lactose (see colour Plate 13).

### Reactions of shigellae

- Lactose negative (*S. sonnei* is a late lactose and sucrose fermenter)
- H<sub>2</sub>S negative
- Urease negative
- Oxidase negative
- Citrate negative
- Lysine decarboxylase (LDC) negative
- Ornithine decarboxylase (ODC) negative except *S. sonnei* which is ODC positive
- Beta-galactosidase (ONPG) negative. *S. sonnei* and up to 15% of Sd 1 strains and minority of *S. boydii* strains are ONPG positive.

**Note:** Other biochemical reactions of shigellae are summarized in Chart 7.10 in subunit 7.18.15.

**Additional tests to identify *S. dysenteriae* 1 (Sd 1)**

- Sd 1 is mannitol negative (also minority of *S. flexneri* serotypes).
- Sd 1 is catalase negative (other shigellae are catalase positive).

**Biochemical reactions which help to differentiate shigellae**

Species	Man	Cat	Ind	LDC	ODC
<i>S. dysenteriae</i>					
1 (Sd 1)	–	–	–	–	–
2	–	+	+	–	–
3–12	–	+	d	–	–
<i>S. flexneri</i>					
1–5	+	+	d	–	–
6	+*	+	–	–	–
<i>S. sonnei</i>	+	+	–	–	+
<i>S. boydii</i>					
1–18	+	+	d	–	–

Man = Mannitol, Cat = Catalase, Ind = Indole, LDC = Lysine decarboxylase, ODC = Ornithine decarboxylase.

**Notes** \*Most strains positive. d Different strains give different reactions.

**Serogrouping**

In microbiology reference laboratories, shigellae are serogrouped by their O antigens (see beginning of subunit 7.18.14) using polyvalent group antisera and when indicated, monospecific (monovalent) antiserum e.g. monovalent *S. dysenteriae* 1 antiserum is required to identify Sd 1.

**Availability of *Shigella* agglutinating antisera**

The following range of monovalent and polyvalent *Shigella* agglutinating antisera are available from Bio-Rad Laboratories (see Appendix 11):

- Code 57161 Monovalent *S. dysenteriae* 1 (2 ml)
- Code 57182 Polyvalent *S. dysenteriae* A1+A2 (2 × 2 ml)
- Code 57151 Polyvalent *S. flexneri* (2 ml)
- Code 57171 Polyvalent *S. sonnei* (2 ml)
- Code 57183 Polyvalent *S. boydii* C1, C2, C3 (3 × 2 ml)

**Non-agglutinating *Shigella***

Some *Shigella* strains (mostly *S. dysenteriae* and *S. sonnei*) possess surface (K) antigens that can 'hide' the O antigens being tested and so prevent agglutination. If, however, a saline suspension of the organism is heated in a container of boiling water for 20 minutes, the surface antigens are inactivated and the organism can be serotyped. Allow the suspension to cool, centrifuge, and test a fresh saline suspension of the sedimented organisms.

**Antimicrobial susceptibility**

Usually only patients with severe shigellosis require antimicrobial therapy. Drug-resistant *Shigella* strains

are becoming widespread. Sd 1 epidemics caused by multi-drug resistant strains are being increasingly reported from developing countries. Resistance is common to ampicillin, cotrimoxazole and more recently nalidixic acid. Resistance of Sd 1 develops rapidly and may even develop during the course of an epidemic.

**FURTHER INFORMATION**

**WHO/CDC/USAID publication** *Manual for the laboratory identification and antimicrobial susceptibility testing of bacterial pathogens of public health importance in the developing world*, 2003 E-mail: cdsdoc@who.int.

**7.18.16 Salmonellae****Classification of salmonellae**

Formerly classified as separate species, DNA hybridization studies have now shown that all pathogenic salmonellae belong to a single species, *Salmonella enterica* which is subdivided into 7 subspecies (subsp.). *S. enterica* subsp. *enterica* has over 2000 serovars which can cause disease in humans. For convenience the serovars (first letter in capitals) are written in an abbreviated form, e.g. the accepted abbreviation for *S. enterica* subsp. *enterica* serovar Typhi is *S. Typhi* (italics is not used for the serovar). This DNA-based classification is used in this publication.

**Pathogenicity**

The following diseases are caused by *Salmonella*:

- **Enteric fever** (typhoid and paratyphoid) with bacteraemia caused by *S. Typhi* (most serious form) and *S. Paratyphi* A, B, C. These salmonellae are usually found only in humans, being excreted in the faeces and urine of infected patients and carriers. Infection is by ingesting the organisms in contaminated food or water or from contaminated hands (*S. Typhi* is mainly water-borne, *S. Paratyphi* is mainly food-borne).

**Enteric fever**

Infection caused by *S. Typhi* is a major public health problem in most developing countries with deaths from typhoid fever increasing in some areas with the emergence of *S. Typhi* strains resistance to previously used antimicrobials. In endemic areas, typhoid fever occurs most frequently in children and young adults (3–19y). The importance and use of improved typhoid vaccine have been reviewed in a WHO document *Diagnosis, treatment and prevention of typhoid fever* (see Further information). Symptoms of enteric fever include persistent high fever with low pulse rate, severe headache, toxemia, enlargement of the spleen, nausea, and apathy or mental confusion. The organisms multiply in reticuloendothelial cells. Invasion of the intestine causes inflammation and ulceration, epistaxis, intestinal haemorrhage and perforation, toxemia and renal failure may

occur in untreated late typhoid (often fatal). A rash (rose spots) on the trunk may be seen on light coloured skin. In uncomplicated typhoid, the total white cell count is normal or low with a relative lymphocytosis. There may also be anaemia. A sudden increase in white cell count may occur with intestinal perforation.

In schistosomiasis endemic areas there is a high incidence of chronic *S. Typhi* and *S. Paratyphi A* infections and carriers. The salmonellae colonize adult schistosome flukes (protected from antibiotics). An immune complex disorder of the kidneys can occur in those with urinary schistosomiasis (nephrotyphoid), characterized by fever, oedema, marked albuminuria and haematuria.

Infection with *S. Typhi* can also cause osteomyelitis and typhoid arthritis particularly in those with sickle cell disease and thalassaemia.

Disease caused by *S. Paratyphi A* and *B* is generally milder than typhoid. There is usually diarrhoea and vomiting and the entire intestinal tract may be inflamed, especially in *B* infections. *S. Paratyphi C* has a limited distribution (common in Guyana and eastern Europe). It causes mainly bacteraemia and occasionally abscesses, arthritis, and inflammation of the gall bladder.

- **Diarrhoeal disease (enterocolitis):** This can be caused by many *Salmonella* serovars. In developing countries, *S. Typhimurium* and *S. Enteritidis* are common causes.

#### **Salmonella enterocolitis**

Infection is by ingesting salmonellae, in food that has become contaminated from animal or human intestinal sources, directly or indirectly. Common sources of infection are poultry, meat and meat products, eggs and egg products. Diarrhoea, vomiting, fever, and abdominal pain occur 12–36 h after eating infected food. In acute infections, blood and mucus are present in faecal specimens. Infants, the elderly, persons already in poor health, those with ulcerative colitis, malignancy, and immunosuppressed persons are at greater risk of developing serious disease.

Food-poisoning *Salmonella* strains can also cause bacteraemia, inflammation of the gall bladder, osteitis especially in children with sickle cell disease, and occasionally abscesses.

- **Bacteraemia:** Non-typhi salmonellae (NTS), particularly *S. Typhimurium* and *S. Enteritidis* are common causes of bacteraemia and septicaemia in young children in developing countries. In Africa and elsewhere, NTS bacteraemia is also common in those co-infected with HIV. Others at high risk include those already in poor health, those with malignancy, sickle cell disease, bartonellosis, and chronic schistosomiasis. *S. Typhimurium* is also reported as causing neonatal meningitis.

## LABORATORY FEATURES

### *Specimens:*

#### ENTERIC FEVER

For the diagnosis of enteric fever, specimens include blood, faeces, and urine for culture.

**Blood:** Organisms can usually be detected in 75–90% of patients during the first ten days of infection, and in about 30% of patients during the third week.

In chronic salmonellosis, it has been reported that *S. Typhi* can be more rapidly and successfully isolated from bone marrow than from blood, especially if the patient has been treated with antibiotics.

**Faeces:** Organisms can usually be isolated from 40–50% of patients during the second week of infection and from about 80% of patients during the third week. Faecal culture is useful for detecting *S. Typhi* carriers.

**Urine:** Organisms can usually be isolated from about 25% of patients after the second week of infection especially from those with urinary schistosomiasis. The bacteria are not excreted continuously and therefore several specimens may need to be cultured before the organisms are isolated.

#### DIARRHOEAL DISEASE

Faeces and blood for culture (during times of fever) are required.

#### BACTERAEMIA

Blood for culture, collected as described in subunit 7.14.

*Note:* When an abscess or arthritis is suspected, pus or joint fluid is required for culture.

#### Morphology

Salmonellae are Gram negative rods. With the exception of *S. Pullorum-gallinarum*, all salmonellae are actively motile. They are non-sporing and with the exception of *S. Typhi*, non-capsulate.

#### Culture

Salmonellae are aerobes and facultative anaerobes. They grow between 15–45 °C with an optimum temperature of 37 °C. A selective medium is required to isolate salmonellae from faecal specimens. Some workers also recommend the use of a selective enrichment broth such as Rappaport-Vassiliadis (RV) broth (when *S. Typhi* is not suspected).

#### *Isolation of S. Typhi from blood*

To isolate enteric fever salmonellae, 10% ox-gall in distilled water is recommended (add 5 ml of whole blood to 50 ml of sterile ox-bile medium). Subculture after overnight incubation onto blood agar.

#### Availability of ox-gall

Ox-gall is available from BD Diagnostics, 500g code D0128-17.

In subunit 7.14 the use of Columbia agar-broth diphasic medium is recommended because this can be used for all salmonellae and other pathogens that cause bacteraemia. Blood cultures are subcultured on to blood agar.

**Blood agar (subculture):** Salmonellae produce grey-white 2–3 mm diameter non-haemolytic colonies, similar in appearance to those of many other enterobacteria. Some strains appear mucoid.

**XLD agar:** Hydrogen sulphide (H<sub>2</sub>S)-producing salmonellae form pink-red colonies 3–5 mm in diameter with black centres as shown in colour Plate 12. Salmonellae that do not produce H<sub>2</sub>S, e.g. most strains of *S. Paratyphi A*, form pink-red colonies without black centres, similar in appearance to shigellae (see colour Plate 11).

**DCA and MacConkey agar:** Salmonellae produce non-lactose fermenting pale coloured colonies which on DCA, have black centres (H<sub>2</sub>S-producing salmonellae).

*Note:* Preparation of each culture medium is described in Appendix 1.

### Biochemical tests

Salmonellae like shigellae can be presumptively identified biochemically using KIA (Kligler iron agar) medium and individual biochemical tests (e.g. Rosco identification tablets) or commercially produced enterobacteria identification systems.

**KIA**, see No. 45: This medium is used to help identify salmonellae following isolation on a primary selective medium. Salmonellae produce:

- pink-red (alkaline) slope and yellow (acid) butt, indicating fermentation of glucose but not lactose.
- cracks in the medium if serotype produces gas from glucose fermentation (*S. Typhi* does not produce gas).
- blackening in the medium due to H<sub>2</sub>S unless serotype does not produce H<sub>2</sub>S, e.g. *S. Paratyphi A*. Only a small amount of blackening is seen with *S. Typhi*.

*Note:* KIA reactions of salmonellae are shown in colour Plate 13 and summarized in Chart 7.8 in subunit 7.11.

### Reactions of salmonellae (most serotypes)

- Urease and indole negative
- Lactose negative
- Gas produced from glucose fermentation (*S. Typhi* does not produce gas)

- Citrate positive (*S. Typhi* and *S. Paratyphi A* are citrate negative)
- Lysine decarboxylase (LDC) positive (*S. Paratyphi A* is LDC negative)
- *Beta*-galactosidase (ONPG) negative

*Note:* Other biochemical reactions of salmonellae are summarized in Chart 7.10 in subunit 7.18.15.

### *S. Typhi*

This can be biochemically differentiated from other salmonellae by being citrate negative, not producing gas and forming only small amounts of H<sub>2</sub>S (see colour Plate 13). Isolates of *S. Typhi* can be identified serologically (see following text).

### Antigenic structure and grouping of some salmonellae according to the Kauffmann-White classification system

Group, Serogroup Serotype	O Antigens	H antigens	
		Phase 1	Phase 2
<b>Group A, serogroup 2</b> <i>S. Paratyphi A</i>	1,2,12	a	–
<b>Group B, serogroup 4</b> <i>S. Paratyphi B</i>	1,4,5,12	b	1,2
<i>S. Derby</i>	1,4,5,12	f,g	(1,2)*
<i>S. Typhimurium</i>	1,4,5,12	i	1,2
<i>S. Heidelberg</i>	(1)*,4,5,(12)*	r	1,2
<b>Group C, serogroup 7</b> <i>S. Cholerae-suis</i>	6,7	c	1,5
<i>S. Paratyphi C</i>	6,7,(Vi)*	c	1,5
<i>S. Oranienburg</i>	6,7	m,t	–
<i>S. Garoli</i>	6,7	i	1,6
<i>S. Thompson</i>	6,7	k	1,5
<i>S. Bareilly</i>	6,7	y	1,5
<b>Group D, serogroup 9</b> <i>S. Typhi</i>	9,12,(Vi)*	d	–
<i>S. Enteritidis</i>	1,9,12	g,m	–
<i>S. Pullorum-Gallinarum</i>	1,9,12	–	–
		(non-motile)	
<b>Group E<sub>1</sub>, serogroup 3,10</b> <i>S. Weltevreden</i>	3,10	r	Z <sub>6</sub>
<i>S. Anatum</i>	3,10	e,h	1,6
<b>Group G, serogroup 13,22</b> <i>S. Poona</i>	13,22	z	1,6
<i>S. Worthington</i>	1,13,23	z	1,w
<i>S. Cubana</i>	1,13,23	Z <sub>29</sub>	–

\*Brackets indicate that the antigen may be present or absent.

*Note:* The O antigen in bold type is common to all members of the group.

Absorbed O antisera are available for each serogroup, e.g. Salmonella O factor is available for serogroup 2, factor 4 for serogroup 4, etc.

### Serotyping

Based on their O and H antigen composition, more than 2300 *Salmonella* serovars are described in the Kauffmann-White scheme. Salmonellae are placed



in groups by their O antigens (A, B, C, etc) and subdivided by their H (phase 1 and 2) antigens. The grouping and antigenic composition of some salmonellae are shown in the previous table. Polyclonal antisera containing antibodies to the major groups can be used to identify an isolate biochemically suspected of being *Salmonella*. Full serotyping (for epidemiological purposes) requires the use of polyvalent and monovalent O and H antisera and is usually carried out in a specialist Public Health Laboratory.

### Diagnosing typhoid fever serologically

Detection of a specific antibody response with typical clinical symptoms is suggestive of enteric fever. To make a definitive diagnosis, culture is required. Serological tests currently in use to assist in the diagnosis of enteric fever include:

- Widal test
- Ig M antibody immunoassays

*Note:* Molecular tests to diagnose typhoid fever such as PCR have been developed but are expensive and not suitable for use in district laboratories.

### Widal test

The diagnostic value of the Widal test remains controversial. Most agree that the test is not sufficiently sensitive or specific to be clinically useful when only a single acute-phase serum sample is tested (common practice). The Widal test measures agglutinating antibody levels against O (somatic) and H (flagellar) antibodies. In acute typhoid fever, O agglutinins can usually be detected 6–8 days after the onset of fever and H agglutinins after 10–12 days.

**Investigating typhoid.** The patient's serum is tested for O and H antibodies (agglutinins) against the following antigen suspensions (usually stained suspensions):

- S. Typhi* O antigen suspension, 9, 12
- S. Typhi* H antigen suspension, d

**Testing for paratyphoid, A, B, or C:** The following antigen suspensions are required:

- *S. Paratyphi* A O antigen suspension, 1, 2, 12
- *S. Paratyphi* A H antigen suspension, a
- *S. Paratyphi* B O antigen suspension, 1, 4, 5, 12
- *S. Paratyphi* B H antigen suspension, b, phase 1
- *S. Paratyphi* C O antigen suspension, 6, 7
- *S. Paratyphi* C H antigen suspension, c, phase 1

*Salmonella* antigen suspensions can be used as slide and tube techniques, with manufacturers providing details for both slide (screen) and tube tests. Before use, the antigen suspensions must be allowed to warm to room temperature and be well-mixed.

In endemic areas the Widal test produces many false positive and false negative test results. False positive results occur because *S. Typhi* shares O and H antigens with other *Salmonella* serovars and cross-reactions also occur with other enterobacteriaceae. Causes of raised O and H agglutinins other than typhoid fever include previous *Salmonella* infections, chronic salmonellosis associated with schistosomal infection and vaccination with TAB or typhoid vaccine. False positive Widal test results are also known to occur in typhus, acute falciparum malaria (particularly in children), chronic liver disease associated with raised globulin levels and disorders such as rheumatoid arthritis, myelomatosis and nephrotic syndrome. False negative Widal tests may be due to antibody responses being blocked by early antimicrobial treatment or following a typhoid relapse. Severe hypoproteinaemia may also prevent a rise in O and H antibody titres.

When, as recommended, paired sera are tested (2nd sample taken 7–10 days after the first sample), usually only a two or three-fold rise in one or both agglutinins occurs. A diagnostic four-fold rise rarely occurs, possibly due to the fact that titres are already significantly raised when a patient's serum is first tested. A knowledge of local normal O and H agglutinin titres is essential in the interpretation of Widal test results. The antibody levels found in a healthy population however, may vary from time to time and in different areas, making it difficult to establish a cut off level of baseline antibody in a defined area and community. In low typhoid endemic areas, weak and delayed O and H antibody responses limit the usefulness of the Widal test. Variations also exist between laboratories in the performance and reading of Widal tests which compromise further the reliability of the test.

### IgM antibody assays to diagnose typhoid fever

These assays detect IgM antibodies to *S. Typhi* which develop early in acute typhoid. They suggest current infection, are more sensitive and specific than the Widal test, and can be performed more rapidly. In the absence of culture facilities, IgM antibody tests are more useful in helping to diagnose typhoid in endemic areas particularly after 7 days following the onset of fever. Commercially available IgM antibody tests include *Enterocheck-WB*, *TYPHIrapid* and *IDL Tubex*,

**Enterocheck-WB:** This is an immunochromatographic test in cassette form which takes 30 minutes to perform (most positive results develop within 15

minutes). In diagnosing typhoid, the sensitivity of *Enterocheck-WB* is reported as 79.3% and specificity as 90.2%. A false negative may occur due to IgG competing with IgM for binding sites. Rheumatoid factor may cause a false positive result.

**Availability:** *Enterocheck-WB* is manufactured and marketed by Zephyr Biomedicals (Tulip Group). See Appendix 11 for contact details.

***TYPHrapid*:** This is an individually packaged immunochromatographic strip test performed in a microtitration plate. It is shown in Fig. 7.29. The test takes 10 minutes to perform. *TYPHrapid* detects an *S. Typhi* specific kD outer membrane protein (OMP). It is an extension of *Typhidot* (IgG and IgM dot immunoassay). It was developed to avoid the need for cold chain storage during transit and to provide a more rapid and simpler test to perform at lower cost. In diagnosing typhoid, *TYPHrapid* is reported as having a sensitivity of 85.9% and specificity of 96.7%.

**Availability:** *TYPHrapid* is manufactured and marketed by Malaysian Bio-Diagnostics Research Sdn Bhd. See Appendix 11 for contact details.

***IDL Tubex*:** This is a semi-quantitative colour reaction competitive agglutination test performed in a tube. It detects IgM antibodies to O9 antigen (found in *S. Typhi* and other subgroup D salmonellae). The test uses magnetic particles and a magnetic-embedded stand is provided to read the test results. The test takes about 2 minutes to perform. A false positive reaction can occur with recent *S. Enteritidis* infection. *IDL Tubex* is reported in field evaluations as having a similar sensitivity and specificity to *Typhidot*. It is however a more expensive test.

**Availability:** *IDL Tubex* is manufactured and marketed by IDL Biotech. See Appendix 11 for contact details.

### Antimicrobial susceptibility

Antimicrobials with activity against *S. Typhi* include chloramphenicol, co-trimoxazole, and ampicillin. Chloramphenicol resistant strains, however, have been reported from developing countries and in recent years major typhoid epidemics caused by strains showing resistance to several antibiotics have occurred in Latin America, Mexico, the Middle East and Southeast Asia.

*S. Typhimurium* multi-drug resistance is causing a major public health problem in several developing countries and other parts of the world where the incidence of salmonellosis (transmitted from animals to humans) has increased greatly.

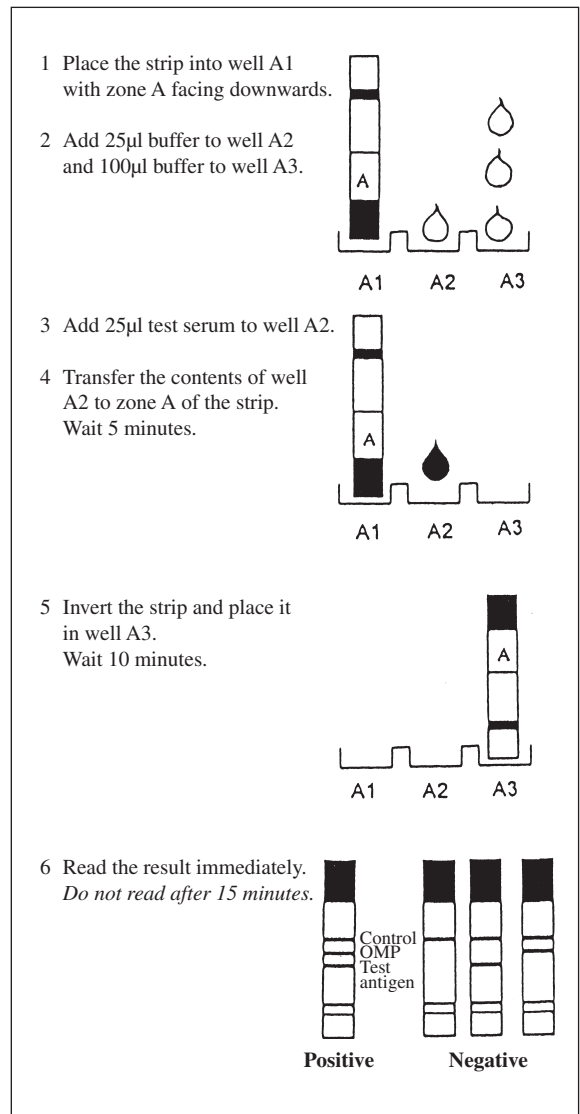

Fig. 7.29 *TYPHrapid* test to detect IgM antibodies. A positive test is shown by the presence of three pink lines; Control line, OMP (outer membrane protein), and 50 kD test antigen.

Courtesy Malaysian Bio-Diagnostics Research.

### FURTHER INFORMATION

**Sonja J et al.** Evaluation of rapid diagnostic tests for typhoid fever. *Journal Clinical Microbiology*, May 42(5), pp. 1885–1889, 2004.

**World Health Organization.** Background document: The diagnosis, treatment and prevention of typhoid fever. WHO/V&B/03.07, 2003.

Can be downloaded from WHO website [www.who.int](http://www.who.int) (use Search facility to locate the document).

### *Citrobacter* species

*Citrobacter* species are Gram negative motile rods. They are opportunistic pathogens and are occasionally isolated from urine, blood, pus, and other specimens. *C. freundii* is the species most frequently isolated.

The biochemical features of *C. freundii* are shown in Chart 7.10 in subunit 7.18.4. Because *Citrobacter* species can be late or non-lactose fermenters, they require differentiation from salmonellae. Many strains of *C. freundii* ferment sucrose whereas *Salmonella* serovars are non-sucrose fermenters.

## 7.18.17 Klebsiellae

### Pathogenicity

*Klebsiella pneumoniae* causes chest infections and occasionally severe bronchopneumonia with lung abscesses. Infections are often opportunistic, occurring in those with existing chest disease or diabetes mellitus, or in malnourished persons.

*Klebsiella aerogenes* is associated with hospital-acquired infections of wounds and of the urinary tract. It is also found in the respiratory tract where it may cause infection, particularly in immunocompromised patients.

*Note:* A separate less common species, *Klebsiella oxytoca* is also associated with hospital-acquired infections.

*Klebsiella rhinoscleromatis* causes rhinoscleroma (granulomatous disease) of the nose and pharynx. Chronic inflammatory growths can lead to deformity of the nose or distortion of the respiratory passages. The disease is found mainly in Central and South America, Java, Sumatra, Morocco, Bengal and parts of eastern Europe.

*Klebsiella ozaenae* is a rare respiratory pathogen, causing chronic destruction of mucous membranes.

### LABORATORY FEATURES

*Specimens:* Depending on the site of infection, specimens include urine, pus, sputum and infected tissue.

### Morphology

Klebsiellae are Gram negative, non-motile, usually capsulated rods.

### Culture

Klebsiellae are aerobes and facultative anaerobes.

**Blood agar:** Klebsiellae produce large grey-white usually mucoid colonies.

**MacConkey agar and CLED medium:** Most klebsiellae are lactose-fermenting, producing mucoid pink colonies on MacConkey agar and yellow mucoid colonies on CLED medium (see colour Plates 18 and 19). *K. rhinoscleromatis* is non-lactose fermenting.

*Note:* Preparation of MacConkey agar and CLED medium is described in Appendix 1.

### Biochemical tests

Klebsiellae are indole negative (*K. oxytoca* is indole positive), ornithine decarboxylase negative and do not produce  $H_2S$ . Tests which can be used to differentiate *Klebsiella* organisms are summarized in the following table:

#### Tests which differentiate *Klebsiella* organisms

	VP	Lact	Ure	Cit	Mal	LDC
<i>K. pneumoniae</i>	–	+	+	+	+	+
<i>K. aerogenes</i>	+	+	+	+	+	+
<i>K. ozaenae</i>	–	+	–	+	–	+
		–		–		–
<i>K. rhinoscleromatis</i>	–	–	–	–	+	–

**Key:** VP = Voges-Proskauer, Lact = Lactose fermentation, Ure = Urease, Cit = Citrate, Mal = Malonate utilization, LDC = Lysine decarboxylase.

### Antimicrobial susceptibility

Klebsiellae often produce *beta*-lactamases and are resistant to ampicillin. Cephalosporins and aminoglycosides are used to treat *Klebsiella* infections. Some *Klebsiella* strains show multiple drug resistance.

### *Enterobacter* species

*Enterobacter* organisms can be found in the intestinal tract of humans and animals, and in soil, sewage, water, and dairy products. They are opportunistic pathogens, associated with urinary infections, wound infections, and septicaemia, especially in persons already in poor health.

*Enterobacter* species are Gram negative motile rods. On blood agar, they produce large colonies that may resemble those produced by klebsiellae but not so mucoid. They are,

however, motile whereas klebsiellae are non-motile. The features that distinguish *Enterobacter* species from other enterobacteria are listed in Chart 7.10 in subunit 7.18.15.

### *Serratia* species

*Serratia* species are found mostly in soil and water. They have been reported as causing pulmonary and urinary infections and also cross-infections in hospitals. *S. marcescens* is the main species of medical importance.

*Serratia* species are Gram negative motile rods. *S. marcescens* grows well on blood agar and MacConkey agar. It is non-lactose fermenting. Some strains produce a red pigment in nutrient agar at room temperature. The biochemical reactions of *S. marcescens* are shown in Chart 7.10 in subunit 7.18.15. *Serratia* species are usually resistant to cephalosporins, polymyxins, and occasionally also to aminoglycosides.

## 7.18.18 *Proteus mirabilis*

### Pathogenicity

*P. mirabilis* causes:

- Urinary infections. *Proteus* infected urine has an alkaline reaction.  
*P. mirabilis* is a common cause of urinary infection in the elderly and young males and often following catheterization or cystoscopy. Infections are also associated with the presence of renal stones.
- Abdominal and wound infections, *Proteus* is often a secondary invader of ulcers, pressure sores, burns and damaged tissues.
- Septicaemia and occasionally meningitis and chest infections.

### *P. vulgaris*

This species is occasionally isolated from urine, pus, and other specimens. *P. mirabilis* infections usually respond better to antimicrobial therapy than those caused by *P. vulgaris* and other related organisms.

### LABORATORY FEATURES

*Specimens:* Depending on the site of infection, specimens include urine, pus, sputum.

### Morphology

*P. mirabilis* and *P. vulgaris* are actively motile, non-capsulate, Gram negative pleomorphic rods. Motility is not as easily observed at 35–37°C as at room temperature (20–28°C).

### Culture

**Blood agar:** When cultured aerobically, most *Proteus* cultures have a characteristic 'fishy' odour.

### Preventing *Proteus* swarming on blood agar

The addition of chemicals, drying of agar plates, use of alcohol treated plates, or increasing the concentration of agar, are often recommended to prevent *Proteus* from swarming. Such methods however can interfere with the growth of pathogens.

When half blood agar plates are used for culturing specimens, a narrow central strip of medium can be cut out (ditching) to prevent the spread of *Proteus* from one specimen to the other. Alternatively, plates with a central divider can be used.

*Note:* A pathogen can often be separated from a *Proteus* contaminated plate by subculturing on MacConkey agar, providing this is not inhibitory to the pathogen. Alternatively, an ether shake technique can be attempted but this is not always successful.

**MacConkey, CLED, XLD media:** *Proteus* produces individual non-lactose fermenting colonies after overnight incubation at 35–37°C (see colour Plates 11, 14, 18). Swarming is prevented on MacConkey agar and XLD agar because these media contain bile salts. Swarming is inhibited on CLED agar because it is electrolyte deficient.

*Note:* Preparation of each culture medium is described in Appendix 1.

### Biochemical tests

*Proteus* species:

- Do not ferment lactose.
- Rapidly hydrolyze urea (within 4 hours), see subunit 7.5.9. This is an important early screening test in differentiating enteric pathogens, e.g. salmonellae and shigellae from *Proteus*.
- Phenylalanine deaminase (PDA), positive.
- Beta-galactosidase (ONPG) negative.
- Indole negative (*P. vulgaris* is indole positive).

Other biochemical reactions of *P. mirabilis* are shown in Chart 7.10 in subunit 7.18.15. Reactions which differentiate *Proteus* species from *Morganella morganii* and *Providencia* species are summarized at the end of this subunit.

### *Proteus* strains OX19, OXK, OX2

Some of the antigens of *Proteus* strains OX19, OXK, and OX2, agglutinate with sera from patients with rickettsial diseases. These reactions form the basis of the Weil-Felix test described in subunit 7.18.35.

### Antimicrobial susceptibility

Antibiotics with activity against *P. mirabilis* include ampicillin, cephalosporins and aminoglycosides. Some strains of *P. mirabilis* are beta-lactamase producing and therefore resistant to ampicillin. *Proteus* species are resistant to polymyxin and nitrofurantoin.

### *Morganella morganii*

*M. morganii* (formerly *Proteus morganii*) can be found in human and animal intestines and in sewage, soil, and water. Occasionally it causes urinary and other infections which are often hospital-acquired. It has also been reported as causing diarrhoea in infants.

*M. morganii* is a Gram negative motile rod. Some strains are non-motile. It produces non-lactose fermenting colonies on MacConkey agar. When cultured on blood agar at 35–37°C, most *M. morganii* strains produce individual colonies not a swarming-type growth.

Like *Proteus* species, *M. morganii* is urease positive but it does not hydrolyze urea as rapidly as *Proteus* strains. The biochemical reactions that differentiate *M. morganii* from *Proteus* and *Providencia* species are shown in the chart at the end of this section. See also Chart 7.10 in subunit 7.18.15.

### *Providencia* species

The normal habitat of *Providencia* species is the same as that for *M. morganii* and *Proteus* species. *Providencia* species have been reported as causing urinary infections (especially in those with urinary disorders), burns, and diarrhoeal disease. Infections are often hospital-acquired, especially those caused by *P. rettgeri*.

*Providencia* species are Gram negative motile rods. They grow on selective enteric media. They are non-lactose fermenters and some strains give reactions similar to shigellae on Kligler iron agar. Unlike shigellae, however, they are motile and utilize citrate.

Other biochemical reactions that differentiate *Providencia* species from other enterobacteria are listed in Chart 7.10 in subunit 7.18.15.

### Biochemical reactions that differentiate *Proteus* species, *M. morganii*, and *Providencia* species

Species	Urea	Cit	Ind	Suc	H <sub>2</sub> S	PDA	GG
<i>Proteus mirabilis</i>	+ 4h	d	–	–	+	+	+
<i>Proteus vulgaris</i>	+ 4h	d	+	+	+	+	d
<i>Morganella morganii</i>	+ 8h	–	+	–	–	+	d
<i>Providencia alcalifaciens</i>	–	+	+	+ Slow	–	+	d
<i>Providencia rettgeri</i>	+ 4h	+	+	+ Slow	–	d	d
<i>Providencia stuartii</i>	–	+	+	+ Slow	–	+	–

**Key:** Urea = Urease test, Cit = Citrate test, Ind = Indole test, Suc = Sucrose fermentation, H<sub>2</sub>S = Hydrogen sulphide production, PDA = Phenylalanine deaminase test, GG = Gas from glucose fermentation, d = different strains give different results.

## 7.18.19 *Vibrio cholerae*

### Pathogenicity

*V. cholerae* causes cholera which WHO estimates is responsible for 120 000 deaths each year and is on the rise worldwide. Two serogroups of *V. cholerae* cause epidemic cholera:

#### ■ *V. cholerae* 01

##### Biotypes

- El Tor (also written eltor) which is responsible for most *V. cholerae* 01 cholera
- Classical, which is confined to India and Bangladesh

##### Serotypes:

- Inaba
- Ogawa

**Note:** The Hikojima serotype is rare. It possesses characteristics of both Inaba and Ogawa serotypes

*V. cholerae* 01 El Tor is the cause of the current 7th cholera pandemic which started in Indonesia in 1961, spread rapidly to Bangladesh, India, Iran, Iraq, and in 1970 to West Africa from where it spread to East, Central and South Africa. In 1991 cholera reached Peru and has now spread throughout South and Central America.

#### ■ *V. cholerae* 0139 (synonym Bengal)

This serogroup is the cause of a cholera epidemic which began in Bengal in 1992 and has now

spread to much of Southeast Asia and the Far East. Cholera due to *V. cholerae* 0139 has been reported from China, Saudi Arabia and eleven countries in South Asia. In Bangladesh and India the incidence of *V. cholerae* 0139 is rising.

*Note:* Several other serogroups of *V. cholerae* cause diarrhoeal disease but not epidemic cholera.

### Cholera

*V. cholerae* 01 and 0139 cause secretory non-inflammatory diarrhoeal disease. The organisms produce a powerful enterotoxin (cholera toxin) which comprises two subunits A and B. The B subunit binds to receptors on the intestinal cell, enabling the A subunit to enter the cells. Inside the cells the A subunit activates the enzyme adenylate cyclase which increases the level of cyclic adenosine monophosphate (cAMP) in the cells. This results in the secretion of large volumes of fluid and electrolytes into the lumen of the intestine and the severe almost continuous watery diarrhoea associated with cholera. Faecal specimens are often referred to as 'rice water' stools.

In acute cholera, the rapid loss of fluid and electrolytes in vomit and stools leads to severe dehydration which if not corrected can be rapidly fatal due to renal failure and hypovolaemic shock. Many *V. cholerae* infections are mild and do not progress to severe cholera. In endemic cholera, young children are more commonly infected than adults.

*V. cholerae* is transmitted by the faecal-oral route when water supplies become faecally contaminated. Transmission can also occur by ingesting contaminated food, e.g. uncooked shellfish and other seafood collected from polluted coastal waters. Marine shellfish and plankton are important reservoirs of *V. cholerae*. Filtering drinking water through four layers of cloth can help to remove plankton-containing cholera organisms.

Cholera epidemics occur particularly in crowded living conditions e.g. refugee camps when water supplies are unsafe and sanitation, food safety and hygiene are inadequate. Risk of cholera epidemics is high following natural and man-made disasters, which result in flooding with faecal contamination of the environment and water supplies and lack of clean drinking water. Because of the short incubation period (2 hours–5 days), mortality rates can be high.

Information on the management of cholera epidemics can be found in the WHO publication *Cholera Outbreak* (see Further information).

### LABORATORY FEATURES

*Specimens:* A faecal specimen is required to test directly for *V. cholerae* antigen (see later text), and to isolate *V. cholerae* in culture. If there is likely to be a delay in the specimen reaching the laboratory (not more than 24 h) a transport medium such as alkaline peptone water should be used (see No. 10). This is an excellent transport and enrichment medium for *V. cholerae* (not suitable for other enteric pathogens). Cary-Blair transport medium should be used when *V. cholerae* and other enteric pathogens are to be cultured.

### Morphology

*V. cholerae* is a Gram negative motile usually curved rod (vibro), measuring  $3\text{--}4 \times 0.5 \mu\text{m}$  with a single flagellum at one end. The typical morphology of vibrios is shown in colour Plate 7. In smears made from solid cultures, the vibrios may appear less curved. The use of dilute carbon fuchsin (1 in 10) is recommended as a counterstain in the Gram technique when staining *Vibrio* species. *V. cholerae* 0139, unlike *V. cholerae* 01, is capsulated.

### Motility

*V. cholerae* is highly motile with a distinctive rapid to-and-fro movement which has been likened to swarming gnats. Vibrio motility is best seen using dark-field microscopy, but the vibrios can also be seen using transmitted light microscopy (see subunit 7.3).

### Culture

*V. cholerae* is an aerobe and facultative anaerobe. It can grow over a wide temperature range of 16–40 °C with an optimum of 37 °C. It grows best at an alkaline pH (pH 8.2). *V. cholerae* is non-halophilic, i.e. it does not grow, like most other *Vibrio* species in media containing 6–10% sodium chloride (see Table at end of subunit).

**Alkaline peptone water:** *V. cholerae* grows rapidly, producing growth (turbidity) on and just below the surface of the medium, usually within 4–6 hours. It is an enrichment medium and its alkalinity suppresses the growth of intestinal commensals. To confirm that the organisms are vibrios, examine a wet preparation and a Gram stained smear.

**Thiosulphate-citrate bile salt sucrose (TCBS) agar:** This is an excellent selective medium for the primary isolation of *V. cholerae*. Prior enrichment in alkaline peptone water is recommended unless the specimen is likely to contain many vibrios.

On TCBS agar, *V. cholerae* 01 and 0139 produce 2–3 mm in diameter sucrose-fermenting yellow colonies after overnight incubation at 35–37 °C, (see colour Plate 8). Similar colonies are also produced by other *V. cholerae* serogroups and most strains of *Vibrio fluvialis* (described at the end of this subunit). Occasionally enterococci grow on TCBS agar (very small yellow colonies as shown in colour

Plate 9) and also *Aeromonas* (see end of subunit).

**Comparison of Monsur's medium and TCBS medium**

Monsur's modified medium (peptone substituted for trypticase, and gelatin omitted) can also be used as a selective medium for the primary isolation of *V. cholerae*. When compared, however, with TCBS medium, the colonies produced on Monsur's medium are not as easy to differentiate. Monsur's medium is also more difficult to prepare than TCBS. The amount of potassium tellurite added to the medium must be exact otherwise the growth of *V. cholerae* will be suppressed.

**KIA:** *V. cholerae* produces a red-pink slope and yellow butt. Gas is not formed and H<sub>2</sub>S is not produced.

**Media containing bile salts:** Most strains of *V. cholerae* are able to grow on MacConkey agar, producing small non-lactose fermenting colonies after overnight incubation. With prolonged incubation, lactose may be fermented. *V. cholerae* grows poorly or not at all on DCA and XLD agar.

**Blood agar:** *V. cholerae* 01 and 0139 grow on blood agar, (subcultured from alkaline peptone water), often producing *beta*-haemolytic colonies.

**Note:** Preparation of each culture medium is described in Appendix 1.

**Biochemical tests**

Subculture colonies resembling *V. cholerae* from TCBS agar to a non-selective medium such as nutrient agar. This is essential before biochemically testing or serotyping sucrose-fermenting (yellow) colonies. Sufficient growth is usually obtained on a nutrient agar slope after 4–6 hours incubation at 35–37°C.

*V. cholerae* 01 and 0139 reactions

- Oxidase positive (see subunit 7.5.8). All *Vibrio* species are strongly oxidase positive.
- Do not ferment L-arabinose. This test is of value in differentiating *V. cholerae* from *V. fluvialis* (both produce yellow colonies on TCBS agar). *V. fluvialis* ferments L-arabinose.

Testing for L-arabinose fermentation can be easily and economically performed using a Rosco L-arabinose identification tablet (code 521-21).

**Note:** Other biochemical reactions are shown in Chart 7.10 in subunit 7.18.15. Tests to differentiate

*V. cholerae* from other *Vibrio* species and *Aeromonas hydrophila* are summarized in the Table at the end of this subunit.

**Tests to differentiate *V. cholerae* 01 biotypes**

In most countries *V. cholerae* 01 cholera is caused by the El Tor biotype. In India and Bangladesh where the Classical biotype also occurs, the Voges-Proskauer (VP) test (e.g. using a Rosco tablet test, code 57711) can be used to differentiate the two biotypes. The El Tor biotype is VP positive and the Classical biotype is VP negative.

When required other tests (haemagglutination and sensitivity to 50 iu polymyxin B) can also be performed in a reference laboratory. El Tor gives a positive agglutination test and is resistant to 50 iu polymyxin B. Classical biotypes give a negative agglutination test and are sensitive to 50 iu polymyxin B.

**Serotyping *V. cholerae* 01 and 0139**

Separate antisera are required to identify *V. cholerae* 01 (Inaba and Ogawa) and *V. cholerae* 0139 (Bengal). Isolates from TCBS cultures require subculturing to nutrient agar before carrying out serotyping.

**Availability of *V. cholerae* antisera**

Several manufacturers supply *V. cholerae* (slide agglutinating) antisera. Information on suppliers can be obtained from the Pasteur Institute (see Appendix 11).

**Note:** It is also recommended that in areas where *V. cholerae* 0139 occurs, microbiology laboratories contact their WHO Regional Office for information on local suppliers of antisera.

**Rapid dipstick test to detect *V. cholerae* 01 and 0139 in faecal specimens**

An easy to perform low cost immunochromatographic dipstick (strip test) has been developed recently by the Institut Pasteur for the rapid detection of *V. cholerae* 01 and 0139 in endemic areas directly from faeces or from a rectal swab that has been first incubated in alkaline peptone water. The dipsticks are packaged individually and can be transported and stored at room temperature (4–25°C). They must be protected from direct sunlight.

*Method using faeces*

- 1 Centrifuge fluid faeces\* at 1500 rpm for 5 minutes.

\*Emulsify formed faeces in physiological saline or distilled water prior to centrifuging.

- 2 Transfer 200 µl (0.2 ml) of supernatant fluid to a small test tube.
- 3 Immediately before use, remove a dipstick from its moisture-proof plastic bag and place it in the tube ensuring the absorbent pad of the dipstick is below the level of the fluid.

- 4 Read the result within 15 minutes.

**Positive test for *V. cholerae* 01:** Two pink-red lines, one in T1 test area, and another in area C (Control line).

**Positive test for *V. cholerae* 0139:** Two pink-red lines, one in T2 test area, and another in area C (Control line).

**Negative test\*:** Pink-red line in area C (Control line) only

\*Note: A negative test result will also occur when the quantity of antigen in the sample is below the sensitivity level of the dipstick (i.e. below  $10^7$  CFU *V. cholerae* 01 or 0139/ml).

#### Method using a rectal swab

- 1 Incubate the swab in alkaline peptone water (No. 10 in Appendix 1) at 37°C for 6 hours.
- 2 Transfer 200 µl (0.2 ml) of alkaline peptone water culture to a small test tube.
- 3 Continue as described in the previous Method. Interpret the results as described previously.

#### Sensitivity and specificity of *V. cholerae* 01 and 0139 dipstick

When compared to culture, the sensitivity of the *V. cholerae* dipstick in cholera endemic areas has been reported as 77–96% and the specificity as 97–99%.

**Availability:** The *V. cholerae* 01 and 0139 dipstick is manufactured and marketed by Span Diagnostics. See Appendix 11 for contact details.

#### Antimicrobial susceptibility

The essential treatment of cholera is fluid and electrolyte replacement. Occasionally short-course antibiotic therapy, e.g. with tetracycline (but resistance is common) or deoxycycline may be indicated to reduce the duration of infection and volume of fluid excreted in those severely dehydrated. *Vibrio cholerae* El Tor is becoming increasingly resistant to some antimicrobials. Most *V. cholerae* 0139 strains are susceptible to tetracycline. Information on the availability and use of vaccines against *V. cholerae* El Tor and *V. cholerae* 0139 can be obtained from the WHO Global Task Force on Cholera Control (E-mail: cholera@who.int).

#### FURTHER INFORMATION

Readers are referred to the WHO publication, *Cholera Outbreak – assessing the outbreak response and improving preparedness*. Global Task Force on Cholera Control, WHO/CDS/CPE/ZFK, 2004.4, 2004. E-mail: cholera@who.int. Can be downloaded from WHO website www.who.int/cholera or write to WHO, 1211 Geneva 27, Switzerland.

#### Other Pathogenic *Vibrio* Species

The following are some of the other vibrios which occasionally cause disease. Depending on species, they can be found in sewage, surface waters, marshes, river estuaries, brackish water, and warm coastal waters. Shellfish and other seafood can become contaminated.

**Non-01 and non-0139 *V. cholerae*:** Occasionally cause outbreaks of diarrhoeal disease with cholera-like symptoms.

- *Vibrio mimicus*: Is associated mainly with enteritis following the ingestion of contaminated shellfish, and ear infections following swimming in infected water.
- *Vibrio fluvialis*: Reported as causing gastroenteritis and cholera-like diarrhoeal disease in India, Bangladesh, the Middle East, Egypt, Tunisia, East Africa, Indonesia and the Philippines.
- *Vibrio parahaemolyticus*: Lives in sea-water and estuaries. Ingestion of contaminated raw fish and shellfish can cause severe acute gastroenteritis. *V. parahaemolyticus* food-poisoning has been reported from the Far East, Southeast Asia (infections have increased in recent years), Pacific islands and parts of Central America.
- *Vibrio alginolyticus*: Mainly an opportunistic pathogen causing wound, ear, and eye infections (it is not an enteropathogen).
- *Vibrio vulnificus*: When ingested, this organism can cause a fatal septicaemia, mainly in patients with liver disease or malignancy. *V. vulnificus* is also associated with infections of wounds usually following injuries at sea or when handling infected marine animals. Wounds may become severely inflamed with necrosis of skin and muscle.

**Specimens:** include faeces for the isolation of vibrios that cause enteritis, and pus and wound swabs for the isolation of *V. alginolyticus* and *V. vulnificus*.

#### Tests used to differentiate *Vibrio* organisms that grow on TCBS agar

- **Sucrose fermentation:** *V. cholerae*, *V. fluvialis* and *V. alginolyticus* (not an enteropathogen) produce yellow sucrose-fermenting colonies on TCBS agar. *V. mimicus*, *V. vulnificus* and *V. parahaemolyticus* produce green-blue non-sucrose fermenting colonies.
- **Growth in sodium chloride free peptone water (need not be alkaline) and peptone water con-**



Features which differentiate *Vibrio* species and *Aeromonas hydrophila*

<i>Vibrio</i> species	TCBS	Ox	Mdw <sup>5</sup>	NaCl g/l		NaCl free	Ara	Aesc
				80	100			
<i>V. cholerae</i> 01 and 0139 <sup>1</sup>	Y	+	–	–	–	+	–	–
Non-01 <i>V. cholerae</i> Non-0139 <i>V. cholerae</i>	Y	+	–	–	–	+	–	–
<i>V. fluvialis</i>	Y	+	–	d	–	d	+	+
<i>V. alginolyticus</i> <sup>2</sup>	Y	+	–	+	+	–	–	2
<i>V. mimicus</i>	G	+	–	–	–	+	–	–
<i>V. vulnificus</i>	G	+	–	–	–	–	–	+
<i>V. parahaemolyticus</i>	G	+	–	+	–	–	d <sup>3</sup>	–
<i>A. hydrophila</i> <sup>4</sup>	Y	+	+	–	–	+	+	+

**Key:** TCBS = Thiosulphate citrate bile salt sucrose agar, Ox = Oxidase test, Mdw = Motility in distilled water (see Note 5), NaCl g/l = Sodium chloride grams per litre in peptone water, NaCl free = Sodium chloride-free peptone water, Ara = L-arabinose fermentation, Aesc = Aesculin hydrolysis.

Y = Yellow (sucrose fermenting) colonies, G = Green-blue (non-sucrose fermenting) colonies, d = different strains give different reactions.

**Notes**

- 1 *V. cholerae* 01 and *V. cholerae* 0139 are identified using specific *V. cholerae* antisera (see previous text).
- 2 *V. alginolyticus* is not an enteropathogen.
- 3 Up to 75% of strains ferment L-arabinose.
- 4 For further information about *Aeromonas* species, see following text.
- 5 Motility in distilled water is a simple way of differentiating *Vibrio* species from *Aeromonas* species which may also grow on TCBS (see following text).

taining 80 g/l (8%) and 100 g/l (10%) sodium chloride: Vibrios that are capable of growth at high salt concentrations, e.g. *V. alginolyticus* and *V. parahaemolyticus* are referred to as halophiles.

- **Fermentation of L-arabinose:** This test helps to differentiate *V. cholerae* which does not ferment L-arabinose from *V. fluvialis* which is L-arabinose-fermenting (both species produce yellow colonies on TCBS).

The reactions of the different *Vibrio* species are summarized in the following table. The reactions of *Aeromonas hydrophila* are also included as this pathogen, although only occasionally isolated, grows on TCBS agar and requires differentiation from *V. cholerae* (see following text).

***Aeromonas* species**

*Aeromonas* species can be found in water and soil. Most are non-pathogenic or of low pathogenicity. *A. hydrophila*,

however, has been reported as causing septicaemia, cellulitis, meningitis, wound infections, and acute diarrhoeal disease resembling cholera.

*Aeromonas* species are Gram negative motile rods. *A. hydrophila* produces small beta-haemolytic colonies on blood agar. It will grow on MacConkey agar and sometimes on TCBS, producing yellow colonies. Like *Vibrio* species, *Aeromonas* species are oxidase positive. *A. hydrophila* unlike *V. cholerae*, hydrolyzes aesculin. Other reactions are shown in the above Table. A useful simple test to differentiate *Aeromonas* species from *Vibrio* species is the ability of *Aeromonas* species to remain motile in distilled water (vibrios are immobilized).

***Distilled water motility test to differentiate Vibrio and Aeromonas***

Mix a loopful of growth from a nutrient agar subculture in a drop of sterile distilled water on one end of a slide. On the other end of the slide, mix another loopful of growth in a drop of peptone water. Cover each preparation with a cover glass. Examine microscopically using the 40× objective.

**Results:** All *Vibrio* species are immobilized in distilled water but remain motile in peptone water. *Aeromonas* species remain motile in distilled water and peptone water.

*Note:* The motility of other Gram negative enterobacteria is not affected by distilled water. *Campylobacter* species, however, are also immobilized in distilled water but these organisms do not grow on TCBS.

## 7.18.20 *Pseudomonas aeruginosa* and related organisms

### Pathogenicity

*P. aeruginosa* can be found in the intestinal tract, water, soil and sewage and is frequently found in moist environments in hospitals, (sinks, cleaning buckets, drains, humidifiers etc). It is able to grow in some eye drops (especially quaternary ammonium compounds), saline and other aqueous solutions. Because of this, many infections with *P. aeruginosa* are opportunistic hospital-acquired, affecting those already in poor health and immunosuppressed. Infections are often difficult to eradicate due to *P. aeruginosa* being resistant to many antimicrobials.

Infections caused by *P. aeruginosa* include:

- Skin infections, especially burn sites, wounds, pressure sores, and ulcers (often as secondary invader). Septicaemia may develop.
- Urinary infections, usually following catheterization or associated with chronic urinary disease.
- Respiratory infections especially in patients with cystic fibrosis or conditions that cause immunosuppression.
- External ear infections (otitis externa) and eye infections often secondary to trauma or surgery.

### LABORATORY FEATURES

*Specimens:* Depending on the site of infection, specimens include pus, urine, sputum, effusions, and blood for culture.

### Morphology

*P. aeruginosa* is a Gram negative, non-sporing motile rod. Some strains are capsulate.

#### Culture

*P. aeruginosa* is an obligatory aerobe. It is usually recognized by the pigments it produces including pyocyanin a blue-green pigment, and pyoverdine (fluorescein) a yellow-green fluorescent pigment. A minority of strains are non-pigment producing. Cultures have a distinctive smell due to the production of

2-aminoacetophenone. *P. aeruginosa* grows over a wide temperature range 6–42 °C with an optimum of 35–37 °C.

**Blood agar:** *P. aeruginosa* produces large, flat, spreading colonies which are often haemolytic and usually (90% of strains) pigment-producing. The pigments diffuse into the medium giving it a dark greenish-blue colour (see colour Plate 47). Some strains produce small colonies or mucoid colonies. When the culture is left at room temperature, pigment colour becomes more intense.

**MacConkey agar and CLED medium:** *P. aeruginosa* produces pale coloured colonies on MacConkey agar and green colonies on CLED medium. Compared with blood agar, pigment production is less marked.

**KIA medium:** A characteristic pink-red slope (often with a metallic appearance), and pink-red butt are produced. No gas is formed and no H<sub>2</sub>S is produced.

### Biochemical reactions

*P. aeruginosa* is oxidase positive (see subunit 7.5.8) and produces acid only from glucose (no gas). These features together with the typical pigments produced by most strains and the distinctive smell of cultures are usually sufficient to identify the organism. Growth at 42 °C differentiates *P. aeruginosa* from the less commonly isolated pseudomonads, *P. putida* and *P. fluorescens* (see following text).

*Note:* When acid is formed from carbohydrate media, pseudomonads do this by oxidation, not by fermentation. For oxidative reactions which help to differentiate *P. aeruginosa* from *P. putida* and *P. fluorescens*, see later text.

### Antimicrobial susceptibility

*P. aeruginosa* is resistant to most of the commonly used antibiotics. Antimicrobials that usually show activity against *Pseudomonas* include aminoglycosides, polymyxin, and some penicillins and cephalosporins.

### *Pseudomonas putida* and *Pseudomonas fluorescens*

*P. putida* and *P. fluorescens* are less commonly isolated opportunistic pseudomonads of low pathogenicity. They are however able to grow at 4 °C and are occasionally found as contaminants of blood stored in blood banks. Severe reactions can occur if such contaminated blood is transfused.

Features which can be used to identify *P. putida* and *P. fluorescens* and differentiate these fluorescent pseudomonads from *P. aeruginosa* are summarized in the following Table.

	Growth at:		Acid from:	
	4°C	42°C	Mannitol	Maltose
<i>P. aeruginosa</i> <sup>2</sup>	–	+	+	–
<i>P. fluorescens</i> <sup>3</sup>	+	– <sup>1</sup>	+	+
<i>P. putida</i> <sup>3</sup>	+ <sup>1</sup>	–	–	–

**Notes**

- 1 Most strains give reaction shown.
- 2 Most strains produce both pyocyanin and fluorescein pigments.
- 3 Only fluorescein pigment is produced.

### ***Burkholderia pseudomallei***

*B. pseudomallei* (formerly *Pseudomonas pseudomallei*) causes melioidosis (pneumoenteritis) in humans and animals. Latent infections may become active some years later due to immunosuppression.

The disease is found mainly in Malaysia, Vietnam, Thailand, Myanmar, Guam, Sri Lanka, northern Australia, and the Philippines, especially in rice-growing areas and often in the wet season. The bacteria enter open wounds but can also be inhaled.

*B. pseudomallei* is a highly infectious pathogen (Hazard Risk Group 3), therefore handle specimens with care. It is a small, motile, Gram negative rod which shows bipolar staining (like safety pins), particularly when stained with methylene blue or Giemsa stain.

The organism may be found in sputum in pulmonary disease, blood in systemic disease, and also in pus from abscesses. In countries where melioidosis is endemic, microbiology laboratories should consult their central Public Health Laboratory regarding the use of selective media and techniques to isolate *B. pseudomallei*.

*B. pseudomallei* is an aerobe. It produces non-haemolytic, small, dry, ringed and striated colonies on blood agar after overnight incubation. The colonies become wrinkled after several days incubation.

On MacConkey agar, *B. pseudomallei* forms acid from lactose. Colonies have a rough and corrugated appearance. The organism does not produce pyocyanin or fluorescein but forms an orange-brown pigment. *B. pseudomallei* cultures give off an ammoniacal smell. A pellicle (skin) is formed on broth cultures.

*B. pseudomallei* is oxidase positive and forms acid (oxidatively) from glucose, lactose, maltose and mannitol. It also grows at 42°C. Cultures should be sent (securely) to a Reference Microbiology Laboratory for serological confirmation.

## 7.18.21 *Campylobacter* species

**Pathogenicity**

*Campylobacter jejuni* and *Campylobacter coli* cause enteritis which may take the form of toxigenic watery diarrhoea or dysentery. The organisms are able to produce enterotoxins and cytotoxins. In developing countries, *C. jejuni* and *C. coli* cause disease mainly in children under 2 years. The organisms are found in the gut of poultry, pigs, sheep, goats, cattle and other animals. The main sources of human infection are poultry, unpasteurized milk and contaminated water (faecal-oral route). Natural immunity develops early in life.

**Arcobacter group of aerotolerant campylobacters:** Recently recognized as causing diarrhoeal disease, this group of campylobacters is referred to as aerotolerant because they grow in the presence of oxygen. They are able to grow at 15°C, 25°C, 36°C but not 42°C. *A. butzleri* has been isolated in patients with AIDS and in children in developing countries.

**LABORATORY FEATURES**

**Specimens:** Fresh diarrhoeal or dysenteric specimens containing blood, pus and mucus (child under 2 y). Specimens that have been refrigerated for up to 24 h can also be used for *Campylobacter* culture because the organisms are resistant to cold temperatures (2–8°C).

**Morphology**

Campylobacters are small delicate, spirally curved, motile Gram negative bacteria. In stained faecal smears (1% basic fuchsin), the organisms have been likened to the wings of gulls and some forms appear 'S' or comma shaped. As the organisms develop they become longer and look more like spirochaetes. The different forms are shown in colour Plate 15.

**Note:** The distinctive appearance of campylobacters in a basic fuchsin stained faecal smear (containing blood and pus cells) enables a presumptive diagnosis of *Campylobacter* enteritis to be made. A specimen should be sent to a Public Health Laboratory for isolation of the pathogen by culture.

**Campylobacter isolation techniques**

Campylobacters can be isolated from faecal specimens by using:

- A filtration technique and a non-selective culture medium. A filter of 0.47 µm pore size will retain faecal commensals and allow campylobacters to pass through.

- A selective culture medium that contains antimicrobials to inhibit the growth of faecal commensals.

#### **Filtration technique to recover campylobacters**

This technique requires the use of a cellulose acetate 0.45 µm porosity, 47 mm diameter membrane filter\*.

\*Obtainable from AJ Cope & Sons, code 7000-0004). For contact details, see Appendix 11.

The technique (Steel and McDermott)<sup>1</sup> is as follows:

- 1 Emulsify about 1 g of faeces in 10 ml of sterile saline. If available use a Vortex mixer. Allow to settle for 2 minutes.  
*Note:* If a fluid specimen, there is no need to mix it with saline.
- 2 Place a filter membrane of 0.45 µm porosity, 47 mm diameter (see previous text) on a plate of blood agar or chocolate (heated blood) agar.
- 3 Add about 10 drops of faecal suspension to the filter, making sure the suspension does not over-run beyond the edge of the filter.
- 4 Remove and discard the filter 30–60 minutes after applying the suspension.
- 5 Incubate the plate in a microaerophilic environment (see subunit 7.4), preferably at 42–43 °C for up to 48 h or if this is not possible at 37 °C.

#### **Use of selective culture media containing antimicrobials to isolate campylobacters**

Several different blood-based and non-blood-based media containing different antimicrobial supplements and growth factors have been developed for the isolation of campylobacters from faecal specimens.

##### **Examples:**

- *Blaser's medium:* Containing 10% sheep blood, vancomycin, trimethoprim, polymyxin B, cephalothin, amphotericin B. Brucella agar base has been recommended.
- *Skirrow's blood agar:* Containing lyzed horse blood, vancomycin, polymyxin B, trimethoprim. Blood agar base, e.g. No. 2 Oxoid is used.
- *Butzler virion medium:* Containing defibrinated sheep blood, cefoperazone, rifampicin, colistin, amphotericin B. Columbia agar base is used.
- *Improved Preston blood free-medium:* Containing cefoperazone and amphotericin B. This supplement is added to a *Campylobacter* blood-free agar base containing bacteriological charcoal, ferrous sulphate, sodium deoxycholate, sodium pyruvate, casein hydrolysate, nutrient broth and agar. Isolations are best on this medium when cultures are incubated at 37 °C rather than 42–43 °C.<sup>2</sup> Other workers have found superior results with initial incubation of 24 h at 37 °C followed by a further 24 h at 42 °C.

*Note:* In a comparison of the above media (and three others) Merino *et al* found the Improved Preston blood free medium yielded the greatest number of *C. jejuni* isolations.<sup>3</sup> The supplement (amphotericin B and cefoperazone) for this medium is available from Pro-Lab Diagnostics (see Appendix 11), code PL499 (10 vials). Each vial makes 3 ml to be added to 500 ml of medium. When reconstituted, the supplement can be kept for up to 2 weeks at 4–8 °C or for several months if frozen (in aliquots as needed). The Preston *Campylobacter* blood-free agar base is available from Oxoid (see Appendix 11), code CM739B (500 g).

Antimicrobial supplements for making other *Campylobacter* selective media are available from Oxoid Ltd, Pro-Lab Diagnostics, Mast Group, and other suppliers (see Appendix 11). Each supplement, depending on supplier is for use with 500 ml or 1 litre of medium. When 500 ml of medium is not required, store the supplement frozen (in convenient amounts).

#### **Culture**

*Campylobacter* species are strictly microaerophilic, requiring incubation in an atmosphere of reduced oxygen (5–10%) with added carbon dioxide (about 10%). Simple inexpensive ways of obtaining microaerophilic conditions are described in subunit 7.4.

*C. jejuni* and *C. coli* are thermophilic, i.e. they will grow at 42–43 °C and 36–37 °C but not at 25 °C. Incubation at 42–43 °C helps to identify *C. jejuni* and *C. coli*. However, when using Improved Preston blood-free selective medium, (see above text), isolations of campylobacters are increased when cultures are incubated at 37 °C.

**Blood agar:** *C. jejuni* and *C. coli* produce non-haemolytic spreading, droplet-like colonies on blood agar as shown in colour Plate 17. Examine the colonies microscopically for campylobacters and perform an oxidase test.

#### **Improved Preston blood-free medium:**

*C. jejuni* produces grey, moist, flat-spreading colonies. Some strains may have a green hue or a dry appearance with or without a metallic sheen. *C. coli* usually produces creamy-grey, moist, slightly raised colonies. A swarming growth may occur. Examine the colonies microscopically and perform an oxidase test.

#### **Biochemical tests**

*Campylobacter* species are oxidase and catalase positive. A presumptive diagnosis of *Campylobacter* enteritis can be made by isolating oxidase and catalase positive colonies (from a selective medium or faecal suspension filtrate cultured on a non-selective medium), showing typical *Campylobacter* morphology.

**Hippurate hydrolysis:** If required, this test (e.g. using a Rosco diagnostic tablet, code 56711) can be used to differentiate *C. jejuni* from *C. coli*. Hippurate is hydrolyzed by *C. jejuni* and not hydrolyzed by *C. coli*.

### Latex agglutination test to identify *Campylobacter*

A *Dryspot Campylobacter* latex agglutination test kit (code DR 0150) is available from Oxoid (see Appendix 11) for the identification of enteropathogenic *Campylobacter* species from solid culture media. The latex reagent is dried on reaction cards. The test kit includes the antigen extraction reagents required to perform the test. Each test pack contains 50 tests.

### Antimicrobial susceptibility

Most *Campylobacter* strains are susceptible to erythromycin, ciprofloxacin and aminoglycosides. Resistance is being reported from some countries to ciprofloxacin, tetracyclines, ampicillin and cotrimoxazole. *Campylobacter* infections, however, are often self-limiting and do not require antimicrobial treatment.

#### REFERENCES

- 1 **Steel TW, McDermott SN.** Technical note: the use of membrane filters applied directly to the surface of agar plates for the isolation of *Campylobacter jejuni* from faeces. *Pathology*, 16, pp. 263–265, 1984.
- 2 **Bolton FJ, Hutchison DN, Parker G.** *European Journal of Clinical Microbiological Infectious Disease*, 7, pp. 155–160, 1988.
- 3 **Merino FJ, Agulla A et al.** Comparative efficacy of seven selective media for isolating *Campylobacter jejuni*. *Journal of Clinical Microbiology*, 24, pp. 245–452, 1986.

---

## *Helicobacter pylori*

Infection with *H. pylori* (formerly *Campylobacter pylori*) is widespread. In developing countries, 8 in 10 children by age 5 y, and more than 90% of adults are infected. Transmission is by person to person contact, and probably also by contaminated water and food.

In most persons, infection with *H. pylori* is asymptomatic. In others, colonization of the internal surface lining of the stomach wall causes inflammation and chronic gastritis (non-immune, type B) which predispose to ulceration. *H. pylori* is thought to be the cause of most gastric and duodenal ulcers (eradication of *H. pylori* results in cure and reduces ulcer recurrence in 90% of peptic ulcer patients). *H. pylori* with other factors is also thought in some patients to be involved in the development of gastric cancer and gastric lymphoma (rare condition). In developing countries, *H. pylori* may also contribute to diarrhoea, malnutrition and growth failure in young children (reduced gastric acid protection leads to infection with enteropathogens).

**Specimens:** To isolate *H. pylori* by culture a gastric biopsy is required. Place a biopsy of mucosa from the gastric antrum in a bottle containing about 0.5 ml of sterile physiological saline. It should reach the laboratory with the minimum of delay.

**Gastric biopsy smear:** *H. pylori* appears as a small (2–6.5 µm long) spiral or S-shaped Gram negative bacterium. The organism can also be stained using Giemsa stain.

### Culture and biochemical reactions

Isolation of *H. pylori* may occasionally be required in the investigation of gastric disease. Using a sterile scalpel and forceps, cut the biopsy into small pieces. Inoculate a plate of chocolate (heated blood) agar or *Campylobacter* medium, and also place a piece of biopsy in Christensens urea broth (see No. 25). Testing for urease activity can also be performed on the ward when performing an endoscopy using a commercially produced test, e.g. CLO (*Campylobacter*-like organisms) test, marketed by Tri-Med specialities.

*H. pylori* is a microaerophile, requiring culture in a moist carbon dioxide environment. It grows slowly, forming grey translucent colonies, resembling those of *H. influenzae*, within 3–7 days. On blood agar, colonies are slightly beta-haemolytic. Growth is best at 37°C. Test the colonies as follows:

- Gram or Giemsa stain the culture
- Perform catalase, oxidase, and urease tests.

**Note:** A presumptive identification of *H. pylori* from a primary culture can be made by demonstrating spiral shaped organisms that are catalase and oxidase positive and show strong urease activity. If required, perform antimicrobial susceptibility testing, particularly to test for metronidazole resistance. Treatment (using several antimicrobials) to eradicate *H. pylori* infection is difficult.

### Histology

When indicated (to investigate gastric lesion), send a gastric biopsy, preserved in 10% formol saline to a Histopathology Laboratory.

### Serology

Several enzyme-based and rapid latex agglutination tests have been developed to detect *H. pylori* antibodies in serum. They are expensive and are of limited value in the investigation and follow-up of *H. pylori* associated disease in developing countries where most people are infected with *H. pylori*. Also the antigen reagent in commercially produced tests may not be reactive to antibodies produced by local *H. pylori* strains. Antigen tests which detect *H. pylori* antigen in faecal samples are also available but as yet there are no results of field evaluations from developing countries.

### Urease breath test

This non-microbiology test may be performed in specialist gastroenterology centres. The patient ingests <sup>13</sup>C or <sup>14</sup>C radio-labelled urea. Any carbon dioxide produced by urease-producing *H. pylori* is detected in the breath using a mass spectrometer or a scintillation counter.

## 7.18.22 *Yersinia pestis*

### Pathogenicity

*Y. pestis* causes plague, a zoonotic disease which is transmitted from rats and other rodents to humans by infected fleas (main vectors: *Xenopsylla cheopis*

and *X. brasiliensis*). Occasionally, infection occurs by inhaling the organisms in airborne droplets, or by handling infected rodents or domestic animals (e.g. cats, dogs) that harbour infected fleas. There are three main forms of the disease:

- **Bubonic plague:** This is the commonest form and is characterized by high fever and acute lymphadenitis with painful haemorrhagic swellings called buboes, usually in the groin area. Occasionally lymph nodes in the neck or armpits are involved, depending on the site of the flea bite. There is a markedly raised white cell count with neutrophilia.
- **Pneumonic plague:** This occurs following inhalation of the organism or its spread to the lungs via the blood stream. Pulmonary infection causes severe bronchopneumonia with haemorrhaging. It is rapidly fatal unless treated at an early stage. Pneumonic plague is highly infectious and can spread quickly in conditions of poverty and overcrowding. The sputum contains large numbers of plague bacilli and is often blood stained.
- **Septicaemic plague:** This is a serious haemorrhagic condition in which large numbers of *Y. pestis* are present in the blood. The organisms can often be seen in peripheral blood smears. Buboes are usually absent. There is a haemorrhagic rash. Septicaemic plague is rapidly fatal.

**Note:** The clinical features of bubonic and pneumonic plague may sometimes resemble the suppurative skin nodule (at site of infection) and necrotizing pneumonitis associated with melioidosis (caused by *Burkholderia pseudomallei*). Melioidosis is found mainly in Southeast Asia. Like *Y. pestis*, *B. pseudomallei* also shows bipolar staining (see end of subunit 7.18.20). Knowing the case history is most important in making an early presumptive diagnosis of plague when bipolar stained organisms are detected in bubo aspirates.

#### Outbreaks of plague

Areas of the world where wild rodent plague exists, e.g. parts of North and South America, Madagascar, Africa, India, central and Southeast Asia, are high risk areas for human plague. In some parts of Africa the incidence of plague is increasing. Outbreaks occur when humans come into close contact with infected rodents and their fleas, e.g. following man-made or natural disasters, or when rodents infest poorly constructed homes and there are no flea or rodent control measures, or when deforestation or other situations force rodents closer to where people live. Humans are also at risk following rodent plague epidemics when the fleas leave dead rodents and infest humans.

#### LABORATORY FEATURES

**Caution:** *Y. pestis* is a highly infectious (Hazard Risk Group 3) pathogen, therefore handle specimens with care. Minimize the creation of aerosols. Whenever possible, carry out procedures in a safety cabinet (see pp. 64–65 in Part 1 of the book). When plague is suspected, notify the Central Public Health Laboratory. Isolation of the organism should be carried out in this laboratory.

**Specimens:** These include bubo aspirates, sputum, and blood for culture. When septicaemic plague is suspected, also collect blood into EDTA (sequestrene) to examine blood smears for bipolar stained organisms.

Specimens should be collected before antibiotic treatment is started. When sending to a Public Health Laboratory, bubo aspirates and blood (in appropriate broth) should be sent in an insulated container with an ice pack (see p. 65 in Part 1 of the book). Sputum specimens should not be sent. A *full case history* must accompany the specimen together with a report of the microscopical examination of the aspirate or blood, i.e. whether bipolar stained organisms were seen.

#### Morphology

*Y. pestis* is a small Gram negative, non-motile coccobacillus, measuring about  $1.5 \times 0.7 \mu\text{m}$ . It is capsulated and in smears from specimens, shows bipolar staining (safety pin appearance) when stained with methylene blue (see 7.3.7), Giemsa (see 7.3.10), or Wayson's rapid stain (see 7.3.8), see colour Plate 54. When seen in blood smears, it is extracellular. Smears should be methanol-fixed for 5 minutes.

#### Culture

*Y. pestis* is an aerobe and facultative anaerobe. It grows over the temperature range 14–37 °C with an optimum of 27 °C. Cultures should therefore be incubated at *room temperature*.

**Blood agar:** *Y. pestis* grows well on blood agar, producing small shiny, non-haemolytic colonies after 24–48 h incubation at room temperature.

**MacConkey agar:** Very small translucent *pink* colonies are formed after 24–48 h incubation. *Y. pestis* does not ferment lactose but appears 'lactose-fermenting' because it takes up the red dye of the indicator in the medium.

**Broth cultures:** Subculture on to blood agar after overnight incubation and examine stained smears microscopically. The organisms form chains.

*Note:* Other culture media may be used in specialist microbiology laboratories to isolate *Y. pestis*, e.g. *Yersinia* selective medium (CIN agar) and congo red agar. If colonies are to be tested for F1 (Fraction 1) capsular antigen, cultures require incubation at 37°C to produce the antigen.

### Biochemical tests

*Y. pestis* is catalase positive and oxidase negative. The oxidase reaction is helpful in differentiating *Y. pestis* from *B. pseudomallei* which is oxidase positive (see end of subunit 7.18.20). A microbiology specialist laboratory is required to identify *Y. pestis*.

### Dipstick test to diagnose plague

A rapid easy to perform immunochromatographic strip test (dipstick) has been developed by the Institut Pasteur to detect specific antigen to *Y. pestis* in bubo aspirates and sputum in bubonic and pneumonic plague. The test takes 15 minutes to perform. The dipsticks can be transported and stored at room temperature (4–25°C). The dipstick antigen test can also be used to test samples from rats. The test has been reported as having a sensitivity and specificity of 100%.

**Availability:** Details can be obtained from Institut Pasteur of Madagascar, WHO Collaborating Centre for Plague, Antananariva, Madagascar.

### Antimicrobial susceptibility

Antimicrobials with activity against *Y. pestis* (early stages of infection) include streptomycin, tetracycline and chloramphenicol. Some strains show resistance to streptomycin and tetracycline. *Y. pestis* strains have also been reported showing resistance to other antimicrobials.

#### FURTHER INFORMATION

*Plague overview.* WHO Fact sheet No. 267, 2005. Can be downloaded from WHO website [www.who.int](http://www.who.int) (use Search facility to locate the Fact sheet).

### *Yersinia enterocolitica*

*Y. enterocolitica* causes gastroenteritis, mainly in infants and young children, and occasionally acute mesenteric lymphadenitis. Enteric infection usually produces a watery diarrhoea. Some strains, however, are invasive and toxigenic, producing an inflammatory reaction with dysentery. In adults, infection is usually accompanied by lower abdominal pain, fever, and leucocytosis which may suggest acute appendicitis. The pathogen is more commonly found in temperate climates but *Y. enterocolitica* infections have been reported from South Africa, Zaire, and Nigeria. *Y. enterocolitica* can multiply in food refrigerated at 4–8°C.

*Y. enterocolitica* is a Gram negative coccobacillus which shows

bipolar staining. When cultured at 22°C it is motile and non-motile at 37°C. It is an aerobe and facultative anaerobe.

A selective medium such as MacConkey agar, CIN (cef-sulodin-Irgasan-Novobiocin) agar, or SS agar is required to isolate *Y. enterocolitica* from faecal specimens. After 24–48 h incubation at 20–28°C (room temperature), *Y. enterocolitica* produces small non-lactose fermenting colonies.

### Identification of a suspect *Y. enterocolitica* isolate

- 1 Subinoculate two tubes of urea broth (see No. 25) and incubate one at room temperature (20–28°C) and the other at 35–37°C overnight.  
Subinoculate a tube of KIA (see No. 45), and incubate at room temperature overnight.
- 2 Perform an oxidase test and a catalase test.
- 3 Examine a Giemsa or Wayson stained smear for coccobacilli showing bipolar staining.

An isolate can be identified presumptively as *Y. enterocolitica* if it is motile at 20–28°C but non-motile at 35–37°C, urease positive (usually after overnight incubation), oxidase negative, and gives a red slope and yellow butt with no gas production or blackening in KIA. Most strains show bipolar staining.

*Note:* Other biochemical reactions of *Y. enterocolitica* are shown in Chart 7.10 in subunit 7.18.14.

## 7.18.23 *Brucella* species

Brucellosis or undulant fever, is a zoonosis, caused by:

- *B. melitensis* which occurs more frequently and is the most virulent species. It is mainly a pathogen of goats and sheep. It has also been found as a bovine pathogen in intensive dairy farms.
- *B. abortus* which infects mainly cattle but can also be transmitted to other animals, including sheep, goats, camels, yaks, pigs, dogs.
- *B. suis* which is mainly found in pigs.

*Note:* Less commonly brucellosis is caused by *B. canis* which infects dogs.

### Human brucellosis

Brucellae are intracellular organisms infecting reticuloendothelial cells of the spleen, liver, kidneys and bone marrow. From these sites, the bacteria pass into the blood. The disease is characterized by fever which may be continuous, intermittent, undulating or irregular. Acute infection may resemble severe influenza with headache, sweating (especially at night) and generalized pains associated with fatigue and depression. Urogenital symptoms may occur in some patients and rarely neurological symptoms. Often the patient is anaemic and leukopenic with a relative lymphocytosis. Untreated infections can become chronic with musculoskeletal symptoms (back pain, arthritis, arthralgia). Heart valves may become

involved, leading to endocarditis. An immune complex syndrome may develop.

Human brucellosis can occur when brucellae are ingested in raw milk, fresh cheese, cream or other milk products (large numbers of organisms are shed in the milk of infected animals), enter damaged skin or the eye, or are inhaled in aerosols. Those working with animals are particularly at risk. Also nomadic herdsmen and those who drink animal blood and untreated milk from infected animals or eat fresh products produced from raw milk. Brucellae can be killed in milk by boiling or pasteurization.

Brucellosis is endemic in those parts of the world where brucellosis in animals has not yet been eradicated. It is endemic in the developing areas of the Mediterranean Region, Middle East, western Asia and parts of Africa and Latin America. In many developing countries, human brucellosis continues to be undiagnosed.

## LABORATORY FEATURES

**Caution:** Brucellae are highly infectious (Hazard Risk Group 3) pathogens. Laboratory-acquired infections can occur following accidental inoculation or inhalation of the organisms. Collect blood with great care, minimize the creation of aerosols and whenever possible, carry out procedures which may produce aerosols in a safety cabinet (see pp. 64–65 in Part 1 of the book).

**Specimens:** Blood or bone marrow (iliac crest specimen) for culture in the acute stage of infection. Brucellae multiply faster in bone marrow cultures, and when the patient has received antibiotics, the organism are more likely to be isolated from bone marrow than blood. Blood cultures are more commonly positive in *B. melitensis*\* and *B. suis* infections.

\**B. melitensis*: Is found in the Mediterranean littoral, Arabian Gulf, India, Southwest Asia, parts of Latin America (e.g. Peru) and Mexico.

Serum is required to diagnose brucellosis serologically.

## Morphology

Brucellae are small Gram negative non-capsulated coccobacilli or short rods. They do not show bipolar staining but may stain unevenly.

## Culture

*Brucella* species are difficult to isolate, particularly *B. abortus* (rarely isolated from blood culture). The organisms are more likely to be isolated from the blood in acute brucellosis during times of fever. Isolation is extremely rare in chronic brucellosis.

Tryptone soya (tryptic soy) diphasic medium (Castaneda) is recommended for the isolation of *Brucella* species. Several commercially produced

blood culture systems are also suitable and some provide rapid isolation. Brucellae are aerobic with *B. abortus* requiring a carbon dioxide enriched atmosphere. They grow over a temperature range 20–40°C with an optimum of 37°C. Cultures should be kept for 4 weeks with subculturing every few days. When subcultured on solid agar, colonies usually appear 2–3 days after incubation.

A variety of colonial forms are produced by *Brucella* strains including smooth, mucoid, and rough colonies. They may be colourless or grey-white. Subculturing on a slope of glucose tryptone agar with a lead acetate test strip in the neck of the tube is useful in testing for hydrogen sulphide (H<sub>2</sub>S) production. *B. melitensis* is H<sub>2</sub>S negative, most strains of *B. abortus* and *B. suis* are H<sub>2</sub>S positive.

**Note:** Ability to grow on tryptone soya agar containing varying concentrations of dyes such as basic fuchsin and thionine, can be used to assist in the differentiation of *Brucella* species. Dye tests and the use of monospecific antisera of different *Brucella* species should be performed in a specialist microbiology laboratory.

## Biochemical tests

Only a few routine biochemical tests are helpful in differentiating *Brucella* species. All *Brucella* strains are catalase positive and usually oxidase positive (some strains of *B. abortus* are oxidase negative). They are indole negative and most strains hydrolyze urea.

## Serological diagnosis of brucellosis using rapid Ig M/IgG immunochromatographic assay

A rapid and easy to perform immunochromatographic test in cassette form has been developed recently by the Royal Tropical Institute (KIT) in Amsterdam to diagnose acute, subacute, chronic, and relapsing brucellosis. It can also be used to monitor treatment. The assay detects separately *Brucella* specific IgM and IgG antibodies. IgM antibodies develop early in brucellosis and remain present for several weeks to months following recovery. IgG antibodies develop later and can persist for months to years after recovery. During and following treatment, antibody reactivity decreases. After 6 months, antibody levels are low or undetectable.

The IgM/IgG immunochromatographic assay is performed by adding 5 µl patient's serum to the sample well of the test device followed by running fluid reagent. The result is read after 10–15 minutes. A positive test is indicated by the appearance of two pink lines, an upper line in the control area and a lower line in the test area. The intensity of colour reaction in the test area corresponds to the level of antibody, with a weak colour reaction being



recorded as 1+ antibody reactivity, a moderate reaction as 2+, strong reaction as 3+ and a very strong reaction as 4+.

Sensitivity of the test is increased when both IgM and IgG assays are used. In acute brucellosis when a person has been ill for less than 2 months only the IgM assay may be positive. As the disease progresses the IgG assay will also become positive. In chronic and relapsing brucellosis, IgG antibodies predominate. When an assay is weakly positive, it should be repeated to confirm active brucellosis. In brucellosis endemic areas, non-brucellosis persons working closely with animals may give weak antibody reactions. Unlike agglutination tests, IgM/IgG immunochromatographic assays are reported as showing no significant cross-reactions when testing samples from patients with illnesses other than brucellosis. Specificity of the IgM/IgG assays is reported as 99–100% and sensitivity as 96–100%.

The assays do not require cold chain transportation and storage. They can be kept at ambient temperature (up to 25 °C). They need to be protected from direct sunlight and only removed from their moisture-proof pouch when ready to be used. The test devices and running fluid reagent have a 2 year shelf-life from date of manufacture.

**Availability:** Two assay kits are available, one to detect *Brucella* specific IgM antibodies and the other to detect specific IgG antibodies. Each kit contains 25 individually packaged test cassettes with 1 bottle of running fluid reagent. The assays are produced by and available from KIT (Royal Tropical Institute) Biomedical Research Unit. See Appendix 11 for contact details.

#### Agglutination tests used to test serum for *Brucella* antibodies

- Rapid slide screening agglutination test
- Tube or microplate agglutination test

*Note:* whenever possible obtain antigen reagents that have been prepared from local *Brucella* strains.

#### Rapid slide agglutination test

This is a useful rapid screening test to detect a reactive serum which requires titrating. It should not replace the standard tube agglutination test nor be used to determine the *Brucella* antibody titre. To avoid a false negative result due to the prozone phenomenon (see following text), both neat and diluted serum samples should be tested.

#### Standard tube or microplate agglutination test

This test is required to determine the antibody titre. It should also be performed when a patient with a negative slide test continues to show symptoms of brucellosis. The technique for the standard tube test will be provided by the manufacturer of the antigen reagents. Usually two-fold dilutions of serum from 1 in 20 to 1 in 640 in 0.4% phenol saline are tested. Most tube tests are read after 24–48 h incubation at 37°C. Control positive and negative *Brucella* sera must be included with each batch of tests.

**Prozone reaction:** The standard tube agglutination titration test detects Ig M and Ig G antibodies. When the antibody level is markedly raised, as can occur in acute brucellosis, only the higher dilutions (i.e. over 1 in 40 or 1 in 80) may show agglutination. This is referred to as a prozone reaction, or phenomenon.

**False positive agglutination reactions:** These may occur when testing serum that contains antibodies to *V. cholerae*, *F. tularensis*, *Y. enterocolitica* and some *E. coli* strains and *Salmonella* serovars.

#### Positive result

A titre of 1 in 160 is often taken as indicating active brucellosis. In some endemic areas, however, a minimum titre of 1 in 320 is used as indicative of disease. This should be decided locally.

#### Antimicrobial susceptibility

Brucellae are susceptible to many antimicrobials. Because the organisms are intracellular, they are difficult to eradicate. Tetracycline combined with streptomycin is the usual treatment. Antimicrobial resistant strains of *Brucella* have been reported.

#### FURTHER INFORMATION

**Irmak H et al.** Use of the *Brucella* Ig M and Ig G flow assays in the serodiagnosis of human brucellosis in an area endemic for brucellosis. *American Journal Medicine & Hygiene*, 70(6), pp. 688–694, 2004.

## 7.18.24 *Haemophilus influenzae*

#### Pathogenicity

In developing countries invasive infections with capsular type b *H. influenzae* are major causes of ill health and premature death in infants and young children. Infections are usually bacteraemic.

*H. influenzae* type b causes:

- Pyogenic (purulent) meningitis in young children below 5 y.
- Pneumonia and empyema (mainly adults).
- Acute epiglottitis (acute inflammatory swelling of the epiglottis and neighbouring structures) which may cause fatal airway obstruction.
- Cellulitis (orbital), septic arthritis, and occasionally other invasive infections.

Non-typable *H. influenzae* strains are mainly responsible for chronic bronchitis (usually in adults), middle ear infections, paranasal sinusitis, and conjunctivitis. These strains form part of the normal microbial flora of the upper respiratory tract in 50–75% of persons. The carrier rate for capsulated b strains is about 2–4%.

## LABORATORY FEATURES

**Specimens:** These include cerebrospinal fluid (c.s.f.), nasopharyngeal specimens, pus, and blood for culture. Specimens must be cultured as soon as possible and not refrigerated.

### Morphology

*H. influenzae* is a small non-motile Gram negative coccobacillus or short rod. Long thread-like and pleomorphic forms may be seen in c.s.f. (with pus cells), or following culture. A Gram stained smear of *H. influenzae* in c.s.f. is shown in colour Plate 48. It is best stained using dilute carbol fuchsin as the counter-stain. The capsule which surrounds capsulated strains can be demonstrated by using specific antiserum.

### Culture

*H. influenzae* grows poorly anaerobically. Growth is best achieved in a moist carbon dioxide enriched atmosphere (see subunit 7.4). The temperature range of growth is 20–40°C with an optimum of 35–37°C. Media used to grow *H. influenzae* must contain haemin or other iron-containing porphyrin and nicotinamide adenine dinucleotide (NAD) or its phosphate (NADP). The porphyrin requirement is referred to as growth factor X and the NAD or NADP requirement as growth factor V.

#### Factors X and V

Factor X is used by *H. influenzae* to produce essential respiratory enzymes such as cytochromes, catalase, and peroxidase. Factor V is used as an electron carrier in the organism's oxidation-reduction system.

**Chocolate agar:** After overnight incubation at 35–37°C in a moist carbon dioxide atmosphere, capsulated *H. influenzae* strains produce mucoid colonies, 1.5 mm or more in diameter. See colour Plate 49. Cultures have a distinctive smell.

*H. influenzae* grows well on chocolate agar because it contains factors X and V. Heating blood agar to 75°C inactivates serum NADase and releases extra factor V from the red cells. Addition of bacitracin (300 mg/litre) provides a selective medium to recover *H. influenzae* from sputum. This is not needed when culturing c.s.f.

**Note:** *H. influenzae* produces very small colonies on horse or rabbit blood agar (colonies may appear beta-haemolytic). There is usually no growth on sheep blood agar. If, however, *S. aureus* which produces factor V in excess of its own needs, is cultured on a blood agar plate with *H. influenzae*, the factor V and the haemin released by staphylococcal haemolysins help the growth of *H. influenzae*. This 'help' given by *S. aureus*, forms the

basis of the satellitism test which is a simple way of recognizing *H. influenzae* (see following text). *S. pneumoniae* also produces factor V and causes *H. influenzae* to show satellitism.

Alternatively, *H. influenzae* can be identified by its requirement for factors X and V using factor identification tablets or discs (see later text).

### Satellitism test to identify *H. influenzae*

- 1 Mix a loopful of suspect *Haemophilus* growth in about 2 ml of sterile physiological saline or sterile peptone water. Make sure none of the chocolate agar medium is transferred.
- 2 Using a sterile swab, inoculate the organism suspension on a plate of nutrient agar or tryptic soya agar, and a plate of blood agar.
- 3 Streak a pure culture of *S. aureus* across each of the inoculated plates.
- 4 Incubate both plates in a carbon dioxide enriched atmosphere at 35–37°C overnight.
- 5 The following morning examine the cultures for growth and satellite colonies.

*H. influenzae*: shows growth on the blood agar plate but not on the nutrient agar plate, and the colonies near the column of *S. aureus* growth are larger than those furthest from it (see colour Plate 52).

If satellite colonies are present on both plates the organism is probably an *Haemophilus* species that requires only factor V, such as *H. parainfluenzae*.

Very occasionally, satellitism is shown by strains of *Neisseria*, *Streptococcus* species, and diphtheroids.

**Note:** A rapid presumptive identification of *H. influenzae* by satellitism can often be made if *S. aureus* is inoculated on two or three small areas of a primary culture plate.

#### X and V Requirements of *Haemophilus* Species

Species	Factor X	Factor V
<i>H. influenzae</i> and <i>H. influenzae</i> biogroup aegyptius	+	+
<i>H. parainfluenzae</i>	–	+

### Identification of *H. influenzae* using X, V, XV discs or tablets\*

\*Stable (long-life) tablets containing factors X, V and XV are available from Rosco Diagnostica (codes 425 11, 426 11, 427 11), see Appendix 11.

#### Method

- 1 Make a saline suspension (approx. 0.5 McFarland turbidity) of the test organism from a

primary culture. Take care *not* to transfer any chocolate agar medium. Using a swab, inoculate the suspension on a plate of blood agar base (without the blood) or nutrient agar known to lack factors X and V.

- Place the factor tablets or discs 10–20 mm in from the side of the plate, positioning each disc/tablet as follows:

Factor X. . . . . at '12 o'clock'

Factor V. . . . . at '4 o'clock'

Factor XV . . . . . at '8 o'clock'

- Set up a control plate using a known *H. influenzae* strain.
- Incubate the plates overnight in a moist carbon dioxide atmosphere at 35–37°C.
- Examine the plates for growth around each tablet or disc (see colour Plate 53).

*H. influenzae*: Growth around factor XV and slight growth between X and V

*H. parainfluenzae*: Growth around factor XV and factor V

Report the test results when the control plate shows the correct reactions for *H. influenzae* (see colour Plate 53). When the culture medium contains traces of factor X, the reactions will show those of *H. parainfluenzae*. When this occurs it is best to perform a more reliable test to detect factor X requirement, such as the porphyrin (*d*-ALA) test. This can be simply performed using a Rosco Diagnostic tablet (code 573-21).

#### Iridescence of *H. influenzae*

When subcultured on a transparent medium such as Levinthal agar (see No. 49), colonies of capsulated *H. influenzae* organisms show iridescence when a beam of white light is directed from the side through the underside of the colonies.

The iridescence is thought to be due to the optical properties of the capsular layers. It is seen as different shades of red, orange, green, and blue that change with the angle of observation. It is best seen in young (4–6 h) cultures. Colonies showing iridescence on Levinthal agar can be identified as *H. influenzae* by slide agglutination using specific antiserum.

#### Biochemical tests

Biochemical techniques are not used routinely to identify *Haemophilus* species.

Six biotypes of *H. influenzae* are recognized based on the indole, urease, and ornithine decarboxylase (ODC) reactions of the different strains. More than 90% of type b strains are biotype 1.

#### Serology

*H. influenzae* organisms are divided into six serogroups, a–f. The majority of strains that cause

meningitis belong to invasive serogroup b. Very occasionally meningitis is caused by groups a, e, and f.

Most of the strains that cause chronic bronchial disease are non-capsulated. Serological reagents are commercially available for the identification of *H. influenzae* in cultures and specimens by agglutination techniques.

#### Detection of *H. influenzae* antigen in c.s.f

Slide coagglutination reagents are commercially available for the rapid immunological detection of specific polysaccharide *H. influenzae* b antigen in c.s.f. The test is rapid, easy to perform, specific and sensitive. A coagglutination test is available from Boule Diagnostics (see Appendix 11).

*Note*: Other c.s.f. tests used to assist in the identification of pyogenic meningitis are described in subunit 7.13.

#### Antimicrobial susceptibility

All strains of *H. influenzae* should be tested for *beta*-lactamase production (see end of subunit 7.16). Plasmid mediated *beta*-lactamase producing strains resistant to ampicillin are widespread. Resistance to chloramphenicol has also been reported. A wide range of antimicrobials continue to show activity against *H. influenzae*.

*H. influenzae* type b vaccine provides effective protection and has led to a reduction in the incidence of *H. influenzae* b infections in young children.

---

#### *Haemophilus influenzae* biogroup aegyptius

This biogroup of *H. influenzae* (*H. influenzae* biotype 111) causes acute and highly infectious conjunctivitis often referred to as 'pink eye'. A particularly virulent form of the organism (or *H. influenzae* capsular type c) is the cause of Brazilian purpuric fever (BPF), a rapidly fatal illness in young children. It is characterized by high fever, abdominal pain and vomiting, petechial or purpuric rash, vascular collapse and hypotensive shock leading to death. Outbreaks of the disease have occurred in Brazil and also in central and western Australia. Acute conjunctivitis preceded or accompanied the disease.

In acute conjunctivitis, *H. influenzae* biogroup aegyptius can be isolated from eye discharge and in BPF from blood culture. The organism closely resembles other *H. influenzae* organisms. It also requires factors X and V for isolation but it grows more slowly. Addition of 1% Isovitalax to chocolate agar improves its growth.

---

### *Haemophilus parainfluenzae*

*H. parainfluenzae* is a commensal of the upper respiratory tract. Occasionally it causes respiratory infections, endocarditis, pyogenic arthritis, and conjunctivitis, often as an opportunistic pathogen.

*H. parainfluenzae* differs from *H. influenzae* in requiring only factor V for its growth and not factor X. On chocolate agar it forms larger colonies than *H. influenzae*.

### *Moraxella catarrhalis*

*M. catarrhalis* (formerly *Branhamella catarrhalis*) is a normal commensal of the upper respiratory tract. As an opportunistic pathogen it occasionally causes upper and lower respiratory tract infections, mostly in immunocompromised patients and those with chronic bronchitis.

*M. catarrhalis* is a Gram negative coccus, diplococcus, or coccobacillus, possessing many of the features of neisseriae. As a pathogen it can be found with pus cells (sometimes intracellular) in sputum smears.

On blood agar and chocolate agar, *M. catarrhalis* produces distinctive grey-white, dry and brittle colonies which can be easily lifted off the medium with a wire loop. The organism is catalase positive and strongly oxidase positive. Many strains produce *beta*-lactamase.

## 7.18.25 *Haemophilus ducreyi*

### Pathogenicity

*H. ducreyi* causes chancroid, or soft sore. It is sexually transmitted and a common cause of genital ulceration in tropical countries (Asia, Africa, Central and South America). The ulcers are painful, shallow and tend to be ragged and bleed easily. Often there is also painful swelling of inguinal lymph nodes, and abscesses (buboes) may form. Chancroid increases the risk of infection with HIV and facilitates transmission of the virus.

### LABORATORY FEATURES

**Specimens:** Specimens should be collected from the base and margins of ulcers following cleansing with a saline swab (exclude necrotic tissue). Specimens for culture must be delivered to the laboratory with the *minimum* of delay. When this is not possible the swab should be placed in Amies transport medium and delivered the same day to the laboratory or sent in an insulated cool box to reach the laboratory within 48 h.

### Morphology

*H. ducreyi* is a Gram negative non-motile short rod or coccobacillus. It is pale staining, therefore Gram

smears should be counterstained with dilute carbol fuchsin (see subunit 7.3.4). When seen in smears, *H. ducreyi* may be found in pus cells or extracellularly, often in loose clusters, strands or parallel chains. It is, however, usually difficult to differentiate *H. ducreyi* from the other contaminating organisms which are usually seen in smears. The sensitivity and specificity of a Gram smear for *H. ducreyi* is low. Isolation of the organism by culture is required to diagnose chancroid definitively. Most infections are diagnosed clinically.

### Culture

*H. ducreyi* is difficult to isolate. The organism requires factor X but not factor V. Media recommended for the growth of *H. ducreyi* include chocolate (heated blood) agar containing 1% Isovitalex and vancomycin (3 µg/ml) to suppress Gram positive contaminants, and GC agar base with added haemoglobin, vancomycin, and fetal calf serum. Cultures require incubation in a moist CO<sub>2</sub> enriched atmosphere at 32–35 °C. The organism grows slowly, producing small grey-yellow or brown colonies usually within 2–4 days. They are difficult to emulsify and can be easily pushed across the surface of the medium. In most developing countries, culture of *H. ducreyi* is usually only possible in a specialist microbiology laboratory.

### Biochemical tests

*H. ducreyi* is:

- Slowly oxidase positive (colour develops after 15–20 seconds).
- Catalase, urease, and indole negative.
- Ornithine decarboxylase (ODC) negative.
- *delta*-Aminolevulinic acid (ALA), negative (showing requirement for factor X).

**Note:** ODC and *d*-ALA testing, can be simply performed using Rosco identification tablets.

### Antimicrobial susceptibility

Many strains of *H. ducreyi* are *beta*-lactamase producers. Ampicillin resistance is widespread and also multi-drug resistant strains have been reported (e.g. resistant to sulphonamides, streptomycin, chloramphenicol, tetracycline and ampicillin). The organism remains susceptible to several other antimicrobials.

### FURTHER INFORMATION

**Van Dyck E, Meheus AZ, Piot P.** *Laboratory diagnosis of sexually transmitted diseases*. WHO, 1999. ISBN 92 4 154501 1. Contains comprehensive chapter on the laboratory investigation of chancroid.

**Steen R.** Eradicating chancroid. *Bulletin of World Health Organization*, 79(9), pp. 818–825, 2001.

## 7.18.26 *Bordetella pertussis*

### Pathogenicity

*B. pertussis* causes whooping cough, an infection of the mucosa of the upper respiratory tract. Toxin from the organisms causes the secretion of mucus which leads to irritation and the spasms of coughing associated with the disease. There is a marked leucocytosis with an absolute lymphocytosis. Complications of infection include lung damage with emphysema, secondary infection leading to bronchopneumonia, bronchiectasis, convulsions and occasionally brain damage.

*Note:* *B. parapertussis* causes a milder form of whooping cough.

### LABORATORY FEATURES

Diagnosis of whooping cough can usually be made clinically. Only occasionally is the laboratory required to investigate *B. pertussis* infection.

*Specimens:* Preferably nasopharyngeal secretions collected by aspiration or a correctly taken pernasal swab.

### Morphology

*B. pertussis* is a small, non-motile, capsulated Gram negative coccobacillus. It may occur singly or in chains, and may show bipolar staining.

### Culture

*Bordetella* species are strict aerobes. Specimens for the isolation of *B. pertussis* must be cultured as soon as possible after they are collected. A selective and enrichment medium such as charcoal cephalixin blood agar (see No. 24) is recommended for the primary isolation of *B. pertussis*.

**Charcoal cephalixin blood agar:** When incubated for 2–6 days at 35–37°C in a moist aerobic atmosphere (see subunit 7.4), *B. pertussis* produces small pearly-grey, shiny (mercury-like), usually mucoid colonies.

*B. parapertussis* grows more rapidly and forms larger colonies than *B. pertussis*. It produces a pigment in the medium and is able to grow aerobically on blood agar and nutrient agar.

### Biochemical reactions

*B. pertussis:*

- Urease negative
- Does not reduce nitrate
- Oxidase positive

*B. parapertussis* is slowly urease positive (after 24 h) and oxidase negative.

*Note:* The facilities of a specialist microbiology laboratory are required to serotype *Bordetella* species.

### Antimicrobial susceptibility

Antimicrobials with activity against *B. pertussis* include erythromycin, chloramphenicol, tetracycline, and cotrimoxazole. Protection against whooping cough is by prophylactic vaccination.

## 7.18.27 *Bacteroides fragilis* and other Gram negative anaerobic rods

**New classification of Gram negative anaerobic non-sporing rods**  
*Bacteroides* species have been re-classified as follows:

- Genus *Porphyromonas* which contains *P. gingivalis* and other asaccharolytic pigmented species.
- Genus *Prevotella* which contains *P. melaninogenica* (previously called *Bacteroides melaninogenicus*), and other moderately saccharolytic species that are inhibited by 20% bile. Several species are pigment-producing.
- Genus *Bacteroides* which now contains only *B. fragilis* and its five subspecies (most important, *B. fragilis* subsp. *fragilis*). The *B. fragilis* group of organisms are saccharolytic and able to grow in 20% bile.

The genus *Fusobacterium* contains several new species of oral origin (details of these can be found in recently published microbiology textbooks). *F. necrophorum* and *P. nucleatum* are important in human infections.

The genus *Leptotrichia* contains a single species, *L. buccalis* (originally classified as *Fusobacterium buccalis*). Its pathogenic role is uncertain.

### Pathogenicity

Gram negative anaerobic non-sporing rods are found as commensals in the oropharynx, human gastrointestinal tract, and female genital tract. The anaerobic infections they cause are often opportunistic and polymicrobial.

- *B. fragilis*, usually with other pathogens, is associated with abdominal infections (particularly following surgery and abdominal injury), peritonitis, gynaecological infections (including

puerperal sepsis), lung and cerebral abscesses and other soft tissue infections.

- *P. melaninogenica* and other *Prevotella* species, *P. gingivalis*, and *Fusobacterium* species are associated with periodontal disease and gingivitis.
- *F. nucleatum*, *P. intermedia*, and possibly *L. buccalis* with *Borrelia vincenti*, cause Vincent's infection, an acute ulcerative gingivitis.
- Fusobacteria with other Gram negative anaerobic rods are found in a range of necrotizing conditions and ulcers (as well as periodontal infections).
- *Prevotella* and *Porphyromonas* species are associated with infections of the female genitourinary tract.

### LABORATORY FEATURES

Full laboratory identification of non-sporing anaerobic Gram negative rods is difficult and rarely required. Collins *et al* advises that in the clinical situation all that is essential is confirmation that anaerobes are involved. A simple report that 'mixed anaerobes are present, susceptible to metronidazole', usually suffices.<sup>1</sup>

**Specimens:** Include pus, exudate or infected tissue, and blood for culture. Specimens suspected of containing anaerobes (e.g. foul-smelling discharges) must be delivered to the laboratory as soon as possible and cultured anaerobically with the minimum of delay. If a long wave (365 nm) UV lamp is available, examining the specimen for brick-red fluorescence is helpful in indicating the presence of *P. melaninogenica*.

### Morphology

Gram negative non-sporing anaerobic rods are non-motile and often pleomorphic, staining irregularly (particularly *Bacteroides*). Some *Fusobacterium* species produce typical spindle-shaped fusiform rods. *L. buccalis* rods are long with tapering ends. In smears of pus from anaerobic infections large numbers of Gram negative rods of various sizes and shapes with rounded or pointed ends can usually be seen. Colour Plate 65 shows *B. vincenti* spirochaetes, fusiform and other Gram negative rods which can be seen in Vincent's infection.

### Culture

A selective medium is required to isolate Gram negative anaerobes from specimens which may contain contaminating facultative flora. Blood

agar can be made selective (depending on specimen) by adding neomycin (75 µg/ml), vancomycin (2.5 µg/ml), and, or, nalidixic acid (10 µg/ml). Addition of the growth factor menadione (1 µg/ml) is also recommended.

Placing a 5 µg metronidazole disc on the inoculum will provide a rapid identification of obligate anaerobes. Two plates should be inoculated, one for aerobic incubation and the other for incubation under strict anaerobic conditions (see subunit 7.4). Confirmation that the organism(s) will not grow aerobically can be made by incubating aerobically in a carbon dioxide enriched atmosphere.

**Blood agar** (selective/enriched): *B. fragilis* group produces grey, glistening, non-haemolytic, 1–2 mm diameter colonies usually within 48 h of anaerobic incubation. When the colonies are emulsified in 3% potassium hydroxide on a slide they become stringy, forming long strands when the loop is pulled away.

*Prevotella* species grow slower than *Bacteroides*. *P. melaninogenica* produces brown to black colonies after 3–7 days incubation. Young colonies fluoresce brick-red under longwave UV light. *Fusobacterium* species produce granular or striated colonies with irregular edges after about 48 h incubation. All Gram negative anaerobic rods will show susceptibility to metronidazole.

### Biochemical tests

Most biochemical tests are of limited value in identifying anaerobic Gram negative rods and as mentioned previously, in routine clinical work, it is usually sufficient to report the organisms as 'mixed anaerobes, sensitive to metronidazole' based on a Gram smear of the specimen and colonies, anaerobic growth, and metronidazole susceptibility. Further information on the laboratory investigation of infections caused by Gram negative anaerobic rods, can be found in *Microbiological methods*.<sup>1</sup>

### Antimicrobial susceptibility

Gram negative anaerobic rods are susceptible to metronidazole and most also to clindamycin, chloramphenicol and cefoxitin. *B. fragilis* group are penicillin resistant due to beta-lactamase production and also resistant to aminoglycosides. *P. melaninogenica* is resistant to kanamycin.

### REFERENCES

- 1 Collins CH, Lyne PM, Grange JM. *Microbiological methods*, 8th edition, 2004, Arnold publishing, ISBN 0 3408 0896-9

## 7.18.28 *Mycobacterium tuberculosis*

### **Mycobacterium tuberculosis complex**

*M. tuberculosis* is a complex of closely related organisms: *M. tuberculosis*, *M. bovis* and *M. africanum*. *M. bovis* is found mainly as a pathogen in cattle and occasionally in other animals. Humans become infected by close contact with infected cattle or by ingesting the organisms in raw untreated milk. Person to person transmission of bovine strains may also occur. *M. africanum* consists of several strains midway between *M. tuberculosis* and *M. bovis* and is found in equatorial Africa.

### **Pathogenicity**

*M. tuberculosis* causes tuberculosis. It infects a third of the world's population with 95% of those infected living in developing countries. In 2003, WHO estimated that there were 8.8 million new cases of tuberculosis with 1.75 million deaths (WHO Report 2005). Mortality rates are highest among children and young adults. Factors contributing to the high prevalence of tuberculosis in developing countries and problems in its control include co-infection with HIV (single most important factor), emergence of multi-drug resistant tuberculosis, inadequate treatment, continuing poverty, malnutrition, overcrowding, armed conflict, and increasing numbers of displaced persons.

### *M. tuberculosis* and HIV

Infection with HIV greatly increases the risk of developing tuberculosis and accelerates its progress. Progression to AIDS is also accelerated in those co-infected and HIV has a significant effect on the risk of relapse of tuberculosis. WHO estimates that tuberculosis causes up to 40% of AIDS deaths in sub-Saharan Africa and Southeast Asia. In sub-Saharan Africa, HIV is the most important cause of the increasing incidence of tuberculosis. Up to 70% of those with tuberculosis are also HIV positive.

### **Tuberculosis**

Most infections with *M. tuberculosis* are caused by inhaling cough droplets or dust particles containing tubercle bacilli which become lodged in the lung, forming an inflammatory lesion. Bacilli also infect adjacent lymph nodes. Activated macrophages form a granuloma around the site of primary infection which usually limits it. In most people the primary lesion is self-healing although not all the bacilli may be destroyed (some remain dormant in lymph nodes and may reactivate causing post-primary disease). There may be fibrous scarring and sometimes calcification of the healed area.

**Pulmonary tuberculosis:** This can occur when the primary infection does not heal completely and there is continued

multiplication or there is reactivation of organisms in the lung several months or years later due to poor health, malnutrition or defective immune responses. An inflammatory reaction leads to a liquefied destruction of lung tissue with caseation (breakdown of diseased tissue into a cheese-like mass). Erosion through the wall of a bronchus leads to the discharge of the liquefied tissue and the formation of a cavity. Bacilli multiply in the wall of the cavity and can be found in the sputum ('open' infectious stage). Patients with advanced infections have difficulty in breathing due to cavities in their lungs. In HIV-related tuberculosis with immunosuppression, it is common to find spreading pulmonary lesions without gross cavitation, non-pulmonary forms of the disease such as multi-organ involvement and non-symmetrical lymphadenopathy.

The main symptoms of pulmonary tuberculosis in adults are a chronic cough with the production of mucopurulent sputum which may contain blood (haemoptysis). In the later stages of the disease, there is loss of weight, fever, night sweats, fatigue, chest pain and anaemia. Complications include tuberculous pleurisy, pericarditis, and occasionally lung collapse.

In children, pulmonary tuberculosis is more difficult to diagnose because there is rarely a cough with sputum production. A diagnosis is usually made from a positive tuberculin reaction and X-ray. There is weight loss, and failure to thrive. Enlargement of the lymph glands may cause bronchial obstruction and occasionally a gland may rupture into a bronchus causing acute infection of the affected lung. Infection may progress to tuberculous meningitis.

**Tuberculous meningitis:** Tubercle bacilli reach the meninges in the blood. Tuberculous meningitis occurs more frequently in non-immune infants and young children as a complication of primary tuberculosis but it can occur at any age. The condition is often fatal unless treated at an early stage, but acid fast bacilli (AFB) are difficult to find in cerebrospinal fluid (c.s.f.). Lymphocytes are usually found (neutrophils in the early stages). Examination of c.s.f. and the results of biochemical tests in tuberculous meningitis are described in subunit 7.13.

**Miliary tuberculosis:** Widespread miliary infection can occur if a site of primary infection ruptures through a blood vessel and bacilli are disseminated throughout the body. Many small granulomata are formed which on a chest X-ray, look like millet seeds (hence name miliary tuberculosis). Patients are often acutely ill with fever but a chronic form of the disease can also occur. The liver, spleen and lymph glands may be enlarged and the meninges may also become infected.

**Renal and urogenital tuberculosis:** Tubercle bacilli reach the kidneys and genital tract by way of the blood circulation, usually some years following primary tuberculosis. Renal infection is often suspected when repeated urine specimens are found to contain pus cells but no organisms are isolated by routine culture. There may be frequency in passing urine, haematuria, and usually a recurring fever. Tuberculosis of the genital tract (epididymitis in males, endometrial tuberculosis in females) can cause infertility and pelvic inflammatory disease.

**Bone and joint tuberculosis:** A commonly infected site is the spine which may lead to the collapse of vertebrae and the formation of a 'cold' abscess in the groin. This form of the disease is rare.

## LABORATORY FEATURES

### *Importance of smear examination*

In developing countries, detecting infectious cases of tuberculosis by examining sputum for AFB, followed by adequate supervised treatment of smear positive individuals until they are completely cured, is the most effective way of reducing the transmission and infection rates of tuberculosis and spread of multi-drug resistant strains. In most developing countries, positive sputum smears due to mycobacteria other than the *M. tuberculosis* complex are rare. Cultural techniques for detecting *M. tuberculosis*, although more sensitive, are slow and expensive. Culture is principally carried out in Tuberculosis Reference Laboratories to investigate treatment failures and relapses and to monitor multi-drug resistance.

*Specimens:* Use screw-cap, leak-proof specimen containers (snap-closing containers are hazardous because they create aerosols). Sputum, not saliva is required to detect AFB. Examination of up to three specimens (at least one as an early morning specimen) may be required to detect the organisms. In AIDS patients, it is sometimes possible to detect AFB in buffy coat smears prepared from EDTA anti-coagulated blood. Cerebrospinal fluid is required to investigate tuberculous meningitis. Examination of gastric lavage from children is of limited value. When a specimen is for culture and susceptibility testing, the Tuberculosis Reference Laboratory should be consulted as regards sputum collection and transportation, and documentation to accompany the specimen.

*Note:* In those co-infected with HIV with associated immunosuppression, it may not be possible to detect AFB in sputum. The laboratory may be requested to examine pleural fluid. An exudative fluid containing lymphocytes with no organisms seen in the Gram smear supports a diagnosis of tuberculosis (with X-ray suggestive of tuberculosis). It is rare to find AFB in pleural fluid.

*Caution:* *M. tuberculosis* is a highly infectious (hazard Risk group 3) pathogen, therefore handle specimens with care. It is particularly important to minimize the creation of aerosols (see pp. 61–62 in Part 1 of the book) and to ensure the laboratory is well ventilated. The use of personal respirators should be considered to protect staff working with *M. tuberculosis*. Using a bleach centrifugation concentration technique (see subunit 7.6) not only improves the sensitivity of smear examination but also kills *M. tuberculosis*. When a Safety Cabinet is used this must be fitted with a high efficiency particulate air

filter (HEPA) and installed, used, and maintained correctly (see pp. 64–65 in Part 1 of the book). Use a hooded Bunsen burner when flaming wire loops. Smears however, can be more easily made using a wooden stick which can be easily discarded and incinerated after use.

### **Morphology**

*M. tuberculosis* is a non-sporing, non-capsulated straight or slightly curved slender rod, measuring 1–4 µm × 0.2–0.6 µm. Although it does not Gram stain well due to its waxy surface, the organism has a Gram positive cell wall. *M. tuberculosis* is best demonstrated using the Ziehl-Neelsen staining technique or a fluorescence technique.

### *Concentrating AFB in sputum*

Concentrating AFB by bleach treating sputum followed by centrifugation, significantly increases the sensitivity of direct microscopy in detecting AFB in sputum.<sup>2,3,4</sup> In a study in Zambia, centrifugation of bleach treated sputum increased the sensitivity of direct microscopy from 43.4% to 76.3%, increasing the number of smear-positive patients detected. Sensitivity is significantly increased in HIV/AIDS patients.<sup>4</sup> Details of the bleach centrifugation technique can be found in subunit 7.6. The use of bleach to liquefy (digest) the sputum reduces the risk of laboratory-acquired tuberculosis. When centrifugation is not possible, work in Ethiopia has shown that overnight sedimentation of bleach treated sputum also increases the sensitivity of smear microscopy (see reference in subunit 7.6).<sup>3</sup> Bleach treated sputum cannot be used for culture.

### **Ziehl-Neelsen staining of *M. tuberculosis***

When stained by the Ziehl-Neelsen technique, *M. tuberculosis* is acid fast and stains red. This is due to mycolic acids (fatty acids) in the cell wall which form a complex with carbol fuchsin (an arylmethane dye) and cannot be removed by the acid in the decolorizing reagent. The organisms may appear beaded. To be detected microscopically, sputum smears need to contain 5000–10 000 AFB/ml which may be found in samples from patients with cavity lesions. Young children, the elderly, and HIV infected persons (depending on the level of immunosuppression) may not produce cavities and sputum containing AFB.

*Note:* Fixing, staining, controlling and reporting Ziehl-Neelsen (Zn) stained sputum smears for AFB,



and the difference between hot and cold Zn techniques are described in subunit 7.3.5.

**Storage of Zn stained smears:** Remove the oil from the smear using a small amount of xylene or toluene. Store in a slide box or other container with a tight-fitting lid and protected from light. For quality control purposes, stained oil free smears can be mounted using a plastic polymer mountant such as *Permout*, *DPX* or *HystoMount*. When re-examining, immersion oil is placed on the cover glass.

### Detecting AFB by fluorescence microscopy

When facilities for fluorescence microscopy and staff trained in fluorescence techniques are available, sputum smears can be examined rapidly using a 40× objective (or 25× objective). This increases the possibility of finding AFB especially when they are few. Fluorochrome-stained organisms are detected by their fluorescent glow which makes them appear larger. Always include a positive control smear with each batch of fluorescence stained smears.

*Note:* Staining sputum smears by the auramine-phenol fluorescence technique is described in subunit 7.3.6.

### Culture

As previously mentioned, in most developing countries, isolation, identification and susceptibility testing of *M. tuberculosis* are usually carried out in a Reference Tuberculosis Laboratory to manage treatment failures and patients that have relapsed, to monitor multi-drug resistance, and to identify *M. tuberculosis* variants and strains, e.g. *M. bovis*, for epidemiological purposes. As more rapid and less expensive culture and other techniques are developed for detecting, identifying, and susceptibility testing of *M. tuberculosis*, it may be possible to detect tuberculosis at an earlier stage of infection when AFB are too few to be detected in direct sputum smears. Culture is considerably more sensitive than microscopy, detecting 10–100 viable organisms/ml of sputum.

#### Growth requirements

Specimens such as sputum, urine, and pus which contain commensals, require decontamination before being cultured for *M. tuberculosis*. For routine purposes, sodium hydroxide, 40 g/l has been found to be an effective decontaminant.

*M. tuberculosis* will grow aerobically on a protein-enriched medium, e.g. Lowenstein Jensen egg medium. The optimal temperature for growth is 35–37°C. The organism is slow-growing.

When cultured on Lowenstein Jensen medium at 35–37°C, *M. tuberculosis* produces raised, dry,

cream (buff) coloured colonies. Visible colonies are usually produced 2–3 weeks after incubation, but cultures should be incubated for up to 6 weeks before being discarded.

### Identification of *M. tuberculosis* cultures

The minimum investigations required to identify *M. tuberculosis* isolates are:

- *Examination of a Ziehl-Neelsen stained smear:* To confirm that the organism is acid fast. Following culture, the organisms are difficult to emulsify on a slide and are often seen lying together like pieces of string or cord. This cording is not specific to *M. tuberculosis* and may occur to a lesser degree with other *Mycobacterium* species.
- *Testing for pigment production:* This is done by leaving the culture in light for 2 hours (avoiding direct sunlight), re-incubating it at 35–37°C overnight, and then examining the colonies for the development of a yellow pigment.  
*M. tuberculosis* is a nonchromogen, i.e. it does not produce pigment in light or darkness.
- *Incubation of a subculture of the organism at 25°C:* *M. tuberculosis* will not grow at 25°C.
- *Growth on Lowenstein Jensen medium containing 500 µg/ml 4 (p)-nitrobenzoic acid:* Providing the correct size of inoculum is used, *M. tuberculosis* will not grow on 4 (p)-nitrobenzoic acid (PNB) medium.

*Note:* Details of decontamination procedures, culturing *M. tuberculosis*, tests to identify the *M. tuberculosis* complex, and antimicrobial sensitivity tests, can be found in the publication *Basic laboratory procedures in clinical Bacteriology*.<sup>1</sup>

### Antibody tests to diagnose tuberculosis

While several antibody tests are available to assist in the diagnosis of tuberculosis, evaluations in developing countries with high tuberculosis infection rates and high prevalence of HIV infection, have shown the tests to have limited value. The tests lack adequate sensitivity and specificity.

### New technologies under development to diagnose tuberculosis

In response to the urgent need for sensitive, specific, rapid, easy to perform, affordable technologies to diagnose active tuberculosis at an early stage, the Foundation for Innovative New Diagnostics (FIND)\* is collaborating with several manufacturers in the development, production, and evaluation of several new technologies appropriate for use in developing countries.

\***FIND:** Launched at the World Health Assembly in May 2003 as a non-profit Swiss foundation based in Geneva and funded by the Bill and Melinda Gates Foundation, FIND is dedicated to the development of diagnostic tests for infectious diseases for use in developing countries. See Appendix 11 for contact details.

The following are among the tuberculosis diagnostic technologies which are currently (2005) under development (and, or, refinement) and evaluation in low income countries where tuberculosis and HIV are of major public health importance:

- *FASTPlaque TB*, a bacteriophage-based assay to detect within 48 h, *M. tuberculosis* in sputum and *FASTplaque TB-RIF* to identify rifampicin resistance in *M. tuberculosis* strains. The tests are produced by Biotec Laboratories (see Appendix 11 for contact details).
- *TK Medium*, a mycobacterial solid culture medium which contains colour dye indicators to detect mycobacterial growth at an earlier stage (average 10–18 days) than other culture media. When there is mycobacterial metabolic activity, the colour of the medium changes from red to yellow. Bacterial contamination is indicated by the development of a green colour. The medium has a shelf-life of 4 months. Further details of TK medium can be obtained from the manufacturer Salubris Inc. (see Appendix 11).
- *MTB ICT Strip*, an immunochromatographic urinary antigen test based on the detection of lipoarabinomannan in urine. This tuberculosis screening test is being developed by Chemogen Inc. (see Appendix 11).
- *LAMP (loop-mediated isothermal amplification) test*, a sensitive molecular amplification technique to diagnose tuberculosis by detecting *M. tuberculosis* DNA in clinical samples. The test is being developed by Eiken Chemical Company (see Appendix 11).
- *Proteome Systems TB test*, a rapid technique to detect antigens produced in active tuberculosis and to measure severity of infection. The test is being developed by Proteome Systems (see Appendix 11).

*Note:* Further information on the validation and performance of these new technologies in developing countries can be obtained from FIND (see Appendix 11 for contact details).

### Antimicrobial susceptibility

Antimicrobial susceptibility testing is particularly required when a relapse occurs during treatment, a patient does not respond to treatment and drug resistance is suspected. Drug susceptibility testing must be accurately performed and only in a

Tuberculosis Specialist Laboratory by adequately trained staff. Antimicrobials with activity against *M. tuberculosis* include the first line drugs, isoniazid, rifampicin, pyrazinamide, ethambutol, and the second line drugs, streptomycin, capreomycin, cycloserine, thiacetazone, and ethionamide.

### WHO recommendations for chemotherapy of tuberculosis

Short course antituberculosis therapy recommended by WHO consists of an initial 2 month intensive treatment with rifampicin, isoniazid and pyrazinamide. Ethambutol or streptomycin is added if resistance to one of the former drugs is common in a given region or if twice or thrice weekly therapy is indicated. This phase is followed by a 4 month continuation phase of rifampicin and isoniazid. WHO recommends the use of directly observed therapy short course (DOTS) to ensure complete cure and prevent multi-drug resistance. Full information on treatment of patients with tuberculosis can be found in the WHO publication *TB/HIV – A Clinical Manual*.<sup>5</sup>

Drug resistance is a serious and growing problem in many developing countries where anti-tuberculosis treatment is inadequately funded and incorrectly applied, where there is poor compliance by patients and therapy is not supervised, when there is political instability with people becoming displaced by war and famine, and when drug supplies are intermittent and their quality uncontrolled. Multi-drug resistance (defined as resistance to both rifampicin and isoniazid, with or without other resistances) necessitates the use of more expensive drugs that may be less effective, more toxic, and need to be taken for longer periods of time under full supervision.

---

### Other mycobacteria that cause opportunistic pulmonary infections, disseminated disease, lymphadenitis

Environmental mycobacteria are being increasingly reported as causing opportunistic infections in those with HIV disease and other conditions associated with immunosuppression.

*Note:* Environmental mycobacteria are also referred to as atypical, ‘anonymous’ or ‘Mycobacteria other than tubercle’ (MOTT). The term environmental mycobacteria is preferred.

Chart 7.11 lists those environmental mycobacteria that are the most frequent causes of pulmonary infections resembling tuberculosis, species that cause disseminated disease and species that cause lymphadenitis (mainly in children). Such species are acid fast but differ from the *Mycobacterium tuberculosis* complex by being opportunistic pathogens, with limited distribution and acquired from the environment, e.g. soil or water, (person to person transmission rarely occurs). They can be differentiated from *M. tuberculosis* (in a Reference Laboratory) by their ability to produce pigment when cultured in darkness and light (scotochromogen), when only exposed to light (photochromogen), or non-pigment producing (nonchromogen), by their ability to grow at 25°C and in 4 (*p*)-nitrobenzoic acid (PNB) medium (see chart 7.11).

Most, similar to *M. tuberculosis*, are slow-growing (*M. chelonae* and *M. fortuitum* are rapid-growers). A range of additional tests are required to identify the different species.

Opportunistic pulmonary infections caused by environmental mycobacteria appear to be rare in developing countries.

**Chart 7.11** Principal environmental mycobacteria that cause opportunistic pulmonary infections, disseminated disease, lymphadenitis

	SI/R	25 °C	Pigment	PNB
<b>Pulmonary infections</b>				
<i>M. avium-intracellulare</i> (commonest)	SI	+	N/S	+
<i>M. kansasii</i>	SI	+	N/S	+
<i>M. xenopi</i>	SI	–	N/S	+
<i>M. malmoense</i>	SI	+	N	+
<i>M. scrofulaceum</i>	SI	+	S	+
<i>M. chelonae</i>	R	+	N	+
<i>M. fortuitum</i>	R	+	N	+
<b>Disseminated disease</b>				
<i>M. avium-intracellulare</i> , <i>M. chelonae</i>	See above			
<b>Lymphadenitis</b>				
<i>M. avium-intracellulare</i> , <i>M. scrofulaceum</i>	See above			

**Note:** *M. tuberculosis* is slow-growing, a nonchromogen, does not grow at 25 °C or in PNB medium.

**Key:** R = Rapid-growing, SI = Slow-growing, N = Non-chromogen, P = Photochromogen, S = Scotochromogen, PNB = 4(p) nitrobenzoic acid medium.

#### REFERENCES

- 1 **World Health Organization**, *Basic laboratory procedures in clinical bacteriology*, 2nd edition, 2003.
- 2 **Haleenzu C, Lubasi D, Fleming AF**. Improved sensitivity of direct microscopy for detection of acid-fast bacilli in sputum in developing countries. *Transactions Royal Society Tropical Medicine & Hygiene*, 92, pp. 415–416, 1998.
- 3 **Gebre-Selassie S**. Evaluation of the concentration sputum smear technique for the laboratory diagnosis of pulmonary tuberculosis. *Tropical Doctor*, 33, July, 2003.
- 4 **Buchfield J et al**. Sputum concentration improves diagnosis of tuberculosis in a setting with a high prevalence of HIV. *Transactions Royal Society Tropical Medicine*, 94, pp. 677–680, 2000.
- 5 **Harries A et al**. *TB/HIV – A clinical manual*. WHO, 2nd edition, 2004. Available from Tuberculosis Research and Surveillance Unit, WHO, 1211 Geneva, 27-Switzerland.

#### FURTHER INFORMATION

**WHO** *Global tuberculosis control, surveillance, planning, financing – WHO Report 2005*, World Health Organization, WHO/HTM/TB/2005.

**International Union Against Tuberculosis and Lung Disease (IUATLD)** *Technical Guide – Sputum examination for tuberculosis by direct microscopy in low income countries*, IUATLD, Paris, 5th edition, 2000.

**Yassin MA et al**. How many sputum smears are necessary for

case finding in pulmonary tuberculosis. *Tropical Medicine International Health*, 8, pp. 827–832, 2003.

**Kivihya-Ndugga LE et al**. A comprehensive comparison of Ziehl-Neelsen and fluorescence microscopy for the diagnosis of tuberculosis in a resource-poor urban setting. *Internal Journal Tuberculosis Lung Disease*, 7, pp. 1163–1171, 2003.

**McNerney R**. Workplace protection from tuberculosis. *Africa Health*, September, pp. 15–16, 2002.

**Harries A et al**. *TB/HIV A clinical manual*, WHO, 2nd edition, 2004.

**WHO** *Anti-tuberculosis drug resistance in the world – Third Global Report*. World Health Organization, Geneva, 2005.

#### WEBSITES

- WHO tuberculosis website [www.who.int/tb](http://www.who.int/tb)
- Global plan to stop TB website [www.stoptb.org](http://www.stoptb.org)
- International Union Against Tuberculosis and Lung Disease website [www.iauatl.org](http://www.iauatl.org)

## 7.18.29

## *Mycobacterium ulcerans*

#### Pathogenicity

*M. ulcerans* causes Buruli ulcer (the term *M. ulcerans* disease is preferred) in localized areas in tropical and sub-tropical regions of Africa, Southeast Asia, Latin America, Central America, and the Western Pacific. The organism is thought to live in the soil, on swamp grass and other marsh vegetation. It has been detected in swamp water and water insects. Infection probably occurs by *M. ulcerans* entering the skin through cuts, scratches, or insect wounds or by spikes on vegetation. Aquatic insects may be involved. Those mainly infected live in rural areas near rivers or wetlands. Infection is common in children under 15 years of age. In recent years the incidence of *M. ulcerans* disease has been increasing, particularly in West Africa. In Ghana up to 22% of people are infected in some villages, and in Cote d'Ivoire, prevalence rates are reported as 16%.

Infection with *M. ulcerans* begins as a subcutaneous nodule which later develops into an ulcer with a deeply undermined edge due to necrosis of subcutaneous fat. An exotoxin (mycolactone) is thought to cause the tissue necrosis. Large areas of skin and sometimes bone are destroyed and the immune system is suppressed due to toxin

production. Most lesions are on the limbs, particularly the lower limbs.

When there is immune reactivity, ulcers heal, leaving scarring, restricted movement of limbs, and often permanent deformity. Ulcers often recur. Most patients do not respond to antibiotic treatment. Surgical removal of the lesion is usually the only treatment with skin grafting when the ulceration is extensive. BCG vaccination gives variable short-term protection from the disease.

*Note:* Guidelines on the diagnosis and management of *M. ulcerans* disease can be found in the paper of Asiedu and publications, *Diagnosis of Mycobacterium ulcerans disease*, and *Management of Mycobacterium ulcerans disease* (see Further information).

#### WHO Global Buruli Ulcer Initiative (GBUI)

In response to the increasing incidence and serious public health problem from Buruli ulcer, WHO in 1998 established the *Global Buruli Ulcer Initiative* to increase awareness and raise funds for control efforts, improvements in the diagnosis, treatment, and surveillance of Buruli ulcer, and for health education, training, research into *M. ulcerans* toxin, vaccine, drug development, and environmental factors that favour emergence of the disease. Details of the GBUI 2004 Report can be found under Further information.

#### LABORATORY FEATURES

*M. ulcerans* disease is usually diagnosed clinically and by finding acid fast bacilli (AFB) in smears from infected ulcers and tissue biopsies.

*Specimen:* Organisms can be found in smears made from the base, sides and undermined edges of lesions (not from ulcer discharges). At least two smears should be collected, one for Ziehl-Neelsen staining to detect AFB and the other for Gram staining which can show whether there is secondary infection.

#### Morphology

*M. ulcerans* is a non-motile, non-sporing strongly acid fast rod, measuring 1–3 × 0.5 µm. It can be stained by the Ziehl-Neelsen technique, using the method described in subunit 7.3.5 for staining AFB in sputum.

#### Culture

*M. ulcerans* can be cultured (in a Reference Laboratory) using the same culture media used to grow *M. tuberculosis*. Growth occurs only at 30–33 °C at low oxygen tension, and within a pH range of 5.4–7.4. The organism grows very slowly,

usually requiring 6–12 weeks to produce visible colonies (pale and smooth on Lowenstein Jensen medium). *M. ulcerans* is a non-chromogen and will not grow in p-nitrobenzoic acid medium.

#### FURTHER INFORMATION

*WHO Report of the 7th WHO Advisory Group Meeting on Buruli Ulcer*, World Health Organization, Geneva, 2004.

**Buntine J et al.** *Management of Mycobacterium ulcerans disease*, WHO, 2001.

**Portaels F et al.** *Diagnosis of Mycobacterium ulcerans disease*, WHO, 2001.

**Asiedu K** *Mycobacterium ulcerans* infection: Buruli ulcer. *Africa Health*, Vol. 22, No. 3, pp. 19–21, 1999.

#### WEBSITE

WHO website on buruli ulcer [www.who.int](http://www.who.int) (use Search Facility to locate buruli ulcer).

## 7.18.30

### *Mycobacterium leprae*

*M. leprae* causes leprosy, a chronic infectious disease that affects the skin, peripheral nerves, mucosa of the upper respiratory tract and the eyes. Loss of sensation and insensitivity to pain caused by nerve damage lead to injuries from burns, ulcers, and trauma, resulting in deformities particularly of the hands and feet. *M. leprae* is mainly transmitted via the respiratory tract or skin. It is acquired through prolonged exposure with a low prevalence of clinical disease in most populations (rarely exceeds 5%). It has a long period of incubation (2–5 y) or latency.

Since 1985, the use of multi-drug therapy (MDT) has reduced the global prevalence of leprosy by 85% with leprosy eliminated as a public health problem from 98 countries. Over 1 million people however are still affected by leprosy in Africa, Asia, South America, and the Pacific with the highest number (92%) of leprosy cases and new cases being found in India (64% of prevalence), Madagascar, Nepal, Mozambique, Tanzania, Myanmar and Brazil.<sup>1</sup> Between 2–3 million people are estimated to be living with deformities due to leprosy. Rehabilitation for people disabled by leprosy will take many years.

#### Classification of leprosy

The clinical forms of leprosy and progress of the disease depend on the patient's immune response

to *M. leprae*. In the tuberculoid form there is a high level of T cell immune response whereas in the lepromatous form, cellular immune responses are poor or absent. Between these two extreme forms there is a borderline form which shows features of both tuberculoid and lepromatous leprosy.

The Ridley and Jopling classification of leprosy recognizes five forms of leprosy: tuberculoid (TT), borderline tuberculoid (BT), mid-borderline (BB), borderline lepromatous (BL) and lepromatous (LL) leprosy.

#### Clinical forms of leprosy

**Tuberculoid leprosy (TT):** T cell immune responses are good. There is usually only a single or very few well-defined skin lesions. A lesion may appear as a flattened area with raised edges or as a plaque. It is without feeling or perspiration and less pigmented (hypopigmented) than the surrounding skin. The loss of feeling is due to the invasion and destruction of nerve tissue by inflammatory cells. Affected nerves show marked thickening.

No bacteria are found in skin lesions. A few organisms can sometimes be detected in biopsy preparations after prolonged searching. A biopsy will show a cellular immune response in the form of granulomatous tissue consisting of epithelioid and giant cells with marked lymphocyte infiltration.

**Borderline leprosy (BT, BB, BL):** The degree of cellular immunity ranges from less good to poor. Skin lesions range from few in BT leprosy to several or many in BB and BL disease.

BT lesions show a moderate to marked loss of pigment, perspiration, and feeling. There is only a slight to moderate loss of feeling with BB and BL lesions.

Skin smears contain very few or no bacteria in the BT form and several to many in the BB and BL forms of the disease. Biopsies may in some cases be required to confirm the diagnosis and classification of patients with borderline leprosy, especially those at, or near, the tuberculoid end of the leprosy spectrum.

**Lepromatous leprosy (LL):** In this form of leprosy, T cell immune responses are poor or absent. Patients show widespread areas of infection. Lesions are small and many, shiny with no loss of feeling. Nodules may at the same time be present on the face and trunk. Large numbers of bacteria are found in the body. The organisms are widespread even in apparently normal skin.

Skin and nasal smears contain many bacteria. The organisms multiply mainly in macrophage cells (histiocytes) in the dermis of the skin.

Patients with lepromatous leprosy often have normocytic anaemia. Antinuclear factor and rheumatoid factor may be found in the serum, and LE cells can sometimes be detected in blood buffy coat preparations.

**Indeterminate leprosy:** In the early stages of leprosy, a small macule may form which is not sufficiently developed to be classified into one of the recognized clinical forms already described. This form of leprosy is called indeterminate (I). It

may persist for several months or years, or the lesion may heal completely. Occasionally, however, indeterminate leprosy progresses to one of the recognized clinical forms.

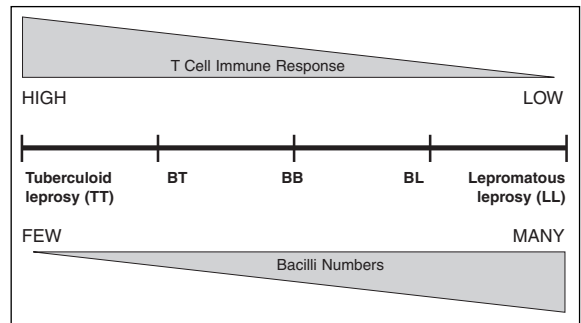

Diagrammatic representation of cellular immune responses in the different forms of leprosy.

#### Classification of leprosy for treatment purposes

For treatment purposes, leprosy is classified as either paucibacillary (PB) or multibacillary (MB) with different MDT regimens being used to treat PB and MB leprosy.

**Paucibacillary leprosy (PB):** In this form of leprosy, few or very few *M. leprae* bacilli are present in skin lesions.

Paucibacillary leprosy includes indeterminate, tuberculoid, and borderline-tuberculoid cases.

**Multibacillary leprosy (MB):** In this form of leprosy, many (multiple) bacilli are present in lesions.

Multibacillary leprosy includes mid-borderline, borderline-lepromatous, and lepromatous cases.

**Note:** Among HIV-positive MB leprosy patients, there are reports of a significant increase of type 1 reaction and neuritis.

WHO guidelines for the clinical classification of paucibacillary and multibacillary leprosy based on the number of skin lesions and nerves involved are shown in Chart 7.12. These clinical findings are used to classify leprosy for treatment regimens, particularly when reliable skin-smear services are not available. When reliable facilities for collecting and examining skin smears are available, ideally all patients should have one examination before starting MDT (see later text).

**Chart 7.12 Clinical classification of leprosy for treatment purposes**

Leprosy Group	Skin lesions*	Nerve damage**
<b>Paucibacillary leprosy (PB)</b>	<ul style="list-style-type: none"> <li>● 1–5 lesions</li> <li>● Hypopigmented or erythematous</li> <li>● Asymmetrically distributed</li> <li>● Definite loss of sensation</li> </ul>	<ul style="list-style-type: none"> <li>● Only one nerve trunk</li> </ul>
<b>Multibacillary leprosy (MB)</b>	<ul style="list-style-type: none"> <li>● More than 5 lesions</li> <li>● Distribution more symmetrical</li> <li>● Loss of sensation</li> </ul>	<ul style="list-style-type: none"> <li>● Many nerve trunks</li> </ul>

\*Skin lesions: Include macules (flat lesions), papules (raised lesions) and nodules.

\*\*Nerve damage: Resulting in loss of sensation or weakness of muscles supplied by the affected nerve.

### **ML Flow Test to assist in the classification of leprosy patients<sup>3</sup>**

A simple to perform rapid immunochromatographic test, the *ML Flow Test* has been developed to detect IgM antibodies to *M. leprae* specific phenolic glycolipid (PGL-1). These antibodies correlate with the bacterial load of a leprosy patient. The majority of paucibacillary patients are seronegative whereas the majority of multibacillary patients are seropositive. Whole blood finger prick samples can be used. The test takes 10 minutes to perform. The testing devices and running buffer can be stored at ambient temperature (up to 28 °C). The sensitivity of the *ML Flow Test* in correctly classifying MB patients has been reported as 97.4% and specificity as 90.2%.<sup>3</sup> Further details of the test can be obtained from the Royal Tropical Institute (KIT) Biomedical Research. See Appendix 11 for contact details.

## **LABORATORY FEATURES**

### **Morphology**

*M. leprae* is a non-motile, non-sporing, straight or slightly curved rod measuring  $0.2\text{--}0.5 \times 5\text{--}8 \mu\text{m}$ . Bacteria with pointed or enlarged ends are sometimes seen. The organisms can be found singly, in clusters, and in large groups within macrophage cells. Organisms in large groups are called globi. Single *M. leprae* organisms and globi are shown in colour Plate 58.

*M. leprae* is acid fast when stained by the Ziehl-Neelsen technique (see following text). It is not as

acid fast as the tubercle bacillus and therefore a weaker acid solution, i.e. 1% acid alcohol is used to decolorize smears. *M. leprae* is also less heat-resistant than tubercle organisms and therefore smears must be gently heat-fixed for just a few seconds.

### **SKIN SMEARS**

With the increasing simplification of diagnostic and treatment techniques, the role of the district laboratory in leprosy diagnosis and the follow-up care of patients has changed. Currently the diagnosis of leprosy is based on clinical signs and symptoms. Skin smears were originally used for distinguishing between paucibacillary and multibacillary leprosy, however, it is possible to classify leprosy without skin smear results and the existence of laboratory facilities should not be a pre-requisite for the implementation of MDT.<sup>2</sup> Examination of a skin smear for the presence of *M. leprae* may occasionally be needed to confirm a clinical diagnosis of multibacillary leprosy. Such a smear is simply reported as 'Positive' or 'Negative' for *M. leprae*.

*Note:* WHO advises that in view of the increasing prevalence of HIV and hepatitis B infection in many countries where leprosy remains endemic, the number of skin smears collected should be limited to the minimum necessary. Smears should be collected from only one or two sites, and only one examination should be performed before starting MDT.

### **Method of collecting and examining a skin smear for *M. leprae***

A smear for the examination of *M. leprae* must be collected by a *trained and experienced* observer using an aseptic and safe technique. The site sampled should be the edge of a leprosy lesion.

- 1 Explain the procedure to the patient (or parent if the patient is a child).

The patient should sit with his or her back to the table on which the equipment for taking the smear is placed.

- 2 Fit a new scalpel blade in its scalpel holder. Sterilize the blade by wiping it carefully with a piece of absorbent cotton wool soaked in 70% v/v ethanol (alcohol) and flaming it for 2–3 seconds in the flame of a spirit lamp. Allow the blade to cool, making sure it is not touching any unsterile surface.

- 3 Wearing protective rubber gloves, cleanse the area from where the smear is to be taken, using a cotton wool swab moistened with 70% v/v ethanol (alcohol). Allow the area to dry.
- 4 Pinch the skin tightly between the thumb and index finger until it becomes pale due to loss of blood.  
*Important:* The area must be kept bloodless while the smear is collected because a smear which contains red cells will be difficult to examine and report.
- 5 Using the sterile blade, make a small cut through the skin surface, about 5 mm long and deep enough into the dermis (2–3 mm) where the bacteria will be found. Continue to hold the skin tightly.
- 6 Using a dry piece of cotton wool, blot away any blood which appears at the site of the cut.  
*Note:* Providing the pressure is maintained between the thumb and index finger, little or no bleeding should occur.
- 7 Turn the scalpel blade until it is at a right angle to the cut. Using the *blunt* edge of the blade, scrape firmly two or three times along the edges and bottom of the cut to collect a sample of tissue juice and cells.
- 8 Transfer the sample to a slide. Make a small circular smear, covering *evenly* an area measuring 5–7 mm in diameter.
- 9 Cover the cut with a small dressing. Instruct the patient to remove the dressing as soon as the cut has healed.
- 10 Ensure the slide is clearly labelled with the patient's name and identification number.
- 11 When the smear has dried, *gently* heat-fix it by holding it, smear uppermost, over the flame of a spirit lamp or the pilot flame of a Bunsen burner for a *few* seconds. *Do not* over-heat because this will interfere with the staining of *M. leprae*.

### Ziehl-Neelsen technique for staining

#### *M. leprae*

##### Required

- |                                   |                |
|-----------------------------------|----------------|
| – Carbol fuchsin stain (filtered) | Reagent No. 21 |
| – 1% v/v acid alcohol             | Reagent No. 3  |

- |   |                |
|---|----------------|
| – Malachite green, 5 g/l<br>(0.5% w/v)* | Reagent No. 55 |
|---|----------------|

\*If preferred, methylene blue, 5 g/l may be used instead of malachite green.

##### Method

- 1 Cover the smear with filtered carbol fuchsin stain. Heat the stain until vapour just begins to rise (i.e. about 60 °C). *Do not overheat*. Allow the heated stain to remain on the slide for 10–15 minutes (ensure the stain does not dry on the smear).
- 2 Wash off the stain with clean water. When the tap water is not clean, wash the smear with filtered tap water or clean boiled filtered rain water.
- 3 Decolorize the smear rapidly (about 5 seconds) by rinsing it with 1% v/v acid alcohol.  
*Caution:* Acid alcohol is flammable, therefore use it with care well away from an open flame.
- 4 Wash well with clean water. Cover the smear with malachite green stain (or methylene blue) for 1–2 minutes.
- 5 Wash off the stain with clean water. Wipe the back of the slide clean and place it in a draining rack for the smear to air-dry (do *not* blot-dry). Protect it from direct sunlight.
- 6 Examine the smear microscopically, first with the 40× objective to see the distribution of material and then with the oil immersion lens to look for acid fast bacilli.

##### Results

*M. leprae* . . . . . Red solid bacilli or beaded forms, occurring singly or in masses (globi)

Macrophage cells . . . . . Green\*

Background material . . . . . Green\*

\*Blue if methylene blue counterstain has been used.

*Note:* The appearance of *M. leprae* in a Ziehl-Neelsen stained smear is shown in colour Plate 58.

##### Reporting *M. leprae* smear

Report the smear as '*Positive*' if *M. leprae* bacteria are seen or '*Negative*' if no bacteria are seen after

examining the entire smear or at least 100 high power microscope fields.

**B1 and M1:** Reporting the bacterial index (B1) and morphological index (M1) is no longer required for routine purposes.

### Quality control (QC) of skin smears

To collect and report smears for *M. leprae* reliably, laboratory staff must receive adequate training and supervision. QC must include the laboratory supervisor spot-checking smear reporting (same day as smears are stained to prevent discrepancies due to fading of the stain). A control known positive smear must be used to check the staining reaction of every newly prepared batch of carbol fuchsin. Fixed smears for control purposes should be stored in an airtight light-proof box.

### Biopsies

Examination of a biopsy does not form part of the routine day to day work of leprosy control but may occasionally be required to diagnose a patient with tuberculoid leprosy or borderline-tuberculoid leprosy. A pathologist or other person with experience in examining leprosy biopsy sections (in the Central Hospital or Centre with specialist facilities), will be able to interpret a cellular response and invasion of nerve tissue by inflammatory cells.

### Multidrug therapy (MDT)

Drugs with activity against *M. leprae* that are used in the treatment of leprosy include dapsone (4.4 diaminodiphenylsulphone, or DDS), rifampicin, and clofazimine. To prevent the development of dapsone resistance, a combination of drugs is used. Multiple drug therapy (MDT) causes very few side effects, and there are few relapses. A 'one-time' single dose treatment of rifampicin, ofloxacin and minocycline (ROM) is used for patients with a single skin lesion.

*Note:* WHO recommended MDT regimens can be found in the 21st edition (2003) *Mansons Tropical Diseases* and from the websites listed under Further information.

### REFERENCES

- 1 **Lockwood NJ.** Leprosy – a changing picture but a continuing challenge. *Tropical Doctor*, April, pp. 65–67, 2005.
- 2 **WHO Expert Committee on Leprosy (Seventh Report).** WHO Technical Report series, No 874, 1998.
- 3 **Bühner-Sekula S et al.** Simple and fast lateral flow test for classification of leprosy patients and identification of contacts with high risk of developing leprosy. *Journal Clinical Microbiology*, Vol. 41, No. 5, pp. 1991–1995, 2003.

### FURTHER INFORMATION

**ILEP.** *Learning Guide 2: How to recognize and manage leprosy reactions*, International Federation of Anti-Leprosy Associations (ILEP), 2002. (Free of charge from ILEP, e-mail books@ilep.org.uk).

**Srinivasan H.** *Prevention of disabilities in patients with leprosy. A practical guide.* WHO, 1993. Available from WHO Publications, WHO, 1211 Geneva, 27-Switzerland.

**McDougall AC and Yuasa Y.** *A new atlas of leprosy*, 2000. Sasakawa Memorial Health Foundation, e-mail: sasakawa@blue.ocn.ne.jp or Fax +81 3 35082204.

### WEBSITES

- International Federation of Anti-Leprosy Associations (ILEP) www.ilep.org.uk
- WHO Leprosy website www.who.int (use Search Facility).

## 7.18.31 Actinomycetes: *Nocardia*, *Actinomadura*, *Streptomyces*, *Actinomyces*

Actinomycetes is the name given to a large group of Gram positive bacteria which form branching filaments (like fungi), chains, or fragmented forms resembling diphtheroids.

**Growth requirements:** *Nocardia*, *Actinomadura* and *Streptomyces* species are aerobes. *Actinomyces* species are facultative anaerobes which require carbon dioxide for growth.

**Granule production:** *Actinomadura*, *Streptomyces* and *Actinomyces* species produce granules (colonies of organisms) which can be found in discharges and often help in identification.

**Acid fast:** *Actinomyces* and *Nocardia* species are weakly acid fast (using Ziehl-Neelsen technique with 1% v/v acid decoloriser as described in subunit 7.18.30).

### *Nocardia* species

#### Pathogenicity

*Nocardia* species can be found as saprophytes in the soil. Infection occurs by inhaling spores. The main species of medical importance are:

- *N. brasiliensis* which causes mycetoma (described in subunit 7.18.41) and occasionally pulmonary and lymphocutaneous infection.
- *N. asteroides* which causes pulmonary disease (especially in immunosuppressed patients) and occasionally brain abscesses. Other *Nocardia* species such as *N. caviae* can also cause pulmonary infection.

**Specimens:** Depending on the site of infection, specimens include pus, sputum, and infected tissue for microscopy and culture. The collection of pus from a mycetoma is described in subunit 7.18.41.

#### Morphology

*Nocardia* species are non-motile, non-sporing, inter-



twining and branching threads which are easily fragmented (see colour Plate 59). They are Gram positive but often stain unevenly. When stained by the Ziehl-Neelsen method used to stain *M. leprae* (see subunit 7.18.30), the branches usually appear acid fast.

In mycetoma, very small soft white-yellow granules are discharged in the pus. They are best detected using a magnifying lens.

### Culture

*Nocardia* species are aerobes. They will grow at 45 °C as well as at 35–37 °C and room temperature. If cultures are first incubated at 45 °C, this will help to isolate *Nocardia* from specimens that contain commensals and secondary organisms. *Nocardia* can also be recovered from sputum treated (decontaminated) with sodium hydroxide.

When cultured on Sabouraud agar at 35–37 °C for 3–14 days, *Nocardia* species produce orange to pink, waxy folded colonies covered with white aerial hyphae. They are catalase positive and both *N. asteroides* and *N. brasiliensis* are urease positive. The organisms are Gram positive and unlike tubercle bacilli, they are only weakly acid fast (see previous text). Most strains produce *beta*-lactamase.

---

### *Actinomadura* species

#### Pathogenicity

The main species of medical importance are *A. madurae* and *A. pelletieri* which cause mycetoma (described in subunit 7.18.41).

*Specimens*: Pus from draining sinuses, collected as described in subunit 7.18.41.

#### Morphology

*Actinomadura* species are non-motile and non-sporing. Like other actinomycetes, they are Gram positive and in smears they appear as branching intertwining threads. They are not acid fast.

The granules produced by *A. madurae* are white-yellow or pink, soft, and usually about 2 mm in diameter. Crushed granules show clubs (surrounding the colony) that stain pink with eosin. The granules of *A. pelletieri* are dark red, firm and small, measuring about 0.5 mm in diameter.

#### Culture

*Actinomadura* species grow slowly and often require an enriched medium. Colonies have a leathery appearance and show red pigmentation. They do not produce urease. Both *A. madurae* and *A. pel-*

*letieri* hydrolyze casein. *Beta*-lactamase is produced by some strains.

---

### *Streptomyces somaliensis*

#### Pathogenicity

*Streptomyces* species are saprophytic organisms. The main species of medical importance is *S. somaliensis* which causes mycetoma in Somalia, Ethiopia, Sudan, Egypt, West Africa and Brazil.

*Specimens*: Pus from draining mycetoma sinuses (see subunit 7.18.41).

#### Morphology

Like other actinomycetes, *S. somaliensis* is non-motile. In smears, the organisms appear as branching intertwining Gram positive threads. The branches are not acid fast, but the spores which form in cultures are usually acid fast. In mycetoma, white-yellow hard granules about 1–2 mm in diameter are discharged in the pus.

#### Culture

*Streptomyces* grow easily on Sabouraud agar at room temperature or 35–37 °C. The colonies are cream or brown and have aerial hyphae, giving them a heaped appearance. *S. somaliensis* does not produce urease. It hydrolyzes casein.

*Beta*-lactamase is produced by up to 75% of *Streptomyces* strains. Few antimicrobials are effective against *S. somaliensis* (surgical treatment is often necessary).

---

### *Actinomyces israelii*

#### Pathogenicity

*Actinomyces* species form part of the normal microbial flora of the mouth and female genital tract, and can also be found in the soil. The main species of medical importance is *A. israelii* which cause actinomycosis, a chronic granulomatous infection in which pus containing granules (sulphur granules) is discharged through sinuses which open on the surface of the skin. The jaw is the usual site of infection, often following the extraction of a tooth, but actinomycosis of the abdomen and very occasionally of the brain and lungs, can also occur.

*Specimens*: Depending on the site of infection, specimens include pus, sputum or infected tissue.

#### Morphology

*Actinomyces* species are non-motile and non-

sporing. They are Gram positive and morphologically resemble other actinomycetes. The thin branches are easily fragmented. In Ziehl-Neelsen stained smears of crushed granules, the branches are not acid fast, but the club-shaped forms that surround the colony are acid fast. In Gram stained smears, the clubs are Gram negative. If granules are not present, examine a smear of the pus for branching forms and coccobacilli. Other anaerobic organisms may also be present.

*Actinomyces* granules are usually yellow, but they can also be brown. They are firm, round and measure 0.5–5 µm in diameter.

### Culture

*A. israelii* is anaerobic and microaerophilic. It can be isolated by culturing granules on blood agar after washing them free of pus and crushing them in a small amount of sterile distilled water. *A. israelii* is slow-growing, producing growth on blood agar after 5–7 days incubation at 35–37°C. The colonies are small, cream or white, with a rough nodular surface. They glisten and adhere to the medium.

*A. israelii* is catalase and indole negative. It does not produce urease or reduce nitrates. It hydrolyzes aesculin and ferments glucose, lactose, mannitol, and several other sugars. Isolates should be sent to a Reference Laboratory for full identification.

FURTHER INFORMATION on MYCETOMA  
This can be obtained from the mycetoma website  
[www.mycetoma.org](http://www.mycetoma.org)

## 7.18.32 *Treponema pallidum*

### Diseases caused by *Treponema*

- *Treponema pallidum* subspecies (subsp) *pallidum*\* causes syphilis.
- *Treponema pallidum* subsp. *pertenue*\* causes yaws, see end of subunit.
- *Treponema pallidum* subsp. *endemicum*\* causes endemic syphilis (bejel), see end of subunit.
- *Treponema carateum* causes pinta, see end of subunit.

\*Referred to simply as *T. pallidum*, *T. pertenu*, *T. endemicum*.

### Pathogenicity

*T. pallidum* causes:

- Sexually acquired syphilis which has an early infectious stage occurring within the first 2 years of infection, and a late non-infectious stage.

*Early stage*: Includes primary syphilis, secondary syphilis and early latent syphilis.

*Late stage*: Includes late latent syphilis, benign late syphilis, cardiovascular syphilis, and neurosyphilis.

### Primary syphilis

Within about 3 weeks of infection an ulcer, known as a chancre forms at the site of infection usually on the genital area (about 10% of ulcers are extragenital). The ulcer is shallow, well-defined with indurated edges and a smooth red surface that exudes serum. It is usually painless. Treponemes can be found in the chancre fluid. There is enlargement of nearby lymph nodes. The chancre heals after 3–6 weeks. Healing may be delayed in those co-infected with HIV.

### Secondary syphilis

This occurs 4–8 weeks after the primary infection. A widespread non-itchy maculopapular rash appears, corresponding to the spread of organisms in the body. The secondary skin lesions contain treponemes and are highly infectious. Treponemes are also present in the blood. Mucous membranes are also infected and mouth ulcers are common. There is generalized enlargement of lymph nodes, headache, joint pains, fever, malaise and other symptoms. In those co-infected with HIV, the syphilitic rash may be severe with ulceration. In most patients the secondary lesions heal although relapses can occur.

### Latent syphilis

During the latent stage, there are no clinical manifestations of syphilis but there is serological evidence of infection. Latent syphilis is described as early when the infection is under 2 years or late latent syphilis when the infection is more than 2 years.

### Late stage syphilis

About 30% of patients with untreated latent syphilis progress to late syphilis, a slowly progressive inflammatory stage in which granulomatous lesions (gummas) develop in skin, bones, liver, stomach and other organs, and degenerative changes occur in the central nervous system causing meningovascular syphilis, and general paralysis with cerebral atrophy, psychosis and dementia. Cardiovascular syphilis may lead to aortic aneurysm and aortic valve insufficiency. Treponemes are not present in late stage syphilitic lesions. In those co-infected with HIV, late stage syphilis may progress more rapidly with neurosyphilis developing early.

- Congenitally acquired syphilis in which a mother with infectious syphilis infects her unborn infant. Treponemes in the blood pass through the placenta. Syphilis in pregnancy can lead to abortion, premature delivery, stillbirth, perinatal death and the birth of infants with congenital syphilis.

### Congenital syphilis

Infants born with congenital syphilis, depending on the severity of infection, have a rash, skin and mucous membrane lesions and often fail to gain weight, becoming marasmic. There is usually a high mortality rate. Infected infants are often born with bone defects, joint swellings, and hepatosplenomegaly. Difficulties in hearing and sight problems may develop at a later stage. Other organs may also be affected.

*Note:* Further information on congenital syphilis can be found in the 2004 June 82(6) issue of *Bulletin World Health Organization* (available on website [www.who.int/bulletin](http://www.who.int/bulletin)).

The World Health Organization estimates that there are about 12 million new cases of syphilis worldwide each year. Many of these occur in developing countries. Infection rates are high among sex workers and long distance truck drivers. Syphilis (and other sexually transmitted diseases that cause genital ulceration) increase susceptibility to infection with HIV. In those co-infected with *T. pallidum* and HIV, syphilis may be more aggressive and progress more quickly, relapses are more common and serological reactions may be altered (see later text).

### LABORATORY FEATURES

*Specimens:* Serous fluid from chancres and secondary skin lesions (from moist areas) to detect motile treponemes.

*T. pallidum* spirochaetes can be detected during primary and secondary syphilis, infectious relapsing syphilis and early congenital syphilis.

*Note:* Within a few hours of antibiotic treatment, spirochaetes will not be found in lesions. Sometimes the organisms can be detected in lymph gland fluid. It is important therefore to ask patients whether they have taken antibiotics to treat their infection. When a specimen is collected at the healing stage of the chancre, the organisms may be too few to detect by dark-field microscopy. Blood should always be collected for antibody testing when syphilis is suspected but no treponemes are detected microscopically.

A blood sample (3–5 ml) is required for serological testing. The serum/plasma obtained must not be haemolyzed, lipaemic, or contaminated.

*Caution:* *T. pallidum* is highly infectious, therefore wear protective gloves when collecting chancre fluid and blood, and ensure preparations are disposed of safely.

### Morphology

*T. pallidum* is a thin, delicate, tightly wound spirochaete (treponeme), 6–15 µm long with 8–14 evenly sized coils. *T. pallidum* cannot be seen in Gram stained smears. The organisms are best seen by dark-field microscopy in serous fluid collected from a primary chancre or secondary skin lesion (about 50–80% sensitive). The collection and examination of serous fluid to detect *T. pallidum* are

described in subunit 7.10. The organisms have a bending and slowly rotating motility and may be seen lengthening and shortening. A dark-field preparation of *T. pallidum* is shown in colour Plate 60. The spirochaetes can also be demonstrated by immunofluorescence but this requires specialized equipment and expensive reagents.

### Commensal genital spirochaetes

These may occasionally contaminate serous fluid. They are, however, of variable size, thicker than *T. pallidum*, have fewer coils and a different motility. Immunofluorescence tests differentiate between pathogenic and commensal treponemes.

### Culture

Pathogenic treponemes have not yet been reproducibly cultured in the routine laboratory. The organisms, however, are able to survive in some fluids, including donated blood.

### Avoiding transmission of *T. pallidum* in blood

The transmission of *T. pallidum* by blood transfusion can be avoided by storing all donor blood at 2–6°C for 3–5 days and collecting blood from low risk donors (see subunit 9.3) or preferably from donors previously serologically screened for syphilis. A rapid immunochromatographic test can also help detect infected blood.

### Serological diagnosis of syphilis

While the detection of treponemes by dark-field microscopy is the simplest and most rapid method of diagnosing syphilis, the organisms cannot be found when skin lesions have healed. Testing a patient's serum for antibodies then becomes the main way of making a presumptive diagnosis of syphilis. Some tests can also be used to monitor response to treatment.

A person infected with *T. pallidum* produces two types of antibody:

- Non-specific antibody that reacts with cardiolipin antigen in non-specific syphilis tests.

#### Cardiolipin

This is a phospholipid substance extracted from beef heart tissue. To make cardiolipin antigen, the extracted cardiolipin is complexed with cholesterol and lecithin (to produce standard reactivity in tests). It is thought that a similar substance to cardiolipin is released from tissue damaged by treponemal infection and possibly also from the treponemes, and this substance (often referred to as reagin) stimulates the production of anti-cardiolipin antibodies which can be detected in the serum of patients.

- Specific treponemal antibody that reacts with treponemal antigen in specific syphilis tests.

*Note:* The serological diagnosis of syphilis (as also the microscopical diagnosis) is unable to differentiate between infection with *T. pallidum*, *T. pertenuis*,

*T. endemicum* and *T. carateum*. Ways of differentiating syphilis from yaws, bejel and pinta are described at the end of this subunit.

#### NON-SPECIFIC CARDIOLIPIN (REAGIN) TESTS

Non-specific tests include:

- VDRL (Venereal Diseases Research Laboratory) test which is read microscopically.
- RPR (Rapid plasma reagin) test which is read macroscopically.

Less widely used non-specific cardiolipin tests include the USR (Unheated serum reagin test), RST (Reagin screen test) and TRUST (toluidine red unheated serum test).

#### VDRL

In the VDRL test, heat-inactivated serum (to destroy complement) is reacted with freshly prepared cardiolipin-cholesterol-lecithin antigen and the resulting flocculation (suspended antigen-antibody complex) is read microscopically using a 10X objective and 10X eyepiece. Reactive tests are quantitated to obtain the antibody titre (using a double dilution technique).

#### RPR

In the RPR test, the cardiolipin-cholesterol-lecithin antigen has choline chloride added to it which removes the need for heat-inactivation of samples and enables plasma as well as serum to be used in the test. It also enhances the reactivity of the antigen.

The antigen is supplied in a ready-to-use stabilized form which can be kept for up to 6 months when stored at 4–10°C. Carbon is also added to the antigen, enabling test reactivities to be read macroscopically (carbon particles become trapped in the floccules). In the RPR test, the patient's serum or plasma is spread within a marked circular area on a plastic coated card, antigen is added, and the mixture rotated at 100 rpm for 8 minutes using a mechanical rotator. Reactive tests are quantitated to obtain the antibody titre.

#### Availability of VDRL and RPR tests and rotators

The tests are widely available although prices vary considerably between manufacturers and suppliers. Suppliers include those listed in Chart 7.2 in subunit 7.2 on p. 16.

**Rotators:** A mains-battery operated rotator suitable for use with the RPR test is available from Developing Health Technology (*Immutrep Rotator*). It is described and illustrated on pp. 158–159 in Part 1 of the book. Contact details for Developing Health Technology can be found in Appendix 11.

#### **Interpretation of non-specific cardiolipin test results**

Non-specific anti-cardiolipin antibodies are produced about 3–5 weeks following infection (about 2 weeks after the chancre forms). Large amounts of antibody are produced in secondary syphilis (100% reactivity). In latent and late syphilis, anti-cardiolipin antibodies decline (even without treatment) and tests often become non-reactive or weakly reactive. Following successful treatment, anti-cardiolipin antibody titres fall, becoming negative after about 6 months in primary syphilis and after 12–18 months in secondary syphilis. False reactions and difficulties in the interpretation of cardiolipin tests for syphilis are due to:

- Biological false positives, reducing the specificity of tests.
- Prozone reactions.
- Tests being performed incorrectly.
- Co-infection with HIV, producing abnormal reactions.

#### *Biological false positives*

Besides treponemal infection, anti-cardiolipin antibodies may also be produced, usually in low titres (1 in 8 or below) in other infections, immune disorders, and narcotic drug abuse, giving rise to biological false positive (BFP) results. Transient BFP, (less than 6 months duration) can occur with infective hepatitis, virus pneumonia, chickenpox, measles, lymphogranuloma venereum, acute malaria, trypanosomiasis, following immunization, and during pregnancy. Long-term (chronic) BFP, can occur in systemic lupus erythematosus, rheumatoid arthritis, lepromatous leprosy, tuberculosis, malignancy, and narcotic addiction.

Because cardiolipin tests are not specific for treponemal infections, a reactive non-specific test should be checked using a specific treponemal test. When the specific test is non-reactive and the antibody titre (non-specific test) is 1 in 8 or below, a BFP is indicated. When the titre is greater than 1 in 8, both the non-specific test and specific test should be repeated at a later stage to look for a rising titre.

#### *Prozone reaction*

A prozone reaction can occur when the anti-cardiolipin antibody titre is very high, e.g. in secondary syphilis. Excess antibody prevents normal antibody-antigen reactivity, which may result in a test being falsely reported as 'non-reactive'. With experience, most prozone reactions can be recognized by their 'roughness' or abnormal grainy appearance,

however, initial testing of sera undiluted and diluted 1 in 20 will pick up any prozone reaction.

#### *Incorrect performance of test*

The manufacturer's instructions for performing qualitative and quantitative tests must be followed exactly, including the use of controls. Specimens and reagents must be at the correct temperature for testing. Reactivity is decreased at temperatures below 23 °C and increased at temperatures over 29 °C. Other sources of error include the use of contaminated reagents, testing samples that are haemolyzed, lipaemic or contaminated, adding an incorrect volume of antigen, or rotating tests at an incorrect speed or for an incorrect length of time. Known positive and negative controls should be included with each batch of tests.

#### *Abnormal reactions due to HIV infection*

In HIV disease, immunosuppression can result in a poor antibody response in syphilis with tests being non-reactive. Occasionally, infection with HIV can produce high antibody titres and prozone reactions due to B cell activation. Co-infection with HIV is also associated with the failure of antibody titres to fall after treatment. Neurosyphilis may occur early in the disease. Skin lesions suspected of being syphilitic should be examined for motile treponemes.

#### **SPECIFIC TREPONEMAL TESTS**

A specific treponemal test is performed when a person gives a reactive non-specific cardiolipin test or in late stage syphilis when a cardiolipin test may be non-reactive. Unlike cardiolipin antibody tests, specific treponemal tests do not produce BFP, however cross-reactions can occur giving rise to false positive test results. Because *T. pallidum* IgG antibody can persist in the serum for long periods, specific tests can remain positive for many years, even after successful treatment.

Specific treponemal tests include:

- TPHA (*T. pallidum* haemagglutination assay)
- TPPA (*T. pallidum* particle agglutination assay)
- FTA-ABS (Fluorescent treponemal antibody absorption) test
- Rapid immunochromatographic tests

#### **TPHA**

The IgM binding capacity of TPHA reagents varies and reactions can be detected around the fourth week but may take longer. Titres tend to be low in

primary syphilis (80–320) but rise sharply in the secondary stage (5120 or greater). Although a drop in antibody titre occurs in latent and late syphilis, a positive TPHA test may still be found 20–30 years after treatment. A positive TPHA indicates either present or past infection.

In the TPHA, patient's diluted serum samples are mixed in the wells of a microtitration plate with sheep or avian red cells coated (sensitized) with *T. pallidum* antigen (Nichol's strain). If antibody is present the sensitized cells are agglutinated and they settle in a characteristic mat pattern in the bottom of the well. Unagglutinated cells in a negative test form a button or smooth ring at the bottom of the well.

Non-specific cross-reacting antibodies which may be in the patient's serum due to the presence of commensal treponemes, are removed by an extract (from the non-pathogenic Reiter's treponeme) contained in the diluent used in the test. False positive reactions can occur in connective tissue disorders and lepromatous leprosy. There are several manufacturers and suppliers of TPHA tests including Oxoid, Plasmatec, Tulip Group, and Mast Group (for contact details, see Appendix 11).

#### **TPPA**

The TPPA test is similar to the TPHA test except that gelatin particles instead of red cells are sensitized with *T. pallidum* antigen, making the reagent more stable. A positive test is indicated by clumps of particles. A useful modification of the test has been described by Coates *et al*<sup>1</sup> in which capillary blood (e.g. from antenatal patients) is collected onto absorbent card, dried, and tested at a later stage for antibody following a simple elution technique. The modified blot spot TPPA not only avoids the need to collect venous blood but also reduces the price per test because the antigen reagent is diluted 1 in 10 when used in the modified test. The TPPA test is manufactured by Fujirebio. For details of local availability and prices contact the manufacturer (see Appendix 11).

#### **FTA-ABS**

The fluorescent antibody test is the first serological test to become positive following infection, i.e. 3–4 weeks after infection. It is an expensive test mainly performed in reference public health laboratories.

#### *Rapid immunochromatographic syphilis tests*

Several rapid, simple to perform and read immunochromatographic tests in cassette form

(lateral flow) have been developed to assist in the diagnosis of syphilis and screening of donor blood. The tests use *T. pallidum* recombinant antigens and provide results similar to those of specific treponemal tests, i.e. a positive test may indicate present or past infection. The use of a non-specific test such as the RPR is required to determine active infection. Immunochromatographic tests which are the most useful are those that can be transported and stored at ambient temperature (up to 30 °C). Examples include *Syphicheck-WB*, *Visitect Syphilis*, *SD Bioline Syphilis* and *Determine Syphilis TP*. With *Syphicheck-WB* and *Visitect Syphilis*, test kits include all the items needed to perform the test (individually packaged testing cassettes, diluent buffer, sample dropper).

*Syphicheck-WB* and *Visitect Syphilis* are performed by adding 1 drop sample to the sample well, followed by 2 drops diluent buffer. Test results are read after 15 minutes. A positive test is shown by a pink-mauve line in both the control and test areas as shown in Fig. 7.31 and Colour Plate 62. A negative test is shown by a pink line in the control area only.

**Availability:** *Syphicheck-WB* is manufactured by Qualpro Diagnostics (Tulip Group) and *Visitect Syphilis* is available

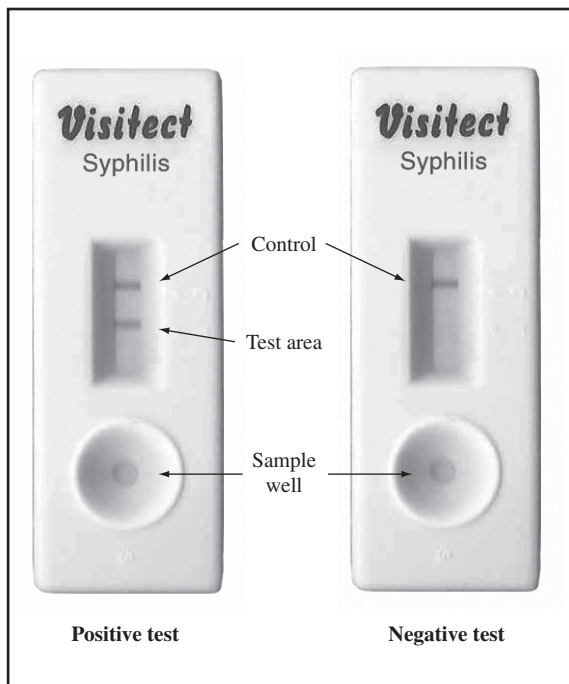

Fig. 7.31 *Visitect Syphilis* test results. A positive result is shown by a pink line in the Test and Control areas. A negative result is shown by a pink line in the Control area only. Courtesy *Omega Diagnostics*.

from Omega Diagnostics. See Appendix 11 for contact details.

In 2003, the WHO *Sexually Transmitted Diagnostics Initiative* (SDI) published the results of evaluations carried out in eight laboratories (in Africa, Asia, Americas, Europe) on six rapid syphilis diagnostics, including the previously mentioned tests.<sup>2</sup> The tests showed a good overall performance compared with the reference standard tests of TPHA or TPPA. Using serum samples, sensitivity ranged from 85–98% and specificity from 93–98%. Further evaluations in field situations are underway to assess their usefulness in screening pregnant women, performance characteristics when using whole blood and their effectiveness in the control of syphilis.

### Testing cerebrospinal fluid to investigate neurosyphilis

Although syphilitic meningitis may develop during secondary syphilis, neurosyphilis usually occurs as a complication of late syphilis. A person with neurosyphilis will have a reactive specific treponemal serological test and therefore serum should always be tested before collecting cerebrospinal fluid (c.s.f.). Serum cardiolipin tests may be reactive or non-reactive. Neurosyphilis is extremely unlikely at serum TPHA titres below 640.

*Note:* Contamination of the c.s.f. with even a small amount of blood can yield misleading results.

*Testing c.s.f. (providing serum specific antibody test is positive)*

The following c.s.f. tests are helpful in diagnosing neurosyphilis:

- VDRL test using unheated c.s.f. The c.s.f. VDRL test is reactive in about 50% of patients with neurosyphilis. When the c.s.f. VDRL test is non-reactive, perform a c.s.f. TPHA. If this test is non-reactive, neurosyphilis can be excluded. A reactive TPHA, in the absence of any red cells in the c.s.f. along with a raised cell count and raised protein is strongly suggestive of neurosyphilis.
- Cell count (see subunit 7.13). More than 5 cells  $\times 10^6/l$  (lymphocytes) will be found.
- Total protein. The total c.s.f. protein will be in excess of 0.4 g/l (40 mg%).

*Note:* Following successful treatment, the c.s.f. cell count should return to normal, followed by the total protein. The c.s.f. VDRL may take a long time to become non-reactive but it should be possible to observe a gradual decrease in reactivity.

**Chart 7.13 Main differences between non-specific and specific syphilis antibody tests****Non-specific cardiolipin tests**

*Examples:* VDRL, RPR

- Screening tests.
- Indicate possible active disease.
- Antibody titre falls with effective treatment.
- Tests may become non-reactive in late syphilis.
- Biological false positives occur (titre usually 1 in 8 or below).
- Prozone reactions can cause reactive sera to be missed.
- Rotator required for RPR test (100 rpm for 8 minutes).

**Specific treponemal tests**

*Examples:* TPHA, TPPA, FTA-ABS, rapid immunochromatographic tests

- Positive test indicates present or past infection.
- Higher specificity than cardiolipin tests.
- Used to check positive cardiolipin test reaction.
- Not suitable for assessing response to treatment.
- Tests often remain positive for many years due to persistence of IgG.
- More complex tests can be used to differentiate IgM and IgG.
- Several newly developed tests are rapid and easy to perform, e.g. immunochromatographic tests.
- TPPA test can be modified to use whole blood collected on card.

**Serological response at different stages of syphilis****Primary syphilis**

Antibodies appear 1–4 weeks after chancre. FTA-ABS detects antibodies first, followed about 1 week later by other treponemal specific tests and cardiolipin tests.

*Note:* Primary and secondary syphilis can be diagnosed microscopically (50–80% sensitive).

**Secondary syphilis**

All serological tests are positive.

**Latent syphilis**

With progressing latency, reactivity of cardiolipin tests decreases. No decrease in titre in a clinically well person, may indicate asymptomatic neurosyphilis.

**Late syphilis**

Cardiolipin tests can be reactive, weakly reactive, or non-reactive. Specific treponemal tests remain reactive (often for many years) although titres usually decrease.

**Pregnancy:** In most developing countries, a cardiolipin test is used to screen women for syphilis during pregnancy. A positive test should be checked using an IC test when available.

**To evaluate treatment:** Use quantitative cardiolipin tests (3 monthly intervals). When there is relapse (or re-infection) there is usually a rise in titre (also seen in TPHA test).

*Note:* In HIV disease, serological responses may be altered (see text).

### Congenital syphilis

In infants born with congenital syphilis it may be possible to detect motile treponemes (by dark-field microscopy) in fluid from skin lesions or nasal discharge (sufficiently thin preparation). A presumptive diagnosis of congenital syphilis can be made if an infant is born with symptoms of infection (see previous text), the mother has untreated syphilis at the time of delivery and the infant's serum gives a reactive specific treponemal antibody test at 3 months. Most of the antibody found in an infant's serum at birth will be maternal IgG. In an uninfected infant this will disappear in 2–3 months. Testing both infant and maternal sera can be helpful. Infection in the infant is indicated when the infant's antibody titre is higher than that of the mother and the titre is shown to rise. Testing for IgM treponemal antibody is not sufficiently reliable to diagnose congenital syphilis.

#### REFERENCES

- 1 **Coates GL et al.** Evaluation of the sensitivity and specificity of a *Treponema pallidum* dried blood spot technique for use in the detection of syphilis. *Transactions Royal Society Tropical Medicine*, 92, p. 44, 1998.
- 2 Sexually Transmitted Diseases Diagnostics Initiative (SDI). *Laboratory-based evaluation of rapid diagnostics*. SDI, WHO, 2003. Website [www.int/std\\_diagnostics](http://www.int/std_diagnostics)

#### FURTHER INFORMATION

See Reference 2.

**Van Dyck E, Meheus AZ, Piot P.** *Laboratory diagnosis of sexually transmitted diseases*. WHO, 1999. ISBN 92 4 154501 1. Available from WHO Publications, 1211 Geneva, 27-Switzerland.

#### WEBSITES

- WHO rapid diagnostics website [www.rapid-diagnostics.org](http://www.rapid-diagnostics.org)
- Sexually Transmitted Diseases Diagnostics Initiative website [www.int/std\\_diagnostics](http://www.int/std_diagnostics)

*Note:* For information on the bulk purchase of syphilis tests using WHO bulk procurement scheme, readers should e-mail [peeling@who.int](mailto:peeling@who.int), phone +41 22 791 3742 or fax +41 22 791 4854.

### *T. pertenue*, *T. endemicum*, *T. carateum*

*T. pertenue* causes yaws. Infection with *T. endemicum* causes endemic syphilis (bejel). *T. carateum* causes pinta. Unlike *T. pallidum*, these organisms are not transmitted sexually. In dark-field microscopic preparations, the treponemes of *T. pertenue*, *T. endemicum*, and *T. carateum* cannot be distinguished from *T. pallidum*. The non-specific and specific serological tests used in syphilis diagnosis are also positive in yaws, bejel, and pinta. Differentiation between the diseases is mainly based on the clinical appearance of lesions and areas of the body infected, differences in trans-

mission and geographical distribution, and the age of the person infected.

#### *T. pertenue* (*T. p. subsp. pertenue*)

Yaws, which is also called pian, framboesia, and buba, occurs mainly in hot humid tropical regions in sub-Saharan Africa, particularly West and Central Africa, parts of South America, the Caribbean, Indonesia, and the Pacific Islands. Infections increase during the rainy season.

*T. pertenue* is transmitted mainly among children by direct skin contact with exudate from an infectious lesion infecting broken skin, often on the legs. Transmission is facilitated by poverty, overcrowding, inadequate water for bathing and washing clothes, and infected communities not being treated.

The treponemes multiply at the site of infection, forming a papilloma which heals in 3–6 months. Following the spread of organisms in the body, secondary exudative papillomas form. They become covered with a yellow crust. When the yellow surface is removed, lesions have a raspberry-like appearance (framboesides). The parts of the body most affected are the face, hands, legs, feet, and moist skin folds. Bone and cartilage may also become infected. In those co-infected with HIV, lesions may be severe. The secondary lesions heal and the disease becomes latent. In untreated patients, infectious lesions may reappear for up to 5 years after infection. Nocturnal bone pain is common. Marked thickening of infected areas can lead to disfigurement and destructive ulceration of the nasopharynx can occur in advanced untreated yaws.

Yaws is usually diagnosed clinically. Treponemes can often be found in exudative skin lesion (wear protective gloves and handle specimens with care because the treponemes are highly infectious). If required, the non-specific and specific treponemal antibody tests as used in the diagnosis of syphilis, can also be used to assist in the diagnosis of yaws.

#### *T. endemicum* (*T. p. subsp. endemicum*)

Endemic syphilis, also known as non-venereal syphilis, bejel, njovera, firzol, siti and dichuchwa, is found in hot, dry and arid regions in the Arabian peninsula, along the southern border of the Sahara desert (the Sahel), and in some areas in central Asia. Children (2–15 y) are mainly infected. Transmission is by direct contact with an infected lesion via contaminated drinking vessels. Flies may also be vectors.

A primary lesion is not often seen in endemic syphilis. Infection usually takes the form of mouth and lip lesions, sometimes accompanied by hoarseness. Following spread of the organisms, other non-itchy lesions form mainly on the moist surfaces of the body (axilla, genital areas). In endemic syphilis (like in yaws), the long bones of the legs and cartilage may become infected causing nocturnal leg pain. Some untreated patients become deformed and disabled. As with yaws, endemic syphilis is usually diagnosed clinically. Treponemes may be found in lesions and if required cardiolipin and specific treponemal antibody tests can be used to assist in diagnosis.

#### *T. carateum*

Pinta occurs only in remote rural communities in parts of Mexico and northern South America. The disease is also known as carate, mal del pinto, and azul. It differs from yaws and endemic syphilis by affecting both children and adults of all ages. Only the skin is infected and there is no latent non-infectious stage (skin lesions can remain infectious for many years).



Pinta is transmitted by direct lesion to skin contact. The primary lesion is usually on a leg, foot, forearm, or back of a hand. Secondary red itchy skin lesions form 3–9 months after infection. With age, the lesions become pigmented. Infected lesions when healed, leave areas with loss of normal skin pigment. Most infections can be diagnosed clinically. Many treponemes can be found in skin lesions. Serological tests can assist in diagnosis.

*Further reading:* Additional information on infections caused by *T. pertenue*, *T. endemicum* and *T. carateum* and their differentiation from other skin diseases can be found in the colour illustrated WHO *Handbook of endemic treponematoses*, WHO, 1984, obtainable from WHO Publications, WHO, 1211 Geneva, 27-Switzerland. Clinical information and current treatment of endemic treponematoses can be found in 21st edition (2003) *Mansons Tropical Diseases*, Saunders, Elsevier.

### 7.18.33 *Leptospira interrogans*

#### Pathogenicity

*L. interrogans* causes leptospirosis, a zoonotic disease with humans becoming infected following direct or indirect contact with urine from infected animals. Most infections are associated with rats and other rodents, cattle, pigs, or dogs. Epidemics can occur following flooding or other disasters which bring humans into close contact with infected animals or contaminated water. Person to person transmission is rare.

#### Serovars of *L. interrogans*

Over 200 serovars of *L. interrogans* are known to infect domestic and wild animals and are capable of infecting humans. *L. interrogans* serovar *Icterohaemorrhagiae* commonly infects rats. Cattle are often infected with serovars *Pomona* and *Hardjo*, pigs with *Pomona* and *Tarassovi*, and dogs with *Icterohaemorrhagiae* and *Canicola*. Most animal hosts do not develop symptomatic disease. Leptospire are excreted in the animal's urine. The organisms can survive for many weeks in soil and water, especially when conditions are slightly alkaline and the temperature is 28–32°C.

Persons most at risk are those whose lifestyle or work involves the risk of skin or mucous membrane contact with mud contaminated with infected animal urine, e.g. those who work in rice fields and sugarcane fields, livestock farmers, irrigation canal workers, meat and animal handlers, fresh-water fish pond workers, veterinarians, sanitation and pest control workers. Leptospire generally gain entry through small cuts or abrasions on the skin.

Any serovar of *L. interrogans* can cause clinical disease ranging from a mild flu-like illness to severe

life-threatening hepatorenal failure. There are no serovar specific presentations. Patients with suspected leptospirosis require treatment as soon as possible.

#### Leptospirosis and Weil's syndrome

The mild form of leptospirosis is often misdiagnosed as a viral illness or influenza. The more serious form of the disease is characterized by high fever, headache, hypotension, pains in the muscles and legs, abdominal pain, weakness, and often redness of the eyes and a rash. Some patients develop meningitis (lymphocytic), jaundice following liver cell damage, thrombocytopenia with haemorrhagic symptoms, and renal failure.

*Weil's disease, or syndrome:* This term is occasionally used to describe the severe form of leptospirosis in which there is liver damage with jaundice and renal failure. Hepatorenal failure may be accompanied by bleeding from the gastrointestinal tract and elsewhere. Death can occur from renal failure or severe haemorrhage.

#### LABORATORY FEATURES

The role of the laboratory is to support a clinical diagnosis of leptospirosis, prevent misdiagnosis and to investigate epidemics of the disease.

*Specimens:* Mainly blood for serological tests.

**Urine:** Although leptospire may be present in the urine by about the 10th day of infection and for up to 1 month or longer, urine is not the specimen of choice for diagnosing leptospirosis. By the time leptospire may be present in urine, antibodies are detectable in serum. Serological tests offer a more rapid and reliable confirmation of infection.

#### Morphology

*L. interrogans* is a thin tightly coiled spirochaete, measuring 6–20 × 0.1 µm. One or both ends of the spirochaete are hooked as shown in colour Plate 61.

Morphologically, *L. interrogans* is indistinguishable from other leptospire of the genus *Leptospira* including the free-living saprophytic species *L. biflexa*.

Leptospire like treponemes are not easily stained. They may be seen (but not often) in wet preparations by dark-field microscopy using a 40× objective with 10× eyepiece and bright illumination (see pp. 122–123 in Part 1 of the book). The organisms show a rapid bending and rotating motility. Considerable experience is necessary to distinguish leptospire from artefacts.

#### Culture

In Reference Laboratories, specimens can be cultured for *L. interrogans*. The organism can be grown aerobically at 28–30°C in a semi-solid serum culture medium or a Tween-albumin (TA) medium. Cultures are examined weekly for leptospire by

dark-field microscopy. Because it takes several weeks for *L. interrogans* to multiply in cultures, isolation techniques are of limited value in the diagnosis of acute leptospirosis.

### Serology

This is the usual method of confirming leptospirosis. Leptospiral antibodies begin to appear in the blood towards the end of the first week of infection, reach a peak in the third or fourth week, and then begin to decline as the patient recovers. The antibodies which appear first are of the IgM type. These may be followed by IgG antibodies. IgM class antibodies may persist for several months. Whenever possible, paired sera (acute and convalescent samples) should be tested to demonstrate a four-fold rise in antibody titre.

Serological tests used to investigate leptospirosis can be divided into:

- Tests which detect *Leptospira* specific antibodies i.e. genus specific, such as *LeptoTek Dri-Dot* and *LeptoTek Lateral Flow*.
- Microscopical agglutination test (MAT) which is used to identify the infecting serovar.

Knowing the serovar is not required for clinical diagnosis and treatment but is important in identifying the source of infection and implementing control measures. Whenever possible, serum which gives a positive *Leptospira* antibody screening test should be sent to a reference laboratory for confirmatory testing and identification of the infecting serovar.

### **LeptoTek Dri-Dot to detect specific *Leptospira* antibodies**

Developed by the Royal Tropical Institute (KIT) in Amsterdam, *LeptoTek Dri-Dot* is a rapid (30 second), easy to perform test to detect *Leptospira* antibodies in serum. It consists of coloured latex particles activated with *Leptospira* antigen and dried on an agglutination card. A drop of serum is mixed with the antigen to form a homogeneous suspension and rotated for 30 seconds.

Agglutination of the blue latex particles indicates the presence of *Leptospira* antibodies in the sample (see colour Plate 63). Strong agglutination visible *within 30 seconds* (not longer) is highly consistent with current or recent leptospiral infections. Specificity of the test is 91%. Sensitivity of the assay is highest (91.2%) for serum samples collected 10–30 days after the onset of disease. *LeptoTek Dri-Dot* agglutination cards can be stored at room temperature (up to 45 °C). They need to be kept in a dry place and protected from direct sunlight.

**Availability:** *LeptoTek Dri-Dot* is available from bioMérieux. See Appendix 11 for contact details.

### **LeptoTek Lateral Flow test**

This is an immunochromatographic test in cassette form (lateral flow), also developed by the Royal Tropical Institute (KIT) in Amsterdam, which detects anti-*Leptospira* IgM antibodies. The test is easy to perform and takes 10 minutes. It has a sensitivity of 81% and specificity of 90% for samples collected after 10 days and a sensitivity of 66% and specificity of 90% for samples collecting during the first 10 days of illness (figures similar to IgM ELISA). The *LeptoTek Dri-Dot* test has a higher sensitivity (72%) for samples collected during the first 10 days. *LeptoTek Lateral Flow* test can be stored at ambient temperature (up to 45 °C).

**Availability:** *LeptoTek Lateral Flow* test is available from bioMérieux (see Appendix 11).

### **Confirmatory and serovar specific tests**

The microscopical agglutination test (MAT) is considered the reference test for leptospirosis diagnosis, and is used to identify the infecting serovar. It is however a complex technique requiring specialist trained staff and the facilities of a reference laboratory. Details of the test can be found in the WHO and International Leptospirosis Society publication: *Human Leptospirosis – Guidance for diagnosis, surveillance and control* (see Further information).

### **Haematological and biochemical tests**

- *Measurement of haemoglobin, total and differential white cell count, platelet count:* A slight to moderate leucocytosis with neutrophilia occurs with leptospirosis. This helps to differentiate the disease from viral hepatitis, dengue and other viral infections in which the white count is normal or low with neutropenia. The platelet count is frequently low in leptospirosis.
- *Renal function tests:* The blood urea and serum creatinine are often slightly raised. Both are markedly raised when there is renal failure.
- *Serum bilirubin and serum aminotransferases:* In jaundiced patients the serum bilirubin (direct) is raised. Serum aminotransferases (ALT and AST), however, are normal or only up to three times the normal limit. This finding helps to differentiate leptospirosis from viral hepatitis in which the enzymes are raised. Acute icteric leptospirosis is often misdiagnosed as viral hepatitis.
- Serum amylase is raised.

## FURTHER INFORMATION

World Health Organization, International Leptospirosis Society (ILS). *Human Leptospirosis: Guidance for diagnosis, surveillance and control*, WHO/ILS, 2003.

## WEBSITES

- International Leptospirosis Society website [www.med.monash.edu.au/microbiology/staff/adler/ilspage.htm](http://www.med.monash.edu.au/microbiology/staff/adler/ilspage.htm)
- Leptospirosis epidemiological website [www.leptonet.net](http://www.leptonet.net)
- WHO website [www.who.int](http://www.who.int) (use Search facility to locate leptospirosis).

### 7.18.34 *Borrelia* that cause relapsing fever and other pathogenic borreliae

#### Pathogenicity

There are two forms of relapsing fever:

- Louse-borne relapsing fever
- Tick-borne relapsing fever

#### Louse-borne relapsing fever

This is caused by *Borrelia recurrentis*, a human pathogen which is transmitted from person to person by the body and head louse, *Pediculus humanus*. Human infection occurs when the borreliae enter damaged skin following the crushing of an infected louse. The louse becomes infected when sucking blood from a person whose blood contains *B. recurrentis* (louse remains infected for life). Louse-borne relapsing fever can occur as an epidemic especially in conditions which favour the transfer of lice from one host to another, e.g. overcrowding, poverty, famine, war. The disease is particularly common in the highlands of Ethiopia and Burundi. Lower prevalences are found in north-west and East Africa, Peru, Bolivia and parts of India, Asia and China.

#### Clinical features of louse-borne relapsing fever

Relapsing fever is characterized by recurring periods of high fever with severe headache, body pains, vomiting and often a cough and dyspnoea. There may be up to four relapses of decreasing severity at 5–9 day intervals. The borreliae concentrate in the liver and spleen where they multiply causing damage to the liver and spleen which become enlarged. Jaundice and haemorrhagic symptoms develop. Bleeding often occurs in the skin causing a petechial rash and nosebleeds are common.

The patient becomes anaemic and thrombocytopenic and the total white cell count may be raised with neutrophilia. A Jarische-Herxheimer reaction may occur during the illness or

following treatment. In severe heavy infections, death may occur from hepatic or cardiac failure.

Borreliae may also infect the central nervous system causing meningitis (lymphocytic) and occasionally the organisms can be seen in cerebrospinal fluid.

#### Tick-borne relapsing fever

This is caused by *Borrelia duttoni* in East, Central, and South Africa and other species of *Borrelia* in other parts of the world.

Six other *Borrelia* species cause tick-borne relapsing fever in North and West Africa, South America, Central America, USA, Mediterranean region and Western China.

Tick-borne relapsing fever is transmitted by soft ticks of the genus *Ornithodoros*. The ticks live in the cracks of walls and floors and in animal burrows. Both nymphs and adult ticks can transmit borreliae (ticks can also transmit borreliae to new generations of ticks). Humans are the main reservoir of *B. duttoni* but in some areas of the world, rodents are also important reservoirs of *Borrelia* species. Infection occurs through the bite of an infected tick or when borreliae (present in coxal fluid secreted by the tick when it feeds) enter the skin or mucous membranes. The borreliae can also be transmitted by blood transfusion. Tick-borne relapsing fever is an endemic disease, it rarely causes epidemics.

#### Clinical features of tick-borne relapsing fever

These are similar to those described for louse-borne relapsing fever except tick-borne relapsing fever is usually a less severe illness. Anaemia and jaundice are usually less common. Meningitis, however, is more common. Young children, young adults, and pregnant women are more commonly infected in endemic areas (reduced immunity).

#### LABORATORY FEATURES

*Specimens:* To detect borreliae, anticoagulated blood or blood smears, should be collected *during times of fever* because this is when the organisms will be present in their highest concentration. When indicated, cerebrospinal fluid may be required to investigate meningitis.

#### Morphology

*Borrelia* organisms are large spirochaetes, measuring 10–20 × 0.5 μm with uneven size coils. They can be seen in thick (and occasionally thin) blood smears stained with Giemsa or Field's stain (see colour Plate 64). Often they are detected when examining smears for malaria parasites (sometimes both malaria parasites and borreliae are seen). In louse-borne relapsing fever, large numbers of borreliae can often be seen massed together between

blood cells. Occasionally they can be seen in white cells.

Microscopically it is not possible to differentiate the different species of *Borrelia*.

#### *Concentrating borreliae*

If borreliae are not seen in a thick film, it is often possible to concentrate them by centrifuging EDTA or heparin anticoagulated blood in a capillary tube for 3–5 minutes. The motile borreliae will be found in the plasma immediately above the buffer coat layer (white cells and platelets). The part of the capillary viewed must be free from finger marks and the condenser iris must be closed sufficiently to give good contrast. When motile organisms are seen, examine a stained preparation to confirm that the organisms are borreliae.

#### **Culture**

Although *Borrelia* species have been cultured in Kelly's medium, growth of the organisms is not easily achieved. Culture is not used routinely as a method of diagnosing relapsing fever.

#### **Serology**

Several serological tests have been developed for diagnosing relapsing fever, but antigens for the tests are not generally available and many show cross-reactions with *Treponema*.

### ***Borrelia vincenti***

*B. vincenti* in association with *Fusobacterium* species and other Gram negative anaerobes causes:

- acute ulcerative gingivitis (Vincent's angina)
- tropical ulcer

#### **Acute ulcerative gingivitis**

This is an inflammatory condition often seen in children with malnutrition or others in poor health. *B. vincenti* with fusobacteria and other Gram negative organisms can be found with pus cells in exudate from infected tissue. Dilute carbol fuchsin (1 in 10 dilution) should be used as a counterstain in the Gram technique because this stains Gram negative borreliae more intensely, making it easier to detect them (see colour Plate 65).

#### **Tropical ulcer**

The ulcer is commonly found on the ankle or lower part of the leg, often of malnourished persons. It may form following minor injury or an insect bite. Often there is considerable tissue damage and the

ulcer is painful in the first few weeks. Some ulcers heal spontaneously. *B. vincenti* with fusobacteria and other Gram negative anaerobic rods can be found in exudate from the ulcer. Staphylococci and *beta*-haemolytic streptococci are often secondary invaders. Smears should be Gram stained in the same way as previously described, i.e. using dilute carbol fuchsin as the counterstain.

### ***Borrelia burgdorferi***

*B. burgdorferi* and other *Borrelia* species cause Lyme disease which is transmitted by hard ticks of the genus *Ixodes*. Field mice, voles, sheep, horses, and other mammals are among the reservoir hosts. Humans become infected by the bite of an infected hard tick. The disease is characterized by a rash (erythema chronicum migrans) which spreads from the site of the tick bite, forming a circular erythema with central clearing. This is usually accompanied by fever, malaise, and often lymphadenopathy. Several weeks or months later, some patients develop arthritis, peripheral neuritis, chronic meningoencephalitis, and cardiac complications including myocarditis and pericarditis.

Lyme disease was first recognized in the USA in 1977. Since then epidemics have also been reported from Europe, Australia, and other parts of the world. There is however, very little information from developing countries.

Lyme disease is usually diagnosed serologically using haemagglutination, ELISA, and immunofluorescence techniques. When used in several African countries, most of the commercially available tests gave cross-reactions with other spirochaetes (*Borrelia* and *Treponema* species). A full clinical history is required and serological tests need to be interpreted with care.

## **7.18.35 *Rickettsia* species and related organisms**

*Note:* The basic features of rickettsial organisms are summarized in subunit 7.2.

#### **Pathogenicity**

*Rickettsia* species are divided into three main groups:

- **Typhus group:** Includes *R. prowazekii* which causes epidemic typhus (louse-borne typhus) and *R. typhi* which causes endemic typhus (murine, or flea-borne typhus).
- **Scrub typhus group:** Contains *O. tsutsugamushi* which causes mite-borne scrub typhus, also known as Japanese river fever and Kedani mite disease.
- **Spotted fever group:** Includes those rickettsiae

that cause Rocky Mountain spotted fever, African and Indian tick typhus, Fièvre boutonneuse, rickettsialpox, and other spotted fevers. The group includes *R. rickettsii*, *R. conorii*, *R. akari* and *R. africae*.

*Rickettsia* species of importance in tropical countries, their arthropod vectors, (lice, ticks, fleas, mites), main reservoir hosts, and the diseases they cause are summarized in Chart 7.14. A person becomes infected either by being bitten by an infected vector or by scratching vector faeces containing rickettsiae into the skin.

#### Rickettsial infections

The symptoms of rickettsial infections are due to the invasion and multiplication of rickettsiae in the endothelial cells of small blood vessels, smooth muscle cells, and histiocytes. The tissues most affected are those of the skin, heart, brain and lungs.

There is a local cellular response with the infected cells becoming inflamed and severely damaged. Capillaries become blocked and bleeding may occur in severe infections.

Most infections are characterized by high continuous fever, severe headache and body pains, marked weakness, and an enlarged spleen and liver. A macula or maculopapular rash, which usually appears towards the end of the first week,

**Chart 7.14 Medically important *Rickettsia* species in tropical countries**

Organism Distribution	Disease	Vector	Reservoir Host(s)
<i>R. prowazekii</i> Africa, Asia, South America	Epidemic typhus Brill-Zinsser	Body louse	Humans Flying squirrels
<i>R. typhi</i> Worldwide	Endemic typhus	Fleas	Rats Mice
<i>O. tsutsugamushi</i> India, SE Asia, South Pacific	Scrub typhus	Trombiculid mite (chigger)	Mites, rodents
<i>R. rickettsii</i> USA, South America	Rocky Mt spotted fever	Ixodid tick	Rodents, dogs
<i>R. conorii</i> Africa, India, Mediterranean	Tick typhus Fièvre boutonneuse	Ixodid tick	Wild mammals, dogs
<i>R. akari</i> Asia, S. Africa USA, Russia	Rickettsial pox	Mites	Rodents

#### Notes:

In recent years a new *Rickettsia* species called *R. africae* has been recognized also as causing African tick bite fever. Reservoir hosts are rodents.

R = *Rickettsia*, O = *Orientia*

may become haemorrhagic especially in Rocky Mountain spotted fever, louse-borne typhus, and occasionally in tick typhus. There may also be oedema.

The eyes are frequently affected, the face flushed, and nosebleeds may occur. There is often severe vomiting. In about the second week of infection, the patient may become very ill with signs of brain damage including mental dullness and confusion which may lead to delirium and coma.

In severe infections, death can occur from general toxæmia, encephalitis, myocarditis, or pneumonia. The most severe symptoms are found in louse-borne typhus, scrub typhus, and Rocky Mountain spotted fever.

With scrub typhus, tick typhus and rickettsialpox, a black scab (eschar) may form at the site of infection and the surrounding lymph glands become inflamed. These features, however, are not always seen in those living in endemic areas.

Brill-Zinsser disease is a relapsing form of typhus caused by *R. prowazekii*. It is milder than primary epidemic typhus and the early antibody response is IgG rather than IgM.

#### LABORATORY FEATURES

Most rickettsial diseases are diagnosed serologically by testing paired sera (acute and convalescent samples).

*Note:* Because rickettsiae are obligate intracellular organisms, the techniques used for culturing viruses can also be used for isolating rickettsiae. Such techniques, however, can only be performed in Reference Laboratories.

#### Morphology

Rickettsiae are pleomorphic organisms, forming coccal or rod-like forms. They are very small, measuring less than 0.5 µm in diameter. In smears of infected tissue stained with Giemsa, Castaneda, or Macchiavello stains, rickettsiae can sometimes be detected in groups within the nuclei of infected cells or close to cells.

#### Serology

In most rickettsial infections, antibodies can usually be detected only in the later stages of illness. IgM antibodies are produced first followed by IgG antibodies which persist in the serum for several years. Immunity against louse-borne typhus and the spotted fever group of rickettsiae lasts for about 1 year after infection. Reinfection with scrub typhus is rare.

#### Antibody tests

Paired sera should be tested to demonstrate a rise in titre during illness. A range of antibody tests to investigate rickettsial infections is available from PanBio Ltd. They include indirect fluorescence antibody tests (IFAT) and enzyme linked

immunosorbent assays (ELISA). Details of these can be obtained from PanBio (see Appendix 11).

### Weil-Felix reaction

This non-specific test is based on cross-reactions which occur between antibodies produced in acute rickettsial infections and the OX 19, OX 2, and OXK strains of *Proteus* species. Dilutions of patient's serum are tested against suspensions of the different *Proteus* strains.

*Proteus* OXK strain agglutinins are produced in scrub typhus and OX 2 and OX 19 agglutinins in other rickettsial diseases (see following Chart). The Weil-Felix reactions give a high percentage of false negative results. These are particularly common in scrub typhus. False positive results are obtained in other diseases such as leptospirosis and relapsing fever (diseases which require differentiating from rickettsial infections), *Proteus* infections, brucellosis and acute febrile illnesses. The predictive value of the Weil-Felix test increases when both acute and convalescent samples can be tested to look for a rise in antibody titre. Whenever possible an IFAT, ELISA, or immunochromatographic assay should be used instead of the Weil-Felix test.

Organism	Weil-Felix Reactions		
	OX 19	OX 2	OXK
<b>Typhus Group:</b> <i>R. prowazekii</i> *	+++	+/-	-
<i>R. typhi</i>	+++	+/-	-
<b>Scrub Typhus Group:</b> <i>O. tsutsugamushi</i>	-	-	+++/-
<b>Spotted Fever Group:</b> <i>R. conorii</i>	+/++	+/++	-
<i>R. rickettsii</i>	+/++	+/++	-

\*In louse-borne typhus, the antibody titre against OX 19 may rise to 1 in 500 or more in the third or fourth week of infection, but rarely in Brill-Zinsser disease.

**Important:** In endemic areas, district laboratories wishing to test for rickettsial infections should consult their Regional or Central Public Health Laboratory regarding the most appropriate test to use and how to interpret test results.

### Other laboratory findings in rickettsial infections

**White blood cell count:** In scrub typhus this is usually low with an absolute lymphocytosis. In louse-borne

typhus and murine typhus, there is usually a slight leucocytosis in the later stages of infection with an increase in mononuclear cells. A leucocytosis with neutrophilia may occur in severe tick-bite fever and other rickettsial diseases with serious complications.

**Platelets:** Thrombocytopenia is usually found in severe infections.

**Coagulation tests:** These may be abnormal, especially in severe infections. Serum fibrin degradation products (FDP's) are raised when there is disseminated intravascular coagulation (DIC).

**Cerebrospinal fluid:** With encephalitis, the fluid contains cells (mainly lymphocytes) and an increase in total protein.

**Blood urea and serum creatinine:** These may be raised, especially when there is abnormal renal function.

**Urine:** This contains protein and in severe infections, red cells and casts may also be found.

### FURTHER INFORMATION

Readers are referred to Chapter 50 Rickettsial infections in 21st edition *Mansons Tropical Diseases*, 2003, Saunders, Elsevier.

### *Coxiella burnetii*

*C. burnetii* causes Q ('query') fever which has a worldwide distribution. In Zaire it is known as Red River Fever. Natural reservoir hosts include cows, sheep, goats, rodents, wild mammals and several species of bird. *C. burnetii* is transmitted by ticks but unlike rickettsiae, it can also be transmitted without a vector via placental tissue, dust particles, faeces and infected milk. Human infection is commonly by inhaling contaminated aerosols and dust and occasionally by drinking untreated milk or by handling infected animals or their tissues.

*C. burnetii* infects the cells of the spleen and liver causing enlargement of these organs. Q fever resembles influenza with high fever, severe headache, fatigue, and body pains. Usually there is no rash or only a slight one. Serious complications of Q fever include pneumonitis, chronic infective endocarditis, and liver disease.

Serological tests used to assist in the diagnosis of Q fever (usually performed in a Reference Laboratory) include complement fixation test (CFT) and indirect microimmunofluorescence test (IFAT). Microimmunofluorescence is more sensitive than CFT in the early stages of infection.

During infection, *C. burnetii* undergoes antigenic variation. In the early stages of infection the organisms exist in phase 2 and the antibody body response is to phase 2. In serological tests, phase 2 antigen is therefore used to diagnose acute Q fever. In chronic infections, antibodies to phase I are present and can be tested using phase I antigen.

Agglutinins to *Proteus* strains are not produced in Q fever and therefore the Weil-Felix reaction (as used to investigate rickettsial infections) is negative.

### *Bartonella quintana* and *Bartonella henselae*

***B. quintana*** (formerly *Rochalimaea quintana*): Causes trench fever, a louse-borne infection (originally associated with epidemics among troops in the First World War) which can be found in Mexico, some parts of Africa and the Far East. Most infections are mild with fever, headache, muscle pain, macular rash, nausea and vomiting. The fever may be recurring (e.g. quintan fever, occurring every 5 days). More serious infections have been reported in those infected with HIV. Most infections are diagnosed clinically. Laboratory investigations include blood culture and testing serum for antibody (in Reference Laboratory).

***B. henselae*** (previously *Rochalimaea henselae*): Causes opportunistic infections in those with immunosuppression, e.g. HIV disease. It is associated with fever, bacteraemia and a condition called cutaneous bacillary angiomatosis, (vascular lesions resembling Kaposi's sarcoma in the skin and visceral organs). Infections can be diagnosed by blood culture (in Reference Laboratories). *B. henselae* also causes cat-scratch disease, a mild self-limiting lymphadenopathy, usually found in children following contact with cats.

## 7.18.36 *Bartonella bacilliformis*

### Pathogenicity

*B. bacilliformis* causes bartonellosis, also called Carrion's disease. It is found in South America, particularly in the valleys of the foothills of the Western Andes (Peru, Columbia, Bolivia, Ecuador). The organism is transmitted by *Lutzomyia* sandflies. Transmission is increased during the rainy season. Humans, particularly healthy carriers, are the main reservoirs of *B. bacilliformis*. Infections resembling bartonellosis (possibly caused by other *Bartonella* species) have been reported from other countries.

### Bartonellosis

The disease is characterized by acute haemolytic anaemia (infected and non-infected cells are haemolyzed) with high fever (Oroya fever), severe headache, and pains in the joints and bones. The organism invades and destroys red blood cells and also infects the cells of the reticuloendothelial system. There is enlargement of the spleen, liver, and lymph nodes. A serious complication is meningoencephalitis. The fatality rate in acute bartonellosis is reported as 10–40% with death usually being caused by intravascular haemolysis or *Salmonella* septicaemia.

About 30–40 days after infection, flat lesions or nodules resembling warts appear on the skin. This stage of the illness

is called verruga peruana. The high fever, haemolysis and joint pains gradually subside.

### LABORATORY FEATURES

**Specimens:** Blood collected during the fever stage of the illness is required to demonstrate the organisms in red cells (and to measure haemoglobin). In the verruga peruana stage, the organisms may be detected in smears from skin lesions. When there is meningoencephalitis, many organisms can be found in the c.s.f. which will also contain cells and a raised protein.

### Morphology

*B. bacilliformis* can be found often in large numbers in red cells. The organism is pleomorphic, occurring as small rods measuring  $2 \times 0.5 \mu\text{m}$  or as very small oval or coccid forms about  $1 \mu\text{m}$  in diameter (see colour Plate 66). X and Y forms may also be seen.

When stained with Giemsa or other Romanowsky stain, *B. bacilliformis* stains red-purple. The organism is Gram negative.

### Culture

*B. bacilliformis* is a strict aerobe and can be grown on blood agar. Colonies usually appear after 5 or 6 days incubation at 25–28 °C. They show slight haemolysis.

### Haematological findings in bartonellosis

Haemolytic anaemia develops soon after infection and can be severe with an increase in serum bilirubin. A reticulocytosis develops and nucleated red cells can be seen in blood films. There is usually a leucocytosis with neutrophilia. Platelet numbers are either normal or reduced.

## 7.18.37 *Chlamydiae*

**Note:** The general features of chlamydiae are summarized in subunit 7.2.

### Pathogenicity

Human infections are caused by:

*Chlamydia trachomatis*

*Chlamydia pneumoniae*\*

\*Formerly *Chlamydia pneumoniae*

*Chlamydia psittaci* is mainly a pathogen of birds. Occasionally it causes disease in humans.

**C. trachomatis** causes:

- Eye disease:
  - Trachoma (serovars A, B, Ba, C)
  - Inclusion conjunctivitis (serovars D to K)
  - Neonatal ophthalmia (serovars D to K)

**Trachoma**

Trachoma is a serious eye disease in which acute inflammatory changes in the conjunctiva and cornea lead to scarring and eventual blindness. Other bacterial pathogens may also infect the eye in association with *C. trachomatis*, causing further inflammation and eye damage. High infection rates are found in developing countries in poor and arid rural areas, particularly among women and children. It is the second cause of blindness in the world after cataract. WHO estimates that there are over 140 million people infected, about 6 million already blind or severely visually impaired and 84 million cases of active disease in need of treatment.

Trachoma is spread by the transfer of infected discharge from the eye of one person to another by flies (important carriers) or contaminated hands, clothing, or towels. Poverty, overcrowding, poor hygiene and inadequate water supplies help to spread trachoma in endemic areas. In 1997, a *WHO Alliance for the global elimination of trachoma* was established to intensify action against the disease and implement new methods of rapid assessment and more effective treatment with a view to eliminating blinding trachoma by 2020.

*Further information:* This can be found on the WHO website [www.who.int](http://www.who.int). Key in trachoma using the Search Facility.

**Inclusion conjunctivitis**

This causes inflammation of the conjunctiva (follicular conjunctivitis) with a mucopurulent discharge and occasionally keratitis. It mainly affects children and occasionally adults following contaminated hand to eye contact.

**Neonatal ophthalmia**

Also known as inclusion blennorrhoea, neonatal ophthalmia occurs in newborn infants (about 7–12 days after delivery) following infection from cervical secretions during birth. It is thought up to 50% of infants born of mothers with *Chlamydia* cervicitis, develop mucopurulent conjunctivitis. Some infants also develop pneumonia.

- Genital tract infections (serovars D-K)
 

In men, *C. trachomatis* causes urethritis (non-specific urethritis), which can lead to epididymitis and occasionally prostatitis. A rare complication of non-gonococcal urethritis is Reiter's syndrome, an auto-immune disease causing arthritis, urethritis and uveitis.

In women, *C. trachomatis* causes mainly cervicitis and endometritis which can lead to salpingitis, pelvic inflammatory disease (PID), and infertility. For pregnant women, there is an increased risk of ectopic pregnancy. Infants born of women

with cervicitis can become infected during birth and subsequently develop inclusion conjunctivitis and occasionally pneumonia.

**Non-gonococcal urethritis**

*Chlamydia* urethritis in men is accompanied by urethral discharge, frequency, and dysuria.

**Chlamydia genital infections in women**

In women, primary infections are often without symptoms (60% or more). Some patients have vaginal discharge, dysuria and frequency. *Chlamydia* infection is often accompanied by other sexually transmitted infections, particularly candidiasis, trichomoniasis and gonorrhoea.

- Lymphogranuloma venereum, or LGV, (serovars L1–L3). LGV is a sexually transmitted disease. It is also known as tropical, or climatic bubo, because it is found mainly in tropical countries (India, Southeast Asia, tropical Africa, South Africa and the West Indies), particularly in urban areas.

**LGV**

The organism infects anogenital lymphoid tissue. At the site of infection a genital papule forms which usually heals within a few days. The infection spreads via the lymphatics, causing acute lymphadenitis with inguinal and femoral lymph nodes becoming enlarged. Painful buboes form which discharge pus. Some patients develop genital ulcers, fistulas and rectal strictures. Men are more commonly infected than women. In women, the vagina and cervix become infected and infection often spreads to the rectum.

- Pneumonia and pneumonitis (serovars D–K)
 

Most infections occur in newborn infants 2–12 weeks after birth (particularly in those with neonatal ophthalmia), or as opportunistic infections in immunocompromised persons and those already in poor health.

**Chlamydia pneumoniae** causes:

- Atypical pneumonia, usually a mild respiratory infection with sore throat, cough, fever, and symptoms associated with asthma. It is transmitted by inhaling infected aerosols.

**LABORATORY FEATURES**

Outside of specialist laboratories, most ocular and genital *Chlamydia* infections are diagnosed clinically or immunologically by detecting specific chlamydial antigen in preparations from infected sites (see following text). Nucleic acid tests and tissue cultural techniques are used in reference laboratories.

Occasionally in neonatal conjunctivitis and trachoma it may be possible to detect *Chlamydia*



inclusion bodies (when present in large numbers) in epithelial cells in Giemsa or iodine stained smears. *C. trachomatis* is rarely detected in genital specimens by direct microscopy.

A presumptive diagnosis of acute chlamydial infection in male patients is often made when a Gram stained urethral smear contains more than 5 pus cells/high power field (100 × objective) and no intracellular Gram negative diplococci (or more than 20 pus cells in a first voided urine specimen).

#### **Collection of conjunctival scrapings (by a medical officer)**

After anaesthetizing the conjunctiva with anaesthetic eye drops, blot away any discharge and using a spatula with a thin blunt end, scrape the whole of the conjunctiva. Spread the specimen evenly on a slide. As soon as the preparation is air-dry (protect it from flies and dust), fix it with methanol for 2–3 minutes if the preparation is to be Giemsa stained. If the preparation is for fluorochrome staining, fix it with acetone or other fixative as recommended in the fluorescence test technique.

#### **Collection of genital specimens to detect chlamydial antigen**

An endocervical specimen is required from women and a urethral or urine specimen (depending on antigen test) from men. Specimens must be collected correctly.

##### *Endocervical specimen*

Using a swab moistened with sterile saline, cleanse the endocervix, removing any excess mucus or inflammatory exudate (use a sterile speculum to visualize the area). Use a fresh sterile swab (cotton wool-tipped on a plastic stick) to collect the specimen, inserting it about 20 mm into the endocervical canal and gently rotating it against the wall of the endocervix. Carefully withdraw the swab, *avoiding contact with vaginal secretions*. Place the swab in a dry sterile tube and deliver it to the laboratory.

##### *Urethral specimen*

Insert a sterile swab (cotton wool-tipped on a plastic stick) about 30 mm into the urethral canal and gently rotate it against the wall of the urethra. Place the swab in a dry tube and deliver it to the laboratory.

##### *Urine*

Several immunological test kits for detecting *C. trachomatis* antigen in genital specimens can also be

used to test male urine specimens. Instruct the patient to collect 20–50 ml of a first voided morning urine specimen into a sterile container (provided by the laboratory).

**Note:** When a delay in a urogenital specimen reaching the laboratory is unavoidable, keep the swab or urine refrigerated at 2–8°C. When transporting the specimen to a distant laboratory, send it in a cool box.

#### **Detection of *C. trachomatis* in Giemsa and iodine stained conjunctival smears**

Examine the smear microscopically using the 40× and 100× objectives. Look for epithelial cells that contain inclusion bodies. *C. trachomatis* inclusion bodies vary in size and shape and lie in the cytoplasm of the host cell often touching and forming a mantle around the cell's nucleus (chlamydia means mantle).

*Giemsa preparation:* When stained with Giemsa stain at pH 7.2 (see subunit 7.3.10), a *C. trachomatis* inclusion body may appear as a blue-mauve stained mass consisting of closely packed reticulate (initial) bodies, or as a less dense mass consisting of mauve-red staining elementary particles (bodies). Both types of inclusion body are shown in colour Plate 67. The nucleus of the host cell stains pink-mauve.

A host cell may contain only a single inclusion body containing reticulate bodies and, or, elementary particles, or several inclusion bodies at various stages of development.

##### *Differentiation of *C. trachomatis* from bacteria*

When examining Giemsa stained conjunctival smears, care must be taken not to confuse *C. trachomatis* reticulate bodies with bacteria such as *Neisseria*, *Haemophilus* and *Moraxella* species, all of which stain blue and can be found in the cytoplasm of cells. To avoid this, always examine a Gram stained smear as well as a Giemsa stained preparation.

Report the smear as 'Chlamydial inclusion bodies present' or 'No chlamydial inclusion bodies seen'.

*Iodine preparation:* *C. trachomatis* inclusion bodies contain glycogen which stains brown with iodine. It is therefore possible to screen for *C. trachomatis* inclusion bodies in a wet iodine preparation (Reagent No. 44) using a 40× objective (see colour Plate 67).

Examination of an iodine preparation, however, is not as sensitive as examining a Giemsa stained smear, especially when the inclusion bodies are few.

### Immunological detection of chlamydial antigen in genital specimens

Immunological tests using monoclonal antibody to detect *C. trachomatis* antigen include direct fluorescence techniques (FAT), enzyme immunoassays (EIA) and rapid immunochromatographic (IC) techniques. FAT and EIA (microtitration plate format) are mainly performed in specialist reference laboratories. Most membrane EIA and IC tests are sensitive and specific, simple to perform and read with built-in controls, have a shelf-life of 12–18 months, and are suitable for testing individual samples in district laboratories.

### Recently developed rapid IC *Chlamydia* test

A simple to perform immunochromatographic lateral flow *Chlamydia* test has been developed recently by Cambridge University with the collaboration of the Wellcome Trust. The test detects *Chlamydia* antigen in urine or from a vaginal swab. It takes 25 minutes to perform. The *Chlamydia* test does not need to be refrigerated. Evaluations of the test are underway.

#### Availability

Countries in Africa and Asia can obtain the new *Chlamydia* test from Diagnostics for the Real World (see Appendix 11). Further information can be obtained from Dr Helen Lee, e-mail hl207@cam.ac.uk.

#### FURTHER INFORMATION

**Sanders C.** *Chlamydia trachomatis* sexually transmitted infection and diagnostic detection. *The Biomedical Scientist*, pp. 1292–1295. December, 2004.

## FUNGAL PATHOGENS

The basic features and classification of fungi of medical importance are described at the end of subunit 7.2.

### 7.18.38 Dermatophytes (ringworm fungi)

#### Pathogenicity

Ringworm is caused by dermatophyte moulds of the genera *Microsporum*, and *Trichophyton* and species

*Epidermophyton floccosum*. Clinically, ringworm is often referred to as tinea and the locations involved are usually the surface of the body (tinea corporis), the scalp (tinea capitis), the foot (tinea pedis, or athlete's foot) and the nails (tinea unguium, or onychomycosis).

#### Common cause of ringworm in tropical countries

- Ringworm of the body: *M. canis*, *T. verrucosum*, *T. rubrum*, *T. violaceum*, *T. soudanense* (tropical Africa only, face and neck are common sites), *T. concentricum* (South Pacific, Southeast Asia, Central and South America, produces large concentric lesions). *E. floccosum* and *T. rubrum* are common causes of ringworm of the groin.
- Ringworm of the scalp: *M. audouinii* (especially in children), *M. canis*, *T. violaceum* (causes 'black dot' tinea capitis), and *T. schoenleinii* which causes favus in which large crusts form over the scalp, matting hair and often permanent hair loss. Other species also infect the scalp.
- Ringworm of the feet: *T. rubrum*, *T. mentagrophytes*.
- Ringworm of the nails *T. rubrum*, *T. mentagrophytes*, and occasionally other species.

**HIV/AIDS:** *Tinea* infections, often atypical, are common in those with HIV infection. Widespread symmetrical scaly plaques with raised edges are frequently present. Tinea of the scalp (normally seen in children) may be seen in adults co-infected with HIV.

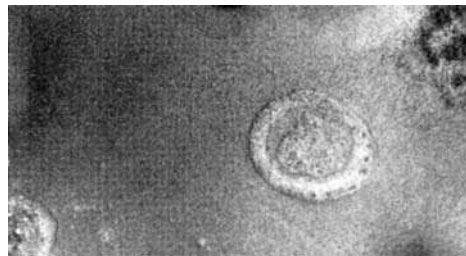

Plate 7.35 Typical ringworm lesion.

Ringworm is contagious. Infections are acquired from active ringworm lesions on humans (anthropophilic), animals (zoophilic) or sometimes from soil (geophilic). The fungus settles on the skin, germinates and forms a mass of branching hyphae, which grows out radially to produce circular lesions (see Plate 7.35). Ringworm fungi infect only the keratinized layers of the skin, hair, and nails. Some

infections cause marked inflammation, e.g. tinea caused by *T. soudanense* and *T. verrucosum* and secondary bacterial infection may occur. Some infections such as those caused by *T. rubrum* tend to be chronic and do not respond well to treatment.

**Chart 7.15 Sites infected by ringworm species**

Species	Skin	Nail	Feet	Scalp
<i>M. audouinii</i> <sup>1</sup>				•
<i>M. canis</i>	•			•
<i>M. ferrugineum</i>	•			•
<i>M. gypseum</i>	•			•
<i>T. mentagrophytes</i>	•		•	•
<i>T. interdigitale</i>		•	•	
<i>T. rubrum</i> <sup>2</sup>	•	•	•	
<i>T. schoenleinii</i> <sup>4</sup>				•
<i>T. soudanense</i> <sup>3</sup>	•			•
<i>T. tonsurans</i> <sup>5</sup>				•
<i>T. verrucosum</i>	•			•
<i>T. violaceum</i>	•			•
<i>T. concentricum</i> <sup>6</sup>	•			
<i>E. floccosum</i> <sup>7</sup>	•		•	

**Notes:**

- 1 Common cause of scalp ringworm in young children.
- 2 Infections often chronic, not responding to treatment. Often found in those with HIV infection.
- 3 Face and neck commonly infected, lesions are inflammatory.
- 4 Causes favus.
- 5 Causes black dot tinea capitis.
- 6 Forms large lesions.
- 7 Groins and thighs are common sites of infection.

## LABORATORY FEATURES

The direct microscopical examination of skin scales, crusts, nail pieces, or hair is the recommended method of diagnosing ringworm. Culture is required when needing to identify the infecting dermatophyte.

**Note:** Up to 10–20% of specimens from ringworm lesions which show fungi microscopically are negative on culture due to the material collected being non-viable.

### Collection of specimens

- 1 Cleanse the affected area with 70% v/v ethanol.
- 2 Collect skin scales, crusts, pieces of nail or hairs

on a clean piece of paper about 5 cm square (use dark coloured paper so that the specimen is easy to see).

**Skin scales:** Collect by scraping the surface of the margin of the lesion using a sterile blunt scalpel.

**Crusts:** Collect by removing part of the crust nearest to healthy skin using sterile scissors and tweezers.

**Nail pieces:** Collect by taking snippings of the infected part of the nail using sterile scissors. Where the nail is thickened, also collect scrapings from beneath the nail.

**Hairs:** Collect by removing dull broken hairs from the margin of the lesion using sterile tweezers or scraping the scalp with a blunt scalpel.

When available, use a Wood's light (filtered UV light) to examine the hair. *Microsporum* infected hairs fluoresce (see later text).

- 3 Fold the paper to enclose the specimen and use a paper clip to close it. Label it with the patient's name and number, source of material, and the date.

### Transporting fungal specimens to a mycology laboratory

Ringworm specimens are best transported in paper packages (rather than screw-cap containers) to reduce humidity and the multiplication of bacteria. Spores of ringworm fungi resist drying and remain viable for several months when stored in paper.

**Caution:** Ringworm specimens are not very infectious but the hands should always be washed with soap and water after collecting specimens.

### Microscopical examination of specimens

Fungi are usually larger than bacteria, and in material from skin, hair, or nails, they can be seen by direct microscopy provided the material is first softened and cleared with a strong alkali such as (20% w/v) potassium hydroxide (KOH). The purpose of the alkali is to digest the keratin surrounding the fungi so that the hyphae and conidia (spores) can be seen.

#### Use of dimethylsulphoxide-KOH reagent

The addition of dimethylsulphoxide (DMSO) to KOH (Reagent No. 32) enables specimens to be examined immediately or after only a few minutes.

- 1 Place a drop of potassium hydroxide solution (Reagent No. 69) on a slide.

**Caution:** The KOH reagent is corrosive, therefore handle it with care.

**KOH with blue-black fountain pen ink added**

This is preferred by some workers, but the ink is not specific for fungi; it also stains cells and other components in the skin. The addition of ink is recommended when *Malassezia furfur* is suspected (see subunit 7.18.39).

- Transfer the specimen (small pieces) to the drop of KOH, and cover with a cover glass. Place the slide in a petri dish, or other container with a lid, together with a damp piece of filter paper or cotton wool to prevent the preparation from drying out.

*Note:* To assist clearing, hairs should not be more than 5 mm long, and skin scales, crusts and nail snips should not be more than 2 mm across.

**Clearing times when using KOH without DMSO**

Hairs clear within 5–10 minutes. Skin scales and crusts usually take 20–30 minutes. Pieces of nail, however, may take several hours to clear.

Clearing can be hastened by *gently* heating the preparation over the flame of a spirit lamp or pilot flame of a Bunsen burner, taking care to prevent drying or splatter of the corrosive KOH solution. Whenever possible reduce the clearing time by using a KOH-DMSO reagent (see above text).

- As soon as the specimen has cleared, examine it microscopically using the 10× and 40× objectives with the condenser iris diaphragm *closed sufficiently to give good contrast*.

*Important:* If too intense a light source is used the contrast will not be adequate and the unstained fungi will not be seen.

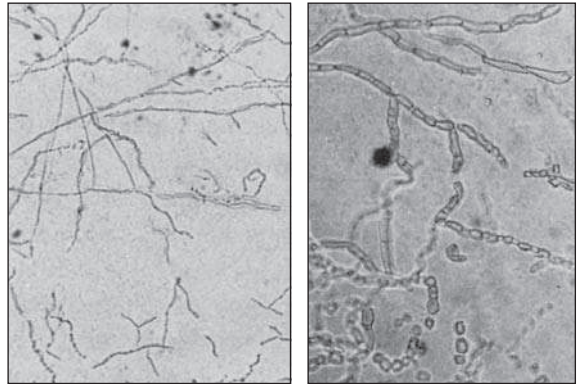

Plate 7.36 *Left:* Fungal hyphae in a potassium hydroxide (KOH) preparation of skin scales as seen with the 10× objective. The KOH has cleared the epithelial cells. *Right:* Hyphae and arthroconidia as seen with the 40× objective.

*Plates reproduced from Isolation and Identification of Ringworm Fungi with the permission of the Controller of Her Majesty's Stationery Office.*

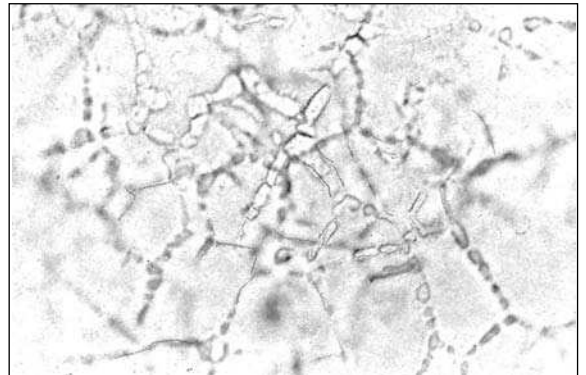

Plate 7.37 Intracellular cholesterol in epidermal cells ('mosaic fungus').

*Reproduced from Isolation and Identification of Ringworm Fungi with the permission of the Controller of Her Majesty's Stationery Office.*

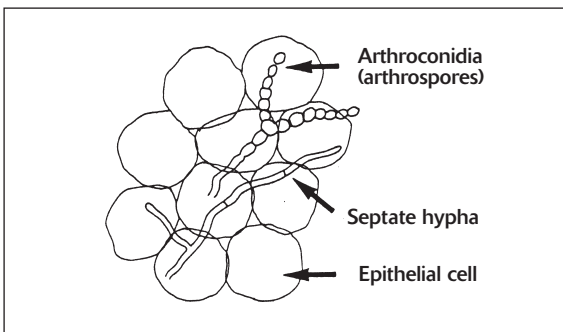

Fig 7.32 Fungal hyphae and arthroconidia in epidermal cell.

**Dermatophytes in skin scales, crusts, nails:**

Look for branching septate hyphae with angular or spherical arthroconidia (arthrospores), usually in chains as shown in Plate 7.36. All species of ringworm fungi have a similar appearance.

*Important:* Ringworm fungi need to be distinguished from epidermal cell outlines, elastic fibres, and artefacts such as intracellular cholesterol ('mosaic fungus'), see Plate 7.37) and strands of cotton or vegetable fibres. Ringworm fungal hyphae can be differentiated from these structures by their *branching, uniform width, and cross-walls (septa)* which can be seen when using the 40× objective.

**Dermatophytes in infected hair:** Look for arthroconidia and hyphae, and note whether the infection is on the outside of the hair (ectothrix) or within it (endothrix). Only a few hyphae may be seen.

*Ectothrix infection:* The arthroconidia may be arranged along the length of the hair in chains as shown in Plate 7.38 or they may be found in masses around the hair as shown in Plate 7.39.

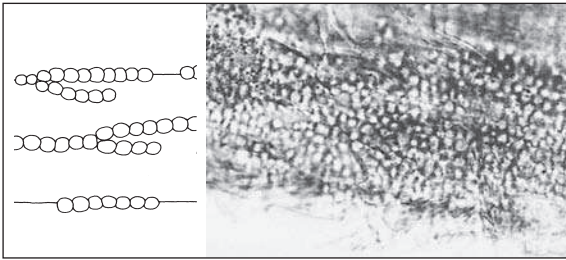

Plate 7.38 Ectothrix dermatophyte infection of hair showing arthroconidia arranged in linear chains.

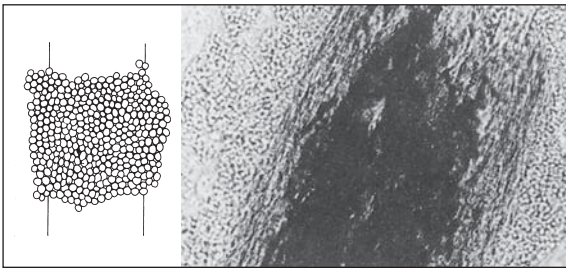

Plate 7.39 Ectothrix dermatophyte infection of hair showing arthroconidia massed together.

*Endothrix infection:* Look for infection in the hair substance as shown in Plate 7.40.

A special type of endothrix infection is shown by *T. schoenleinii*, the dermatophyte that causes favus. *T. schoenleinii* hyphae do not break up into arthroconidia but eventually die leaving characteristic air spaces as shown in Plate 7.41.

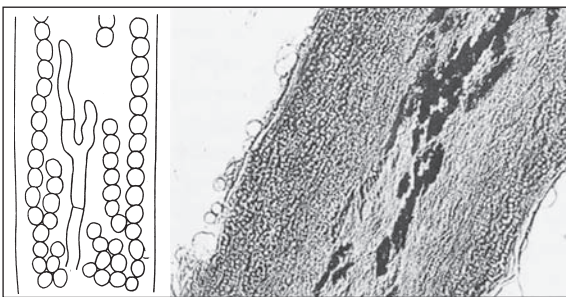

Plate 7.40 Endothrix dermatophyte infection of hair.

*Acknowledgement:* Plates 7.38–7.41 are reproduced from *Isolation and Identification of Ringworm Fungi with the permission of the Controller of Her Majesty's Stationery Office.*

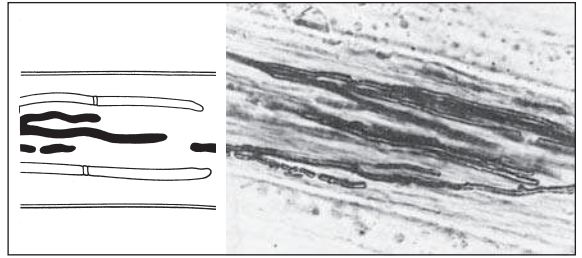

Plate 7.41 Endothrix favic hair.

The types of hair infection caused by the different species of *Microsporum* and *Trichophyton* are summarized in the following chart:

**Chart 7.16 Infections caused by hair ringworm fungi**

<b>Ectothrix</b> 2–5 µm: arthroconidia massed	<i>M. audouinii</i> <sup>1</sup> <i>M. canis</i> <sup>1</sup> <i>M. ferrugineum</i> <sup>1</sup>
2–5 µm: arthroconidia in chains	<i>T. mentagrophytes</i>
5–8 µm: arthroconidia massed or in chains	<i>M. gypseum</i>
8–10 µm arthroconidia in chains	<i>T. verrucosum</i>
<b>Endothrix</b> 4–8 µm: arthroconidia in chains	<i>T. soudanense</i> <i>T. tonsurans</i> <i>T. violaceum</i>
<b>Favic</b> Only hyphae	<i>T. schoenleinii</i> <sup>2</sup>

- 1 Hair shafts fluoresce bright yellow-green under UV (Wood's light).
- 2 Hair shafts fluoresce dull green along their lengths under UV (Wood's light).

**Note:** *T. rubrum* and *E. floccosum* do not infect hair.

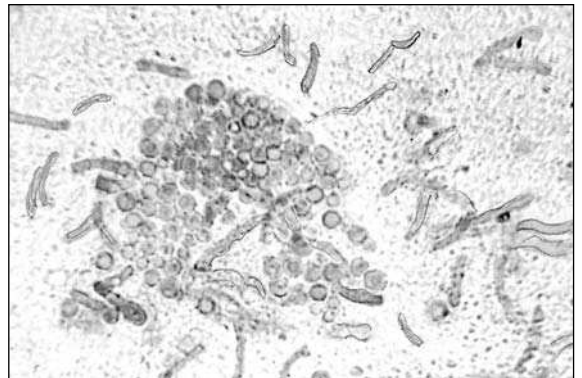

Plate 7.42 *Malassezia furfur* yeast cells and hyphae in KOH blue-black ink preparation. (see also colour Plate 69).

### Culture of dermatophytes

Culture is needed to identify the species of ringworm fungus. This is best carried out in a mycology laboratory. The species of dermatophyte is identified from the colonial appearance of the culture and by examining the mycelial growth microscopically for specialized hyphae such as spiral, pectinate or antler hyphae, presence or absence and morphology of macroconidia, microconidia, and chlamydospores. The addition of actidione to culture media inhibits environmental fungi but not dermatophytes.

## 7.18.39 *Malassezia furfur*

### Pathogenicity

*M. furfur* is the cause of pityriasis versicolor, a chronic but not usually serious infection of the skin. More widespread infections are reported in those with HIV infection. It is very common in warm humid countries. Infected areas are recognized by their depigmentation and scaling. The lesions fluoresce yellow-orange under UV light (Wood's light).

*M. furfur* can be mould or yeast-like. Both forms may co-exist, therefore *M. furfur* is not a truly dimorphic fungus.

*M. furfur* is easily recognized in a KOH preparation of skin scrapings with 20% blue-black ink added.

***M. furfur* yeasts:** Look for clusters of round or oval thick-walled budding yeast cells about 6 µm in diameter, and abundant short curved septate hyphae (pseudo-hyphae) of various sizes and shapes as shown in Plate 7.42 and colour Plate 69. The yeast cells and hyphae also stain by the Gram technique.

*Note:* Cultural techniques are not appropriate for the diagnosis of pityriasis versicolor.

## 7.18.40 Fungi that cause chromoblastomycosis

### Pathogenicity

Chromoblastomycosis is caused by pigmented (dermatiaceous) moulds of the species *Phialophora*, *Fonsecaea* and *Cladosporium carrionii*, and *Rhinocladiella aquaspersa*.

Chromoblastomycosis (chromomycosis) is a

chronic warty mycosis of the skin and subcutaneous tissues. The lesions are usually on the lower leg and foot ('mossy foot'), but other parts of the body can also be affected. The disease is found especially in tropical Africa, central and northern South America (in areas of high rainfall).

Chromoblastomycosis can be diagnosed microscopically by examining a KOH preparation of crusts, skin scales, and exudates for sclerotic yeast cells.

**Sclerotic cells:** Look for pale to dark brown thick walled spherical bodies measuring 5–10 µm or more in diameter. They often show transverse divisions (see Plate 7.43). In crusts and scales, dark-coloured branching septate hyphae may also be seen.

Sclerotic bodies can also be found in biopsies. Culture (in a mycology laboratory) is necessary to identify the different species. Identification is based on the type of conidiophore produced. Most species are slow-growing.



Plate 7.43 Sclerotic cells in KOH preparation.

## 7.18.41 Fungi and actinomycetes\* causing mycetoma

\*Actinomycetes, although bacteria are described in this subunit because they require differentiation from the fungi that cause mycetoma.

### Pathogenicity

The common species of fungi and actinomycetes that cause mycetoma in tropical countries are listed in Chart 7.17.



**Mycetoma**

Mycetoma is a chronic granulomatous disease of the subcutaneous and deep tissues. Progressive destruction of tissue leads to loss of function of the affected site. The foot is commonly affected (Madura foot) but other parts of the body can also be involved including the hands, head, thigh, and wall of the chest.

The mycetoma swelling is nodular and contains sinuses. Mucopus containing small grains, or granules (colonies), is discharged through sinuses which open on the surface of the skin. When the mycetoma is caused by a fungus, the swelling is called a eumycetoma, and when caused by an actinomycete it is called an actinomycetoma.

**Further information:** Readers are referred to the mycetoma website [www.mycetoma.org](http://www.mycetoma.org).

*Important:* Actinomycetomas usually respond to treatment with antibiotics and sulphonamides whereas mycetoma caused by fungi are resistant to most antimicrobials. It is therefore important for the laboratory to differentiate between fungal and bacterial causes of mycetoma.

**Chart 7.17 Actinomycetes and fungi causing mycetoma**

FUNGI		
Species	Distribution	Granule
<i>Madurella mycetomatis</i>	Tropical Africa India, S. America, Madagascar, Indonesia	Dark red to black hard, 1–5 mm
<i>Madurella grisea</i>	Mainly South and Central America, Caribbean	Black, hard, 1–2 mm
<i>Exophiala jeanselmei</i>	Tropics	Black, soft, below 0.5 mm
<i>Leptosphaeria senegalensis</i>	Tropics and subtropics	Black, elongate, hard, 0.5–2 mm
<i>Pseudallescheria boydii</i>	Africa	White, soft, up to 1 mm
<i>Aspergillus nidulans</i>	Sudan and elsewhere	White-yellow, soft, 1–2 mm

ACTINOMYCETES		
Species	Distribution	Granule
<i>Actinomadura madurae</i>	India, Ethiopia, Somalia, Argentina, Brazil, Middle East	White-yellow or pink, soft, about 2 mm
<i>Actinomadura pelletieri</i>	Sudan, Senegal, Nigeria, India, South America	Red, firm, about 0.5 mm
<i>Streptomyces somaliensis</i>	Somalia, Ethiopia, Sudan, Egypt, West Africa, Brazil	White-yellow hard, 1–2 mm
<i>Nocardia brasiliensis</i>	Brazil, Venezuela, Mexico	White-yellow, soft up to 0.5 mm

**LABORATORY FEATURES**

The colour, size, consistency and microscopical appearance of granules are used to diagnose and

differentiate mycetomas. Black granules indicate a fungal infection, red granules an actinomycetic infection, and pale coloured granules are produced by both fungi and actinomycetes.

**Collection of specimen (mucopus)**

- 1 Using a sterile hypodermic needle, lift up the crusty surface over a sinus opening.
- 2 Transfer a sample of the draining granular mucopus to a slide.
- 3 Add a drop of distilled water or saline, and examine for granules (a magnifying glass will help to detect very small granules).
- 4 Note the colour, size, and shape of the granules, and whether they are hard or soft when held between forceps (see Chart 7.17).

**Microscopical examination of granules**

- 1 Crush a few of the granules in a small amount of distilled water, and spread the contents on two slides, to make *thin* preparations.
- 2 To one preparation, add one or two drops of potassium hydroxide (KOH) solution (Reagent No. 69), and leave for 5–10 minutes.  
Allow the other preparation to dry, and fix by covering with methanol for 2–3 minutes (Gram stain if indicated after examining KOH preparation).
- 3 Examine the KOH preparation microscopically using the 10× and 40× objectives with the condenser iris diaphragm *closed sufficiently to give good contrast*.

**Differentiating between fungal and bacterial causes of mycetoma**

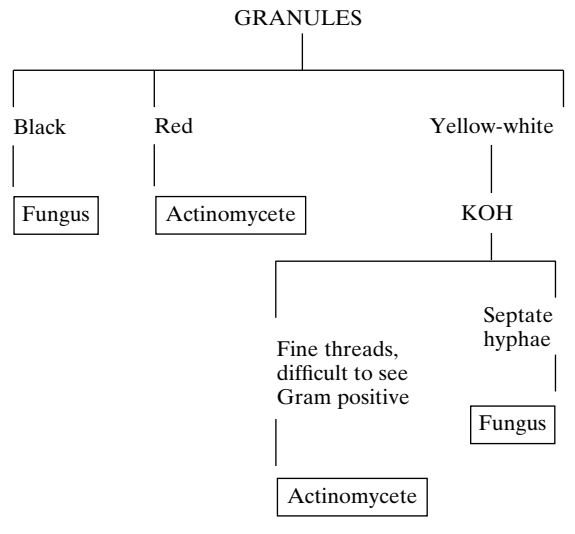

**Fungal hyphae:** Look for branching intertwining septate hyphae, measuring 4–8  $\mu\text{m}$  in diameter. The hyphae of the pigmented species (black granule fungi) are dark coloured. Chlamydo spores are frequently seen. The hyphae do not stain by the Gram technique.

**Actinomycetes:** In unstained KOH preparations, the very thin (1  $\mu\text{m}$  diameter) often fragmented filaments of actinomycetes are difficult to see. They are best detected in a Gram stained preparation. They appear as Gram positive branching filaments (see Plate 7.44 and colour Plate 59). The branches of *N. brasiliensis* are acid fast.

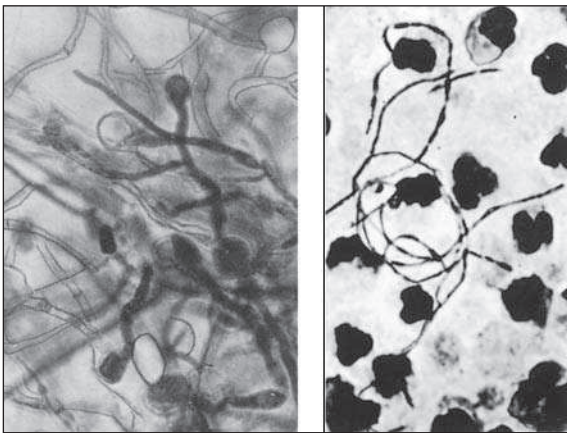

Plate 7.44 Left: Fungal hyphae with chlamydo spores. Right: Gram positive actinomycetic filaments (See also colour Plate 59).

## 7.18.42 Fungi that cause subcutaneous zygomycosis, rhinosporidiosis, sporotrichosis

### Subcutaneous zygomycosis

In tropical countries, subcutaneous zygomycosis (phycomycosis) is caused mainly by *Basidiobolus* species. It is seen mainly in tropical Africa, commonly affecting children.

The disease takes the form of hard swellings in subcutaneous tissue with chronic inflammation. The trunk and lower parts of the body are most affected.

*Basidiobolus* species are zygomycetes, (see end of subunit 7.2), producing aseptate hyphae. The large ribbon-like hyphae without septa (or occasional septate hyphae) can be seen microscopically in KOH

preparations of infected tissue, but the diagnosis, is best made by examining a biopsy for granuloma and the presence of aseptate hyphae, eosinophils, neutrophils, and fibroblasts. Biopsies (about 5 mm in diameter) should be fixed in formol saline (Reagent No. 38) and sent to a histopathology laboratory for processing and reporting.

### Rhinosporidiosis

*Rhinosporidium seeberi* causes rhinosporidiosis, a chronic granulomatous mycosis in which polyps form in the mucous membranes of the nose, nasopharynx and soft palate. Occasionally the eye and other parts of the body are also affected. The disease is found in India, Sri Lanka, and parts of Indonesia, Philippines, Malaysia, Central and South America.

The laboratory diagnosis of rhinosporidiosis is usually made by examining a biopsy for sporangia of *R. seeberi* containing sporangiospores in different stages of growth. The biopsy should be fixed in formol saline (Reagent No. 38) and sent to a histopathology laboratory for processing and reporting.

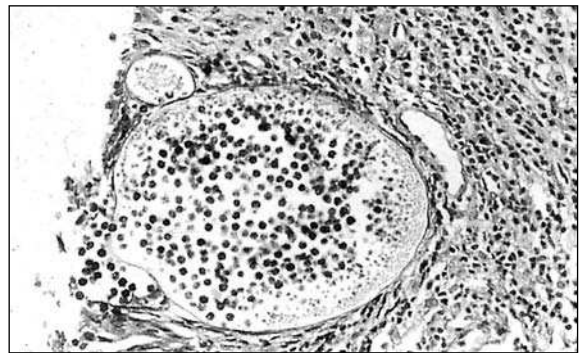

Plate 7.45 Sporangium of *Rhinosporidium seeberi* in a haematoxylin and eosin stained preparation as seen with the 40 $\times$  objective. Courtesy of Professor DWR Mackenzie.

### Sporotrichosis

*Sporothrix schenckii* causes sporotrichosis, a widespread mycosis in tropical countries. It may cause a cutaneous infection, often showing lymphatic spread or occasionally a deep mycosis (affecting lungs, joints, meninges). Disseminated cutaneous infections with nodules and ulcers often occur in AIDS patients and others with immunosuppression. Infections require differentiation from leishmaniasis.

*S. schenckii* is a dimorphic fungus. The direct examination of crusted scales, pus, or sputum may show



yeast cells but often they are too few to be detected. The yeasts are small (2–6 µm), ovoid or elliptical bodies, sometimes showing budding.

Sporotrichosis is best diagnosed by culturing specimens (in a mycology laboratory) taken from the edge of lesions and examining the mycelia microscopically for septate hyphae and conidia. The mould form is obtained when the culture is incubated at 20–30°C.

### 7.18.43 *Histoplasma species*

#### Pathogenicity

Histoplasmosis is caused by *Histoplasma capsulatum* (classical or small form) and *Histoplasma duboisii* (African or large form).

**Terminology:** The complete species names are *Histoplasma capsulatum* var *capsulatum* and *Histoplasma capsulatum* var *duboisii*.

*H. capsulatum* infection occurs worldwide including tropical countries. It may be asymptomatic, acute, or chronic. The acute pulmonary form produces symptoms similar to pneumonia whereas the chronic form resembles pulmonary tuberculosis. Disseminated *H. capsulatum* infections are rare, occurring mostly in infants and patients with depressed cellular immune responses, e.g. patients with AIDS.

*H. duboisii* occurs in tropical Africa. It is often referred to as large-cell histoplasmosis because the intracellular yeast forms are three to four times larger than *H. capsulatum*. Infection with *H. duboisii* may take the form of a localized skin nodule which may ulcerate, bone abscess, or a generalized infection. The lungs are only occasionally infected. Severe infections have been reported in those co-infected with HIV.

#### LABORATORY FEATURES

*H. capsulatum* and *H. duboisii* are dimorphic fungi with the yeast forms occurring in tissues. *Histoplasma* yeast forms can be found in sputum (*H. capsulatum*), in pus from lesions (*H. duboisii*), or in bone marrow aspirates, blood buffy coat preparations and blood cultures, in generalized infections.

The yeasts can be seen in the cytoplasm of endothelial and mononuclear cells in Giemsa stained preparations. When facilities for fluorescence microscopy are available, the yeasts are easily seen in a calcofluor white preparation.

***H. capsulatum* yeasts:** Look for small round or oval cells, measuring 1–4 µm in diameter (see Plate 7.46). They require differentiation from the amastigotes of *Leishmania donovani* which can also be found in mononuclear cells.

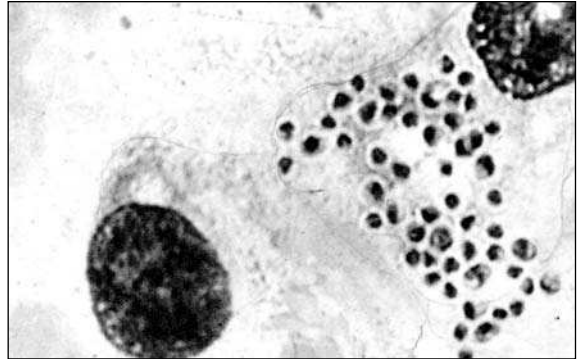

Plate 7.46 *Histoplasma capsulatum* in a macrophage as seen with the 100× objective (Giemsa stained preparation).

***H. duboisii* yeasts:** Look for large round to oval cells measuring 7–15 µm in diameter (see Plate 7.47). The cells may appear nucleated. Usually many yeasts are found.

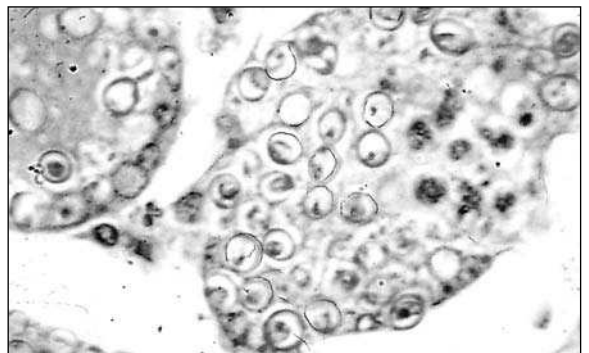

Plate 7.47 Intracellular *Histoplasma duboisii* yeast cells in a Giemsa stained preparation as seen with the 100× objective. Courtesy of Professor DWR Mackenzie.

**Culture:** *Histoplasma* produces mycelial growth with characteristic warty conidia when cultured at room temperature (in a mycology laboratory with facilities for the safe handling of cultures). Small microconidia and characteristic large, round, spiny macroconidia are produced. At 37°C on certain media it is possible to induce the yeast phase of this dimorphic fungus.

### 7.18.44 *Blastomyces dermatitidis*

#### Pathogenicity

*B. dermatitidis* causes blastomycosis. Although formerly thought to occur only in North America, in recent years blastomycosis has been recognized in tropical and subtropical African countries, India, and the Far East.

Following inhalation of spores, *B. dermatitidis* can cause chronic lung disease resembling pulmonary tuberculosis. Occasionally, an infection spreads to the central nervous system, urogenital system, bone, subcutaneous tissues, and the skin. Cutaneous infections can lead to ulceration or warty granuloma.

*B. dermatitidis* is a dimorphic fungus with a yeast form in tissues. The yeasts can be detected microscopically in pus, sputum and other specimens. A lactophenol cotton blue preparation (Reagent No. 46) is useful because it stains the yeasts blue.

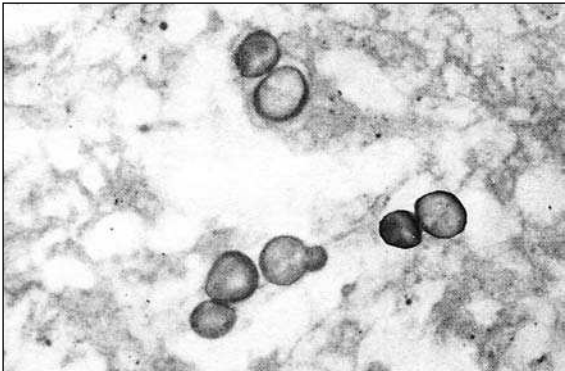

Plate 7.48 Yeast cells of *Blastomyces dermatitidis* in KOH preparation.

***B. dermatitidis* yeasts:** Look for large, round, thick-walled yeasts measuring 5–15  $\mu\text{m}$  in diameter. The cells show single budding as shown in Plate 7.48.

### 7.18.45 *Paracoccidioides brasiliensis*

#### Pathogenicity

*P. brasiliensis* causes paracoccidioidomycosis, a systemic mycosis that is found in Brazil, and also in

other South American countries and Central America.

*P. brasiliensis* infects the mucous membranes of the mouth and nose where it causes painful ulcerative granulomas with destruction of nasal and mouth tissue. The lymph glands of the neck may also become involved and the infection can then spread by way of the lymphatic system to the lungs, spleen, and other organs of the body.

*P. brasiliensis* is a dimorphic fungus with a yeast form in tissue. The yeasts can be detected microscopically in preparation of infected tissue, exudate, lymph gland aspirate, or other specimen. They stain well with lactophenol cotton blue (Reagent No. 46).

***P. brasiliensis* yeasts:** Look for round to oval large yeasts, measuring 10–40  $\mu\text{m}$ . Unlike *B. dermatitidis*, the yeasts of *P. brasiliensis* show multiple budding around the parent cell as shown in Plate 7.49.

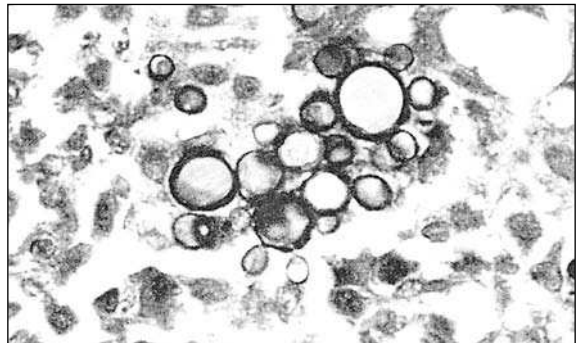

Plate 7.49 *Paracoccidioides brasiliensis* yeast cells showing multiple peripheral budding as seen with the 100 $\times$  objective. Courtesy of Dr Hay.

### 7.18.46 *Coccidioides immitis*

#### Pathogenicity

*C. immitis* causes coccidioidomycosis. The disease is endemic in semiarid regions of Central America, South America and southwestern USA but has occasionally been reported elsewhere. The fungus is found in the soil. Infection with *C. immitis* is often self-limiting or it can lead to serious progressive pulmonary disease, meningitis, and disseminated infection in skin and bones, particularly in those with immunosuppression.

*C. immitis* is a dimorphic fungus with a spherule form in tissues. It can be detected microscopically in sputum, pus, pleural fluid, tissue specimens and

occasionally in c.s.f. The finding of spherules is diagnostic of coccidioidomycosis. A marked eosinophilia is a common finding.

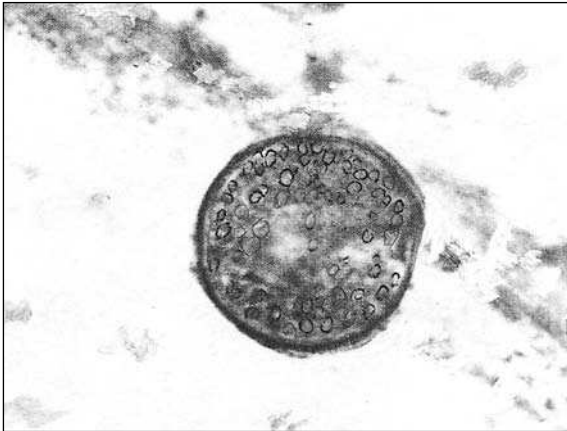

Plate 7.50 Thick-walled spherule containing endospores as seen with the 100× objective.

***C. immitis* spherules:** Look for large thick-walled spherical cells of various sizes (20–200 µm in diameter) containing small endospores or granular material (see Plate 7.50).

*C. immitis* can also be cultured but this *must* only be carried out in a mycology laboratory with facilities for the safe handling of cultures. The arthroconidia produced by *C. immitis* moulds are highly infectious. Serological tests have been developed for diagnosing coccidioidomycosis.

## 7.18.47 *Candida albicans*

### Pathogenicity

*Candida albicans* is the commonest cause of candidiasis (moniliasis). The yeast is a common commensal of the gastrointestinal tract. Most *Candida* infections are opportunistic, occurring in debilitated persons. Candidiasis is also associated with prolonged broad-spectrum antibiotic therapy.

Many different clinical forms of candidiasis are known, involving primarily the mucosal surfaces (thrush), gastrointestinal or urogenital tract, and deep-seated infections such as candidaemia or meningitis. *Candida* vaginitis is a common infection during pregnancy. *Candida* infections of the mouth and oesophagus are common in those with HIV disease.

*Candida* yeast cells can be detected in unstained wet preparations or Gram stained preparations of skin, urine, vaginal discharge or other exudates from mucosal surfaces.

***Candida* yeasts:** They are small, oval, measuring 2–4 µm in diameter. Single budding of the cells may be seen (see Plate 7.51). In stained smears, the yeasts can often be seen attached to pseudohyphae. Both the yeasts and pseudohyphae are Gram positive (see colour Plate 72).

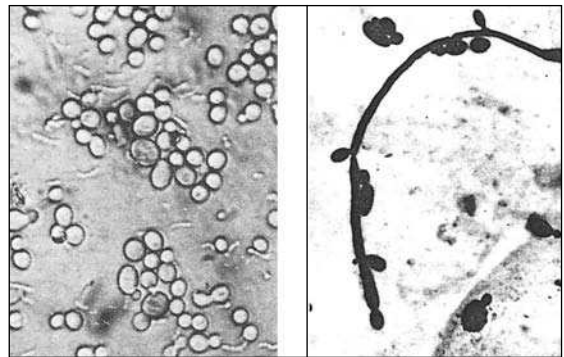

Plate 7.51 *Left: C. albicans* yeasts in wet unstained preparation. *Right: Gram stained preparation showing Gram positive C. albicans* yeasts and pseudohyphae (see also colour Plate 72).

### Cultural identification of *C. albicans*

*C. albicans* grows well on Sabouraud agar and most routinely used bacteriological media. Cream coloured pasty colonies usually appear after 24–48 hours incubation at 35–37°C. The colonies have a distinctive yeast smell and the budding cells can be easily seen by direct microscopy in stained or unstained preparations.

On agar to which corn meal extract has been added, *C. albicans* can be identified by the formation of pseudohyphae and chlamydoconidia. *C. albicans* can be identified presumptively by a simple germ tube test.

#### Germ tube test to identify *C. albicans*

- 1 Pipette 500 µl (0.5 ml) of human or preferably bovine or rabbit serum into a small test tube.
- 2 Using a sterile wire loop, inoculate the serum with a yeast colony from the culture plate. Place the tube in a water bath or incubator at 35–37°C for 2–3 hours.
- 3 Using a Pasteur pipette, transfer a drop of the serum yeast culture to a glass slide, and cover with a cover glass.
- 4 Examine the preparation using the 10× and 40× objectives with the condenser iris diaphragm closed sufficiently

to give good contrast. (If preferred, a drop of lactophenol cotton blue can be added to the preparation to stain the yeast cells.)

- 5 Look for sprouting yeast cells, that is tube-like outgrowths from the cells (known as germ tubes).

When sprouting yeast cells are seen, report the culture as 'C. albicans isolated'.

\*Note: The germ test is also positive with *C. dubliniensis*, a *Candida* species associated with oral thrush in those co-infected with HIV.

## 7.18.48 *Cryptococcus neoformans*

### Pathogenicity

*C. neoformans* causes cryptococcosis, a sporadic or opportunistic yeast mycosis usually affecting the lungs, brain and meninges, and occasionally other parts of the body. As an opportunistic infection, it is particularly associated with HIV infection and diseases of the reticuloendothelial system. In HIV disease, cryptococcal meningitis is often fatal.

### *C. neoformans* variants

There are two variants, *C. neoformans* var. *neoformans* and *C. neoformans* var. *gattii*. The *neoformans* variant causes disease mainly in immunocompromised patients, particularly those with HIV disease. The *gattii* variant is the commonest cause of cryptococcal meningitis in immunocompetent persons. It is found only in the tropics and sub-tropics.

### LABORATORY FEATURES

*C. neoformans* yeast cells can be detected microscopically in sputum, cerebrospinal fluid (c.s.f.), pus, and occasionally in blood cultured from AIDS patients.

Note: The c.s.f. biochemical and cellular findings in cryptococcal meningitis are described in subunit 7.13.

***C. neoformans* yeasts:** Look for single and budding oval or spherical yeast cells of variable size (2–10 µm in diameter) surrounded by a thick capsule (demonstrated in an India ink preparation) as shown in colour Plate 73. Very occasionally the capsule may be absent. Examination of an India ink preparation is described in subunit 7.13.

Note: In cryptococcal meningitis, the yeasts are often first detected in a Gram stained preparation of c.s.f. sediment. They are Gram positive but stain poorly and unevenly (see colour Plate 74). In a Giemsa

stained preparation, the capsule surrounding *C. neoformans* can be seen as a clear unstained area (see colour Plate 75). Centrifugation of the c.s.f. is necessary because the yeasts are often few.

### Culture of *C. neoformans*

On blood agar and Sabouraud agar, *C. neoformans* produces moist white-cream coloured mucoid colonies usually after 2–3 days incubation. When examined microscopically, the yeast cells are capsulated but the capsules are often smaller than when seen in specimens. Occasionally capsules are absent. *C. neoformans* is urease positive. Details of techniques to differentiate *C. neoformans* variants can be found in textbooks of microbiology and mycology.

### Detection of *C. neoformans* antigen

Soluble (free) antigen derived from capsular material can be detected in c.s.f. and serum using latex particles or staphylococcal cells coated with anti-cryptococcal immunoglobulin (COAG test). Up to 90% of patients with cryptococcal meningitis give a positive c.s.f. antigen result. Detection of serum cryptococcal antigen is a sensitive method of diagnosing cryptococcosis in patients with AIDS. The sensitivity and specificity of cryptococcal antigen tests have increased by the inclusion of pronase in the reagent.

Test kits are available from several manufacturers including Bio-Rad Laboratories and Immuno-Mycologics (see Appendix 11). The tests, however, are expensive.

## 7.18.49 *Aspergillus* species

### Pathogenicity

*Aspergillus* species are saprophytic moulds. Most live in the environment without causing disease. *Aspergillus fumigatus* is the commonest human pathogen. Other species causing infection include *A. niger* and *A. flavus*. *A. nidulans* is one of the fungi that can cause mycetoma (see subunit 7.18.41).

Diseases caused by *Aspergillus* include allergic bronchopulmonary aspergillosis (causing asthma and eosinophilia) due to hypersensitivity to aspergillus antigen inhaled in airborne conidia, aspergilloma in which inhaled conidia germinate in a pulmonary cavity and grow into a 'fungus ball', and invasive aspergillosis in which the fungus infects the lung (causing acute pneumonia) and spreads to other organs, producing abscesses and necrotic lesions.

Invasive aspergillosis occurs mainly in immunocompromised patients, and is often life-threatening. *Aspergillus* infection of nasal sinuses is very common in some parts of the world, e.g. Indian sub-continent. *Aspergillus* species can also cause superficial infections of the external ear and occasionally infect the eye. Serious toxic symptoms and hepatic disease can be caused by ingesting peanuts, corn, grains, and other food contaminated with aflatoxin produced by *A. flavus*.

### LABORATORY FEATURES

The hyphae of *Aspergillus* can be detected microscopically in a KOH or calcofluor white (fluorescence microscopy) preparation of sputum in aspergilloma and invasive aspergillosis. The sputum may contain blood. The typical *Aspergillus* fruiting head showing a conidiophore, swollen vesicle, phialides, and radiating chains of conidia is formed in cultures and is not often seen in uncultured specimens. Paranasal biopsy specimens will show the fungus microscopically and by culture.



Plate 7.52 *Aspergillus* septate hyphae with V-shaped branching in KOH preparation as seen with the 100× objective (see also colour Plate 70).

***Aspergillus* hyphae:** Look for hyaline septate hyphae of uniform width (about 4 µm) with V-shaped branching (45° angle) as shown in Plate 7.52. The finding of such hyphae (often in abundance) is indicative of aspergillosis. In aspergilloma, the hyphae may be few and short in length. When hyphae are not seen in the KOH preparation, examine a Gram stained smear. The hyphae are Gram positive as shown in colour Plate 70.

*Note:* The culture of specimens from patients with suspected aspergillosis is best carried out in a mycology laboratory. Antibody tests are useful for

allergic aspergillosis and aspergilloma but are less useful in the diagnosis of invasive aspergillosis.

## 7.18.50 *Penicillium marneffe*

### Pathogenicity

*P. marneffe* is an uncommon pathogen in humans. It has however, been reported as a common opportunistic pathogen causing systemic penicilliosis in AIDS patients in Thailand, Southern China, Hong Kong, Vietnam, and other parts of Southeast Asia. Rodents are natural reservoirs of *P. marneffe* and may be involved in its transmission to humans.

In those co-infected with HIV, *P. marneffe* causes fever, anaemia, weight loss and skin lesions (often molluscum contagiosum-like).

*P. marneffe* is a mould fungus with a yeast form in tissues.

**Yeast cells of *P. marneffe*:** Look for oval-elliptical yeast cells measuring about 4.5 µm in diameter with characteristic septation (dividing line). They can be found in mononuclear cells in Giemsa stained touch smears of skin, lymph node biopsies, or bone marrow smears. The intracellular yeasts are shown in colour Plate 71. They require differentiation from the yeast cells of *Histoplasma* (see subunit 7.18.43) in areas where both fungi occur.

### Culture of *P. marneffe*

After about 4 days incubation on dextrose Sabouraud agar at room temperature, *P. marneffe* produces a folded growth with a grey fluffy mycelium and a characteristic red pigment which also colours the surrounding medium. The edge of the colony (area of new growth) is surrounded by a white margin. Chains of spherical conidia on asymmetrically borne groups of phialides are produced which can be identified microscopically.

## 7.18.51 Fungi that cause mucormycosis

### Pathogenicity

Mucormycosis (zygomycosis) is caused mainly by species of *Absidia*, *Rhizopus*, *Rhizomucor*, and *Mucor*. It is an opportunistic mycosis, causing severe

paranasal, pulmonary or disseminated infections in those with reduced host defences, e.g. patients with uncontrolled diabetes, leukaemia, burns, and those being treated with cytotoxic drugs and corticosteroids.

The hyphae of fungi that cause mucormycosis can be detected microscopically in KOH preparations of exudates from infected lesions or tissue.



Plate 7.53 KOH preparation showing aseptate hyphae of fungi causing mucormycosis.

**Hyphae of zygomycetes:** Look for large ribbon-like (10–30 µm diameter) pieces of *aseptate* hyphae or hyphae with few septa (see Plate 7.53). The hyphae are irregular in width, mainly branch at 90°C, and may appear folded, twisted and distorted.

*Note:* The sporangium head containing sporangiospores is typically seen in cultures. If culture is required, this should be undertaken in a specialist mycology laboratory.

## 7.18.52 *Pneumocystis jiroveci*\*

\*Formerly called *Pneumocystis carinii*

### Pathogenicity

*P. jiroveci* is an opportunistic fungal pathogen, causing life-threatening pneumonia in immunocompromised patients, particularly in AIDS patients not receiving anti-retroviral therapy. Infection probably occurs by inhaling the organism in aerosols. Some infections may also occur from reactivation of a latent infection. *Pneumocystis* pneumonia is an important cause of death in infants born to HIV seropositive mothers.

### LABORATORY FEATURES

Examination of stained preparations of bronchial and alveolar washings (broncho-alveolar lavage), collected using a bronchoscope, is recommended for the detection of *P. jiroveci* cysts. The specimen must contain alveolar exudate if cysts are to be found. In AIDS patients, cysts can often be found also in induced sputum, i.e. specimen collected after the patient has inhaled 3–5% saline mist for about 15 minutes. The hypertonic saline stimulates the coughing up of alveolar mucous material.

### Processing specimen and cyst concentration

- 1 Add a volume of freshly made acetyl-L-cysteine mucolytic reagent (Reagent No. 2) or pancreatin mucolytic reagent (Reagent No. 65) equal to twice the volume of specimen. Mix at intervals until the mucus is completely dissolved.

*Caution:* Specimens may contain *M. tuberculosis*, therefore handle the sputum with care.

- 2 Centrifuge at high speed for 10 minutes to sediment the cysts. Remove and discard the supernatant fluid.
- 3 Add physiological saline (Reagent No. 68) to the sediment, mix well, and re-centrifuge at high speed for 10 minutes. Remove and discard the supernatant fluid.
- 4 Mix the sediment and make two *thin* preparations on slides. Allow the smears to air-dry. Fix with methanol for about 2 minutes.

*Note:* Because of the high prevalence of tuberculosis, prepare also a smear for Ziehl-Neelsen staining to examine for AFB (see subunit 7.3.5).

- 5 Use Giemsa\* to stain one of the smears. Use a 1 in 25 dilution of the stain in pH 6.8 buffered water and follow the staining technique described in subunit 7.3.10.

\*Alternatives to Giemsa are *Diff-Quick* rapid stain or May Grunwald-Giemsa.

- 6 Stain the second smear with toluidine blue-0 stain (see later text for method).

### Staining *P. jiroveci* cysts

Toluidine blue stains the surface (cell wall) of *P. jiroveci* cysts but not the internal structures. Giemsa stains the small internal nucleated bodies of the cysts enabling the cysts to be differentiated from yeast cells which may also be found in specimens.

An alternative staining procedure to toluidine blue-0 is the methenamine-silver borate staining technique, but this is far more complex and requires a range of expensive not easily available reagents in district laboratories. *P. jiroveci* cysts can also be demonstrated by the Papanicolaou staining procedure (mainly used in cytology laboratories).

- 7 Examine the smears microscopically for an adequate length of time (cysts are often few). The cysts occur singly and in clusters.

**Toluidine blue smear:** Use the 10× and 40× objective to detect and examine the cysts (mount the smear under a cover glass using a drop of immersion oil). Look for blue staining spherical cysts about 4–7 µm in diameter or cup-shaped cysts with a collapsed wall as shown in Plate 7.54 and colour Plate 76.

**Giemsa stained smear:** Use the 100× objective to identify the very small purple-mauve intracystic bodies (nuclei of the trophozoites within the cyst). They can be seen in groups, up to eight in number as shown in Plate 7.54 and colour Plate 77. The nuclei are best seen in thin well stained parts of the smear.

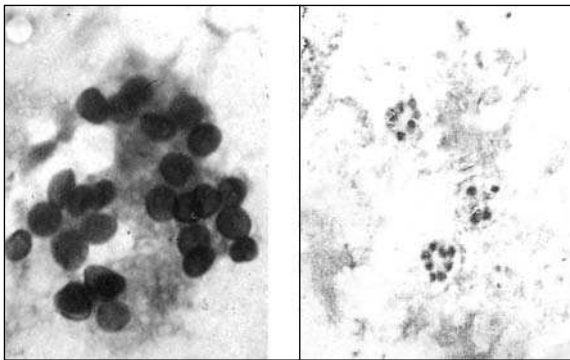

Plate 7.54 *Left:* Toluidine blue O stained cysts of *Pneumocystis jiroveci* as seen with the 40× objective. *Right:* Giemsa stained preparation showing internal nuclei of cysts (up to 8 in number) as seen with the 100× objective (see also colour Plates 76, 77).

#### Staining *P. jiroveci* cysts using toluidine blue-0

The modified technique of Gosey *et al* is recommended. This uses a glacial acid-sulphuric acid reagent to treat the smears prior to staining. This sulphation stage helps to clear background material from the preparation, enabling the cysts to be seen more clearly.

#### Sulphation reagent

Glacial acetic acid ..... 45 ml  
Concentrated sulphuric acid ..... 15 ml

**Caution:** Both the above reagents are harmful and corrosive with irritating vapours, therefore handle them with great care, wearing protective gloves. When the sulphuric acid is added to the acetic acid, considerable heat is produced, therefore immerse the coplin jar in cold water. See also subunit 3.5 in Part 1 of the book for safety procedures to follow when handling dangerous acids.

- Pour the glacial acetic acid into a coplin jar (immersed in cold water).
- Slowly add the concentrated sulphuric acid and mix with a glass rod. Label and store at room temperature. In a sealed coplin jar, the sulphation reagent can be used for up to 1 week.

#### Toluidine blue-0

Toluidine blue-0 (TBO) ..... 0.3 g  
Concentrated hydrochloric acid ..... 2.0 ml  
Absolute ethanol (or methanol) ..... 140 ml  
Distilled water ..... 60 ml

- Dissolve the TBO powder in the distilled water.
- With care, add the hydrochloric acid and mix.
- Add the ethanol or methanol and mix well. Label and store the stain at room temperature. It can be kept for up to 1 year.

#### Decolorizer

Use 95% v/v ethanol or 95% v/v methanol

#### Method

- 1 Immerse the methanol fixed smear and control smear in the sulphation reagent for 10 minutes, mixing the reagent with a glass rod after 5 minutes.
- 2 Remove the smears and wash them *well* in water (preferably running water) for 5 minutes. Allow to drain.
- 3 Cover the smears with the toluidine blue-0 stain for 3 minutes. Wash off with water.
- 4 Rapidly decolorize with 95% v/v ethanol. Wash with water. Allow the smears to air dry.
- 5 Add a drop of oil to the smears and cover with a cover glass. Examine with the 10× and 40× objectives.

*Note:* In the method of Gosey *et al*, the smear is dehydrated in 95% v/v ethanol and absolute ethanol, cleared, and mounted.

*Control smear:* Use a smear of *C. albicans* yeast cells as a positive control.

#### Immunofluorescence technique to detect *P. jiroveci*

Several commercially produced immunofluorescence test kits are available to identify *P. jiroveci* in specimens using a monoclonal antibody reagent. Facilities for fluorescence microscopy are required. The test kits are expensive. They are mainly used in reference laboratories.

#### FURTHER INFORMATION

**Leppard B.** *An atlas of African dermatology*. Radcliffe Medical Press, 2002. Available from TALC, PO Box 49, St Albans, AL1 5TX, UK.

**Leppard B.** Skin signs of HIV/AIDS, *Community Dermatology*, 1, pp. 6–9, 2004.

**Wivanitkit V.** Study of the cost-effectiveness of three staining methods for identification of *Pneumocystis carinii* in bronchealveolar lavage fluid. *Tropical Doctor*, January, 35, 2005.

## VIRAL PATHOGENS

### 7.18.53 Dengue virus

#### Pathogenicity

Dengue virus is a flavivirus (see p. 28). Serotypes DEN-1, DEN-2, DEN-3, DEN-4, cause dengue (DEN) and dengue haemorrhagic fever (DHF). The viruses are transmitted by *Aedes* mosquitoes, principally *Aedes aegypti* (day-biting mosquito, found in urban areas, preferring to feed on humans).

Dengue is a major and escalating global health problem. In recent years, inadequate mosquito control, urban population growth, climate changes (El Niño), and greater air-travel have led to the rapid spread of dengue viruses and major epidemics of DEN/DHF, particularly in Southeast Asia, Indian subcontinent, Western Pacific, Central and South America. Dengue viruses can be found in over 100 countries in the tropics and subtropics. With an estimated 2.5 billion people living in areas at risk for epidemic transmission, DEN/DHF is the most important mosquito-borne virus disease affecting humans. An estimated 50 million dengue infections and 500 000 DHF cases occur annually (WHO 2004). As yet, there is no vaccine available to protect against DEN/DHF.

#### Dengue

Dengue is characterized by high fever, headache, pain behind the eye and in muscles and joints, enlarged lymph glands, and a maculopapular rash. Sometimes there is abdominal pain with vomiting, and occasionally haemorrhagic symptoms. The virus multiplies in the reticuloendothelial system and enters the blood circulation. Many infections are mild and self limiting. Early infections are often misdiagnosed as malaria, hepatitis or a flu-like viral illness. High infection rates occur in epidemics (70%–80% of a population can be affected), particularly in endemic countries lacking vector surveillance. Recent developments aimed at reducing dengue transmission include the use of insecticide treated curtains and improved larvicides that can be safely used in drinking water.

#### Dengue haemorrhagic fever (DHF)

This serious life-threatening condition most frequently affects children and others who have been previously infected with one serotype or strain of dengue virus and subsequently become reinfected with a different serotype or strain. The immunological mechanisms leading to DHF are not known exactly. Antibody-mediated enhancement of infection, virus strain, and host genetic factors are involved. In DHF there is vascular damage and disseminated intravascular coagulation (DIC) with spontaneous bleeding. In some patients, DHF progresses to circulatory collapse, referred to as dengue shock syndrome (DSS). The mortality rate in DHF is 10–40%

(mostly children). DHF is characterized by a rising haematocrit (PCV) due to plasma leakage, *together with* a reduced platelet count, hepatomegaly, haemorrhagic symptoms with bleeding into the skin, and a positive tourniquet test.

Dramatic increases in DHF have occurred recently in Asia, the Caribbean, and South America. Epidemic DHF has not yet been reported from Africa but limited outbreaks of DHF have been reported from Djibouti, Mozambique, and other African countries.

#### LABORATORY FEATURES

Laboratory tests which can be helpful in diagnosing DEN/DHF and monitoring the progress of patients being treated for DHF and DSS include:

- *Measurement of haematocrit* (see subunit 8.5): In DHF there is a rise in haematocrit level (often by 20% or more), indicating haemoconcentration due to increased vascular permeability and leakage of plasma.  
*Note:* Bleeding and fluid replacement will affect the haematocrit.
- *Platelet count* (see subunit 8.6): This is greatly reduced (below  $100 \times 10^9/l$ ) in DHF.
- *White cell count and differential* (see subunits 8.6 and 8.7): The white cell count is variable. Leucopenia is common and blood films may show reactive lymphocytes.
- *Coagulation tests*: In DHF, bleeding and clotting times are prolonged and the prothrombin time and partial thromboplastin times are increased. Fibrinogen levels are usually decreased.
- *Clinical chemistry tests*: In DHF, serum aminotransferases and blood urea are raised. Serum sodium and albumin are reduced. Albuminuria is usually present and in some patients also haematuria. Measurement of electrolytes is helpful in monitoring treatment.

#### Serological tests

Serological tests that detect IgM are the most useful in diagnosing primary disease and in distinguishing dengue from other flavivirus infections. An early diagnosis can sometimes be made by testing a single acute serum sample for IgM (65–75% sensitive). Tests that detect IgG are the most useful in diagnosing secondary disease which is associated with more severe disease and a higher mortality. In endemic areas, secondary infections are the most common.

*In primary infection:* IgM antibodies appear about 5 days after the onset of symptoms, continue to rise for about 21 days, and



gradually decrease within 1–2 months of onset. They may be present for up to 6 months. IgG antibodies can be detected about 14 days after the onset of symptoms and persist at a lower level for life. A rising titre suggests active disease.

*In secondary infections:* There is a much weaker and shorter IgM response. The IgG response, however, is rapid (usually 2 days after reinfection) and of a high titre (much stronger than in the primary response). High levels persist for 30–40 days after which levels fall to those found in primary infection.

### **PanBio Dengue Duo IgM and IgG Cassette test**

The *PanBio Dengue Duo IgG and IgM Cassette* is a rapid easy to perform immunochromatographic test that uses recombinant dengue 1–4 antigens to detect dengue-specific IgM and IgG antibodies. The IgM cut-off is set to detect IgM levels characteristic of primary dengue and the IgG cut-off is set to detect high levels of IgG present in secondary infections. Finger prick whole blood, serum or plasma can be used. Test kits can be stored as ambient temperature (up to 30°C).

In the test method, 10 µl of patient's sample is added to the circular well of the cassette using the micropipette provided. After allowing the sample to absorb completely, 2 drops of buffer reagent are added to the square well. Test results are read after exactly 15 minutes. A pink line in the IgM and control areas is indicative of primary dengue. A pink line in the IgG and control areas or in the IgG, IgM and control areas is indicative of secondary dengue. A pink line in the control area only means that no IgM or IgG antibodies have been detected and the reagents have performed satisfactorily. When antibodies are not detected, the test should be repeated after 3–4 days if dengue is still suspected.

In a clinical trial carried out in Malaysia, *Dengue Duo IgG and IgM Cassette* correctly identified 70.8% of primary dengue infections and 86.7% of secondary infections. The test's performance was similar to that of the dengue enzyme-linked immunosorbent assay (ELISA), achieving >90% sensitivity and specificity. The trial showed no significant cross-reactions. Other flavivirus infections (see p. 28), leptospirosis, cytomegalovirus, Epstein-Barr virus (EBV) and rheumatoid factor may occasionally show cross-reactions (more frequently in the IgM test line).

**Availability:** The *Dengue Duo IgM and IgG Cassette* test is available from PanBio (see Appendix 11), catalogue No. R-DEN03D. Each test kit contains 25 individually packaged test cassettes each with a 10 ml pipette, and 3 ml of buffer. The test kit can be stored at 2–30°C.

*Note:* A rapid (15 minute) immunochromatographic *IgM and IgG Dengue Strip* test is also available from PanBio but this test can only be used with serum and test kits require storage at 2–8°C.

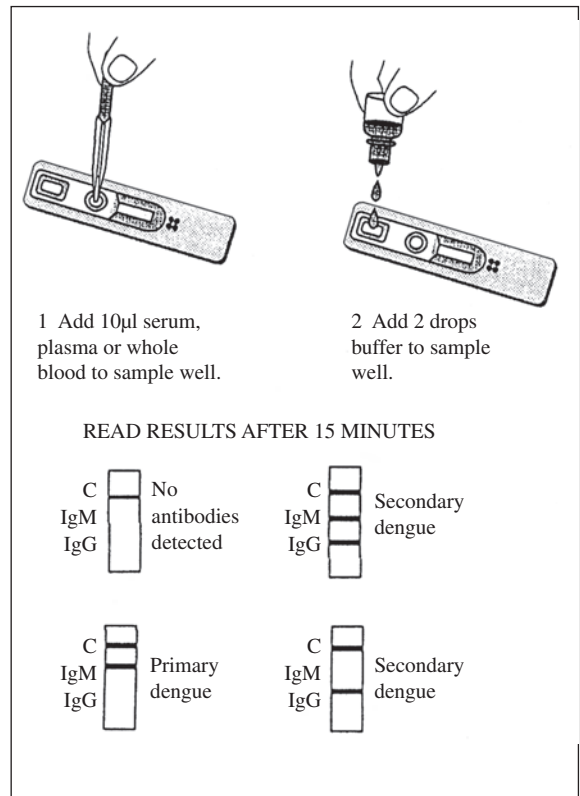

Fig. 7.54 PanBio *Dengue Duo IgM and IgG* test. Courtesy of PanBio.

### **Microtitration plate techniques to detect dengue antibodies**

A range of microtitration plate ELISA to measure IgM and IgG are available from PanBio Ltd. The *Dengue Duo ELISA* which measures separately IgM and IgG (supplied as two microtitration plate sets) is the most useful of the range in investigating dengue in endemic areas where secondary infection is common. The *Dengue Duo ELISA* incorporates antigens stabilized in the well of a microtitration plate. The microtitration plate format enables large numbers of specimens to be economically tested at one time in a reference laboratory. Equipment required to perform the dengue EIAs is similar to that required for other ELISAs, including a microtitration plate reader (reading at 450 nm). Results are read by comparison to the IgM and IgG reference sera provided (cutoff calibrators). Cross-reactions occur with other flavivirus infections. Further information on the range of dengue assays, availability and prices can be obtained from PanBio Ltd (see Appendix 11).

### **FURTHER INFORMATION**

**Stephenson JR.** The problem with dengue. *Transactions Royal Society Tropical Medicine & Hygiene*, 99, pp. 643–646, 2005.

CD-ROM *Topics in international health – Dengue*. Wellcome Trust, 2005. Available from TALC, PO Box 49, St Albans, AL1 5TX, UK. Website www.talcuk.org.

## 7.18.54 Hepatitis viruses

The following viruses are recognized as causing viral hepatitis:

Hepatitis A virus (HAV)  
 Hepatitis B virus (HBV)  
 Hepatitis C virus (HCV)  
 Hepatitis D virus (HDV)  
 Hepatitis E virus (HEV)  
 Hepatitis G virus (HGV)

**Note:** A group of viruses originally referred to as ‘hepatitis F’ are now known to be variants of hepatitis C.

**Note:** Hepatitis can also occur with other viral and bacterial infections, including yellow fever, Ebola fever, Marburg disease, Rift Valley fever, infection with herpesviruses HHV-4 (cytomegalovirus) and HHV-5 (Epstein-Barr virus), and leptospirosis. It can also be caused by the ingestion of toxins, including alcohol.

### HAV

**Virus:** RNA, single stranded, unenveloped picornavirus. HAV is a highly stable virus.

**Transmission:** HAV is excreted in faeces. Infection is via faecally contaminated hands, food or water. HAV is endemic in developing countries with infection commonly occurring in childhood and conferring life-long immunity. Incubation period is 2–6 weeks. Large numbers of viruses are excreted in faeces for 4 weeks preceding the onset of symptoms.

**Pathogenicity:** Infection in children is usually asymptomatic. Adults usually develop hepatitis with jaundice. The disease is self-limiting. There is no carrier state and HAV does not cause chronic liver disease. A vaccine is available to protect against hepatitis A (particular value to those travelling to endemic areas).

### HBV

**Virus:** DNA, double stranded (with single stranded regions), enveloped hepadnavirus. The virus, often referred to as a Dane particle, carries hepatitis B core antigen (HBcAg), surface antigen (HBsAg), secreted protein antigen (HBeAg), and viral DNA. During infection, Dane particles are released into the bloodstream together with small spherical and rod-like particles of envelope origin. The spherical and rod-like particles carry HBsAg and are non-infective. Hepatitis B e antigen (HBeAg) is part of the core protein of Dane particles and its presence in the blood is associated with infectivity. It is secreted from infected liver cells during the acute stage of the disease and in some carriers, when there is active virus replication.

**Transmission:** HBV is spread by blood, body fluids, and close personal contact. In developing countries the main routes of transmission are:

- neonatal with an HBV carrier mother infecting her infant, usually during birth or soon after birth following close contact,
- transfer of HBV via open wounds, bites, cuts and grazes,
- sexual transmission,
- transfusion of infected blood or blood products when donor blood is not screened,
- needlestick injury and other sharps injuries,
- contamination of eye,
- reuse of HBV contaminated needles, syringes, lancets, razors, and instruments including those used in tattooing, ear piercing, acupuncture, and tribal ceremonies,
- possibly sharing cups and spoons.

High HBV carrier rates are found in sub-Saharan Africa, Kalahari desert areas, Southeast Asia, China, Pacific islands and the Amazon basin. Most people become infected at birth or during childhood, or by sexual contact, and up to 20% become chronic carriers, particularly those infected between 1–5 years. Worldwide, there are estimated to be 450 million chronic carriers of HBV. Hepatitis B has an incubation period of 2–6 months.

**Pathogenicity:** HBV causes the most serious form of viral hepatitis. Persistence of the virus in chronic carriers can lead years later to the development of liver cirrhosis and liver cancer. The virus causes 60–80% of all primary liver cancer and is a major cause of cancer death in East and Southeast Asia, the Pacific Basin and sub-Saharan Africa. Vaccination is an effective way of preventing HBV transmission and children becoming carriers providing this is done early in life. An increasing number of countries are introducing hepatitis B vaccine with their national immunization programmes.

### HCV

**Virus:** HCV is an RNA, single stranded, enveloped flavivirus. HCV shows considerable genomic variation. Six genotypes are recognized. The virus infects liver cells and is also thought to infect mononuclear cells in peripheral blood.

**Transmission:** HCV is spread by blood to blood contact e.g. unscreened blood transfusion, contaminated needles. HCV is not as easily transmitted as HBV. Only small numbers of the virus are excreted and circulate in the blood. Information on the epidemiology of HCV in developing countries is incomplete. In some tropical areas, HCV may be spread by the re-use of contaminated instruments in tribal ceremonies. The prevalence of HCV seropositivity in various populations of Africa ranges from 0.2%–40%. In Egypt and Cameroon where genotype 4 is present, seropositivity rates of 30–40% have been reported. High prevalence rates are also found in the Middle East. Infection rates of 2.5–10% occur in parts of South America and Asia. The incubation period is 6–8 weeks.

**Pathogenicity:** Infection with HCV is often asymptomatic. Only about 10% of individuals become jaundiced. WHO, however, estimates that worldwide there are about 170 million chronic carriers of HCV at risk of developing liver cirrhosis and liver cancer. Chronic hepatitis C following acute infection develops in 70–80% of individuals. Co-infection with HBV and HIV can accelerate HCV disease and its com-

plications. In those with pre-existing liver disease, infection with HCV increases the severity of disease. Auto-antibodies and cryoglobulins are often found in patients. As yet there is no vaccine to protect against hepatitis C. Infected individuals can be treated with antiviral drugs.

#### HDV (delta agent)

*Virus:* This is an incomplete RNA single stranded unenveloped virus. HDV depends on HBV envelope proteins to replicate and is therefore found only in those infected with HBV. HDV is coated with HBsAg.

*Transmission:* HDV is transmitted in the same ways as HBV. High infection rates occur in South America and the Mediterranean regions. Infection rates in Africa are unknown.

*Pathogenicity:* Co-infection with HDV can cause severe HBV hepatitis, particularly in HBV carriers. It also increases the risk of chronic HBV infection. Vaccination with HBV vaccine is effective in protecting against HDV.

#### HEV

*Virus:* RNA single stranded unenveloped virus, similar in structure to a calicivirus.

*Transmission:* HEV, like HAV is spread faeco-orally, often via faecally contaminated water. It is endemic in most developing countries where it causes sporadic infections and major hepatitis epidemics, often following storms and flooding. Large outbreaks have been reported from Mexico, North Africa, India and northern Kenya in refugee camps. It occurs mainly in young adults. The incubation period is 3–6 weeks. There is no carrier state.

*Pathogenicity:* Infection with HEV in the late stages of pregnancy can be severe and may be fatal (10–30% mortality rate).

#### HGV

*Virus:* RNA, single stranded enveloped flavivirus, similar to HCV. Several variants exist. HGV exists worldwide.

*Transmission:* HGV is transmitted by blood and body fluids and may be found in all body tissues.

*Pathogenicity:* HGV is known to cause flu-like symptoms and possibly more severe disease. Long term effects are as yet unknown.

Symptoms of viral hepatitis include nausea, loss of appetite, gastrointestinal upset, malaise and an enlarged painful liver.

With severe hepatitis, symptoms are more acute, with jaundice, fever, headache, pain in the muscles and joints and often a skin rash. The patient will notice that the urine is dark and the faeces pale.

Recovery from viral hepatitis is usually slow. Chronic hepatitis and carrier state may follow infection with HBV, HDV, HGV and HCV.

*Note:* Chronic hepatitis B and C can lead to cirrhosis of the liver and liver cancer.

**Chart 7.8 Features of hepatitis viruses**

<i>Virus</i>	<i>Transmission</i>	<i>Carrier state</i>	<i>Vaccine</i>
<b>HAV</b>	Faecal-oral	No	Yes
<b>HBV</b>	Blood, body fluids, close contact	Yes	Yes
<b>HCV</b>	Blood	Yes	No
<b>HDV</b>	Blood	Yes	Yes
<b>HEV</b>	Faecal-oral	No	No
<b>HGV</b>	Blood, body fluids	Yes	No

*Notes:* HBV is a DNA virus. HAV HCV HDV HEV and HGV are RNA viruses. HDV is an incomplete virus, found only in those infected with HBV. HCV shows considerable genomic variation.

## LABORATORY FEATURES

*Caution:* Hepatitis viruses are infectious, particularly HBV which is 50 to 100 times more infectious than HIV. It is therefore important for laboratory staff to handle specimens with care, minimize procedures which create aerosols, and take special care when collecting blood to avoid needle-stick injury. The safe handling, decontamination, and disposal of specimens are described in Chapter 3 in Part 1 of the book.

### *Clinical chemistry tests*

Investigations which are helpful in differentiating hepatocellular jaundice due to viral hepatitis from haemolytic jaundice and obstructive jaundice, are described in subunit 6.6 in Part 1 of the book.

Serum aminotransferase enzyme activities (ALT and AST) are increased. In the pre-icteric stage, urobilinogen can be found in urine, and when there is jaundice, serum bilirubin levels are increased and bilirubin is present in the urine. Many viral hepatitis infections, however, are anicteric (without jaundice) but aminotransferase activity is increased. Measurement of serum albumin can provide information on the severity of the hepatitis.

### **Immunological investigations**

A range of antigen and antibody tests are available to assist in the diagnosis of viral hepatitis and screening donor blood for HBV and HCV.

### **Hepatitis B**

During HBV infection, many virus particles are released from infected liver cells, resulting in large amounts of viral antigen entering the blood.

Hepatitis B surface antigen (HBsAg) is present in the blood about 2 weeks before the onset of symptoms, and persists throughout the clinical course of the disease. At the start of recovery it declines and is no longer detectable after 4–5 months. Persistence of HBsAg beyond 6 months indicates chronic infection/carrier state.

### **HBsAg tests**

Testing for HBsAg is used to screen donor blood for HBV infectivity, and depending on resources, to test pregnant women for HBV carrier status. HBsAg tests include ELISA (microtitration plate), rapid immunochromatographic (IC) tests and latex agglutination tests. Most of the IC tests are in cassette form. When screening blood, a sensitive test is required to ensure HBV infected blood is reliably detected, and also a test with adequate specificity to avoid false positive reactions resulting in blood being wasted unnecessarily. Most of the currently available HBsAg tests have high sensitivity and specificity. The rapid IC tests are particularly easy to perform and can be read visually.

*Note:* Details on the sensitivity, specificity, and other performance characteristics and comparative costs of commercially available rapid and ELISA HBsAg tests with details of manufacturers can be obtained from the WHO Diagnostics and Laboratory Technology Unit:\*

\*WHO Essential Health Technologies Unit, WHO, 1211 Geneva, 27-Switzerland.

- Report 1 (2001) WHO/BCT/BTS/01.4 provides evaluations with illustrations of 10 rapid simple to perform HBsAg assays.
- Report 2 (2004), ISBN 94 415 92206 provides evaluations with illustrations of 5 ELISA assays.

Both these Reports can be downloaded from the WHO website [www.who.int](http://www.who.int) (use the Search facility, entering 'rapid hepatitis tests').

*Hepatitis B e antigen (HBeAg)* Appears soon after HBsAg and persists for a short time, disappearing when recovery begins. Its presence is associated with increased infectivity. Persistence of e-antigen indicates chronic liver disease. Tests to detect HBeAg are usually performed only in specialist laboratories.

### **Antibody markers of hepatitis B**

- IgM antibody to hepatitis B core antigen (anti-HBc IgM) appears only in acute infection and is a useful marker of recent infection. The presence of IgG antibody to HBcAg (anti-HBc IgG) in the absence of IgM, indicates past infection (used in seroepidemiological studies).
- Antibody to HBsAg (anti-HBs) is the last serological marker to form, appearing in the convalescence stage. It indicates recent infection or past immunization.

- Antibody to HBeAg (anti-HBe) may be found in the convalescence stage and often in chronic hepatitis and the carrier state.

*Note:* Testing for HBV antibodies is usually performed only in specialist laboratories.

### **Hepatitis C**

During HCV infection, the amount of viral protein (antigen) released into the blood is usually small and therefore not easily detected. Sensitive nucleic acid tests have been developed to detect viral RNA. Such tests however, are expensive and designed for use in reference laboratories.

### **Antibody testing for HCV**

The diagnosis of hepatitis C infection is usually made serologically by detecting anti-HCV IgG in serum. Most patients infected with HCV become carriers. Antibody is detectable 6–8 weeks after infection. Detecting anti-HCV antibody is also used to screen donor blood.

ELISA and rapid anti-HCV antibody tests to diagnose hepatitis C and screen blood for HCV are commercially available. Details on the sensitivity, specificity and other performance characteristics and comparative costs of some commercially available anti-HCV antibody tests can be obtained from WHO Diagnostics and Laboratory, Essential Health Technology Unit:

- Report 1 (2001) WHO/BCT/BTS/01.2 provides evaluations with illustrations of 5 simple/rapid hepatitis C antibody assays.
- Report 2 (2001) WHO/BCT/BTS/01.5 provides evaluations of 2 simple/rapid and 3 ELISA hepatitis C antibody assays with illustrations.

Both these Reports can be downloaded from the WHO website [www.who.int](http://www.who.int) (use Search facility to locate the Reports).

### **HAV, HDV, HEV**

Hepatitis A can be diagnosed serologically by detecting HAV-specific IgM antibody which appears in the serum at the onset of jaundice and persists for about 10 weeks. Antigen and antibody tests are available to diagnose hepatitis D and hepatitis E, but the assays are expensive and usually performed only in specialist laboratories.

### **FURTHER INFORMATION**

**Lavanchy D.** Hepatitis B epidemiology, disease burden, treatment and current and emerging prevention and control measures. *Journal Viral Hepatitis*, Vol. 11, 2004.

**Mishra B. et al.** A hospital based study of hepatitis E by serology. *Indian Journal Medical Microbiology*, 21, 2, 2003.

## WEBSITE

WHO website [www.who.int](http://www.who.int) (use Search facility to locate Hepatitis).

## 7.18.55 Human immunodeficiency virus (HIV)

Human immunodeficiency virus (HIV) causes progressive impairment of the body's cellular immune system, leading to increased susceptibility to infections and tumours, and the fatal condition AIDS (acquired immunodeficiency syndrome). There are two main types of the virus, HIV-1 which causes most HIV infections worldwide and HIV-2 which is found mainly in West Africa. HIV-2 is less easily transmitted than HIV-1 and the period between initial infection and illness is longer than with HIV-1.

### Structure of HIV

HIV is an enveloped RNA virus belonging to the lentivirus subgroup of retroviruses, which cause slowly progressing diseases, often with long incubation periods. By possessing the enzyme reverse transcriptase, retroviruses are able to reverse-transcribe RNA to DNA (normally RNA is transcribed from DNA). The DNA genome produced (provirus) becomes integrated in the DNA of the infected cell, ensuring permanent infection and replication of the virus.

Structurally HIV consists of:

- An inner core containing two copies of single stranded RNA, viral enzymes and capsid protein p24 (group-specific core antigen which does not vary).
- Double layered lipid envelope, derived from the membrane of the host cell. The envelope contains virus specific glycoproteins gp120 (protrudes from the surface) and gp41 (embedded in the envelope). These enable the virus to attach to and infect host cells. The gene that encodes gp120 mutates rapidly, producing many antigenic variants.

### Groups and subtypes of HIV

Each HIV type is subdivided into different groups, referred to as M, O and N. More than 90% of HIV infections belong to HIV-1 group M. Groups N and O are mainly limited to countries in West Central Africa. HIV-1 group M strains are further subdivided into at least 9 subtypes, designated A–D, F–H, J and K. Genetic recombination between different subtypes has resulted in circulatory recombinant forms (CRFs). Additional subtypes and CRFs are likely to emerge. In Africa most subtypes can be found. Subtypes A and D predominate in sub-Saharan Africa. Subtype C is found in southern and eastern Africa (including Zambia, Zimbabwe, Malawi), Nepal and India. Subtype E is found in Southeast Asia. Subtype F is found in South America and Romania. Some subtype B strains are linked to transmission by intravenous drug use and are the main subtypes found in the Caribbean, Americas, Japan, Australia, Europe and elsewhere. Subtype H has been found in central Africa, J in

central America and K in Cameroon and central Africa. Differences in the ease of transmission, virulence and disease progression may occur between strains.

### Transmission of HIV

HIV is present in semen, vaginal/cervical secretions and blood, and these are the main vehicles by which the virus is transmitted. The virus may also be present in saliva, tears, urine, breast milk, cerebrospinal fluid and infected discharges.

The stage of illness of an infected person influences the probability of HIV transmission. The risk of transmitting the virus is highest in the early (seroconversion) and late stages of disease when viral numbers are at their highest.

In tropical and developing countries, HIV is mainly transmitted by:

- Heterosexual sexual intercourse (85–95% transmission). HIV tends to be more easily transmitted from males to females. Male to female transmission risk is highest in young girls aged 16 years or less. Frequent changes in sexual partners increases the risk of transmission. Sex workers and their clients are particularly at risk.
- Sexual practice involving anal intercourse.
- Mother to child transmission during pregnancy, labour and delivery (commonest mode of transmission which carries 15–30% risk) or breast-feeding (10–15% risk of transmission).
- Transfusion of infected blood or blood products where HIV screening of donor blood is not performed.
- Use of contaminated syringes and needles by intravenous drug users. HIV infection can also be spread by the reuse of inadequately sterilized needles in clinics and hospitals and instruments used in tribal ceremonies.

*Note:* There is no epidemiological evidence that HIV is transmitted through air, water or food, sharing eating utensils, coughing or sneezing, toilets, insect bites, shaking hands or other casual contact.

### Sexually transmitted infections and HIV

The risk of becoming infected with HIV or passing on the virus is estimated to be 6 to 10 times greater in persons with a sexually transmitted disease which causes discharge and genital ulceration such as syphilis, genital herpes (HSV-2), or chancroid. A significant risk is also associated with gonorrhoea, chlamydial infection and trichomoniasis.

**Preventing HIV infection:** For further information on risk factors associated with the transmission of HIV and strategies to prevent infection and control the spread of HIV, readers are referred to the publications and websites listed under *Further information* at the end of this subunit.

### HIV/AIDS in tropical countries

In tropical and low income countries, HIV disease/AIDS is a major public health problem, socio-economic burden, and a serious threat to development. At the end of 2004, the Joint United Nations Programme on HIV/AIDS (UNAIDS)<sup>1</sup> estimated that globally there were 39.4 million people living with HIV/AIDS. As shown in Fig 7.33, about 64% of the total number of infected people live in sub-Saharan Africa.

An estimated 3.1 million deaths occurred during 2004. The highest loss of life and severe disease were among young adults, aged 15–24 years. In some parts of South Africa, 20–26% of people aged 15–49 are living with HIV/AIDS. About one third of infants born of infected mothers become HIV infected and die before they are 5 years old (25% within 12 months). In sub-Saharan Africa, the number of children orphaned due to AIDS rose from 11.5 million in 2001 to 15 million in 2003.

In Asia it is estimated that about 8.2 million people are HIV infected. HIV is spreading rapidly in India and China and serious epidemics have been reported in Cambodia, Myanmar and Thailand. Estimated figures for other parts of the developing world are shown in Fig 7.33. In Latin America and

the Caribbean, the pattern of HIV spread is similar to that found in industrial countries with infections occurring predominantly in homosexual men and intravenous drug users with heterosexual transmission increasing.

**Impact of AIDS pandemic:** Information on the humanitarian, social and economic impact of the AIDS pandemic can be found on the UNAIDS website [www.unaids.org](http://www.unaids.org).

### HIV disease

HIV infects cells bearing the CD4 antigen receptor, the most important being T-helper lymphocytes (CD4+ T cells). These cells regulate cellular and humoral immunity by interacting with other T lymphocytes, B lymphocytes, macrophages, and natural killer cells. When CD4+ T cells are depleted, immune defences are weakened. HIV also infects other CD4+ cells including macrophages, monocytes and cells in the skin, intestinal tract, brain and bone marrow.

The CD4 antigen receptor binds to the HIV envelope glycoprotein, gp120. Fusion of the virus with the cell membrane and its entry into the host cell require the presence of co-receptors. The most important of these are the chemokine co-receptors CCR5 and CXCR4. Different strains of HIV are attracted preferentially to different co-receptors.

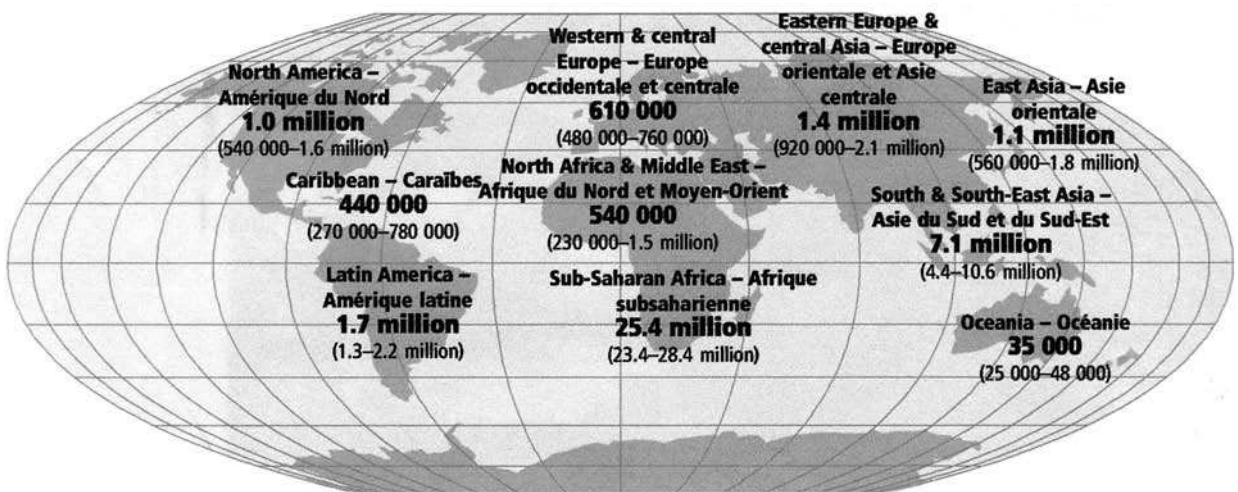

Fig 7.33 Number of adults and children estimated to be living with HIV/AIDS at the end of 2004. Total: 35.9–44.3 million. Source: UNAIDS/WHO, December 2004

These co-receptors not only influence the CD4+ cells infected by HIV strains but they are also thought to be involved with other factors in the progression of HIV disease. Recent work suggests that the intestinal tract and other mucosal tissues are the major sites of HIV infection, persistent viral replication and the loss of CD4+ T cells in HIV infected individuals with memory CD4+ T cells being rapidly and selectively destroyed in primary infection.<sup>2</sup>

Four stages can be recognized in the progression of HIV disease:

- Primary infection and seroconversion
- Clinically latent stage
- Early HIV disease
- Late HIV disease and AIDS

#### Primary infection and seroconversion

Shortly after infection with HIV, initial replication gives rise to increasing concentrations of virus in the blood and the virus becomes seeded widely throughout the tissues of the body. A decrease in the number of CD4+ T cells is usually associated with the primary infection. Antibodies to the virus core and envelope antigens are produced (IgM first, rapidly followed by IgG). During this time approximately 50% of people develop an acute glandular fever-like illness with some or all of the following symptoms: sore throat, oral ulcers, enlarged lymph glands, fever, malaise, skin rash, and occasionally arthralgia and neurological symptoms. This is called a seroconversion illness because it occurs at a time when the infected person is first making antibodies against HIV. The seroconversion illness usually resolves in 1–3 weeks. Following seroconversion and the presence of detectable antibodies in the serum, a person is described as being seropositive.

Some people when first infected with HIV experience only mild symptoms or are asymptomatic and not aware that they have been infected and are infectious to others. Even those who have experienced a seroconversion illness may not be aware that it was due to HIV. The time between infection and when antibodies are detectable is called the 'window period'. Although this is typically 3–6 weeks, some individuals become seropositive only after several months.

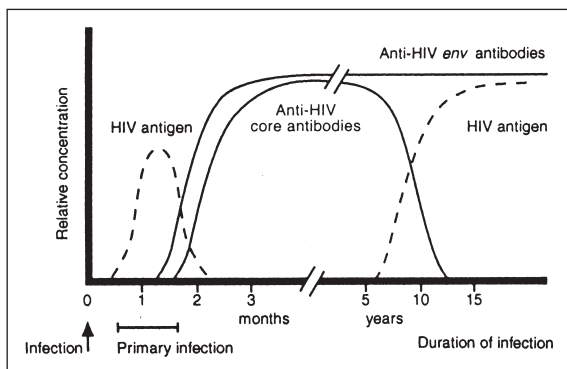

Fig 7.34 Antibody and antigen production in HIV infection. Reproduced from *Laboratory diagnosis of sexually transmitted diseases*, WHO, 1999 with the permission of the World Health Organization.

#### Clinically latent asymptomatic stage

Most adults remain well for several years after acquiring HIV and seroconverting, but during this time they remain infectious and can transmit the virus to others. Although the infected person is asymptomatic, the virus is not dormant. During this stage, HIV is actively replicating in lymphoid tissues, gradually destroying the immune system.

Infants infected with HIV develop symptoms soon after infection, often within a few months (see later text *Paediatric HIV disease*).

#### Early HIV disease

Whereas in non-developing countries, most illness associated with HIV disease is due to opportunistic pathogens and cancers that occur when there is significant immunosuppression, in tropical and developing countries, illness often occurs at an *early* stage (when CD4+ T cells are only slightly depleted) due to endemic pathogens, particularly:

- *Streptococcus pneumoniae*, causing pneumonia and sinusitis. *S. pneumoniae* is usually the earliest pathogen causing disease in those infected with HIV and recurring, severe infections are common.
- *Mycobacterium tuberculosis*, with HIV co-infection increasing by thirty times the risk of developing active tuberculosis, extra-pulmonary tuberculosis (lymphadenopathy, pericardial disease, pleural effusion, meningitis) and miliary tuberculosis. Active tuberculosis accelerates the progress of HIV disease. HIV-related tuberculosis is the cause of one third or more of deaths in those with HIV/AIDS.

These treatable infections are frequently the cause of considerable suffering and early death in HIV infected adults.

Other symptoms of early HIV disease in developing countries include fever and night sweats, chronic diarrhoea, weight loss, lymphadenopathy (enlarged lymph glands), cough, an itchy maculopapular generalized skin rash, *Candida* infection of the mouth and vagina, and hairy leukoplakia (hairy-like projections forming ridges along the side of the tongue, possibly due to Epstein-Barr virus). Infection with herpes zoster virus is another frequent early sign of HIV infection. In tropical African countries, about 95% of individuals with shingles are HIV seropositive. Mucocutaneous and disseminated herpes simplex infections are also common. With falciparum malaria, HIV immunosuppression increases parasitaemia and malaria is more severe in pregnancy.

#### Late HIV disease and AIDS

In advanced untreated HIV disease with severe immunosuppression, there is a decrease in the number of CD4+ T cells to below 400 cells/ $\mu$ l, falling in AIDS to below 200 cells/ $\mu$ l (the normal CD4+ cell count in HIV negative adults is about 1 000 cells/ $\mu$ l). Patients are anaemic, leucopenic, and often thrombocytopenic.

In tropical countries, in addition to acute respiratory infections, tuberculosis, and skin disease, the main conditions that occur in late HIV disease are:

- Non-typhoidal salmonellae (e.g. *S. Typhimurium*, *S. Enteritidis*), causing bacteraemia.
- Diarrhoea-wasting syndrome ('slim' disease) in which there is chronic watery diarrhoea, weight loss with wasting, and severe weakness. Causes include infection of the gastrointestinal tract with opportunistic parasitic pathogens such as *Cryptosporidium* species, *Cyclospora*, *Isospora belli*, and microsporidia.

- Cryptococcal meningitis in areas where there is a high prevalence of *Cryptococcus neoformans*.
- *Cerebral toxoplasmosis* caused by the protozoan parasite *Toxoplasma gondii* and other HIV related neurological disorders.
- Visceral, cutaneous, and diffuse leishmaniasis in areas where HIV and *Leishmania* species overlap. Recrudescence infections are common.
- Systemic infection with the fungus *Penicillium marneffeii* (common opportunistic pathogen in Southeast Asia).

*Note:* Less commonly occurring opportunistic pathogens include: *Pneumocystis jirovecii* (common in young children), cytomegalovirus, *Mycobacterium avium-intracellulare*, and *Histoplasma capsulatum*.

#### *Malignant conditions*

Important malignant conditions associated with HIV include Kaposi sarcoma and non-Hodgkin's lymphoma (visceral and cerebral lymphomas). Kaposi sarcoma affects the endothelial cells of blood vessels. The form seen in association with HIV is an aggressive generalized disease appearing as dark coloured plaques and nodules on the skin and involving the lymph nodes, mouth, gut and lungs. There is increasing evidence that the human herpesvirus, HHV-8, is the cause of Kaposi sarcoma.

**WHO clinical staging for HIV infection and HIV related disease:** Details can be found in the 2nd edition (2004) *TB/HIV – A Clinical Manual* (see Further information at the end of this subunit).

#### **Paediatric HIV disease**

Most infants and children infected with HIV have acquired infection from their HIV positive mother during pregnancy or more often during labour and delivery, or after birth from infected breast milk. Between 15–30% of infants born to HIV infected mothers become HIV infected. The risk of transmission is higher in mothers who have other sexually transmitted diseases, are undernourished, or have HIV infection with high viral load. Infection in pregnancy can cause stillbirth, premature birth and low birth weight.

The other main way children become infected in tropical and developing countries is by being transfused HIV infected blood (usually to treat life-threatening severe anaemia caused by malaria). Most HIV infected children develop symptoms soon after infection. They fail to thrive, often have fever, anaemia and skin rash, develop chronic diarrhoea, and get recurrent chest infections with persistent cough. Bacterial and viral pneumonias are common and also *Pneumocystis pneumonia*. Oral candidiasis, tuberculosis, *Salmonella* septicaemia, lymphadenopathy, bacterial and cryptococcal meningitis, skin and eye infections also occur. Measles occurs more frequently and is usually more severe in HIV infected children. Death frequently occurs within 2–5 years and sometimes earlier from pneumonia, enteritis, or meningitis. HIV infection transmitted by blood transfusion progresses rapidly to late HIV disease and AIDS.

#### *Serological diagnosis of paediatric HIV disease*

Diagnosis of paediatric HIV disease is difficult. Infants born of HIV positive mothers have maternal anti-HIV antibody in their blood for up to 18 months, and therefore a serological diagnosis based on a positive antibody test is not possible until

the infant develops its own antibodies and antibody from the mother can no longer be detected. After 18 months the presence of anti-HIV antibody in an infant indicates the presence of HIV infection. HIV antigen tests (p24) may be used to make an early diagnosis, but are not wholly sensitive and the tests are expensive. Most infants are therefore diagnosed as having HIV infection from clinical symptoms.

### **LABORATORY FEATURES**

The laboratory diagnosis of HIV infection is by detecting antibody to HIV (anti-HIV 1, anti-HIV 2) in a person's serum (see later text). Anti-HIV is usually present within 3–6 weeks following infection. Serological tests are also used to screen blood for HIV. Counselling should accompany HIV testing (see later text).

In the clinical care of patients, microbiological tests are required to investigate HIV-related infections. Useful information can also be obtained from haematological tests (see later text).

#### **Microbiological tests**

Microbiological tests are mainly used to investigate:

- Pneumonia
- Tuberculosis
- Meningitis (bacterial and cryptococcal)
- Bacteraemia and septicaemia
- Abscesses and unhealing wounds
- Fungal infections
- Persistent diarrhoea
- *Leishmania* infections
- Cerebral toxoplasmosis
- Syphilis and other sexually transmitted diseases

Investigations include:

*Pneumonia:* Microscopical examination of sputum for pus cells and bacteria (particularly Gram positive diplococci suggestive of pneumococci) and culture of sputum for *S. pneumoniae* are described in subunit 7.18.4. Examination of specimens to detect *Pneumocystis jirovecii* is described in subunit 7.18.52.

*Tuberculosis:* Microscopical examination of Ziehl-Neelsen stained sputum smears for acid fast bacilli (AFB), is described in subunit 7.3.5. In patients with negative sputum smears it may be possible to find AFB in smears from aspirates of cervical or axillary lymph nodes, or in smears from the cut surface of an excised lymph node. Pericarditis and pleural effusion caused by *M. tuberculosis* are usually diagnosed clinically. AFB are rarely found in tuberculosis exudative serous effusions.

*Meningitis:* HIV related meningitis can be of viral,



bacterial, or fungal origin. The biochemical and microbiological examination of c.s.f. for pathogens including cryptococci are described in subunit 7.13.

*Bacteraemia and septicaemia:* Common causes in HIV infection are *S. Typhimurium* and *S. Enteritidis*, other enterobacteria, *S. pneumoniae*, *S. aureus*, and *M. tuberculosis*.

*Wound infections and abscesses:* Microscopical examination and culture of pus and discharges are described in subunit 7.8. *S. aureus*, and *S. pyogenes* are common pathogens in HIV infections.

*Fungal infections:* Identification of *Aspergillus* species is described in subunit 7.18.49, *P. marneffeii* in 7.18.50, *H. capsulatum* in 7.18.43, *Pneumocystis* in 7.18.52 and *C. albicans* in 7.18.47.

*Persistent diarrhoea:* The examination of faecal specimens for *Isospora belli*, *Cyclospora* and *Cryptosporidium* and microsporidia can be found in subunit 5.4 in Part 1 of the book.

*Sexually transmitted infections (STIs):* Increase the risk of HIV transmission, particularly infection with *T. pallidum* (syphilis), *H. ducreyi* (chancroid), *N. gonorrhoeae* (gonorrhoea). Examination of urogenital specimens is described in subunit 7.10. The serological diagnosis of syphilis is described in subunit 7.18.32.

*Cerebral toxoplasmosis:* The laboratory diagnosis of this condition is discussed in subunit 5.14 in Part 1 of the book.

*Leishmania infections:* HIV associated *Leishmania* infections and their diagnosis are covered in subunit 5.10 in Part 1 of the book.

### Haematological tests

Tests which can be performed in district laboratories and provide useful information in HIV disease include:

- Measurement of haemoglobin or PCV to assess anaemia
- Total and differential white cell count
- Platelet count

*Acute seroconversion illness:* The haematological findings resemble those seen in infectious mononucleosis (glandular fever) with a lymphocytosis and presence of reactive lymphocytes in the blood film. The laboratory, however, is not often required to investigate this stage.

*Haematological findings in early HIV disease:* The white cell count and differential reflect the infections that commonly occur at this early stage of immunosuppression (see previous text). Polyclonal activation of B cells is common, resulting in high immunoglobulin levels. Thrombocytopenia frequently occurs, due in the early stages to autoimmune destruction and in late stage disease, to bone marrow failure.

*Haematological findings in late HIV disease:* As CD4+ T cells are destroyed and immune responses fail, the conditions associated with immunosuppression and AIDS develop (see previous text). Patients become progressively anaemic, thrombocytopenic, leucopenic with lymphopenia and neutropenia. Anaemia is usually normocytic and normochronic but can also be macrocytic.

Commenting on the general haematological features that can be seen in peripheral blood films in patients with AIDS, Bain mentions that neutrophils may show dysplastic features or toxic changes due to intercurrent infection, e.g. toxic granulation, Döhle bodies, cytoplasmic vacuolation, and left shift. Neutrophils sometimes show detached nuclear fragments and giant metamyelocytes can sometimes be seen. Reactive (atypical) lymphocytes may be present, some having a lobulated nucleus and sometimes showing vacuolation. When there is immune destruction of platelets, larger than normal platelets may be seen. For the changes that occur in the bone marrow, readers are referred to the Bain's paper (see Further information).

### Counting CD4 T lymphocytes

The normal CD4 T cell count for an adult is just over 1 000 cells/ $\mu$ l. In HIV disease, CD4 T cells are destroyed, resulting in progressive immunosuppression. In developing countries, CD4 T cell counts are mostly performed in regional laboratories or specialist virology laboratories to obtain information on immune responses and staging of HIV disease, risk of mother to child transmission of HIV, and use of and response to antiretroviral treatment.

#### Technologies used to count CD4+ T cells

CD4+ T lymphocytes cannot be identified in a routine stained blood film. Special techniques, not usually available in district laboratories, are required to count CD4+ T cells. Techniques include automated flow cytometry methods such as *Guava EasyCD4 System*, Becton Dickinson *FACSCount*, *Partec CyFlow*, *PointCare*, and manual methods such as the Beckman Coulter *Cyto-Spheres* and Dynal *Dynabeads*. These technologies have been reviewed by WHO Essential Health Technologies Unit in a 2005 document *CD4 T-cell enumeration technologies – Technical Information* (can be downloaded from website [www.int/eht](http://www.int/eht)). The equipment to perform these technologies is expensive and for some technologies running

costs are also high. Special training is required to operate and maintain flow cytometers.

*Note:* Other simpler more affordable CD4+ T cell assessment technologies are under development e.g. simple *CD4+ T lymphocyte Test* (semi-quantitative test to assess CD4+ T cells) being developed by PATH organization (see Appendix 11).

### Serological tests

Most tests used to diagnose HIV infection are antibody tests. HIV antibodies are detectable in the blood of nearly all infected persons within 3 months of exposure although very occasionally it may take longer.

**Saliva antibody tests:** While antibody to HIV can be found in saliva (and urine), its concentration is usually lower than that found in serum or plasma. While sufficiently sensitive for surveillance testing, saliva tests are not recommended for diagnostic testing. For diagnosis, a serum, plasma or whole blood HIV antibody test should be used.

*A positive HIV antibody test* indicates that a person is infected with HIV and can potentially transmit the virus to others. It is not diagnostic of AIDS.

*A negative HIV antibody test* indicates that a person is not infected with HIV or the test has been performed too soon after exposure, before HIV antibody has reached detectable levels, i.e. 'window period'. When infection is suspected, the test should be repeated a few weeks later. A false negative result can occur if the test used is not able to detect the antibody response to infection with a highly diverse HIV strain, but this is rare if a test of proven reliability for detecting local strains is used. Sometimes in advanced HIV disease when there is severe immunosuppression, antibody levels may be low, resulting in a negative or indeterminate test result.

### Detection of virus

HIV virus tests are available but are very expensive. Antigen tests mainly detect HIV core antigen p24 which is found as long as it is in excess of p24 antibody. This is typically in the early stage of HIV infection (4–7 days prior to seroconversion). In most patients, HIV antigen reappears in the late stages of HIV disease when the level of anti-p24 antibody falls. Nucleic acid tests have also been developed which enable minute amounts of viral material to be detected.

Virus detection tests are mainly performed in specialist virology laboratories. They are used to diagnose HIV infection in newborn infants and to monitor viral load in patients receiving anti-retroviral therapy. Virus testing of donor blood aimed at reducing the 'window' period is not recommended. The window period is likely to be shortened only by about 6 days which therefore provides very little extra safety over antibody testing for the recipients of blood transfusion.

### HIV testing and counselling

Depending on national health policies and available resources, HIV testing is performed:

- For diagnostic purposes whenever a person shows signs or symptoms that are consistent with

HIV-related disease or AIDS. Also to improve patient care and reduce the transmission of HIV from mother to child. HIV testing should be available for all tuberculosis patients.

*Note:* A routine offer of HIV testing by health care providers should be made to all patients being assessed in a sexually transmitted infection clinic, in antenatal clinics and in community based health service settings (including drug rehabilitation centres) where HIV is prevalent, counselling is provided, and antiretroviral treatment is available.

- For individuals and couples to know their HIV status for personal reasons and family-planning, to obtain early advice and HIV-specific care, and to reduce spread of the virus in the community. The use of rapid simple to perform tests is recommended.
- To prevent the transmission of HIV in donor blood and blood products. WHO estimates that 5–10% of global HIV infections are caused by unsafe blood and blood products.
- To monitor the incidence of HIV infection and pattern of spread in the community for surveillance and health management purposes. UNAIDS/WHO do not support mandatory testing of individuals on public health grounds.<sup>3</sup> Voluntary testing is more likely to result in behaviour change to avoid transmitting HIV to others.

Before introducing HIV testing, consideration must be given to the need for counselling and ensuring testing is voluntary, confidential and conducted in a non-stigmatizing environment with informed consent.<sup>4</sup> Individuals must be provided with information on the purpose of testing and on the treatment and support available once the result is known. Assurances must be given that an HIV test result will only be disclosed to the person being offered testing.

### Human rights aspects of HIV testing and counselling<sup>3</sup>

In addressing the human rights aspect of HIV testing and counselling, UNAIDS advises that the voluntariness of HIV testing must remain at the heart of all HIV policies and programmes both to comply with human rights principles and to ensure sustained public health benefits. Other issues include:

- Ensuring an ethical process for conducting HIV testing including defining the purpose of the test and benefits to the individual being tested and assuring an environment that guarantees confidentiality of all medical information.
- Addressing the implications of a positive test result, including non-discrimination and access to sustainable treatment and care.
- Reducing HIV/AIDS-related stigma and discrimination at all levels of health care services.
- Ensuring that there are sufficient trained staff in the face of increased demand for testing, treatment, and related services.

### HIV antibody tests (assays)

A wide range of enzyme linked immunosorbent assays (ELISA) and simple to perform rapid assays for detecting antibodies to HIV-1/HIV-2 are commercially available. Most of the currently available tests have been evaluated by UNAIDS/WHO and the results published in the 2004 Reports: *HIV Assays – Operational Characteristics. Report 14, Simple/Rapid tests*, and *HIV Antigen/Antibody ELISA Assays – Operational Characteristics. Report 15*.

Both reports are available free of charge from UNAIDS, WHO, 1211 Geneva, 27-Switzerland and can be downloaded from the UNAIDS website [www.unaids.org](http://www.unaids.org).

### WHO recommended Strategy for HIV antibody testing

The WHO Strategy for HIV antibody testing to maximize accuracy is summarized in Chart 7.21. It is based on:

- the objective(s) of testing, i.e. whether assay is being performed for diagnostic, blood safety, or surveillance purposes.
- sensitivity and specificity of tests.
- prevalence of HIV infection in the population being tested.

**Chart 7.21 UNAIDS WHO strategy for HIV antibody testing**

<i>Objective of testing</i>	<i>Prevalence of infection</i>	<i>Strategy to use</i>
<b>SAFETY</b>		
Screening blood	All prevalences	1
<b>SURVEILLANCE</b>		
	>10%	1
	≤10%	11
<b>DIAGNOSIS</b>		
• With clinical symptoms of HIV infection	>30%	1*
	≤30%	11
• Asymptomatic	>10%	11
	≤10%	111

\*Only use Strategy 1 when patients meet the WHO criteria for stage 3 or 4 of HIV infection.

*Stage 3:* Intermediate disease with weight loss of more than 10% body weight, unexplained chronic diarrhoea or fever, oral *Candida*, leukoplakia, tuberculosis or severe bacterial infection.

*Stage 4:* Severe disease equivalent to AIDS.

#### Strategy 1

- Test all serum/plasma samples with an ELISA or simple/rapid test of *high* sensitivity which detects both antibody to HIV-1 and HIV-2.
- Report reactive samples as HIV antibody positive.
- Report non-reactive samples as HIV antibody negative.

#### NOTES

- *Screening donor blood:* Blood testing reactive or indeterminate must be considered as probably infected with HIV and *must be discarded*.

Important: Strategy 1 must *not* be used for notifying donors of a positive result. When a donor is to be notified of a test result, the strategies listed under DIAGNOSIS must be applied.

- *Surveillance:* Sensitivity is less crucial for surveillance purposes. The assay chosen should also have a specificity of at least 98%, and it is recommended that the same assay(s) be used over time to monitor fluctuations in HIV prevalence.

#### Strategy 11

- Test all serum/plasma samples with a sensitive ELISA or sensitive simple/rapid test.
- Report samples that are non-reactive as HIV antibody negative.
- Test all reactive samples with a 2nd ELISA or simple/rapid test based on a different test principle or different antigen preparation.
- Report samples that are reactive by both tests as HIV antibody positive.
- Retest with both tests any sample that is reactive by the 1st test but non-reactive by the 2nd test, i.e. Test 1: Positive, Test 2: Negative. If the retested results remain discordant, report the sample as indeterminate.

#### NOTES

- *Indeterminate results:* Samples from patients with stage 3 or 4 of HIV infection (WHO criteria) may give an indeterminate result due to a decreased antibody level. No further testing is normally required.

When there is an indeterminate reaction from an asymptomatic person, collect a second blood sample after a minimum of 2 weeks and retest according to Strategy 11.

- *Surveillance:* No further testing at a later stage is required when an indeterminate result remains after retesting with both tests.

#### Strategy 111 (requires facilities of a Reference laboratory)

This is the same as for Strategy 11 but a 3rd test is needed if after *retesting* the results are as follows:

Test 1: Positive      Test 2: Negative,  
or  
Test 1: Positive      Test 2: Positive

Test the sample using a 3rd test (different test principle or different antigen preparation) and report the results as follows:

Test 1 (Retest)	Test 2 (Retest)	Test 3	Report:
+	+	+	HIV antibody positive
+	—	+	Indeterminate result
+	+	—	Indeterminate result
+	—	—	Report: <ul style="list-style-type: none"> <li>■ Indeterminate if person may have been exposed to HIV infection in previous 3 months, or</li> <li>■ Negative for HIV antibody if person has not been exposed to infection in previous 3 months.</li> </ul>

### Sensitivity and specificity of HIV assays

Sensitivity and specificity are important characteristics which describe the accuracy of HIV antibody assay results.

**Sensitivity:** When using a sensitive assay, i.e. one with a sensitivity greater than 99%, very few samples which contain HIV antibody will be 'missed' because a sensitive test is able to detect low levels of antibody.

When screening donor blood for HIV infection, it is particularly important to use a highly sensitive test to ensure there are very few false negative results. A sensitive assay will help to detect HIV antibody in HIV infected individuals soon after seroconversion.

**Specificity:** This describes the ability of an assay to detect correctly sera that do not contain antibody to HIV.

When diagnosing individuals for HIV infection it is important to use a test of high specificity to minimize the number of persons whose screening test result is positive when they are not HIV infected.

### How prevalence affects the predictive value of HIV assays

When HIV testing for diagnosis, screening (blood donors), and surveillance purposes, the prevalence of HIV infection in an area must also be considered as well as the sensitivity and specificity of assays. The predictive value of a positive HIV assay is low when the prevalence of HIV infection in the population is low and high when the prevalence of infection is high. The higher the positive predictive value, the greater the possibility that a sample giving a positive result means that the person is HIV infected.

### Confirmatory testing

The term confirmatory, or supplementary, testing refers to the retesting of an HIV antibody positive sample by another assay having a different test principle or method of antigen preparation. Confirmatory assays are required to investigate indeterminate results for diagnostic purposes.

### ELISA (enzyme linked immunosorbent assay)

ELISAs are used mainly for screening blood in regional blood transfusion centres and testing samples in HIV surveillance work. The microplate format of the ELISA enables large numbers of samples to be tested cost-effectively. ELISAs are less suitable for use in district laboratories where the number of HIV tests are usually few with less opportunity for batching of tests, power supplies (needed to run the equipment) are less stable and district laboratory staff may not have the training and experience to perform and interpret ELISAs and maintain the equipment, particularly ELISA microplate readers.

*Note:* Manufacturer's instructions for performing an ELISA must be followed exactly including washing instructions. Problems can be caused both by underwashing and excessive washing. All tests must be adequately controlled and also the performance of ELISA microplate readers.

### Simple rapid HIV antibody assays (tests)

HIV antibody tests that are simple to perform and give results in under 10 minutes ('rapid tests') are becoming increasingly used in diagnosis and for small scale screening of donor blood. Many of these tests have sensitivities and specificities equal to ELISAs and can often be performed more reliably than ELISAs, providing the manufacturer's instructions are followed exactly and controls are used. Simple/rapid assays are designed for testing individual samples (often using whole blood as well as serum or plasma), can be read visually without the need for a reader, are easy to perform and interpret, reagents are usually supplied ready to use, and most assays have good stability. Many rapid tests can be stored at ambient temperatures (up to 28°C). Most devices have a 'built-in' control. Simple rapid tests include:

- agglutination tests, performed in a testing device or on a slide
- strip (dipstick) and comb-type tests
- flow-through membrane tests
- lateral flow immunochromatographic tests

Depending on the type of test, a positive result is indicated by an agglutination reaction or the appearance of a coloured dot or line.

Examples of simple rapid assays with high sensitive and specificities include:

- *Capillus HIV-1 HIV-2 agglutination assay\**
- *Uni-Gold HIV 1 and 2 immunochromatographic test\**
- *SD Bioline HIV 1/2 3.0 immunochromatographic test\**

● *Determine HIV 1/2 immunochromatographic test\**

\*These assays are included in the WHO Bulk Procurement Scheme which enables tests to be purchased economically by AIDS programmes. Information about the Scheme, cost and specifications of assays and technical information can be obtained from *Procurement Services*, World Health Organization, 1211 Geneva 27, Switzerland. Phone +41 22 791 2801. Fax +41 22 791 4196. E-mail: procurement@who.int. The list of available assays can be downloaded from WHO website www.who.int (use Search facility to locate list).

**Capillus HIV-1/HIV-2 assay**

The *Capillus HIV-1/HIV-2* test is a simple rapid agglutination test, manufactured by Trinity Biotech (see Appendix 11). It is available as a 20 test or 100 test kit. The latex reagents and controls require storage at 2–8 °C.

*Test method*

*Capillus HIV-1/HIV-2* uses recombinant antigen derived from HIV-1 env (envelope) and HIV-2 env genes to detect antibody to HIV-1 and/or HIV-2 in serum, plasma, or whole blood. The test is performed in a plastic capillary slide consisting of: a well in which the latex antigen reagent is mixed with the sample (10 µl), a channel along which the mixture flows by capillary attraction, and a viewing chamber at the end of the channel (see Fig 7.35).

A drop of the latex antigen reagent is mixed with a drop of sample in the mixing well and the mixture is drawn through the channel. When the mixture reaches the viewing chamber, the result can be read visually.

A reactive test is shown by agglutination of the HIV antigen coated latex particles, as shown in colour Plate 77. No agglutination indicates a negative test. Positive and negative controls are supplied with each kit. Although a battery operated *Capillus Reader* is available for reading the reactions this is optional and not essential.

*Capillus HIV-1/HIV-2* has been evaluated extensively in developing countries and also by UNAIDS. It performs with a high degree of accuracy. Most evaluations report 100% sensitivity and 98–99% specificity.

**Uni-Gold HIV 1 and 2 test**

*Uni-Gold HIV* is an immunochromatographic test in cassette form that detects antibodies to HIV-1 and/or HIV-2 in whole blood, serum or plasma using recombinant HIV-1 and HIV-2 antigens. It is an HIV-1, HIV-2 combined test. It is manufactured by Trinity Biotech (see Appendix 11) and is available as a 20 test kit. Test devices and wash solution do not require refrigeration. They can be stored up to 27 °C.

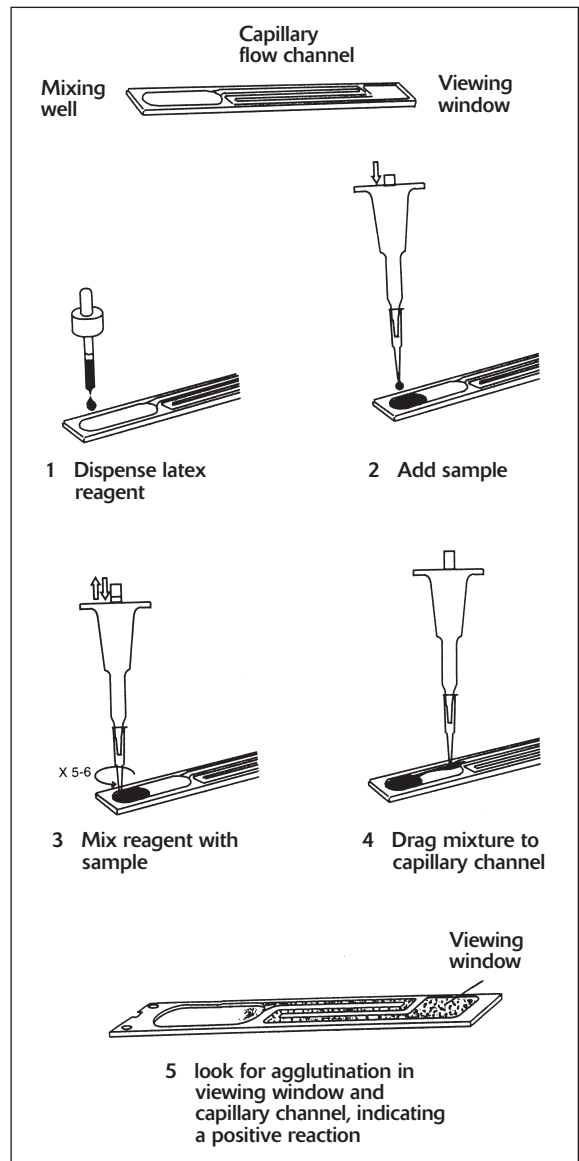

Fig 7.35 *Capillus HIV-1/HIV-2* agglutination assay to detect antibody to HIV-1 and HIV-2 using serum or whole blood. For test results, see colour Plate 78.

Courtesy of Trinity Biotech.

*Test method*

The principle of immunochromatographic antibody tests is described on p. 18. Two drops (approx. 60 µl) whole blood, serum or plasma is added to the sample port using the pipette supplied, followed by two drops of wash buffer. Test results are read after 10 minutes (the reaction is stable for up to 20 minutes).

A positive HIV antibody test result is shown by a

pink line in the Test (T) area and a pink line in the control (C) area as shown in Fig. 7.36 and colour Plate 79. A negative HIV test result is shown by a pink line in the control (C) area only. This shows that the reagents have performed satisfactorily.

*Uni-Gold HIV* has been extensively evaluated. It has been reported as having a sensitivity of 100% and specificity of 99.7–100%.

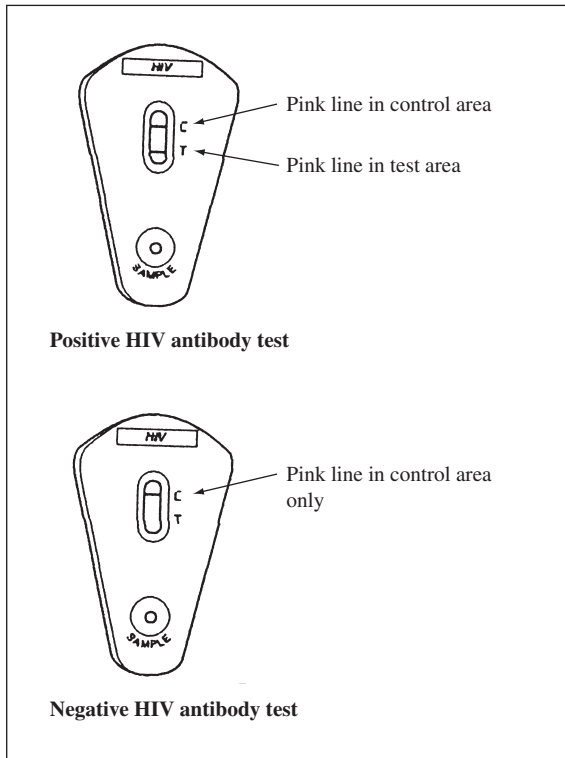

Fig 7.36 *Uni-Gold HIV* test results. See also colour Plate 79. Courtesy Trinity Biotech.

### ***SD Bioline HIV 1/2 3.0* test**

*SD Bioline HIV 1/2 3.0* is a third generation immunochromatographic test in cassette form that detects separately antibodies to HIV-1 and/or HIV-2 in whole blood, serum or plasma using recombinant HIV-1 and HIV-2 antigens. It is manufactured by Standard Diagnostics Inc. (see Appendix 11) and is available as a 30 test kit. The test can be stored at ambient temperature (up to 30°C).

#### *Test method*

The principle of immunochromatographic antibody tests is described on p. 18. In the test, 20 µl whole

blood or 10 µl serum or plasma is added to the sample well followed by 4 drops of assay diluent. Test results are read at 5–10 minutes when using whole blood and at 5–20 minutes when using serum or plasma.

A positive test result for HIV-1 antibody is shown by a pink line in test area 1 and a pink line in the control (C) area. A positive test result for HIV-2 antibody is shown by a pink line in test area 2 and a pink line in the control (C) area. The presence of a colour line in the control area only indicates a negative test for HIV-1 and HIV-2 antibody. It shows that the reagents have performed satisfactorily. Test results are shown in Fig. 7.37 and colour Plate 80.

In a recent UNAIDS evaluation (Report 14, 2004), *SD Bioline HIV 1/2* was shown to have a sensitivity of 100% and specificity of 99.3%.

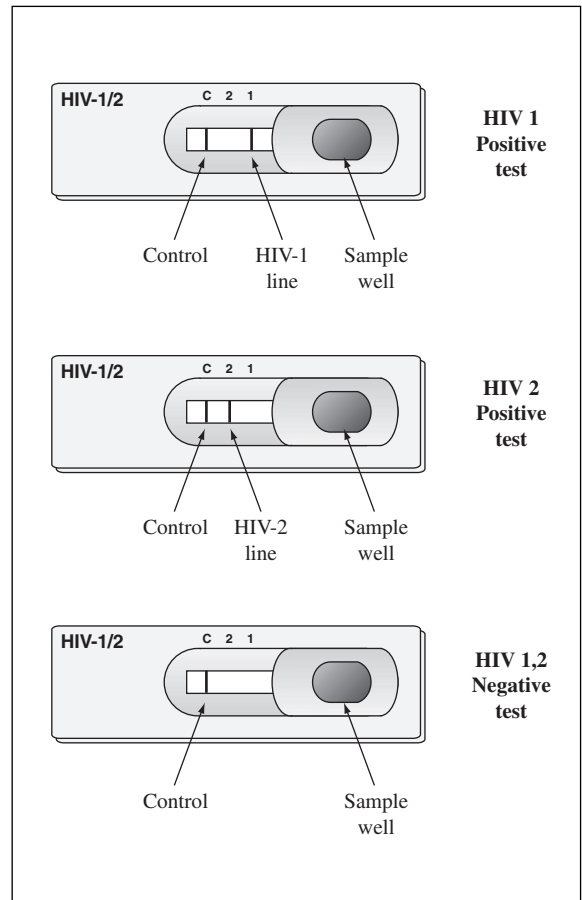

Fig 7.37 *SD Bioline HIV 1/2 3.0* test results. See also colour Plate 80.

**Determine HIV-1/2 test**

*Determine HIV-1/2* is an immunochromatographic test in mounted strip form that detects antibodies to HIV-1 and/or HIV-2 in whole blood, serum or plasma using recombinant HIV-1 and HIV-2 antigens. It is an HIV-1, HIV-2 combined test. It is manufactured by Abbott Diagnostika (see Appendix 11) and is available as a 20 and 100 test kit. Test devices can be stored at ambient temperature (up to 30°C).

**Test method**

In the test, 50 µl of sample is placed on the sample application pad. When using whole blood, one drop of buffer (supplied with the kit) is added. Test results are read after 15 minutes.

A positive HIV antibody test result is shown by a pink line in the Patient test area and a pink line in the Control area. The presence of a pink line in the Control area only indicates a negative HIV antibody test. It shows that the reagents have performed satisfactorily. Test results are shown in Fig. 7.38.

*Determine HIV-1/2* has been shown to have excellent performance characteristics. Evaluations in sub-Saharan Africa, Vietnam, Dominican Republic, Honduras and Mexico have shown the test to have 99.4–100% sensitivity and 99.6–100% specificity.

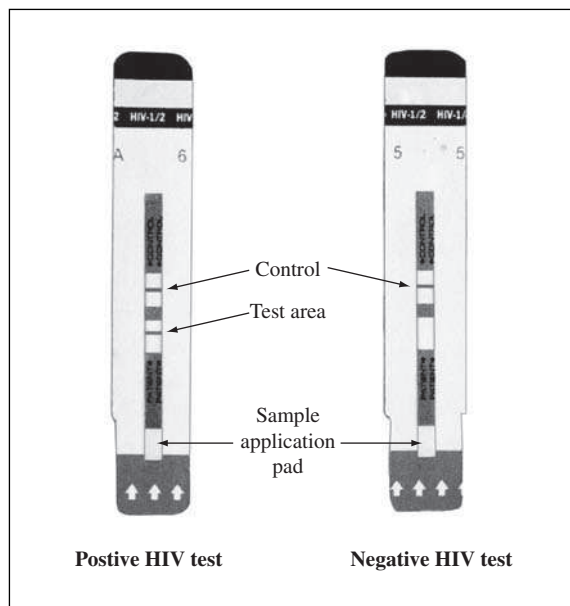

Fig 7.38 *Determine HIV-1/2* test results

**Important considerations when performing HIV testing in district laboratories**

- Define the objective(s) of HIV antibody testing and the testing strategy to be followed when screening blood,\* surveillance testing, and diagnostic testing (see previous text).

\*See subunit 9.2 regarding the selection of donors in HIV endemic areas.

- Provide support with pre-test and post-test counselling when performing diagnostic testing.<sup>4</sup>
- Purchase test kits from reliable sources and select tests of appropriate sensitivity and specificity (according to testing objectives) that will detect local HIV strains and can be performed reliably, controlled adequately, and interpreted correctly. Ensure staff receive sufficient training and supervision and whenever possible arrange for external quality assessment.
- Establish safe working practices for collecting and handling specimens and safe procedures for decontaminating and disposing of specimens and recycling contaminated articles as explained in subunits 3.3 and 3.4 in Part 1 of the book.

**Important:** Avoid needlestick injury (never resheat needles). Dispose of 'sharps' (needles, lancets) into a tin or thick plastic box that cannot be pierced and will not leak. Do not use chipped glassware. HIV is inactivated by heat (few seconds at 100°C) and by chlorine releasing compounds such as NaDCC or hypochlorite solutions (see subunit 3.4 in Part 1 of the book). Well documented studies show no increased risk to laboratory personnel of acquiring HIV through routine laboratory work when applying good laboratory practice.

**Laboratory monitoring of antiretroviral treatment**

While not a cure for HIV infection, antiretroviral drugs, by reducing viral activity, have been shown to improve the health, quality of life and survival of HIV infected people and to reduce mother to child transmission of HIV. Nationally and internationally, efforts

are being intensified to ensure antiretroviral therapy (ART) becomes accessible to all those who need it, together with the clinical care and support required.<sup>5</sup>

#### Antiretroviral drugs

Currently the main groups of drugs that are used in ART are:

- Reverse transcriptase inhibitors (RTIs) which include:
  - Nucleoside reverse transcriptase inhibitors (NsRTIs), e.g. zidovudine (AZT, ZDV), didanosine (ddl), stavudine (d4T), lamivudine (3TC), abacavir (ABC), zalcitabine (ddC), emtricitabine (FTC)
  - Non-nucleoside reverse transcriptase inhibitors (NNRTIs), e.g. nevirapine (NVP), efavirenz (EFV), delavirdine (DLV)
  - Nucleotide reverse transcriptase inhibitors (NtRTIs), e.g. tenofovir (TDF).
- Protease inhibitors (PIs), e.g. saquinavir (SQV), ritonavir (RTV), indinavir (IDV), nelfinavir (NFV), lopinavir/ritonavir (LPV/r), amprenavir (APV), atazanavir (reyataz).

A combination of drugs needs to be taken lifelong for continued effectiveness and to prevent the emergence of drug-resistant HIV strains. Combined treatment is referred to as highly active antiretroviral therapy (HAART) and consists of a combination of at least three antiretroviral drugs, usually two NsRTIs, and a NNRTI. WHO revised (2005–2006) ARV drug regimens for use in resource-limited settings are shown in Table 1.

The combination of drugs selected for first-line ARV regimens will depend on national ART policies, effectiveness of drug combination, co-existing conditions, e.g. tuberculosis or pregnancy, known drug toxicities and drug interactions, simplicity of regimens for patients and health personnel (e.g. fixed dose combinations), anticipated patient adherence, laboratory monitoring required, local cost of drugs and their availability.

Information on first and second line ARV regimens for adults, adolescents, and children, drug doses and other aspects of ART can be found in the WHO publication *Scaling up of antiretroviral therapy in resource-limited settings: Treatment guidelines for a public health approach*. World Health Organization, Geneva, 2004. The publication can be downloaded from the WHO website [www.who.int/hiv](http://www.who.int/hiv). A revision of this document is currently underway. Refer to website [www.who.int/3by5](http://www.who.int/3by5) (use Search facility to locate 2005–2006 Guidelines).

#### Adverse effects of antiretroviral drugs

In countries where ART is only just being introduced, e.g. in sub-Saharan Africa, Asia and elsewhere, information on the short-term and long-term effects of antiretroviral drugs is incomplete and therefore careful clinical monitoring is required. The

WHO 3 by 5 Initiative website and WHO HIV website are important sources of up to date information on ARV drugs, their effectiveness and toxicities.

#### Known adverse effects associated with NsRTIs, NNRTIs and PIs classes of drugs<sup>6</sup>

- *NsRTIs*: Fatty changes in the liver, lactic acidosis, lipotrophy with prolonged use.
- *NNRTIs*: Skin reactions (can be severe), abnormal liver enzymes/hepatitis.
- *PIs*: Lipotrophy, elevated serum cholesterol and triglycerides, elevated blood glucose, bleeding episodes in patients with haemophilia.

#### Table 1 Revised first line ARV regimens for adults and adolescents

In the WHO 2005–2006 revision of *Antiretroviral drugs for the treatment of HIV infection in adults and adolescents in resource-limited settings*, the following first line ARV regimens have been proposed:

- (AZT or d4T) + (3TC or FTC) + (EFV\* or NVP)
- TDF + (3TC or FTC) + (EFV\* or NVP)
- ABC + (3TC or FTC) + (EFV\* or NVP)
- (AZT or d4T) + (3TC or FTC) + (ABC or TDF).

\*Due to its possible teratogenicity, EFV should not be given to pregnant women.

**Abbreviations:** AZT = Zidovudine, d4T = Stavudine, 3TC = Lamivudine, FTC = Emtricitabine, EFV = Efavirenz, NVP = Nevirapine, TDF = Tenofovir, ABC = Abacavir

*Note:* The ARV regimen d4T + 3TC + NVP is available as a three-drug fixed dose combination.

#### Drugs that require laboratory monitoring during ART

- AZT causes bone marrow suppression (anemia, neutropenia). Laboratory monitoring includes measurement of haemoglobin, total WBC count and differential.
- d4T is associated with peripheral neuropathy, pancreatitis and lipotrophy. When indicated measurement of serum or plasma amylase and/or lipids may be required.
- NVP is hepatotoxic and causes skin rashes which may be life threatening. Laboratory monitoring includes measurement of serum alanine aminotransferase (ALA).
- TDF is reported as causing renal damage. Laboratory monitoring includes measurement of serum creatinine and urinalysis.

#### Patients with tuberculosis and HIV

Recommended ARV regimens can be found in the WHO publication *TB/HIV: A Clinical Manual*.<sup>6</sup> Potential drug interactions between rifampicin and NNRTIs and PIs may result in ineffectiveness of ARV drugs, ineffective treatment of tuberculosis, or an increased risk of drug toxicity. Whenever



possible, ART should be deferred until completion of the rifampicin phase of tuberculosis treatment.

#### Patients infected with HIV-2 or HIV-1 group 0 strains

ARV regimens need to be modified due to insensitivity to NNRTIs as discussed in the WHO publication *Scaling up antiretroviral therapy in resource-limited settings*.<sup>5</sup>

#### Laboratory testing at the commencement of ART

The decision when to commence ART is a clinical one\* made in consultation with the patient with the help of basic laboratory investigations.

\*Clinical assessment includes staging of HIV disease, determining other existing conditions (e.g. tuberculosis, pregnancy, major psychiatric illness), identifying other medications including traditional therapies, body weight, assessment of patient's readiness for ART.

When available it is usual to perform a CD4 T lymphocyte count and ideally also a plasma HIV RNA assay (viral load test). Such investigations are not usually possible in district laboratories but it may be possible to send samples for testing\* to the Regional laboratory or other laboratory equipped to perform these tests.

\*District laboratories should consult with the laboratory performing CD4 counting as regards the sample required and the use of an appropriate cell preservative, e.g. *Cyto-ChexBCT* or *TransFix*.

*When a CD4 count is available:* WHO recommends commencing ART in adults and adolescents at clinical stage 1, 2 or 3 when the CD4 count is less than 200/ $\mu$ l. ART should be commenced in all patients with AIDS (clinical stage 4) irrespective of CD4 count.

*When a CD4 count is not available:* WHO recommends commencing ART in patients at clinical stage 2 when the total lymphocyte count is less than  $1.2 \times 10^9/l$  (1200/mm<sup>3</sup>). ART should be commenced in all patients at clinical stage 3 and 4 irrespective of the lymphocyte count.

**Clinical staging of HIV infection:** Details can be found in the WHO publication *Scaling up of antiretroviral therapy in resource-limited settings*.<sup>5</sup>

In addition to a CD4 count or total lymphocyte count other baseline tests include:

- Pregnancy test, to ensure pregnant women are not treated with efavirenz (EFV).
- Haemoglobin or PCV and WBC count to obtain baseline values and to ensure anaemic leucopenic patients are not treated with zidovudine (AZT).
- Alanine aminotransferase (ALA) to give a baseline value when an AVR regimen includes

drugs known to cause hepatotoxicity (liver cell damage) such as nevirapine (NVP).

- Serum creatinine to give a baseline value when an ARV regimen includes drugs known to cause renal damage, such as tenofovir (TDF).
- Sputum smear, for AFB to ensure patients with tuberculosis receive appropriate ART.

*Note:* Also included as baseline tests by some laboratories are routine urinalysis and measurement of serum albumin as an indicator of liver function and nutrition.

#### Laboratory monitoring of ART in district laboratories

The tests performed and frequency of testing will depend on the ARV regimen being used, the clinical signs and symptoms that present during ART and available resources. They include:

- CD4 count when available (through Regional laboratory) at 6 monthly intervals.
- Haemoglobin or PCV, total white cell count and differential every 1–2 months. Rapid life-threatening falls in haemoglobin can occur when patients are being treated with AZT.
- ALA every 6 months or more frequently when liver cell damage is suspected.
- Serum creatinine and urinalysis every 6 months or more frequently when indicated to monitor renal function, particularly when an ARV regimen contains a nephrotoxic drug such as TDF.
- Pregnancy test when clinically indicated and the ARV regimen includes efavirenz.

Additional tests which may be clinically indicated during ART include:

- Serum or plasma amylase
- Blood glucose
- Serum or plasma bilirubin
- Serum cholesterol and lipids.

*Note:* WHO recommends a realistic approach to laboratory monitoring of ART in consideration of the urgent need to extend ART to HIV infected persons in resource-limited settings. As more information becomes available on the adverse effects of antiretroviral drugs in HIV infected patients in developing countries, it will become clearer which investigations are needed for efficacy and safe-monitoring of ART. Laboratory monitoring will also need to be reviewed when new antiretroviral drugs

become available. Readers are referred to WHO 3 by 5 Initiative website: [www.who.int/3by5](http://www.who.int/3by5).

#### REFERENCES

- 1 UNAIDS/WHO *AIDS epidemic update, December 2004*. Available from UNAIDS, WHO, 1211 Geneva 27, Switzerland. Can be downloaded from UNAIDS website [www.unaids.org](http://www.unaids.org)
- 2 **Veazey RS, Lackner A.** HIV swiftly guts the immune system. *Nature Medicine* 11, pp. 469–470, 2005.
- 3 UNAIDS/WHO. *UNAIDS/WHO Policy statement on HIV testing*, June 2004. Can be downloaded from UNAIDS website [www.unaids.org](http://www.unaids.org)
- 4 WHO *Rapid HIV tests: Guidelines for use in HIV testing and counselling services in resource-constrained settings*, 2004. Available from Dept HIV/AIDS, WHO, 1211 Geneva 27, Switzerland. Can be downloaded from WHO HIV website [www.who.int/hiv](http://www.who.int/hiv)
- 5 WHO. *Scaling up antiretroviral therapy in resource-limited settings: Treatment guidelines for a public health approach*, WHO, Geneva, 2004. Can be downloaded from WHO HIV website [www.who.int/hiv](http://www.who.int/hiv)
- 6 WHO. *TB/HIV: A Clinical Manual*, 2nd edition, 2004. Available from Marketing and Dissemination, WHO 1211 Geneva 27, Switzerland.

#### FURTHER INFORMATION

In addition to the publications listed in the references, readers are also referred to:

UNAIDS/WHO *HIV assays: Operational characteristics (Phase 1), Report 14 Simple/rapid tests*, 2004. Available from Essential Health Technologies (EHT), WHO, 1211 Geneva 27, Switzerland. Can be downloaded from EHT website [www.int/ehf](http://www.int/ehf)

UNAIDS/WHO *HIV antigen/antibody assays: Operational characteristics, Report 15*, 2004. For availability, see above.

WHO. *Antiretroviral drugs for treating pregnant women and preventing HIV infection in infants*, WHO, 2004. Can be downloaded from WHO HIV website [www.who.int/hiv](http://www.who.int/hiv)

UNAIDS/WHO *HIV/AIDS and young people: Hope for tomorrow*, UNAIDS, 2004. Obtainable from UNAIDS Information Centre, V Building, Office 102, 20 Avenue Appia, 1211 Geneva 27, Switzerland. E-mail [unaids@unaids.org](mailto:unaids@unaids.org)

UNAIDS/WHO *National AIDS Programmes: A guide to monitoring and evaluating HIV/AIDS care and support*, UNAIDS, 2004. For ordering, see above listing.

**Bain BJ.** The haematological features of HIV infection. *British Journal Haematology*, 99, pp. 1–8, 1997.

**Chimzizi R, Harries A.** Delivering highly active ARV therapy to patients with tuberculosis at district level in sub-Saharan Africa. *Mera*, March 2004.

**Chimzizi RB et al.** Use of a monitoring tool to assess counselling and HIV testing in the public health sector in Malawi. *Tropical Doctor*, April 2005.

**Badri M, Wood R.** Usefulness of total lymphocyte count in monitoring highly active antiretroviral therapy in resource-limited settings. *AIDS*, 17(4), pp. 541–5, 2003.

WHO *Managing antiretroviral side effects: A Practical Guide*. HIV/AIDS Antiretroviral Newsletter, Issue No. 10, December 2003. WHO Regional Office for the Western

Pacific. Can be downloaded from WHO website [www.who.org](http://www.who.org) (use Search facility to locate Newsletter).

**Wegelin-Schuringa M et al.** Techniques and practices for local responses to HIV/AIDS. KIT publishers, Amsterdam, 2004.

**Evian C.** *Primary HIV/AIDS care*, 2005. Macmillan Education (available from TALC, PO Box 49, St Albans AL1 5TX, UK. E-mail [info@talcuk.org](mailto:info@talcuk.org) Website [www.talcuk.org](http://www.talcuk.org)).

**Narain JP.** AIDS in Asia: The challenge ahead, WHO/SEARO publication 2004. Obtainable from WHO/SEARO, e-mail [webmaster@whosea.org](mailto:webmaster@whosea.org)

**Amirali W et al.** Assessment of clinical case-definition for HIV/AIDS in Tanzania. *East African Medical Journal*, Vol. 81, No. 5, May 2004.

Reviews: Bacterial disease in HIV-infection. Papers included in *Tropical Doctor*, 34, October 2004, pp. 195–208.

Wellcome Trust CD-ROM: *Topics in international health – HIV/AIDS revised edition*, 2003. Available from TALC (see above for ordering information).

*Strategies for Hope Series*, booklets 1–16. Action Aid. Available from TALC (see above for ordering information).

#### WEBSITES

- UNAIDS/WHO website: [www.unaids.org](http://www.unaids.org)
- WHO 3 by 5 Initiative website: [www.who.int/3by5](http://www.who.int/3by5)
- WHO HIV website: [www.who.int/hiv](http://www.who.int/hiv)
- Southern Africa AIDS information dissemination service (SAFAIDS) website: [www.safaims.org.zw](http://www.safaims.org.zw)
- Avert HIV/AIDS website: [www.avert.org](http://www.avert.org)
- AMREF HIV/AIDS, Tuberculosis, STIs programme information website: [www.amref.org](http://www.amref.org)
- International HIV/AIDS Alliance website: [www.aidsalliance.org](http://www.aidsalliance.org)
- HIV/AIDS in India website: [www.aids-india.org](http://www.aids-india.org)
- WHO South-East Asia regional office HIV/AIDS website: [www.whosea.org/aids](http://www.whosea.org/aids)
- Brazilian AIDS association website: [www.abiaids.org](http://www.abiaids.org)

### Acknowledgements Colour Section

Gratitude and thanks are expressed to all those who originated artwork and loaned personal transparencies to produce the Plates for this colour section.

Mr Alan Westley and the Medical Photography Unit, Addenbrooke's Hospital, Cambridge, for producing Plates 1 and 5.

Mr Raymond W Davies for preparing and photographing Plates 2, 4, 8, 9, 11, 12, 14, 16, 26, 27, 29, 36, 39, 40, 42, 49, 50, and 52.

Dr Tito Avarado for supplying artwork for Plate 6.

Dr ETM Smyth for supplying transparencies for Plates 32, 33, 55, and 65.

Dr John V Lee for permission to reproduce Plate 10.

Mr Joseph V Franco for originating and photographing Plates 13, 53, and 59 and supplying a microscope slide preparation for the production of Plate 57.

Dr Martin B Skirrow for supplying artwork for Plates 15 and 17.

Mr Michael Amphlett and the Medical Photography Unit, Addenbrooke's Hospital, Cambridge for producing Plates 18 and 19.

Wagtech International for permission to reproduce Plate 20.

World Health Organization for permission to reprint Plate 21 from *Analysis of wastewater for use in agriculture*, 1996, Plate 41 from *Laboratory diagnosis of sexually transmitted diseases*, 1999, and Plate 60 from *Handbook of endemic treponematoses*, 1984.

Mr George Sinton for supplying artwork for Plate 22.

Dr Trevor Willis for supplying transparencies for Plates 24, 25, and 35.

Mr Alan W Cremer for supplying artwork for Plate 30.

Oxoid Ltd for providing artwork for Plates 31 and 51.

Professor PJ Fripp for supplying artwork for Plate 44.

Professor D Banerjee for providing transparencies for Plates 45 and 47.

Dr John Richens for supplying artwork for Plate 46.

Dr Jane Carter and AMREF for providing transparencies for Plate 56 left, Plate 58, and Plate 64 right.

Professor P Phanuphak for supplying artwork for Plate 71.

Professor Wallace Peters for permission to reproduce Plate 66.

Dr Henk Smits for originating and supplying artwork for Plate 63.

*British Journal of Ophthalmology* for permission to reproduce Plate 67.

Dr YM Clayton and Institute of Dermatology, London, for supplying artwork for Plate 70.

Medical Microbiology Dept, University of Leeds for supplying artwork for Plates 73 and 75.

Mrs Elizabeth Gerwing-Adima for supplying a microscope preparation to originate Plate 74.

Professor Y Yoshida for supplying artwork for Plate 76.

Mr Anthony Moody for supplying artwork for Plate 77.

Trinity Biotech for providing artwork for Plate 78.

Churchill Livingstone for permission to reprint Plate 86 from *Practical Haematology* by JV Dacie and SM Lewis, p. 123, 1995.

Dr Drew Provan for supplying artwork for Plate 90.

Dr Imelda Bates for providing artwork for Plates 108, 111, 112 (originals: Dr Parker Williams).

Mrs Mary Popeck for producing and photographing Plate 101.

Blackwell Science for permission to reprint Plate 107 from *Essential Haematology* by AV Hoffbrand and JE Pettit, p. 85, 1993.

# 8

## Haematological tests

### 8.1 Haematology in district laboratories and quality assurance

Many diseases prevalent in tropical countries produce blood cell changes which can be detected in laboratory tests. At district level a few inexpensive tests when reliably performed can provide information of value in diagnosis and treatment. Haematological tests are mainly used:

- To investigate anaemia,
- To investigate infections and pyrexia (fever) of unknown origin (PUO),
- To investigate clinically important haemoglobinopathies,
- To monitor patients receiving antiretroviral therapy (ART).

Occasionally tests to investigate a bleeding disorder are required although the facilities of a specialist centre will be needed to diagnose and monitor a coagulation disorder. A hospital with a specialist haematology laboratory and treatment facilities will also be required to diagnose and treat major blood cell disorders. A white cell count and examination of a blood film in a district laboratory, however, may provide the first indication that a patient has leukaemia or myelomatosis.

#### Haematological tests performed in district laboratories

Depending on local health needs, resources, and availability of trained staff, the following are among the haematological tests performed in district laboratories:

<i>Test</i>	<i>Subunit</i>
■ Measurement of haemoglobin and basic investigation of anaemia	8.4
■ Measurement of packed cell volume and calculation of red cell indices	8.5

■ White blood cell (WBC) count	8.6
■ Platelet count	8.6
■ Differential WBC count	8.7
■ Reporting blood films: red cells, white cells, platelets	8.7
■ Erythrocyte sedimentation rate	8.8
■ Reticulocyte count	8.9
■ Investigation of sickle cell disease	8.10
■ Blood film appearances in thalassaemia syndromes	8.2
■ Haemoglobin electrophoresis	8.10
■ Screening test for G6PD deficiency	8.9
■ Examination of imprint smears for Burkitt's lymphoma cells	8.2
■ Tests to screen for a bleeding disorder	8.11

*Note:* Reasons for carrying out different tests, interpretation of test results, and reference ranges for quantitative tests are included in subsequent subunits describing the different tests.

#### QUALITY ASSURANCE IN HAEMATOLOGY

The importance and implementation of quality assurance (QA), quality management, and standardization to achieve reliable test results and a quality service to patients, are described in chapter 2 in Part 1 of the book. QA and good laboratory practice are also required to ensure a safe working environment and cost-effective use of resources.

Implementing QA in haematology requires the preparation and use of *Standard Operating Procedures* (SOPs) for all haematological tests and associated activities.

#### Standard operating procedures

SOPs are written, up to date instructions and information which cover in detail not just how to perform individual tests but also what needs to be considered at a *local level* to ensure the correct use, availability, reliability, timeliness and reporting of blood tests and correct interpretation of test results. An SOP needs to include:

- Value of test, i.e. reasons for performing it.

- Principle of test, i.e. type of technology used.
- Specimen details, including volume required, container to use, collection technique, labelling, storage, stability, checks to be made when a specimen and request form reach the laboratory.
- Equipment required: its use, performance checks, cleaning, maintenance and source of replacement parts.
- Reagents or stains used: ordering information, details of preparation, control, storage, shelf-life, and any associated hazard, e.g. toxic, flammable, corrosive.
- Control materials, source, use, and storage.
- Method of test including details of procedure, calculations, quality control (QC), safety considerations.
- Sources of error.
- Reporting test result, i.e. format, units used, calculation(s).
- Verification of test result and action to take when a result is seriously abnormal or unexpected.
- Interpretation of test result and when indicated, a reference range.
- Information on the cost of a test, e.g. high, medium, low.

SOPs are important in maintaining a high quality of service to patients. They promote competence and motivation of staff and confidence in the reliability of test results by users of the laboratory. SOPs are also a valuable training tool. Further information on SOPs can be found on pp. 32–34 in Part 1 of the book.

#### *Detecting errors which can lead to incorrect test results*

Effective QA detects errors at an early stage before they lead to incorrect test results. Laboratory personnel need to be aware of errors that can occur when:

- collecting blood specimens (pre-analytical stage),
- performing blood tests (analytical stage),
- reporting tests and interpreting test results (post-analytical stage),

#### **Pre-analytical stage**

QA in the pre-analytical stage includes:

- Appropriate use of haematological investigations.
- Collection, storage and transport of blood specimens.
- Checks to be made when the specimen and

request form reach the laboratory.

#### *Appropriate use of haematological investigations*

Clear guidelines must be provided on the use of haematological tests to avoid unnecessary tests being undertaken, e.g. there should be clear clinical indications for requesting a white cell count and differential cell count.

In some situations the result of a particular test will indicate further tests to perform which the laboratory should undertake routinely, e.g. tests to investigate anaemia when the result of a haemoglobin test indicates moderate or severe anaemia, tests to detect haemoglobin S when examination of a blood film suggests sickle cell disease, or measurement of haemoglobin when examination of a thick blood film shows many malaria parasites and the patient is a young child.

#### *Collection, storage and transport of blood specimens*

Techniques for the correct and safe collection of capillary and venous blood samples are described in subunit 8.3. Errors associated with the collection and storage of blood samples which can lead to incorrect test results include:

- Collecting blood from the wrong patient which can easily occur when there is a language difficulty and laboratory staff do not check the patient's identification number.
  - Using a wet syringe and needle when collecting venous blood or not removing the needle from a syringe before dispensing the blood, resulting in haemolysis.
  - Collecting blood from an arm into which an intravenous (IV) infusion is being given, resulting in a diluted sample.
  - Applying a tourniquet too tightly or for too long a period leading to venous stasis and false increase in the concentration of haemoglobin and other substances in the blood.
  - Dispensing venous blood into a container with insufficient anticoagulant or inadequate mixing of the blood with the anticoagulant, resulting in clots in the sample. Difficulty in obtaining blood can also cause clot formation.
- Note:* Anticoagulants are described in subunit 8.3.
- Not adding sufficient blood to anticoagulant in a container, allowing too long a delay before testing the blood, or leaving the blood at high ambient temperature or in direct sunlight before testing it, resulting in physical, chemical, and

morphological blood cell changes.

- Incorrect technique when collecting capillary blood, particularly excessive squeezing of a finger or infant's heel, resulting in the sample being diluted with tissue juice.
- Using a wet or chipped pipette to collect capillary blood.

*Checks to be made when a specimen reaches the laboratory*

Each specimen must be accompanied by a request form which provides details of the patient (name, age, gender, inpatient or outpatient number, ward when an inpatient, home area or village), patient's illness, i.e. clinical note, and the date and time the specimen was collected.

Laboratory staff must check that the name/number on the specimen container or blood slide is the same as that on the request form. A specimen must not be accepted if it is unlabelled, incorrectly labelled, or is obviously not suitable for testing, e.g. clotted blood in an anticoagulated container, or when there is evidence of sample leakage.

*Note:* In district laboratory practice, many blood specimens will be capillary samples collected from children or antenatal patients for measuring haemoglobin. Laboratory staff must ensure that these specimens are clearly labelled and can be matched to the patient's details on their outpatient card.

**Analytical stage**

Common errors in the analytical stage of performing haematological tests which can lead to incorrect test results include:

- *Inadequate mixing of blood sample:* Before testing anticoagulated venous blood it *must* be mixed thoroughly, manually or preferably on a mixer for 2–5 minutes.
- *Not using controls and quality control chart to check the performance of quantitative tests:* Preparation and use of a Quality Control Chart to monitor the performance of a quantitative test (e.g. measurement of haemoglobin), are described on pp. 323–328 in Part 1 of the book.

**Stabilized whole blood control and haemolysate for internal quality control of haematological tests**

These should be prepared and calibrated in the Regional Hospital or Central Hospital haematology laboratory and distributed by the District Laboratory Coordinator to district laboratories. Details of how to prepare and cali-

brate a stabilized whole blood control (with 2–3 y stability), inexpensively from CPD or ACD anticoagulated blood and also haemolysate (with several years stability) can be found in the WHO document *Quality Assurance in Haematology* (see Further information).

- *Pipetting errors:* Inaccurate and imprecise pipetting of blood are major causes of incorrect haemoglobin and blood cell count test results, e.g. not wiping blood from the outside surface of a pipette tip and not rechecking whether the blood is on the graduation line of the pipette before dispensing it (see illustration in subunit 8.4). Using an incorrect volume of blood can also occur when a wet pipette or one with a chipped end is used.
- *Errors in the preparation and staining of blood films;* It is particularly important to standardize the preparation and staining of thin blood films because in the absence of other tests, the blood film report is particularly important when investigating anaemia at district level.

The following are the main causes of poorly made, inconsistent and poorly stained thin blood films which can result in misleading or incorrect blood film reporting:

- not using a clean grease-free slide or smooth edged spreader.
- inexperience in spreading a blood film.
- high humidity causing lysis of red cells prior to fixation.
- water present in the methanol used to fix the film.
- poor quality stain, incorrect preparation of the stain, or water in the stock stain.
- use of unsuitable water to prepare the buffered water and not checking its pH, resulting in films appearing too 'red' or 'blue'.
- variable staining time.
- incorrect staining technique resulting in stain deposit covering the blood film.
- control blood films not being used to demonstrate well prepared and correctly stained blood films and to reduce variability and subjectivity in blood film reporting.

*Note:* The preparation and staining of thin blood films are described in subunit 8.7. Equipment for purifying water in district laboratories is described in subunit 4.4 in Part 1 of the book.

- *Errors due to equipment being calibrated incorrectly or malfunctioning:* The performance of haemoglobinometers, water baths, and microscopes must be checked daily (see Chapter 4 in Part 1 of the book). To remain in working order, equipment must be used correctly, cleaned and serviced regularly. Problems associated with mains electricity supplies and the use of 12V batteries in district laboratories are discussed in subunit 4.2 in Part 1 of the book. The use of bench centrifuges is described in subunit 4.7 in Part 1 and haematocrit centrifuges in subunit 8.5.

*Note:* Quality control of the haematological tests included in this publication can be found in subsequent subunits describing the different tests.

### Post-analytical stage

Quality assurance in the post-analytical stage includes:

- Reporting and verifying haematological test results.
- Taking appropriate actions when a result has serious clinical implications.
- Ensuring test results are interpreted correctly and adequate records are kept.

### Reporting and verifying haematological tests

The terminology, units, and format used in reporting haematological tests should be standardized and agreed between laboratory staff and clinicians. Rubber stamps are useful for reporting differential white cell counts and red cell morphology. Errors in reporting the results of haematological tests mainly occur when reports are not checked by a senior member of staff for legibility, clarity, compatibility, and errors of calculation. Checked reports should be signed. Care must be taken to transfer correctly, test results from worksheets or report books to patients' forms.

When a test result is unexpected or seriously abnormal, the blood specimen should be checked e.g. for clots and when possible, the test repeated. A confirmed clinically serious report should be issued with the minimum of delay.

### Interpreting and recording haematological test results

Laboratory personnel should provide a reference range for the quantitative tests it performs and also understand the implications of test results. Where appropriate, experienced laboratory staff should provide useful interpretative comments. A record of the results of all investigations must be kept by the

laboratory, as carbon copies, work sheets, or in record books. Copies of work sheets should be dated and filed each day.

### External quality assessment

Whenever possible the Regional or Central Haematology laboratory should organize an external quality assessment (EQA) scheme to help district laboratories. It should not be too complicated, costly, or time-consuming. Safe stabilized control blood should be sent for measuring haemoglobin, performing a white cell count and differential, and other tests as required, e.g. to detect HbS. Stained control blood films for reporting should also be included to check that a laboratory is reporting correctly normal and abnormal appearances of red cells and white cells.

The main objective of an EQA scheme is to confirm that a laboratory's SOPs and internal QC procedures are working satisfactorily. EQA schemes help to identify errors, improve the quality of work, stimulate staff motivation, and assure users of the service that the laboratory is performing to the standard required to provide reliable results. The District Laboratory Coordinator should investigate and assist any poor performing laboratory and where indicated, arrange for further training of staff. Refresher courses should be held periodically to maintain competence in performing haematological tests and to introduce new technologies.

*Note:* Guidelines for starting a National EQA scheme in haematology can be found in the WHO publication, *Health laboratory services in support of primary health care in developing countries* (see Further information).

---

### FURTHER INFORMATION

**Lewis SM.** *Quality assurance in haematology*, WHO/LAB/98.4, 1998. Obtainable from Unit of Health Laboratory Technology (LAB/98.4), WHO, 1211 Geneva, 27-Switzerland (free of charge).

*Basics of quality assurance for intermediate and peripheral laboratories.* World Health Organization, Alexandria, 2nd edition, 2002. (WHO Regional Publication, Eastern Mediterranean Series No. 2). Obtainable from WHO Regional Office, Abdul Razzak Al Sanhoury Street, PO Box 7608, Nasr City, Cairo 11371, Egypt.

*Chapter 4, Quality Assurance in Haematology* in WHO publication, *Health laboratory services in support of primary health care in developing countries*. World Health Organization, New Delhi, 1994 (WHO Regional Publication SEARO, No. 24). Obtainable from WHO Regional Office, World Health House, Indraprastha Estate, New Delhi, 110002, India.

**Bates I.** Haematology in under-resourced laboratories. Ch. 26 in *Practical Haematology*, 9th edition, 2001, pp. 589–601. Churchill Livingstone, Elsevier Science.

## 8.2 Functions of blood, haematopoiesis, blood cell disorders

Blood is composed of a pale yellow fluid called plasma in which are suspended red cells (erythrocytes), white cells (leukocytes), and platelets (thrombocytes). Plasma forms about 55% of blood volume and contains water (95%) and many solutes, including proteins, mineral ions, organic molecules, hormones, enzymes, products of digestion, and waste products for excretion.

*Note:* Changes in the chemical constituents of blood occur in many diseases. Some of these are explained in Chapter 6 in Part 1 of the book which describes the important chemical substances found in blood and the biochemical tests used to measure their concentration in serum or plasma.

Blood flows through every organ of the body, providing effective communication between tissues. It is kept in continuous circulation by the pumping action of the heart, flowing through arteries which carry the oxygenated (bright red) blood from the heart to all parts of the body, and veins which carry the deoxygenated (dark red) blood from the different parts of the body back to the heart and to the lungs. The arteries divide into smaller vessels called capillaries forming the capillary, or peripheral, circulation which supplies oxygen to the tissues. The capillaries rejoin to form the veins. The same amount of blood that is pumped out of the heart returns to it. There are about 5–6 litres (approximately 10 pints) of blood in the circulatory system of an adult (7–8% of a person's body weight), and about 300 ml of blood in the system of a newborn infant.

### Main functions of the blood

Blood has important transport, distribution, regulatory, and protective functions in the body.

#### Transportation and distribution

- Oxygen is carried from the lungs to the tissues. This function is performed by haemoglobin which is present in large amounts in mature red cells.

- Nutrients absorbed from the digestive tract, e.g. monosaccharides (especially glucose), amino acids, fatty acids, glycerol, and vitamins, are transported to the cells of the body for use or storage.
- Waste products of metabolism are transported from the tissues to site of excretion, e.g. carbon dioxide produced from cellular activity is carried to the lungs for excretion, and the waste products of protein metabolism (urea, creatinine, uric acid) are transported to the kidneys for excretion.
- Hormones are carried from endocrine glands to the organs where they are needed.

#### Regulatory

- Buffer systems in the plasma maintain the pH of the blood between pH 7.35–7.45 and the pH in body tissues within the physiological limits required for normal cellular activity (see also subunit 6.10 in Part 1 of the book).
- Proteins (particularly albumin) and salts (particularly sodium chloride) regulate plasma osmotic pressure, preventing excessive loss of fluid from the blood into tissues spaces (see also subunits 6.10 and 6.11 in Part 1 of the book).
- Blood assists in regulating the temperature of the body by absorbing and distributing heat throughout the body and to the skin surface where heat which is not required is dissipated.

#### Protective

- When a blood vessel is damaged, platelets and blood coagulation factors interact to control blood loss. Platelets adhere to the damaged tissue and to one another and activated coagulation factors lead to the formation of fibrin and a thrombus clot which reinforce the platelet plug (explained more fully in subunit 8.11).
- Leukocytes are involved in the body's immune defences, producing antibodies in response to infection, and protecting the body from damage by viruses, bacteria, parasites, toxins and tumour cells.

### Blood cell production

The process by which blood cells are formed is called haematopoiesis, or haemopoiesis.

#### Haematopoiesis during foetal life and infancy

Blood cell production begins at 14–20 days in the foetal sac and this is the site of haematopoiesis for about 2 months. The liver and spleen become the main sites of blood cell production during the second trimester of pregnancy and foetal bone marrow in the third trimester. At birth, haematopoiesis is



confined to the bone marrow. During infancy and up to about 4 years of age, almost all the bones of the body contain blood cell producing red marrow.

#### *Haematopoiesis during adult life*

By about 25 years of age, the main sites of haematopoiesis are the vertebrae, ribs, sternum, skull bones, pelvis and sacrum, and the proximal ends of the femur and humerus. At these sites about half the marrow is red active cell producing marrow and the remainder, non-cell producing yellow fatty marrow. Other bone marrow cavities in the body contain non-haematopoietic fatty marrow. In certain blood disorders, e.g. chronic dyserythropoietic and haemolytic anaemias and myelofibrosis, blood cell production can resume in the liver and spleen (extramedullary haematopoiesis) and the fatty marrow in some bones can become replaced by haematopoietic marrow.

#### *Production of different blood cells*

Blood cells are renewed continuously. All blood cells originate from a common population of pluripotent stem cells in the bone marrow. The pluripotent stem cells proliferate and differentiate into two distinct cell lines: myeloid and lymphoid.

- *Myeloid stem cells:* These divide to form blood cell committed progenitor cells\* which differentiate through a series of cell divisions to form the various precursor cells which produce:

monocytes	basophils
neutrophils	red cells
eosinophils	platelets

\*Early progenitor cells are referred to as colony-forming units (CFU), e.g. CFU-E refers to the erythrocyte (E) progenitor cell, CFU-Meg to the platelet progenitor (Meg referring to the megakaryocyte cell from which platelets are formed), CFU-Eo to the eosinophil progenitor, CFU-Bas to the basophil progenitor, and CFU-GM refers to the common progenitor cell from which granulocytic (G) neutrophils and monocytes (M) develop.

*Note:* Only stem cells have the ability to self-replicate.

- *Lymphoid stem cells:* These divide to form lymphoid progenitor cells which differentiate into B & T lymphocytes. Early development of B lymphocytes takes place in the bone marrow and lymphoid tissues, and development of T lymphocytes in the thymus.

#### *Control of blood cell production*

Haematopoiesis is regulated by a range of cytokines (growth factors) which include interleukins, stem cell factors, colony stimulating factors, erythropoietin and thrombopoietin. They interact with specific receptors on the surface of haematopoietic cells, regulating the proliferation and differentiation of progenitor cells, and the maturation and functioning of mature cells.

## RED CELLS

Red cells (erythrocytes) form the main cellular component of blood, i.e. about 45% of total blood volume in an adult, giving blood its red colour. Each litre of blood contains about  $5 \times 10^{12}$  red cells, the exact number varying with age, gender, and state of health.

### Production of red cells

Red cells are produced in the bone marrow. Tissue hypoxia (lack of oxygen) leads to the release of the hormone erythropoietin which stimulates progenitor cells to develop into pronormoblasts (proerythroblasts).

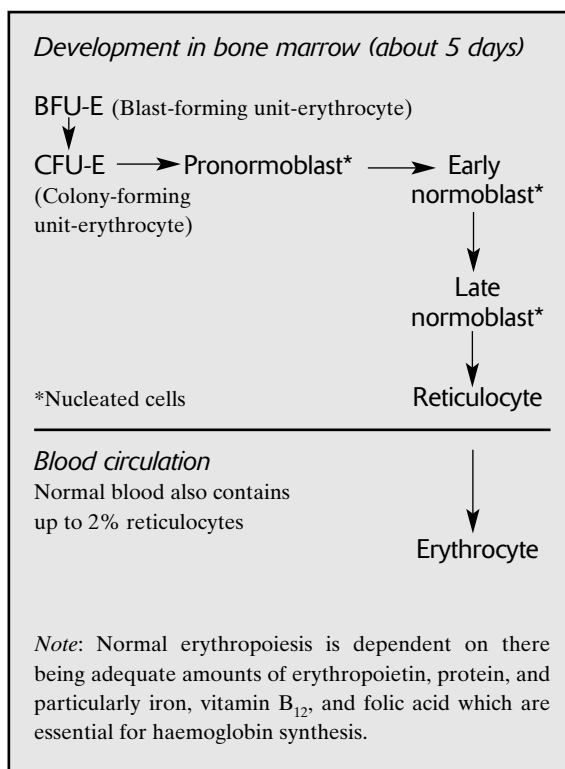

### Erythropoiesis

During erythropoiesis, the new cells formed following each cell division and maturation become smaller in size, their nucleus condenses, and haemoglobin (manufactured by ribosomes) begins to accumulate in the cytoplasm. With haemoglobinization the cytoplasm stains less blue and more pink-mauve. When the cells become about one third haemoglobinized, the nucleus is extruded and the cells collapse inwardly, forming biconcave discs. At the reticulocyte stage, the cells have no nucleus and stain pale mauve. They contain large amounts of haemoglobin and only remnants of ribosomal RNA and endoplasmic reticulum. Reticulocytes enter the blood circulation and within 48 h, develop into fully haemoglobinized pink-red staining erythrocytes.

### Erythrocyte

A mature red cell measures about 8  $\mu\text{m}$  in diameter. It is mainly composed of haemoglobin surrounded by a flexible protein membrane and outer lipid bilayer. The biconcave form of the red cell and membrane which is made of specialized deformable protein fibres, enable the cell to pass through capillaries of small diameter. Its shape also provides a large surface area for the exchange of respiratory gases.

Energy required for the maintenance of red cell shape, flexibility, and osmotic pressure is provided by ATP (adenosine triphosphate) generated by anaerobic glycolysis (Embden-Meyerhof pathway). Other red cell metabolic systems such as the hexose monophosphate pathway, are involved in the detoxification of oxidants to prevent oxidative damage to haemoglobin and other cell constituents.

### Haemoglobin

Each molecule of haemoglobin contains four linked polypeptide (globin) chains which in an adult consist of two *alpha* ( $\alpha$ ) chains containing 141 amino acids and two *beta* ( $\beta$ ) chains containing 146 amino acids\*.

\*96–98% of normal adult haemoglobin is HbA, having 2 *alpha* chains and 2 *beta* chains ( $\alpha\alpha/\beta\beta$ ). Up to 3.5% is HbA<sub>2</sub> consisting of 2 *alpha* chains and 2 *delta* chains ( $\alpha\alpha/\delta\delta$ ). Less than 1% is HbF (fetal) composed of 2 *alpha* chains and 2 *gamma* chains ( $\alpha\alpha/\gamma\gamma$ ). HbF is the predominant haemoglobin in a fetus and for the first 3–6 months of life.

Each polypeptide chain is combined with an iron-containing porphyrin pigment called haem which is the oxygen carrying part of the haemoglobin molecule. Oxygen binds reversibly to the ferrous ion ( $\text{Fe}^{2+}$ ) contained in each haem group.

Haemoglobin takes up oxygen when the partial pressure of oxygen ( $PO_2$ ) in the blood is high and releases it when the  $PO_2$  is low. When the blood is in the lungs therefore, it rapidly combines with haemoglobin, forming oxyhaemoglobin. The blood becomes about 97% saturated with oxygen (every gram of haemoglobin combining with 1.34 ml of oxygen). When the blood passes through the tissues where the  $PO_2$  is low, oxygen dissociates from the haemoglobin. Under resting conditions the blood normally loses about 30% of its oxygen content in the tissues.

**Oxygen dissociation:** Oxygenation and deoxygenation of haemoglobin involve interactions between the globin chains and the red cell metabolite, 2,3-diphosphoglycerate (2,3-DPG). As oxygen is bound, the chains move close together. As oxygen is released, the two  $\beta$  chains move apart slightly, allowing the entry and binding of 2,3-DPG. This lowers oxygen affinity, facilitating the release of oxygen from the haemoglobin. The affinity of haemoglobin for oxygen also varies with temperature and the concentration of  $\text{H}^+$  ions (pH) and  $\text{CO}_2$  ( $PCO_2$ ). An increase in temperature (e.g. following exercise), a fall in pH, or a rise in  $PCO_2$ , decrease oxygen affinity, increasing oxygen delivery to tissues.

About 20% of carbon dioxide ( $\text{CO}_2$ ) is transported by the red cells from the tissues to the lungs for

excretion.  $\text{CO}_2$  binds to the globin part of haemoglobin forming carbaminohaemoglobin. Most  $\text{CO}_2$  is transported as bicarbonate ions in the plasma.

### Normal breakdown of red cells

At the end of their life-span of about 120 days, degenerate red cells are removed from the circulation by reticuloendothelial cells, mainly in the spleen. The haem is split from the globin. Most of the globin is hydrolyzed and the constituents returned to the amino acid pool. The iron component is either reused to produce new red cells or stored in the reticuloendothelial cells as ferritin or haemosiderin.

The remaining porphyrin of the haem is metabolized to bilirubin which binds to albumin in the plasma. In the liver, the bilirubin is conjugated to glucuronic acid, forming water soluble conjugated bilirubin which passes into the intestine. It is metabolized to urobilinogen and mostly excreted as stercobilin and stercobilinogen in the faeces. Some of the urobilinogen is reabsorbed from the intestine and excreted in the urine as urobilin and urobilinogen.

**Intravascular lysis:** Haemoglobin from red cells which become destroyed in the circulation (intravascular lysis) becomes complexed to haptoglobin and removed by the liver. In health a small number of red cells break up in the circulation. The released haemoglobin is complexed with haptoglobin. In intravascular haemolysis, the haptoglobin capacity is exceeded, resulting in free haemoglobin circulating.

### Disorders of red cells

The main disorders of red cells are:

- Anaemia
- Haemoglobinopathies (thalassaemias, abnormal haemoglobins)
- Disorders due to red cell enzyme defects, e.g. G6PD deficiency
- Disorders due to red cell membrane defects, e.g. hereditary spherocytosis
- Polycythaemia

### ANAEMIA

Worldwide anaemia is the commonest red cell disorder. It occurs when the concentration of haemoglobin falls below what is normal for a person's age, gender, and environment, resulting in the oxygen-carrying capacity of the blood being reduced.

Haemoglobin values are lower in women than men, probably due to menstrual loss and the influence of hormones on erythropoiesis. Haemoglobin levels fall in normal pregnancy due to an increase in plasma volume.

**Normal lower limits for haemoglobin\***

Anaemia is present when the haemoglobin concentration falls below:

Newborn infants	140 g/l (14.0 g/dl)
Child 6 months–4 years	110 g/l (11.0 g/dl)
Child 5–11 years	115 g/l (11.5 g/dl)
Child 12–14 years	120 g/l (12.0 g/dl)
Non-pregnant women	120 g/l (12.0 g/dl)
Pregnant women	110 g/l (11.0 g/dl)
Men and adolescent boys	130 g/l (13.0 g/dl)

\*Values are for those living at sea level. Haemoglobin levels rise with altitude, e.g. by about 10 g/l at 2000 m (6500 feet) and about 20 g/l at 3000 m (10 000 feet).

Anaemia is described as *mild* when the haemoglobin is between 100 g/l and the level in the above table, *moderate* when 70–100 g/l, and *severe* when below 70 g/l.

*Note:* Figures are taken from WHO publications *Iron deficiency: Indicators for assessment and strategies for prevention* (WHO NUT/96.12, 1996), and *Preventing and controlling iron deficiency anaemia through primary health care* (WHO, 1989).

Anaemia can develop:

- following blood loss,
- when the normal production of red cells is reduced,
- when red cells are destroyed (haemolyzed) prematurely.

Often these mechanisms overlap with several factors contributing to a person becoming anaemic. Anaemia due to haemorrhage or acute haemolysis causes more serious symptoms than anaemia of slow onset, e.g. iron deficiency caused by chronic blood loss. Low haemoglobin levels may cause few symptoms in anaemias associated with increased levels of 2,3-DPG in red cells, e.g. sickle cell anaemia. Haemoglobin values may be high in patients with burns and severe dehydration due to changes in plasma volume, and when there is acute blood loss with no compensation.

**Anaemia in tropical countries**

In tropical and developing countries anaemia is particularly prevalent with 50% or more of pre-school children and pregnant women being moderately or severely anaemic.

**Symptoms and features of anaemia**

Anaemic persons are easily fatigued, have little energy to work, are often breathless on exertion, have palpitations and

experience headaches and dizziness. There is pallor of the skin, mucous membranes and conjunctiva. Young children with moderate and severe anaemia are slow to develop physically and mentally, have difficulty in concentrating and learning, and are more prone to infection with poor immune responses. Pregnant women with untreated anaemia are at increased risk of dying during or following childbirth (particularly when complicated), or giving birth prematurely or to an infant with low birthweight. There is also an increased risk of puerperal infection.

The main causes (often interacting) of anaemia in tropical countries are:

- Malnutrition, associated particularly with:
  - Iron deficiency anaemia. *Iron deficiency is the commonest form of anaemia and a major health problem in tropical countries.*
  - Folate deficiency (less commonly, vitamin B<sub>12</sub> deficiency)
  - Protein deficiency
- Parasitic, bacterial, and viral infections, particularly:
  - Falciparum malaria, hyperreactive malaria, splenomegaly (see subunit 5.7 in Part 1 of the book, *Malaria is the commonest cause of death from anaemia in young children in tropical countries.*
  - Hookworm infection (see subunit 5.5 in Part 1)
  - Tuberculosis and other chronic infections (see later text)
  - HIV disease/AIDS and treatment with antiretroviral drugs such as zidovudine (see subunit 7.18.55)
  - Visceral leishmaniasis (see subunit 5.10 in Part 1)
  - African trypanosomiasis (see subunit 5.8 in Part 1)
  - Less commonly, parvovirus B19 infection (see later text) and viral haemorrhagic fever diseases (see subunit 7.2)
- Inherited haemoglobinopathies, including:
  - Sickle cell disease (see later text)
  - Thalassemia syndromes (see later text)
- Glucose 6 phosphate dehydrogenase (G6PD) deficiency (see later text).
- Obstetrical complications causing abnormal blood loss.

**Iron deficiency anaemia**

Iron is needed to produce the haem component of haemoglobin and a small amount is needed to produce muscle myoglobin and cytochromes (respiratory enzymes). Insufficient iron for haemoglobin production leads to iron deficiency anaemia.

*Causes of iron deficiency*

- Intake of iron is insufficient or the iron in the diet is in a form which is not easily absorbed, e.g. non-haem iron of plant origin (in contrast, haem iron in meat is easily absorbed). Also, diets in tropical countries are often high in substances which inhibit the absorption of non-haem iron e.g. phytic acid in grain fibres. Ascorbic acid in the diet helps to absorb non-haem iron.
- Increased loss of iron due to chronic blood loss as occurs in severe hookworm infection, schistosomiasis, trichuriasis, gastrointestinal bleeding, menorrhagia.
- Malabsorption of iron as in intestinal malabsorptive disease, e.g. acute post-infective malabsorption (PIM).
- Increased demand for iron as occurs in the early years of life and during pregnancy.

*Note:* Iron deficiency causes a *microcytic hypochromic anaemia* (see later text).

**Folate deficiency and vitamin B<sub>12</sub> deficiency**

Folate (folic acid) and vitamin B<sub>12</sub> (cobalamins) are essential for DNA (deoxyribonucleic acid) synthesis and are therefore needed by all dividing cells in the body, particularly haematopoietic cells in the bone marrow. Deficiencies lead to nuclear maturation being blocked which prevents growing cells from dividing normally (cytoplasmic maturation is not blocked). Many precursor cells die in the bone marrow. Vitamin B<sub>12</sub> is also needed to prevent degenerative changes in the nervous system.

*Causes of folate deficiency*

- Low intake of folate in the diet (often seasonal) or more commonly, folate is inadequate because it is destroyed when food is overheated e.g. prolonged boiling of folate rich foods such as green vegetables, sweet potatoes, yams, plantain, peppers, meat, fish.
- Intestinal malabsorptive disease, e.g. PIM and malabsorption associated with *Giardia lamblia* and *Strongyloides* infections. Folate absorption is also depressed in diseases such as tuberculosis and severe pneumonia.
- High demands for folate in infancy (particularly premature infants) and childhood, during pregnancy, and in diseases such as sickle cell disease, malaria and other haemolytic anaemias. Also in malignant disease.
- Drugs which interfere with folate utilization, e.g. pyrimethamine, trimethoprim and antifolate cytotoxic drugs.

*Causes of vitamin B<sub>12</sub> deficiency*

Deficiency due to low intake is rare. Vitamin B<sub>12</sub> is synthesized by bacteria and is therefore available in foods of animal origin. The body's daily requirement for vitamin B<sub>12</sub> is low. Intrinsic factor (IF), a protein secreted by parietal cells in the stomach, is essential for the absorption of vitamin B<sub>12</sub>. The main causes of vitamin B<sub>12</sub> deficiency are:

- Lack of IF due to gastric disease such as autoimmune gastritis (pernicious anaemia) which damages parietal cells and prevents IF secretion.
- Intestinal malabsorption due to PIM, chronic *Giardia lamblia* infection and severe enteritis.
- Rare causes include cyanide poisoning from the incorrect preparation of cassava, and infection with the fish tapeworm *Diphyllobothrium latum* (competes with host for vitamin B<sub>12</sub>).

*Note:* Folate and vitamin B<sub>12</sub> deficiencies cause *megaloblastic*

*changes in the bone marrow with a macrocytic anaemia and in the advanced stage, pancytopenia* (low numbers of red cells, granulocytes, and platelets), see later text.

**Chart 8.2 Mechanisms of anaemia****BLOOD LOSS**

- Acute bleeding, e.g. from wounds, surgical, ectopic pregnancy, placenta praevia
- Chronic blood loss, e.g. hookworm infection, schistosomiasis, gastrointestinal bleeding, menorrhagia

**DECREASED RED CELL PRODUCTION**

- Lack of essential nutrients, e.g. deficiencies of iron, folate, vitamin B<sub>12</sub>, protein
- Depressed bone marrow activity, e.g. anaemias associated with chronic disease such as tuberculosis, HIV disease, chronic nephritis, chronic hepatitis, connective tissue disorders, malignant disease, leukaemias
- Due to drugs, chemicals, ionizing radiation, some viruses
- Thalassaemia syndromes

**INCREASED RED CELL DESTRUCTION (HAEMOLYSIS)**

- Inherited haemolytic anaemias:
  - Haemoglobinopathies, e.g. sickle cell diseases, thalassaemia syndromes
  - Red cell enzyme deficiencies, e.g. G6PD deficiency, pyruvate kinase deficiency
  - Red cell membrane defects e.g. hereditary spherocytosis
- Non-immune acquired haemolytic anaemias:
  - Infections, e.g. malaria, African trypanosomiasis, meningococcal septicaemia, *C. perfringens* infection, bartonellosis
  - Pre-eclampsia and HELLP syndrome (haemolysis, elevated liver enzymes, low platelet count)
  - Conditions which cause disseminated intravascular coagulation (DIC)
  - Haemolytic uraemic syndrome
  - Hypersplenism and splenomegaly, e.g. visceral leishmaniasis, hyper-reactive malaria, splenomegaly, myelofibrosis
  - Burns
  - Venomous snake and spider bites
  - Chemicals, oxidant drugs, local herbal remedies
  - Paroxysmal nocturnal haemoglobinuria
- Immune acquired haemolytic anaemias (DAT positive):
  - Haemolytic disease of the newborn
  - Haemolytic blood transfusion reaction
  - Warm reactive autoantibody, e.g. drug-induced chronic lymphatic leukaemia, lymphoma, systemic lupus erythematosus
  - Cold reactive autoantibody, e.g. *M. pneumonia* infection, lymphoma
  - Paroxysmal cold haemoglobinuria

**Anaemias of infections and chronic disease**

The following diseases are associated with anaemia:

- *Infectious diseases*
  - Tuberculosis
  - Pneumonia
  - Pulmonary abscess
  - Bacterial endocarditis
  - Pelvic inflammatory disease
  - Osteomyelitis
  - HIV disease
- *Non-infectious diseases*
  - Malignant disease
  - Systemic lupus erythematosus
  - Rheumatoid arthritis
  - Other connective tissue disorders

*Note:* Most chronic diseases cause a moderate *normocytic normochromic anaemia*, becoming microcytic, hypochromic and often more severe as disease progresses (see later text).

**Anaemia associated with parvovirus B<sub>19</sub> infection**

In tropical countries most infections with parvovirus B<sub>19</sub> occur early in life and do not cause serious symptoms. Acute parvovirus B<sub>19</sub> infections can however cause severe life-threatening anaemia in pregnant women and in those with pre-existing haemolytic anaemia, e.g. sickle cell disease, thalassaemia, falciparum malaria. The virus infects erythroid progenitor cells in the bone marrow, reducing red cell production (aplastic crisis). In patients with HIV disease, viraemia often persists, causing chronic reduced erythropoiesis. Parvovirus B<sub>19</sub> can be transmitted by droplet infection, infected blood, and transplacentally. Fetal infection can cause severe anaemia, leading to abortion or stillbirth.

**Laboratory investigation of anaemia**

A knowledge of a patient's symptoms and clinical history can often establish the cause(s) of anaemia. Investigation is needed when there is moderate or severe anaemia and the reason for it is not apparent. Laboratory tests can help to identify the type of anaemia and monitor a patient's response during treatment.

Morphologically anaemia can be classified by:

- Red cell size with the terms:
  - *Normocytic* referring to normal size red cells (approximately 8 µm in diameter),
  - *Microcytic* referring to smaller than normal red cells,
  - *Macrocytic* referring to larger than normal red cells.

*Note:* With experience, significant microcytosis and macrocytosis can be detected (with associated abnormalities) by examining a well made Romanowsky stained thin blood film. Normal size red cells are the same size or slightly smaller than a small lymphocyte.

**MCV (Mean Cell Volume):** Information on red cell size can be determined from the MCV, expressed in femtolitres (fl),

see subunit 8.5. When the red cells are macrocytic, the MCV is increased and when the cells are microcytic, the MCV is reduced.

- Haemoglobinization of red cells with the terms:
  - *Normochromic*, describing normal staining of red cells as seen when haemoglobinization is adequate. The cells contain a small area of central pallor (no more than one third of the cell's diameter) due to the biconcavity of red cells.
  - *Hypochromic*, describing pale staining of red cells, as seen when haemoglobinization is inadequate. Hypochromic cells show an increased area of central pallor.

*Note:* Significant hypochromia can be detected in a well made Romanowsky stained thin blood film.

**MCH (Mean cell haemoglobin):** The amount of haemoglobin in picograms (pg) in an average red cell can be calculated as described in subunit 8.5. When red cells are hypochromic, the MCH is reduced and when the cells are macrocytic, the MCH is increased.

**MCHC (Mean cell haemoglobin concentration):** The concentration of haemoglobin in g/l in 1 litre of packed red cells can be calculated as described in subunit 8.5. When red cells are hypochromic and microcytic, the MCHC is reduced.

*Polychromatic red cells (reticulocytes):* These immature cells contain residual RNA and ribosomes. They can be differentiated from mature red cells in Romanowsky stained blood films by their blue-grey colour (polychromasia) and larger size. Increased numbers of reticulocytes in the peripheral blood (reticulocytosis) can be found in anaemia due to red cell destruction when there is effective erythropoiesis, e.g. most haemolytic anaemias, recovery from acute haemorrhage, and response to treatment of anaemia. Reticulocytosis is not a feature of anaemia due to impaired red cell production, e.g. iron deficiency anaemia, and megaloblastic anaemia unless treatment has been given.

**MICROCYTIC HYPOCHROMIC ANAEMIA**

Caused by:

- Iron deficiency (commonest cause)
- Thalassaemia syndromes (see later text)
- Some anaemias of chronic disease
- Sideroblastic anaemia\*

\* Rare hereditary disorder or acquired disorder in which iron accumulates in the mitochondria of the erythroblast and is not incorporated into the haem. It can be found in association with myelodysplastic syndrome and myeloproliferative disease. It can also be caused by drugs (e.g. isoniazid, chloramphenicol), alcoholism and lead poisoning.

*Investigation in district laboratories*

- Blood film findings:
  - Microcytic hypochromic red cells
  - Poikilocytosis with elongated ('pencil') cells, typically seen in iron deficiency anaemia
  - Target cells, found particularly in thalassaemia syndromes
  - Report also any abnormalities of leukocytes

*Note:* In sideroblastic anaemia, a dimorphic blood picture may be seen, i.e. normocytic normochromic red cells with microcytic hypochromic cells.

- Red cell indices in microcytic hypochromic anaemia:
  - MCHC: ↓ below 310 g/l. In thalassaemia trait, MCHC may be normal.
  - MCV: ↓ below 76 fl. Particularly low in thalassaemia, even when anaemia is mild.
  - MCH: ↓ below 27 pg.

*Note:* In addition to the above haematological tests, faeces should also be examined for hookworm eggs and occult blood. Chronic blood loss from hookworm infection is a common cause of iron deficiency anaemia in tropical countries.

---

**Other tests to investigate microcytic hypochromic anaemia**  
 (Requiring the facilities of a specialist laboratory)

Tests	Iron deficiency	Thalassaemia trait	Sideroblastic anaemia	Chronic disease
● Serum ferritin <sup>1</sup>	↓	N	↑	N/↑
● Serum iron	↓	N/↑	↑	↓
● TIBC	↑	N/↓	N/↓	↓
● Bone marrow iron	–	+	+ <sup>2</sup>	+
● Haemoglobin electrophoresis	N	↑HbA <sub>2</sub> (β form)	N	N

*Notes*

- 1 Sensitive early indicator of iron deficiency
- 2 Ringed sideroblasts present (iron granules form a ring around nucleus of erythroblasts)

N = Normal, TIBC = Total iron binding capacity, ↑ = Increased, ↓ = Reduced

---

**MACROCYTIC ANAEMIA**

Caused by:

Megaloblastic changes:

- Folate deficiency
- Vitamin B<sub>12</sub> deficiency

Non-megaloblastic changes:

- Liver disease
- Alcoholism
- Haemolytic anaemia (associated with raised reticulocyte count, see later text)

*Investigation in district laboratories*

- Blood film findings:
  - Macrocytic red cells. In folate/B<sub>12</sub> deficiency, macrocytes are typically oval in shape. In liver disease and alcoholism, macrocytes are mostly round.
  - Poikilocytosis, often with tear drop cells. In severe liver failure, acanthocytes may be seen. With alcoholism, stomatocytes may be seen.
  - Anisocytosis
  - Occasionally, megaloblasts, basophilic stippling and Howell Jolly bodies are seen.
  - Target cells are typically seen in liver disease.
  - Pancytopenia is common in advanced megaloblastic anaemia with low numbers of red cells, leukocytes, and platelets.
  - Hypersegmentation of neutrophils (>5% with 5 lobes or more) in megaloblastic anaemia.

*Note:* Hypersegmentation of neutrophils is not seen in macrocytic anaemia due to liver disease or alcoholism.

- Reticulocytes: Normal or low.
- Red cell indices in macrocytic anaemia:
  - MCHC: Normal (315–360 g/l).
  - MCV: ↑, more than 100 fl.
  - MCH: ↑, more than 32 pg.

---

**Other tests to investigate macrocytic anaemia**  
 (Requiring the facilities of a specialist laboratory)

Tests	B <sub>12</sub> deficiency	Folate deficiency
● Serum B <sub>12</sub> (Normal value, 160–925 ng/l)	↓	N
● Red cell folate (Normal value, 160–640 µg/l)	N/↓	↓
● Serum folate (Normal value, 3.0–15.0 µg/l)	N/↑	↓
● Bone marrow: Megaloblastic and hypercellular often with giant metamyelocytes		
● Serum unconjugated bilirubin: ↑ due to destruction of cells in marrow and ineffective erythropoiesis.		

*Note:* Red cell folate is more likely to accurately reflect tissue deficiency than serum folate. Occasionally other tests may also be required to assess gastric function and to test for antibodies to gastric parietal cells.

---

**NORMOCHROMIC ANAEMIA**

In a normocytic normochromic anaemia the red cells appear normocytic and normochromic in a stained blood film and the MCHC; MCV and MCH are normal.

A normocytic normochromic anaemia may be found in:

- Acute blood loss
- Anaemia of chronic disease
- Aplastic anaemia

#### Anaemia of chronic disease

Infections, malignancies, and chronic inflammatory conditions (see previous text), can cause normocytic normochromic or microcytic hypochromic anaemia. Examination of a blood film for RBC and leukocyte abnormalities is helpful, particularly in identifying anaemia due to infection. Other tests to perform will depend on the clinical findings.

#### Aplastic anaemia

In aplastic anaemia there is a reduction in the number of red cells, neutrophils, and platelets in the peripheral blood (pancytopenia), low reticulocyte count, and decrease in blood-forming tissue in the bone marrow. Causes of acquired aplastic anaemia include drugs (e.g. chloramphenicol, non-steroidal anti-inflammatory drugs, cytotoxic drugs), viral infection (e.g. hepatitis viruses, Epstein-Barr virus) and ionizing radiation.

*Note:* Other causes of pancytopenia include HIV disease, visceral leishmaniasis, leukaemia, multiple myeloma, myelofibrosis, megaloblastic anaemia, myelodysplastic disorders, parvovirus, and splenomegaly.

#### Haemolytic anaemias

Haemolytic anaemias are characterized by a falling haemoglobin, jaundice, dark urine, increasing reticulocytosis (when there is effective erythropoiesis) and usually splenomegaly. In tropical countries haemolytic anaemias due to both intrinsic causes (hereditary disorders) and extrinsic causes (acquired disorders) are important causes of ill health and premature death, particularly those due to serious thalassaemia syndromes, diseases due to abnormal haemoglobins, and haemolysis associated with malaria, other parasitic infections, and bacterial infections.

*Extravascular haemolysis:* In most haemolytic anaemias, haemolysis is extravascular, i.e. red cells are destroyed by macrophages in the spleen, liver, and bone marrow. Provided liver function is normal there is an increase in serum unconjugated bilirubin and urine urobilinogen (urine bilirubin is negative).

*Intravascular haemolysis:* This is when red cells are destroyed in blood vessels and haemoglobin is released into the circulation e.g. haemolysis following incompatible blood transfusion, malaria haemoglobinuria, paroxysmal nocturnal haemoglobinuria (rare complement-mediated haemolysis), or when there is red cell membrane damage due to antibody and complement, toxic chemicals or drugs. Laboratory findings in intravascular haemolysis include reduced or absent serum haptoglobins, haemoglobinaemia (free haemoglobin in the plasma), presence of methaemalbumin in plasma, and haemoglobin and haemosiderin in urine.

#### Investigation of haemolytic anaemia in district laboratories

In haemolytic anaemia, the serum/plasma appears

yellow due to increased bilirubin. A clinical history and examination of a blood film can help to establish the possible cause of a haemolytic anaemia and indicate the need for further tests to confirm the diagnosis and assist in treatment and genetic counselling (when a hereditary condition is suspected). Laboratory staff should be aware of the local distribution of hereditary disorders, e.g. haemoglobinopathies and the common causes of acquired haemolytic anaemias (see previous Chart 8.2).

#### ● Blood film findings:

- Red cells are usually normochromic. Microcytic hypochromic cells are found in thalassaemia (see Chart 8.3) and when there is accompanying iron deficiency anaemia.
  - Polychromasia (indicating reticulocytosis) is present in most haemolytic anaemias when there is an effective erythropoietic response. In malaria\*, reticulocytes are only slightly increased in the early stages of infection.
- \*Anaemia in malaria is multifactorial. It includes bone marrow suppression in addition to haemolysis.
- Sickle cells which are typically seen in sickle cell anaemia, HbSC disease, HbS thalassaemia (see later text).
  - Malaria parasites in red cells, often with malaria pigment in leukocytes (see p. 252 in Part 1 of the book).
  - Trypanosomes in blood film (see p. 262 in Part 1). Acute African trypanosomiasis is a cause of rapidly progressive haemolytic anaemia.
  - Spherocytes which may be seen in *C. perfringens* septicaemia, serious burns, bartonellosis, in G6PD deficiency (during haemolytic crisis), acquired immune haemolytic anaemia due to warm reactive autoantibody, ABO haemolytic disease of the newborn, in haemolytic uraemic syndrome (rare) and typically in hereditary spherocytosis (inherited red cell membrane disorder).
  - Nucleated red cells, which can be seen in sickle cell disease,  $\beta$  thalassaemia major and intermedia disease (see Chart 8.3), *C. perfringens* septicaemia, haemolytic disease of the newborn, and autoimmune haemolytic anaemias (due to warm reacting antibody).
  - Red cell fragments (schistocytes) which are seen when red cells are damaged, e.g. in burns, disseminated intravascular coagulation, pre-eclampsia, and in microangiopathic

anaemia associated with Gram negative septicaemia and less commonly, artificial heart valves.

- ‘Bite’ and ghost cells which can be seen during a haemolytic crisis caused by G6PD deficiency (Heinz bodies may also be seen in a reticulocyte preparation, see subunit 8.9).
- Target cells which are seen particularly in thalassaemia syndromes (see Chart 8.3), sickle cell disease, HbC disease, liver disease.
- Basophilic stippling, which is most frequently seen in thalassaemia syndromes (see Chart 8.3).
- Marked red cell agglutination (clumping due to antibody-coating) of red cells which is seen in immune haemolytic anaemia due to cold reacting autoantibody (unless blood sample is kept at 37 °C).
- *Bartonella* organisms in red cells, causing Oroya fever (see subunit 7.18.36).

- Detection of cold agglutinins\*
- Tests to detect intravascular haemolysis:
  - Haemoglobin in urine, see pp. 381–382, in Part 1
  - Haemosiderin in urine\*
  - Schumms test (methaemalbumin)\*
  - Haemoglobin in plasma\*
  - Serum haptoglobins\*
- Test to detect RBC membrane defects:
  - Autohaemolysis test\*
  - Osmotic fragility\*
  - Glycerol lysis test\*
  - Ham’s test\*

If cold agglutinin disease is suspected

To investigate intravascular haemolysis, e.g. malaria haemoglobinuria, haemolytic blood transfusion reaction, antibody or drug induced intravascular haemolysis

If red cell membrane disorder is suspected, e.g. hereditary spherocytosis, paroxysmal nocturnal haemoglobinuria

\*Details of these and other tests to investigate haemolytic anaemias can be found in *Practical Haematology*, Churchill Livingstone, 9th edition, 2001, and other practical haematology textbooks.

#### Other tests to investigate haemolytic anaemia

Tests	Indication
● Reticulocyte count, see subunit 8.9	To assess erythropoietic activity
● Sickle cell slide test or solubility test, see subunit 8.10	If sickle cell disease is suspected clinically or from a blood film
● Haemoglobin electrophoresis, see subunit 8.10	To demonstrate HbS, HbC or other abnormal haemoglobin. To detect raised HbA <sub>2</sub> and HbF if thalassaemia syndrome is suspected (see Chart 8.3).
● G6PD screening test, see end of subunit 8.9	If G6PD deficiency is suspected (see later text).
● Direct antiglobulin test (DAT) using broad spectrum serum, see subunit 9.4	If immune haemolytic anaemia is suspected. <i>Positive DAT is found with:</i> <ul style="list-style-type: none"> <li>– Warm reacting autoantibody (IgG, complement)</li> <li>– Cold reacting autoantibody (IgM)</li> <li>– Drug induced autoantibody, e.g. methyl dopa, penicillin, cephalothin quinidine, chloramphenicol</li> <li>– Haemolytic disease of the newborn</li> <li>– Incompatible haemolytic blood transfusion reaction</li> </ul> <i>Note:</i> Positive DAT is often found during or after malarial parasitaemia. It is usually of no significance

#### THALASSAEMIA SYNDROMES

Thalassaemia syndromes are inherited disorders caused by a reduction in the rate of synthesis of *alpha* ( $\alpha$ ) or *beta* ( $\beta$ ) haemoglobin chains.\*

\*The symbol ° indicates total suppression of globin chain production and + indicates partial suppression.

- *Alpha* thalassaemias are caused by defective synthesis of  $\alpha$  chains.
- *Beta* thalassaemias are caused by defective synthesis of  $\beta$  chains.

Significant imbalance in the synthesis of  $\alpha$  and  $\beta$  chains leads to:

- Inadequate haemoglobin production. The MCV and MCH are low and the red cells appear *microcytic* and *hypochromic*.
- Accumulation of free uncombined globin chains in normoblasts and red cells, causing the destruction of red cell precursors in the bone marrow (ineffective erythropoiesis) and red cell destruction by the spleen.

The clinical severity of  $\alpha$  and  $\beta$  thalassaemia syndromes depends on the thalassaemia genes inherited, and in some syndromes, the interaction of thalassaemia genes with abnormal haemoglobin genes, e.g. HbS, HbE, HbC. The terms thalassaemia major, intermedia, and minor are used to describe the severity of disease.



### Alpha thalassaemias

A person normally inherits four genes ( $\alpha\alpha/\alpha\alpha$ ) for the production of *alpha* ( $\alpha$ ) globin chains. Deletion of one or more genes is the commonest cause of  $\alpha$  thalassaemias. Less commonly,  $\alpha$  gene inactivity can result from gene mutations. Clinically important  $\alpha$  thalassaemia syndromes include:

- HbH ( $\beta_4$ Hb) disease which is usually caused by the genotype  $-/-\alpha$  (doubly heterozygous  $\alpha^\circ$  thalassaemia/ $\alpha^+$  thalassaemia). Three of the four  $\alpha$  genes are inactive.

**HbH** is formed from unstable tetramers of uncombined  $\beta$  chains ( $\beta_4$ ).

HbH disease is mainly found in Southeast Asia where high gene frequencies for both  $\alpha^+$  and  $\alpha^\circ$  thalassaemia exist. HbH disease can also be caused by gene mutations, e.g.  $\alpha^\circ$  thalassaemia/Hb Constant Spring\* (also found in Southeast Asia) or homozygous non-deletional  $\alpha$  gene mutations (found in Saudi Arabia).

\***Hb Constant Spring**: Formed from abnormal elongated  $\alpha$  chains combining with  $\beta$  chains

*Laboratory features*: In HbH disease, the unstable HbH is precipitated as intracellular inclusion bodies causing haemolysis with anaemia which may become severe during infection, pregnancy, and following treatment with oxidant drugs. The MCV and MCH are reduced. Red cells appear microcytic and hypochromic. There is a reticulocytosis. More than 30% of red cells will contain HbH inclusion bodies (precipitated  $\beta$  chain tetramers).

- Fatal Hb Bart's hydrops syndrome ( $\alpha$  thalassaemia major) in which there is a homozygous inheritance of  $\alpha^\circ$  thalassaemia, genotype  $-/-$  - from parents with  $\alpha^\circ$  thalassaemia trait. There is deletion of all four  $\alpha$  genes, resulting in no  $\alpha$  globin chains being synthesized and therefore no production of HbF, HbA, or HbA<sub>2</sub>. The fetus produces Hb Barts (>80%)\* and small amounts of HbH. The infant is either stillborn prematurely or dies soon after birth.

\***Hb Barts**: It is formed from tetramers of the  $\gamma_4$ -chain. Causes hypoxia because it has a high oxygen affinity.

Mothers of infants with Hb Barts hydrops syndrome often develop pre-eclamptic toxemia. The condition is mainly found in Southeast Asia.

#### Asymptomatic $\alpha$ thalassaemia syndrome

- $\alpha^+$  thalassaemia trait in which there is a single gene deletion (genotype  $-\alpha/\alpha$ ). Heterozygous  $\alpha^+$  thalassaemia is an asymptomatic condition.

- $\alpha^\circ$  thalassaemia trait in which two genes are deleted (genotypes  $-\alpha/-\alpha$  or  $-/-\alpha\alpha$ ). A person with homozygous  $\alpha^+$  thalassaemia ( $-\alpha/-\alpha$ ) or heterozygous  $\alpha^\circ$  thalassaemia ( $-/-\alpha\alpha$ ) usually has a mild microcytic anaemia. Serum iron and serum ferritin levels are normal.

*Note*:  $\alpha^+$  gene deletions ( $-\alpha/\alpha$ ) causing asymptomatic  $\alpha^+$  thalassaemia trait are common in sub-Saharan Africa, India, Nepal, Papua New Guinea and Pacific Islands. Heterozygous  $\alpha^\circ$  thalassaemia ( $-/-\alpha\alpha$ ) is prevalent in Southeast Asia and Southern China.

### Beta Thalassaemias

A person normally has two genes ( $\beta/\beta$ ) for the production of *beta* ( $\beta$ ) globin chains. Gene mutations are the commonest causes of  $\beta$  thalassaemias. Less commonly gene deletions are involved. Geographically, thalassaemic genes can be found in the Mediterranean region, Middle East, India, Pakistan, Southeast Asia, Indonesia, Pacific islands and parts of north and west Africa. Clinically important  $\beta$  thalassaemia syndromes include:

- $\beta$  Thalassaemia major which is caused by the following genotypes:

$\beta^\circ/\beta^\circ$ , i.e. homozygous  $\beta^\circ$  thalassaemia

$\beta^\circ/\beta^+$ , i.e. heterozygous  $\beta$  thalassaemia

$\beta^+/\beta^+$ , i.e. homozygous  $\beta^+$  thalassaemia (most forms cause major disease).

In infants with  $\beta$  thalassaemia major, HbF is not replaced by HbA. This results in the development of severe haemolytic anaemia, hepatosplenomegaly and skeletal deformities (e.g. thickening of skull) due to extramedullary erythropoiesis. There is failure to thrive and the anaemic infant is prone to infections. Regular blood transfusion with treatment to control iron overload are required to sustain life. Without treatment, death usually occurs in childhood.

*Laboratory features*: Blood film shows marked poikilocytosis and anisocytosis with red cell fragments, many target cells, hypochromic cells, basophilic stippling, and nucleated red cells (see Colour Plate 105). There is usually a slight reticulocytosis.

The MCV, MCHC and MCH are reduced. There is erythroid hyperplasia and the reticuloendothelial cells in the bone marrow contain large amounts of iron. Serum ferritin and serum iron levels are increased. In  $\beta^\circ/\beta^\circ$ , haemoglobin is mainly HbF (98%) and HbA<sub>2</sub> (trace). There is a small amount of HbA when the genotype is  $\beta^\circ/\beta^+$  or  $\beta^+/\beta^+$ .

**Chart 8.3 Clinical classification and summary of laboratory features of some thalassaemia syndromes**

Thalassaemia major	ANAEMIA	HAEMOGLOBIN	BLOOD FILM
<b>■ BETA THALASSAEMIA</b> Homozygous $\beta^0$ thalassaemia ( $\beta^0/\beta^0$ ) Homozygous $\beta^+$ thalassaemia ( $\beta^+/\beta^+$ ) Heterozygous $\beta$ thalassaemia ( $\beta^0/\beta^+$ )	Severe, haemolytic anaemia, transfusion dependent MCV ↓ MCH ↓ MCHC ↓	$\beta^0/\beta^0$ : HbF 98%, HbA <sub>2</sub> present No HbA Other forms: HbF 60–95%, HbA <sub>2</sub> and HbA present	Marked anisocytosis, poikilocytosis Red cell fragments, nucleated red cells, basophilic stippling, target cells, hypochromic cells
<b>■ ALPHA THALASSAEMIA</b> Homozygous $\alpha^0$ thalassaemia (-/-) i.e. HbBarts hydrops syndrome	Severe fetal anaemia, incompatible with life	Hb Barts >80%. HbH, Hb Portland present. No HbA or HbF	Marked hypochromia, anisocytosis poikilocytosis, microcytosis and nucleated red cells
<b>Thalassaemia intermedia</b>			
<b>■ BETA THALASSAEMIA</b> Homozygous $\beta^+$ thalassaemia ( $\beta^+/\beta^+$ )	Moderate to severe anaemia. Frequent transfusions are required	$\beta^+/\beta^+$ : HbF, 60–95%, HbA <sub>2</sub> and HbA present	Blood film similar to major disease but less marked abnormalities
HbE/ $\beta$ (Southeast Asia) <sup>1</sup>		HbE/ $\beta$ : 15–95%, HbF 5–85%, No HbA	Blood film similar to major disease
HbS/ $\beta^0$ (Mainly north Africa and west Africa)	MCV ↓ MCH ↓	HbS/ $\beta^0$ : HbS 75–90%, HbF 5–20%, HbA <sub>2</sub> ↑ No HbA	Similar to sickle cell anaemia
HbC/ $\beta$ (West Africa)	As above	HbS/ $\beta^+$ : HbS >50%, HbA 15–30% HbF ↑ HbA <sub>2</sub> ↑	Marked microcytosis, hypochromic cells and many target cells
<b>■ ALPHA THALASSAEMIA</b> HbH disease ( $\alpha^0/\alpha^+$ thalassaemia, -/- $\alpha$ )	As above	HbC/ $\beta$ : HbC 70–95%, HbF 5–10% ( $\beta^0$ ) HbA absent ( $\beta^0$ ) or present ( $\beta^+$ )	Hypochromic red cells with target cells, small dense cells and red cell fragments
		HbH 5–40%, HbA 60–95% with traces of Hb Barts, HbA <sub>2</sub> ↓	Microcytic hypochromic red cells. Reticulocytosis. Hb inclusion bodies in more than 30% red cells
<b>Thalassaemia minor</b>			
<b>■ BETA THALASSAEMIA</b> Heterozygous $\beta^0$ thalassaemia ( $\beta^0/\beta$ ) <sup>3</sup> Heterozygous $\beta^+$ thalassaemia ( $\beta^+/\beta$ ) <sup>2</sup>	Asymptomatic or mild anaemia MCV ↓ MCH ↓	Usually HbA <sub>2</sub> and HbF are raised	Microcytic hypochromic cells with target cells and basophilic stippling
<b>■ ALPHA THALASSAEMIA</b> Heterozygous $\alpha^+$ thalassaemia (- $\alpha/\alpha$ ) <sup>4</sup> Homozygous $\alpha^+$ thalassaemia (- $\alpha/\alpha$ ) <sup>4</sup> Heterozygous $\alpha^0$ thalassaemia (-/- $\alpha$ ) <sup>4</sup>	As above	No detectable Hb imbalance. Traces of Hb Barts	Red cells slightly microcytic and hypochromic. Serum iron and ferritin levels are normal

**Notes**

- Condition may also cause major disease.
- When heterozygous *beta* thalassaemia is present with HbS, the clinical symptoms of HbS/ $\beta^0$  and HbS/ $\beta^+$  are very different. HbS/ $\beta^0$  is more severe than S/ $\beta^+$  condition, resembling sickle cell anaemia. In both HbS/ $\beta^0$  and HbS/ $\beta^+$ , tests for HbS are positive.
- Causes *beta* thalassaemia trait. Raised HbA<sub>2</sub> and HbF levels and target cells can help to differentiate this condition from iron deficiency anaemia. HbA<sub>2</sub> value may be reduced to borderline or normal values when *beta* cell trait co-exists with iron deficiency due to reduced HbA<sub>2</sub> synthesis. The tests should be repeated after 3–4 months treatment with iron if *beta* cell trait is suspected.
- Causes *alpha* thalassaemia trait. Condition is diagnosed using molecular techniques (in a reference laboratory).

- $\beta$  Thalassaemia intermedia which is a less severe condition than  $\beta$  thalassaemia major and does not require regular blood transfusion for survival.

Genotypes that can cause intermedia disease include some forms of homozygous  $\beta^+$  thalassaemia and those in which a thalassaemic gene and abnormal haemoglobin gene are inherited such as HbS/ $\beta$  in areas where both HbS and  $\beta$  thalassaemia genes are found, HbE/ $\beta$  in Southeast Asia, HbC/ $\beta$  in West Africa. Intermedia disease can also be caused by  $\delta\beta$  thalassaemias and associated Hb Lepore disorders. Some HbE/ $\beta$  disorders can cause a disease similar to  $\beta$  thalassaemia major.

*Laboratory features:* Haemoglobin is not as low as in major disease, usually 70–80 g/l. Severe anaemia can develop during pregnancy or with infections. Blood film abnormalities in intermedia disease are less marked except in HbE/ $\beta$  thalassaemia when the blood film can resemble major disease. Electrophoresis is required to identify HbE/ $\beta$  thalassaemia.

HbS/ $\beta^o$  thalassaemia resembles sickle cell anaemia, however, the MCV and MCH are lower in HbS/ $\beta^o$  and HbA<sub>2</sub> is raised. No HbA is produced and up to 90% of haemoglobin is HbS. The condition is mainly found in north Africa and in populations of the Americas where there are descendants of both Africans and Mediterranean people. HbS/ $\beta^+$  thalassaemia is found in West Africa. Anaemia is mild to moderate. More than 50% of haemoglobin is HbS, HbA forms 15–30%, and HbF and HbA<sub>2</sub> are raised. Blood film shows hypochromic microcytic cells with many target cells. Sickle cell slide test and solubility test for HbS are positive in HbS/ $\beta$  thalassaemias.

*Note:* In HbAS, HbS is always less than 45% and HbA is more than HbS whereas in HbS/ $\beta^+$  thalassaemia, HbS is more than 50% and always more than HbA.

#### Asymptomatic $\beta$ thalassaemias

$\beta$  Thalassaemia minor (trait) resulting from the heterozygous inheritance of  $\beta^o$  or  $\beta^+$  thalassaemia genes ( $\beta^o/\beta$  or  $\beta^+/\beta$ ) is usually without clinical symptoms. There is often a mild microcytic hypochromic anaemia. The blood film may show target cells and coarse basophilic stippling. The condition is often detected by the low MCV, (when using an electronic blood cell analyzer). HbA<sub>2</sub> is raised in  $\beta$  thalassaemia minor.

Serum iron and serum ferritin are normal (in the absence of iron deficiency anaemia).

#### ABNORMAL HAEMOGLOBINS

Whereas thalassaemia syndromes are caused by abnormalities in the rate of production of  $\alpha$  and  $\beta$  haemoglobin chains, disorders due to abnormal haemoglobins are caused by structural changes in the chains, particularly the  $\beta$  globin chains. Clinically significant abnormal haemoglobins that can be found in tropical countries include:

- HbS which has a wide distribution in tropical Africa, parts of India, the Caribbean, Mediterranean region, Arabian peninsula, and elsewhere in people of African descent.
- HbC which is found only in West Africa and elsewhere in people of West African descent.
- HbD, particularly HbD<sup>Punjab</sup> which is found in north west India.
- HbE which is found in Southeast Asia and the Indian subcontinent.

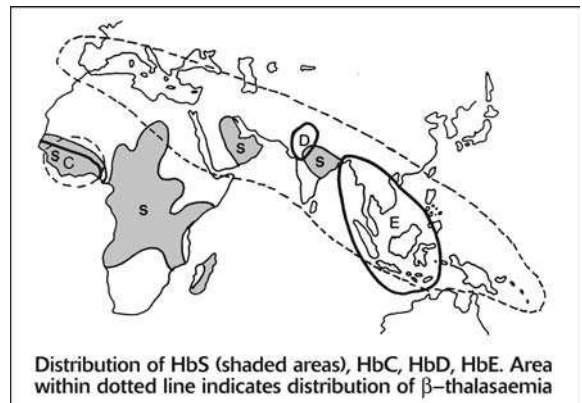

#### Haemoglobin S

HbS ( $\beta^S$ ) is formed when valine replaces glutamic acid in the  $\beta$  globin chain (6th amino acid position). In the deoxygenated state, HbS has poor solubility, forming polymers (long fibres) in red cells. Polymerization leads to changes in red cell membrane and metabolism, causing the cells to become rigid and distorted with a sickle shape. The sickled cells adhere to vascular endothelium and to one another, blocking small blood vessels. They become trapped in the spleen and haemolyze easily.

When the abnormal  $\beta^S$  gene is inherited from one parent and a normal  $\beta$  gene from the other parent (heterozygous state), the disorder is referred to as sickle cell trait ( $\beta^S/\beta$ ). This is mainly an asymptomatic condition with 50% or more of the person's haemoglobin being normal HbA. Under exceptional circumstances a sickle cell crisis can arise in persons

with sickle cell trait, e.g. at high altitudes, during prolonged anaesthesia or following strenuous exercise. The serious disorder sickle cell anaemia ( $\beta^S/\beta^S$ ) is caused when a person inherits the  $\beta^S$  gene from both parents (homozygous state).

*Note:* The term sickle cell disease is used to describe sickle cell anaemia (HbSS) and the range of HbS related disorders of similar clinical severity, e.g. when HbS is inherited with HbC, HbD<sup>Punjab</sup>, or HbO<sup>Arab</sup>. Sickle cell disease can also occur when HbS is inherited with  $\beta^0$  thalassaemia gene (common in North Africa).

**Clinical features of sickle cell disease:** These include haemolytic anaemia, jaundice, fever, painful swelling of hands and feet, skeletal changes due to erythroid hyperplasia, painful infarcts, pulmonary complications, kidney damage, leg ulcers, increased risk of *Salmonella* and pneumococcal infections, visual impairment, gallstones, haemolytic and aplastic crises. Acute falciparum malaria, can lead to severe anaemia and parvovirus infection can cause a severe aplastic crisis. Pregnant women with sickle cell disease are at risk of pre-term labour, abortion, stillbirth, anaemic and infarctive crises, and infections especially after delivery. High HbF levels lessen the severe affects of sickle cell disease.

*Note:* Blood transfusion is usually only required when there is a haemolytic or aplastic crisis. When the haemoglobin level is 60–80 g/l, oxygenation of the tissues is adequate because in sickle cell anaemia, the red cells contain an increased level of 2, 3 DPG which lowers oxygen affinity.

*Laboratory features:* In sickle cell anaemia, the haemoglobin is low. In a haemolytic and aplastic crisis, anaemia can become life-threatening. The thin blood film shows marked poikilocytosis with sickle cells, nucleated red cells, and target cells. Macrocytes may also be present due to folate deficiency. There is a marked polychromasia due to a high reticulocyte count. \*A typical sickle cell anaemia blood picture is shown in colour Plate 99.

**\*Thick blood film:** Heavy blue stippling in the background (see colour Plate 102) indicates a high reticulocyte count. When this is seen and the blood film is from a child in an HbS prevalent area, a thin film should always be examined for sickle cell anaemia.

The total white cell count is usually raised showing a neutrophilia often with a left shift. Following an infarctive crisis, white cell numbers are greatly increased and also platelets. The sickle cell slide test and solubility tube test for HbS are positive (see subunit 8.10). Sickle cell anaemia and other forms of sickle cell disease can be diagnosed by haemoglobin electrophoresis (see subunit 8.10). In sickle cell anaemia over 80% of the haemoglobin is HbS and the remainder, HbF and HbA<sub>2</sub>. HbA is absent. Haematuria may occur with sickle cells being

detected microscopically in urine.

In persons with sickle cell trait, the blood film usually shows target cells and tests for HbS are positive (see subunit 8.10). HbS forms about 35–45% of haemoglobin and HbA, 50–65%. Where  $\alpha$  thalassaemia genes are inherited, less than 35% of haemoglobin is HbS. Children with sickle cell trait are partially protected against severe life-threatening falciparum malaria.

#### **Protection afforded to HbAS carriers against severe falciparum malaria**

In areas where falciparum malaria is endemic, sickle cell trait carriers have lower parasite densities and are more protected against death from severe malaria and the development of hyper-reactive malarial splenomegaly, compared with HbAA and HbSS individuals. The advantage enjoyed by heterozygotes (HbAS) over that of both normal homozygotes (HbAA) and abnormal homozygotes (HbSS) is referred to as balanced polymorphism and is responsible for the high frequency of the HbS gene among populations where falciparum is or was endemic.

*Note:* Besides the HbS gene, other genes that reach polymorphic frequency where falciparum is or was endemic include those for HbC, HbD, HbE, and some forms of thalassaemia and G6PD deficiency. Genes for ovalocytosis in Southeast Asia and probably elliptocytosis in North Africa and West Africa also offer protection against severe falciparum malaria.

#### **Haemoglobin C**

HbC is found in West Africa and elsewhere in people of West African descent, e.g. the Caribbean. It is formed when glutamic acid is replaced by lysine in the  $\beta$  globin chain. Homozygous inheritance ( $\beta^C/\beta^C$ ) causes mild haemolytic anaemia and splenomegaly and protects against severe falciparum malaria (heterozygotes less protected). The blood film shows many target cells and occasionally red cells containing crystals of precipitated HbC.

When HbC is inherited with HbS ( $\beta^S/\beta^C$ ), the condition can cause symptoms similar to but less severe than sickle cell anaemia. Splenomegaly is more common than in HbSS. Eye disease is common. In some patients, HbSC disease causes only a mild haemolytic anaemia. Crises can arise during pregnancy. In HbSC disease, the blood film shows anisocytosis and poikilocytosis with small dense cells, many target cells, and occasionally sickle cells and cells containing HbC crystals. Tests for HbS are positive and alkaline electrophoresis shows HbC (slow moving) and HbS bands.

#### **Haemoglobin D<sup>Punjab</sup>**

HbD<sup>Punjab</sup> is important clinically because of its interaction with HbS. In HbSD<sup>Punjab</sup> disease there is moderate to severe haemolytic anaemia and the blood film is similar to that seen in sickle cell anaemia. Sickle cell tests are positive (solubility test

result similar to that seen with sickle cell trait). On alkaline electrophoresis, HbD<sup>Punjab</sup> (and other forms of HbD) have the same mobility as HbS. The two bands can be separated by agar gel acid electrophoresis with the HbD band showing in the same position as HbA.

### Haemoglobin E

Geographically HbE is found in a band stretching from Nepal to Indonesia. It is particularly prevalent in Southeast Asia. Homozygous inheritance of HbE causes only mild anaemia. The blood film shows microcytosis and hypochromia with target cells (similar to thalassaemia trait). When HbE is inherited with  $\beta$  thalassaemia (HbE/ $\beta^0$  or HbE/ $\beta^+$ ), however, this can cause  $\beta$  thalassaemia intermedia and occasionally  $\beta$  thalassaemia major (see previous text). HbE has the same mobility as HbC, using alkaline electrophoresis. With HbE/ $\beta^0$  thalassaemia, HbE and HbF are present. With HbE/ $\beta^+$  thalassaemia, HbE, HbF, and HbA are present.

### G6PD DEFICIENCY

G6PD deficiency is the commonest of the inherited red cell enzyme disorders. Deficiency of the enzyme glucose-6-phosphate hydrogenase (G6PD) in red cells reduces the ability of the cells to withstand lysis from oxidant damage, particularly during infections (e.g. pneumonia, viral hepatitis) and following exposure to oxidant drugs or chemicals.\*

\*G6PD is involved in the generation of phosphorylated nicotinamide-adenine dinucleotide (NADPH) in the pentose phosphate pathway (hexose monophosphate shunt). NADPH is needed to provide glutathione (GSH) which maintains haemoglobin and other red cell proteins in a reduced active form. Exposure to an oxidant drug (see following text) increases the need for NADPH and GSH. G6PD deficiency prevents this need from being met, resulting in the oxidation of haemoglobin to methaemoglobin. This precipitates to form Heinz bodies which attach to the red cell membrane. Cells containing Heinz bodies are easily damaged and lysed extravascularly and intravascularly.

#### Drugs associated with oxidant stress which may cause acute haemolysis in some G6PD deficient persons (usually 2–3 days following ingestion)

Aspirin (high doses)	Sulphonamides
Phenacetin	Nitrofurantoin
Quinine	Chloramphenicol
Chloroquine	Quinolones
Primaquine	<i>Para</i> -aminosalicylic acid
Dapsone	Some anti-helminth drugs

G6PD deficiency is found commonly in Africa (and elsewhere among people of African descent), India, southeast Asia, southern China, Middle East, and the Mediterranean region. It is an inherited disorder

carried on the X chromosome, therefore males are mainly affected. Occasionally homozygous females are also affected clinically.

*Note:* Deficiency of G6PD in heterozygous females provides some protection against severe malaria where *P. falciparum* is or was endemic.

#### Clinical importance of G6PD deficiency

Complications of G6PD deficiency are neonatal, jaundice, infection-induced jaundice, drug induced haemolysis and favism (Mediterranean type).

The severity of disease arising from G6PD deficiency depends on the defective G6PD gene inherited. Although there are many variants of G6PD with low enzyme activity, only a few G6PD isoenzymes cause significant clinical symptoms. The African A-G6PD variant causes self-limiting haemolytic anaemia following the ingestion of oxidant drugs. This is because low G6PD activity is found only in more mature red cells (reticulocytes contain normal levels of G6PD).

Elsewhere, where the type of G6PD variant inherited is associated with low enzyme activity in both reticulocytes and mature red cells (e.g. Mediterranean type), intravascular haemolysis can be severe and life-threatening following oxidant stress. Ingestion of fava beans (broad beans) or inhalation of pollen from the fava plant can precipitate a severe haemolytic crisis with haemoglobinuria. Favism commonly affects young children. G6PD deficient infants are frequently jaundiced.

#### Laboratory investigation of G6PD deficiency

In the investigation of anaemia caused by G6PD deficiency, it is important to obtain a clinical history and information on the drugs, chemicals, and vegetables recently ingested by the patient. During a haemolytic crisis, the haemoglobin level may fall rapidly (recovering after 7–10 days when patient has type A-G6PD deficiency). Haemoglobinuria is found when there is severe intravascular haemolysis. The following tests are the most useful to perform during a crisis:

- Measurement of haemoglobin and test to detect haemoglobin in urine.
- Blood film (see colour Plate 107): During a haemolytic crisis the blood shows marked polychromasia and poikilocytosis with small irregular contracted cells, some with bitten out margins i.e. 'bite' cells (where Heinz body has been removed by splenic macrophages). Other cells show protrusions due to Heinz body inclusions or irregularly distributed haemoglobin with one half of the cell appearing empty (half-ghost cells).
- Reticulocyte preparation to count reticulocytes and to look for Heinz bodies (see subunit 8.9).

*Following a haemolytic crisis when reticulocyte numbers have returned to normal:*

Perform a screening test such as the methaemglo-

bin reduction test to detect low G6PD activity in red cells (see subunit 8.9).

**HEREDITARY RED CELL MEMBRANE DISORDERS**

These include:

- Hereditary spherocytosis, which usually causes only a mild chronic haemolytic anaemia with splenomegaly. Obstructive jaundice due to gallstones is a common complication. Red cells have a reduced life span. Anaemia can become more severe when there is also folate deficiency, anaemia of chronic disease and aplastic crisis induced by parvovirus B<sub>19</sub> infection.

The blood film shows spherocytes (which may be scanty) with polychromasia. The osmotic fragility test shows increased fragility of the cells, particularly following 24 h incubation. The direct antiglobulin test (DAT) is negative which helps to differentiate this condition from immune causes of spherocytosis in which the DAT is positive.

- Hereditary elliptocytosis which may cause mild anaemia in homozygotes. It is found in West and North Africa. A haemolytic crisis may occur during serious infections, e.g. malaria. The blood film typically shows elliptocytes (elongated red cells) and also red cell fragments.
- Hereditary ovalocytosis, a common disorder in Southeast Asia, Indonesia, Philippines and Melanesia. In heterozygotes, it is usually an asymptomatic condition (lethal in homozygotes). The blood film contains large numbers of ovalocytes (see colour Plate 104).

**POLYCYTHAEMIA**

Polycythaemia (erythrocytosis) is associated with a raised haemoglobin, PCV, and red cell count (values above those normal for age and gender). Depending on cause(s), the condition is described as:

- True polycythaemia in which the total volume of circulating red cells is increased. This can be:
  - Primary*, as in polycythaemia vera which is a myeloproliferative disorder in which mature erythroid cells are increased (absolute increase in red cell mass) and usually also platelets and granulocytic cells. Whole blood viscosity is increased and there is splenomegaly. The condition usually develops into myelofibrosis or acute myeloblastic leukaemia (see later text).

*Secondary*, caused by a raised level of erythropoietin as occurs for example in renal disease or hypoxia associated with respiratory failure, cyanotic heart disease, and high altitudes.

- Apparent, or relative, polycythaemia in which there is a temporary decrease in total plasma volume (total red cell mass is not increased). Common causes include shock, burns, or acute dehydration as occurs in severe diarrhoea, or vomiting, and acute alcohol poisoning.

**WHITE CELLS**

In an adult there are about  $4.0-11.0 \times 10^9$  white cells (leukocytes) per litre of blood, composed of:

Neutrophils	.....	$1.5-7.5 \times 10^9/l$
Lymphocytes	.....	$1.2-4.0 \times 10^9/l$
Monocytes	.....	$0.2-1.0 \times 10^9/l$
Eosinophils	.....	$0.02-0.6 \times 10^9/l$
Basophils	.....	$0.01-0.1 \times 10^9/l$

*Note:* The above figures are guideline figures only. White cell total counts and neutrophil counts vary between different populations and there are also gender differences as explained in subunit 8.6.

**Neutrophils\***

\*Also referred to as polymorphonuclear (many shaped nucleus) neutrophils, or simply polymorphs.

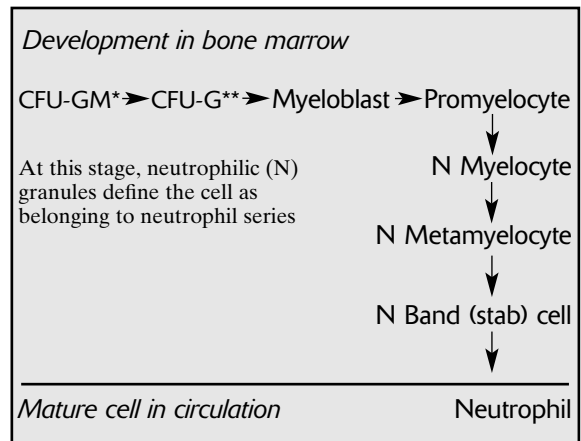

\*Colony-forming unit-granulocyte monocyte progenitor cell  
 \*\*Colony-forming unit-granulocyte

*Morphology*  
**Myeloblast:** Measures about 15 µm in diameter. It has a large nucleus with fine chromatin, 2-5 nucleoli and scanty pale blue cytoplasm without granules.

**Promyelocyte:** Slightly larger than a myeloblast with more condensed nucleus and less clear nucleoli. Cytoplasm is less basophilic and contains both azurophilic granules and

characteristic *neutrophilic granules*. Azurophilic granules contain lysosomal enzymes (e.g. peroxidase) and antibacterial proteins. Neutrophilic granules contain lactoferrin, collagenase, and miramidase.

**Myelocyte:** Smaller than a promyelocyte, measuring 12–18  $\mu\text{m}$  in diameter. The nucleus is usually oval and without nucleoli. The pale staining cytoplasm contains azurophilic and neutrophilic granules.

**Metamyelocyte:** Measures 10–12  $\mu\text{m}$  in diameter. The nucleus is indented (U-shaped) and the cytoplasm is pale pink and contains neutrophilic granules. A metamyelocyte is shown in colour Plate 85.

**Band cell (stab form):** Similar to the metamyelocyte but with a curved or coiled, often S shaped nucleus (without clear lobes), as shown in colour Plate 86.

**Neutrophil:** Measures 12–15  $\mu\text{m}$  in diameter. The nucleus has 3 (occasionally 4 or 5) clear lobes, separated by chromatin threads. The cytoplasm is pale staining and contains neutrophilic i.e. mauve staining granules. In blood films from women, the nucleus of some neutrophils may show a small protrusion ('drum-stick'). A neutrophil in a stained blood film is shown in colour Plate 81.

#### *Functions of neutrophils*

The bone marrow contains a large pool of neutrophils. From the bone marrow, neutrophils enter the blood.\*

\*About half the neutrophils in the blood, circulate forming the circulatory pool (included in WBC count). The other half, marginate along the walls of blood vessels and in capillaries, forming the marginating pool (not included in WBC count). Increased numbers of neutrophils in the marginating pool may explain the lower circulating neutrophil counts frequently found in African people.

Neutrophils have a short life-span. After circulating in the blood for 6–10 hours they pass into the tissues where as highly mobile phagocytes they are important in defending the body from infection. They mobilize and migrate to sites of infection or inflammation, chemically attracted by substances released by bacteria, complement components, damaged tissue, and other leukocytes (process called chemotaxis).

Neutrophils have receptors for IgG antibody and complement (C3b) and are therefore able to recognize, phagocytose, and kill bacteria coated with IgG or C3b (see also subunit 7.2). Bacteria are ingested and destroyed within a phagocytic vacuole following the release of chemicals from neutrophil granules. Following phagocytosis, neutrophils die at the site of infection, forming pus cells. Neutrophils not involved in the inflammatory process are removed by the spleen after 1–2 days.

Increases in the number of circulating neu-

trophils (neutrophilia) is usually an indication of infection or tissue damage, particularly when accompanied by circulating neutrophil precursor cells (left shift) and in severe pyogenic infections, by toxic changes including coarser darker staining granules (toxic granulation) as shown in colour Plate 86 and vacuolation of cells. Other causes of neutrophilia and abnormalities of neutrophils are described in subunit 8.7.

The term leucoerythroblastic blood picture is used when nucleated red cells are seen with myeloid precursor cells in the blood film. Neutrophils having six or more lobes can be found in megaloblastic anaemia (see colour Plate 97). A reduction in circulating neutrophils (neutropenia) occurs with bone marrow failure, some drug treatments, HIV disease and some bacterial infections as summarized in subunit 8.7.

## **Eosinophils**

### *Development*

Eosinophils like neutrophils, originate, differentiate, and mature in the bone marrow.

### *Morphology*

Morphologically, early eosinophil precursor cells (myeloblast, promyelocyte) have a similar appearance to those previously described for neutrophils. Mature eosinophil myelocytes can be recognized by their large orange-red staining (eosinophilic) granules. These specific granules contain major basic protein, peroxidase, perforins and other membrane-damaging substances.

**Eosinophil:** Slightly larger than a neutrophil, measuring 12–17  $\mu\text{m}$  in diameter. The nucleus of most eosinophils has two lobes (occasionally three). The cytoplasm contains many large round orange-red granules and occasionally vacuoles. Eosinophils in a stained blood film are shown in colour Plate 82.

### *Functions of eosinophils*

Eosinophils enter the blood from the bone marrow. They circulate for about 8 hours after which they enter the tissues. They are found mainly in the skin, gastrointestinal tract and lungs where they are involved in hypersensitivity reactions, e.g. asthma, hay fever, eczema. Eosinophils contain substances that are able to inactivate histamine and factors released during anaphylaxis.

Eosinophils are important in parasitic helminth immune responses in which IgG and IgE antibodies are produced. Lymphokines released from T lymphocytes stimulate the production of IgE which binds to mast cells at the site of parasitic infection.

Parasitic antigens cause chemotactic substances to be released from mast cells which attract eosinophils to the site. Eosinophils bind to the antibody-coated parasite and release cytotoxic substances which damage the surface of the parasite, leading to its destruction.

Antibody dependent cell-mediated cytotoxicity by eosinophils is effective against parasites which are located in the tissues, or have a tissue invading stage, e.g. schistosomes, filarial worms, hookworms, *Trichinella*, *Strongyloides*, *Ascaris*, *Fasciola*, *Fasciolopsis*, *Paragonimus*, and *Toxocara*.

Increases in eosinophil numbers (eosinophilia) are therefore found in some helminth infections, and also in allergic disorders and other conditions in which serum IgE is increased (see subunit 8.7).

## Basophils

### Development

Basophils like neutrophils and eosinophils, originate, differentiate and mature in the bone marrow.

### Morphology

Morphologically, early basophil precursor cells (myeloblast, promyelocyte) resemble those previously described for neutrophils. Basophil myelocytes can be recognized (but are rarely seen) by the specific dark purple-black (basophilic) granules. Basophilic granules contain heparin, histamine and peroxidase.

**Basophil:** Measures 10–12  $\mu\text{m}$ . The nucleus is usually bilobed but is obscured by large, irregular in size basophilic granules as shown in colour Plate 84. The normal basophil count is less than  $0.1 \times 10^9/\text{l}$  and therefore basophils are not often seen in normal blood films.

### Functions of basophils

Basophils circulate only in the blood. They are not found in tissues (mast cells are tissue equivalents to basophils). Basophils bind IgE on their surface and are involved in anaphylactic, hypersensitivity, and inflammatory reactions.

Basophils interact with eosinophils and macrophages in allergic reactions. When specific antigen reacts with IgE bound to basophils, degranulation of the cells occurs with the release of inflammatory substances including heparin, histamine and platelet activating factor.

Increases in circulating basophils (basophilia) is found in myeloproliferative disorders, some leukaemias (especially chronic myeloid leukaemia), and occasionally in allergic disorders (see also subunit 8.7).

## Monocytes

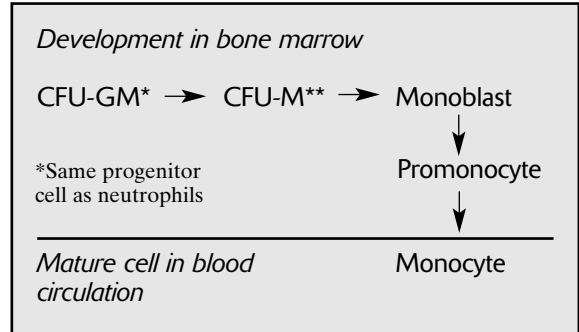

\*\*Colony-forming unit-monocyte

### Morphology

**Monoblast:** Large cell with abundant cytoplasm and a round or indented nucleus containing nucleoli (similar to myeloblast).

**Promonocyte:** Measures 15–20  $\mu\text{m}$  in diameter (larger than monoblast). The cytoplasm is basophilic and contains prominent azurophilic granules. The nucleus is oval or indented.

**Monocyte:** Largest of the circulating white cells, measuring 15–20  $\mu\text{m}$  in diameter, often with an irregular shape. The nucleus is large, often appearing indented or folded, mauve staining with a delicate chromatin pattern. The cytoplasm is a clear grey-blue and contains fine granules and occasionally vacuoles. Monocytes in a stained blood film are shown in colour Plates 81 and 83.

### Functions of monocytes and macrophages

Monocytes pass from the bone marrow into the blood circulation. Within 2–3 days they reach the tissues where they develop into macrophages, becoming fixed tissue macrophages in the spleen, liver (Küpfner cells), lymph nodes, connective tissues, and central nervous system, and free macrophages in lung alveoli, peritoneum and inflammatory granulomas. Macrophages form the mononuclear phagocytic system, i.e. reticuloendothelial (RE) system. Unlike neutrophils, mononuclear phagocytes do not die following phagocytosis. Macrophages live in the tissues for several months or longer.

As phagocytic cells, monocytes ingest microorganisms and cellular debris, including malaria pigment (see colour Plate 115). The RE system is involved in the destruction of bacteria, viruses, fungi, protozoal parasites, and malignant cells.

Macrophages process and present antigens to T lymphocytes, and regulate many T and B cell activities. When activated, macrophages synthesize and secrete cytokines (e.g. interleukins, tumour necrosis factor, GM-CSF) which are involved in the activation of lymphocytes, the inflammatory process (particularly chronic inflammation), cell-mediated immune



responses and haematopoiesis (see also subunit 7.2).

An increase in circulating monocytes (monocytosis) is found in protozoal parasitic infections, and also in tuberculosis and other chronic bacterial infections and rickettsial infections (see also subunit 8.7).

## Lymphocytes

The body produces two main types of lymphocyte to carry out specific immune responses:

- T lymphocytes which form 65–80% of lymphocytes in the blood with about two thirds being CD4<sup>+</sup> helper T cells and about one third, CD8<sup>+</sup> cytotoxic T cells.
- B lymphocytes which form 10–30% of lymphocytes in the blood.

**Non-B, non-T lymphocytes:** Make up to 2–10% of circulating lymphocytes. They include natural killer (NK) lymphocytes (see subunit 7.2).

having the same specificity) of effector cells and memory cells.

### *Morphology of lymphocytes in the blood*

In Romanowsky stained blood films it is not possible to differentiate between B and T lymphocytes. Morphologically, lymphocytes appear as small lymphocytes and large lymphocytes.

### **Small lymphocytes**

In the blood of an adult, most lymphocytes are small lymphocytes, measuring 10–12 µm in diameter. They have a round or irregular shaped dark mauve staining nucleus surrounded by a thin rim of blue cytoplasm as shown in colour Plate 83.

### **Large lymphocytes**

In an adult about 10% of circulating lymphocytes are large lymphocytes, measuring 12–16 µm in diameter. Compared with small lymphocytes, the nucleus of large lymphocytes stains paler and the cells have more cytoplasm (see colour Plate 81). Small azurophilic granules can often be seen in the cytoplasm. Blood films from children contain greater numbers of large lymphocytes (including reactive lymphocytes) and fewer small lymphocytes.

*Note:* Reactive (atypical) lymphocytes are described in subunit 8.7 and shown in colour Plate 94.

### *Functions of lymphocytes*

To function effectively as immune cells, lymphocytes (particularly T lymphocytes) recirculate from blood to lymph, passing through lymphoid tissues and then re-entering the venous blood by way of the lymphatic system and thoracic duct. As explained in subunit 7.2, lymphocytes are important cells in specific immune responses.

**CD4<sup>+</sup> helper T lymphocytes:** Secrete cytokines which stimulate B lymphocytes to develop into antibody-producing plasma cells. They also help to activate CD8<sup>+</sup> cytotoxic T lymphocytes, participate in delayed hypersensitivity reactions (with macrophages), and modulate cellular immune responses. CD4<sup>+</sup> helper T cells respond to (recognize) antigen bound to MHC (major histocompatibility complex) class II protein. Cells bearing MHC class II molecules are B lymphocytes and macrophages.

**CD8<sup>+</sup> cytotoxic lymphocytes:** Produce toxins which destroy tumour cells and cells infected with viruses and other microorganisms. CD8<sup>+</sup> T cells respond to antigen bound to MHC class I molecules on infected cells.

**B lymphocytes:** With the help of macrophages and CD4<sup>+</sup> T cells, B lymphocytes are responsible for antibody-mediated immunity. Antigen, e.g. bacterial antigen, is processed and presented (bound to MHC class II protein) on the surface of macro-

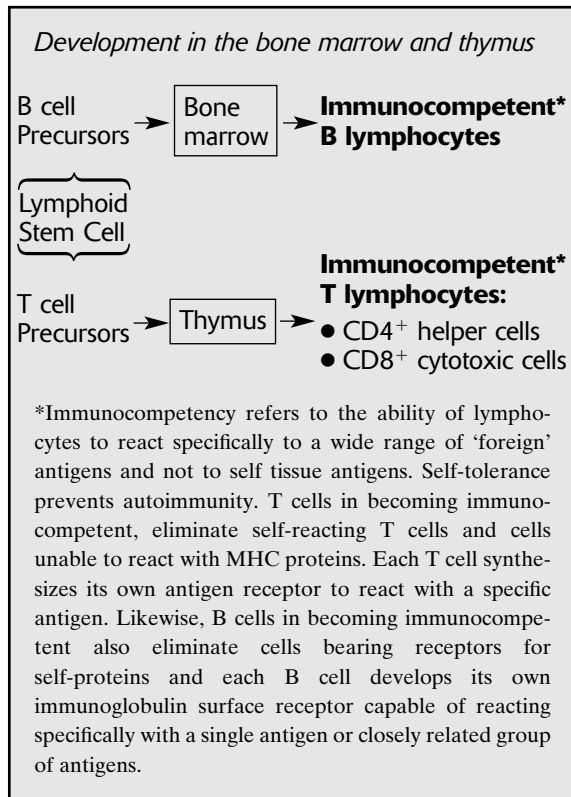

Following their development in the thymus and bone marrow (primary lymphoid tissue), B & T lymphocytes via the lymphatic system reach the spleen, lymph nodes, and other secondary lymphoid tissue. Following antigenic stimulation, they become sensitized and produce clones (populations of cells

phages. The antigen-MHC II protein complex binds to specific receptors on CD4<sup>+</sup> T cells. Cytokines are released by the CD4<sup>+</sup> cells which stimulate those B cells capable of producing antibody specific to the antigen. B cell stimulation results in the production of large numbers of specific antibody secreting plasma cells and B memory cells.

Most antibody formed during a primary antibody response is IgM, whereas antibody formed during a secondary antibody response (following activation of B memory cells) is IgG. Antibodies neutralize toxins and viruses and opsonize bacteria. Antibody with complement stimulates phagocytosis and the killing of pathogens.

*Note:* The main causes of increased numbers of circulating lymphocytes (lymphocytosis) and of reduced numbers (lymphopenia) are summarized in subunit 8.7.

### Disorders of white cells

The commonest disorders of white cells are:

- Absolute increases in leukocyte numbers, involving neutrophils, lymphocytes and eosinophils in response to bacterial, viral, or parasitic infections, tissue injury, and inflammation as summarized in subunit 8.7.
- Absolute decreases in leukocyte numbers involving neutrophils and lymphocytes, caused by some infections (especially HIV), hypersplenism, immune destruction of cells, treatment with cytotoxic drugs, bone marrow dysfunction, megaloblastic anaemia, collagen disorders, and malignant conditions (see subunit 8.7).

**Terminology:** An absolute increase in the total number of circulating leukocytes is called leukocytosis (leucocytosis) and an absolute decrease is called leukopenia (leucopenia).

Less common disorders of white cells include:

- Leukaemias
- Lymphomas
- Myelomatosis and related conditions

**HIV:** The haematological features found in HIV disease and AIDS are described in subunit 7.18.55.

## LEUKAEMIAS

Leukaemias are neoplastic clonal disorders of haematopoietic tissues in which a stem cell or other precursor blood cell in the bone marrow or lymphoid tissue proliferates. Clonal proliferation of the leukaemic cells and tissue infiltration, lead to the impairment or suppression of normal blood cell

production. Leukaemic cells do not function or mature normally.

### Transformation of cells

Transformation of haematopoietic cells may occur following ionizing radiation or exposure to chemicals such as benzene, infection with certain viruses, or treatment with cytotoxic drugs (e.g. alkylating agents). Hereditary factors may also be involved, e.g. factors that activate oncogenes (genes which are involved in producing malignant change) or chromosomal abnormalities such as deletions, major translocations or additional chromosomes. Some chromosomal changes have prognostic significance.

Based on whether the disease is acute (rapidly progressive) or chronic (slowly progressive) and whether the leukaemic cells are of myeloid or lymphoid origin, leukaemias can be broadly divided into:

- Acute myeloid leukaemia (AML)
- Acute lymphoblastic leukaemia (ALL)
- Chronic myeloid leukaemia (CML)
- Chronic lymphocytic leukaemia (CLL)

In acute leukaemias there is a clonal proliferation of blast cells (lymphoblasts in ALL, myeloblasts or monoblasts, or rarely erythroblasts and megakaryocytes, in AML) which are difficult to differentiate in Romanowsky stained bone marrow or blood films. Differentiation and treatment of acute leukaemias require specialist techniques including cytochemical-staining (differentiates myeloid and lymphoid cells), and when possible, monoclonal antibody cell marker studies (immunophenotyping) and chromosome studies (cytogenetics). In chronic leukaemias, the clone of tumour cells is sufficiently differentiated to be recognized in Romanowsky stained preparations, i.e. lymphocytic cells in CLL and myeloid cells in CML. In most but not all forms of leukaemia the total leukocyte count is raised with very high counts being found particularly in CML and CLL.

### Acute leukaemias (AML, ALL)

ALL is most often found in children (males more often than females). AML is usually more common in adults. In tropical Africa, however, AML and ALL are reported as having a similar frequency in children below 15 y.

In acute leukaemia the patient is anaemic, thrombocytopenic, neutropenic, and blast cells predominate in the bone marrow and can be seen in the blood film. Bone pain, fever, bleeding, purpura, thrombosis and hepatosplenomegaly are common and in ALL, also lymphadenopathy and central nervous system involvement (late stages of disease). In AML there is often inflammation of the gums,

skin involvement, and coagulation defects may occur in acute promyelocytic leukaemia. In tropical Africa, it is reported that up to 25% of patients with AML (mainly male children) develop a tumour (chloroma) of the face, particularly in the orbit. Untreated acute leukaemia is rapidly fatal with most patients dying from haemorrhage or infection due to bone marrow failure.

#### Differentiation between ALL and AML

The finding of Auer rods (needle or rod-like cytoplasmic inclusions) in blast cells is diagnostic of AML (see colour Plate 90), but these inclusions are not always present in myeloblasts. Differentiation between AML and ALL requires the facilities of a specialist haematology laboratory to perform cytochemical staining and immunophenotyping. An experienced haematologist is required to report bone marrow preparations and classify ALL and AML.

#### Cytochemical staining

- Lymphoblasts: Sudan black and myeloperoxidase negative and usually non-specific esterase (NSE) negative. The periodic-acid (PAS) stain is often positive.
- Myeloblasts: Sudan black and myeloperoxidase positive, PAS negative or diffusely positive. Monoblasts are strongly positive for NSE and myeloblasts are diffusely positive for NSE (resistant to inhibition by sodium fluoride). Monoblasts may be weakly PAS positive.

*Note:* Details of cytochemical staining techniques, immunophenotyping (monoclonal antibody cell marker studies) and cytogenetic studies used to differentiate acute leukaemias can be found in *Practical Haematology* and other haematology textbooks (see Further information).

*Note:* The main laboratory features of AML and ALL are summarized in Chart 8.4.

#### Chronic lymphocytic leukaemia (CLL)

In most forms of CLL there is a clonal proliferation of B lymphocytes. Occasionally T lymphocyte CLL occurs. B cell CLL is rare in India and parts of Asia. CLL may be misdiagnosed as hairy-cell leukaemia or prolymphocytic leukaemia (see Chart 8.4). CLL is more often found in older persons (over 60 y) with more men affected than women. In tropical Africa, CLL is also found in younger people. A lymphoproliferative disorder may occur predominantly in young to middle aged women associated with hyper-reactive malarial splenomegaly.

#### Clinical features of CLL

Onset of disease is slow and in the early stages, asymptomatic. Most patients have weight loss, and develop lymphadenopathy and hepatosplenomegaly (especially splenomegaly in malaria endemic areas). In the later stages of CLL, neutropenia, thrombocytopenia and the loss of normal functioning lymphocytes, lead to inadequate immune responses resulting in bacterial, fungal, and viral infections. Anaemia

develops, particularly due to hypersplenism and autoimmune haemolysis and also thrombocytopenia as bone marrow failure develops.

#### Staging of CLL

CLL is staged from 0-IV based on the absolute lymphocyte count and the presence of enlarged lymph nodes, liver or spleen, anaemia and thrombocytopenia. A patient is classified as stage IV when all the features are present and stage 0 when there is only an absolute lymphocytosis (monoclonal lymphocytes).

*Note:* CLL does not usually develop into acute lymphoblastic leukaemia. Patients die from immune deficiency, infection, bone marrow failure, or infiltration of vital organs. The main laboratory features of CLL are summarized in Chart 8.4.

#### Chronic myeloid leukaemia (CML)

In CML there is proliferation of myeloid cells. The abnormal Philadelphia (Ph) chromosome\* is present in the leukaemic cells of more than 95% of patients with CML (also in 5–25% of patients with ALL).

\*Formed by a translocation of the long arm from chromosome 22 to the long arm of chromosome 9. It is associated with activation of the *BCR-ABL* oncogene.

In developing countries CML is common in younger people and children.

#### Clinical features of CML

In the early stages of CML (chronic stage), patients usually have few clinical symptoms. Splenomegaly, lethargy, and weight loss are common. CML develops into AML (see previous text) which is preceded by an accelerated stage. The spleen and liver enlarge, and there is anaemia, thrombocytopenia with bleeding tendency, fever, sweats and bone pain.

*Note:* CML is characterized by a greatly increased leukocyte count, up to  $300 \times 10^9/l$  or more. Other laboratory features of CML are summarized in Chart 8.4.

#### Leukaemoid reactions

In response to severe infections, malignancies, burns, and other conditions, patients may have high white cell counts and blood films which resemble those seen in chronic leukaemias.

*Leukaemoid reactions resembling CML* can occur in tuberculosis, meningococcal meningitis, septicaemia, severe megaloblastic anaemia in pregnancy, eclampsia, acute hepatic necrosis, amoebic liver abscess, burns and following severe haemorrhage.

An AML-like picture can be seen with severe pulmonary or extrapulmonary tuberculosis. The main features which differentiate a leukaemoid reaction from CML are as follows:

	<i>Leukaemoid Reaction</i>	<i>CML</i>
● Total WBC	Rarely more than $60 \times 10^9/l$	$50-500 \times 10^9/l$
● Left shift	Present, usually with toxic granulation and neutrophil vacuolation	More prominent than in leukaemoid reaction. No toxic granulation. Blast cells may be seen.
● Eosinophils and basophils	Reduced or normal	Increased
● Neutrophil alkaline phosphatase score	Increased	Reduced

*Leukaemoid reactions resembling ALL* can occur in miliary tuberculosis, measles, whooping cough, chicken pox, syphilis, infectious mononucleosis and malaria.

A CLL-like blood picture can be seen with hyperactive malarial splenomegaly.

Infants infected with the hookworm *A. duodenale* can have an eosinophil leukaemoid reaction.

*Note:* With recovery, a leukaemoid reaction resolves.

## LYMPHOMAS

Lymphomas are clonal proliferation disorders of lymphoid tissue (lymph nodes, spleen, mucosal lymphoid tissue). They are divided into:

- *Hodgkins lymphoma:* Characterized by a proliferation of lymphoid cells with enlargement of lymph nodes usually in the neck or axillae. In this form of lymphoma, the lymph nodes are infiltrated by large malignant cells called Reed-Sternberg (RS) cells\*.

\*RS cells are typically binucleate cells (sometimes mononucleate or multi-nucleate) with prominent nucleoli, abundant cytoplasm and often surrounded by a clear area.

A diagnosis of Hodgkins lymphoma is made by identifying RS cells in stained sections of lymph node tissue (in a reference Histology Laboratory), combined with the histological appearance of the lymph node (cellular composition and inflammatory pattern). Epstein Barr virus (EBV), i.e. human herpes virus 4, is associated with severe types of Hodgkins lymphoma with the virus being present in about 50% of RS cells (higher percentage in tropical countries).

- *Non-Hodgkins lymphomas:* Include the solid tumours of lymphoid tissue of which the majority

(about 85%) are B-cell malignancies and the remainder are of T cell origin. In tropical countries the most important non-Hodgkins lymphoma is Burkitt's lymphoma (B-cell) which can be diagnosed cytologically from 'touch smears' (see following text).

### Burkitt's lymphoma (BL)

BL is endemic in tropical Africa and Papua New Guinea where it is found mainly in children aged 4-9y (with males being more affected than females). It commonly occurs as a tumour of the face and jaw, and sometimes as an abdominal tumour. BL is also found in north Africa, Pakistan, South America, and sporadically in other countries. BL may occur in patients with advanced HIV/AIDS.

#### Cause of Burkitt's lymphoma

BL is associated with EBV, with the virus being found in most tumour cells in patients from BL endemic areas. Chromosome deletions are thought to be involved in the development of BL (activating the *c-myc* oncogene) and in tropical countries, falciparum malaria may also be a cofactor (immunosuppressive effects). BL distribution closely follows that of malaria.

BL can be diagnosed cytologically by examining Giemsa stained smears (touch or imprint smears) of aspirated tumour material or ascitic fluid for tumour cells. BL cells are large, have an immature nucleus containing nucleoli and deep blue staining cytoplasm which contains vacuoles as shown in colour Plate 92. Vacuoles may be seen also in the nucleus. In haematoxylin-eosin stained tissue sections of tumour, BL shows a typical 'starry night' appearance with pale staining phagocytic macrophages being seen against a background of dark-staining malignant lymphocytes.

### Adult T-cell leukaemia lymphoma (ATLL)

HTLV-1 (human T-cell lymphotropic virus) is associated with T-cell leukaemia lymphoma and a degenerative neurological disease known as tropical spastic paraparesis (TSP). It is most common in southern Japan, West Indies, and South America, and it has also been reported from the Middle East, west central Africa, Central America, among Aboriginal people in Australia, and parts of Europe. In ATLL, the blood, bone marrow, and other tissues are infiltrated by T-cell lymphoma cells infected with HTLV-1 (a retrovirus). The virus can be transmitted by sexual intercourse, by vertical transmission from mother to child, by breastfeeding, transfusion of HTLV-1 infected blood, and by the use of HTLV-1 contaminated needles, e.g. among intravenous drug users. Most people develop ATLL late in life following earlier exposure to HTLV-1.

Chart 8.4 Main laboratory features of acute and chronic leukaemias

	WBC Count	Hb	Platelets	Blood Film	Bone Marrow	Other
<b>ACUTE LEUKAEMIAS</b>						
<b>Acute lymphoblastic leukaemia (ALL)</b>	↑ 15–100 × 10 <sup>9</sup> /l but can be normal	↓ N/N	↓ With bleeding and purpura	<ul style="list-style-type: none"> <li>● Lymphoblasts present</li> <li>● Neutropenia</li> </ul>	<ul style="list-style-type: none"> <li>● Hypercellular with lymphoblasts and lymphocytes.</li> </ul>	<ul style="list-style-type: none"> <li>● SB: Negative</li> <li>● MLP: Negative</li> <li>● PAS: Often positive</li> </ul> <p>T cell ALL: Acid phosphatase and NSE positive</p>
<b>Acute myeloid leukaemia (AML)</b>	↑ 15–100 × 10 <sup>9</sup> /l but can be normal	↓ N/N	↓ With bleeding and purpura	<ul style="list-style-type: none"> <li>● Blast cells present</li> <li>● Auer rods may be seen in myeloblasts</li> <li>● Rest of myeloid cells may be morphologically abnormal</li> </ul>	<ul style="list-style-type: none"> <li>● Hypercellular. Myeloblasts predominate (&gt;30% of nucleated cells)</li> <li>● FAB Classification: M0–M7 (in reference laboratory)</li> </ul>	<ul style="list-style-type: none"> <li>● SB: Positive</li> <li>● MLP: Positive</li> <li>● PAS: Neg/Pos with M4, M5</li> </ul>
<b>CHRONIC LEUKAEMIAS</b>						
<b>Chronic lymphocytic leukaemia (CLL)</b>	↑ 50–200 × 10 <sup>9</sup> /l	Moderately low, N/N	↓ In late stages	<ul style="list-style-type: none"> <li>● Absolute lymphocytosis</li> <li>● Small lymphs with coarse chromatin</li> <li>● Smear cells are seen<sup>1</sup></li> </ul> <p><b>Hairy cell leukaemia:</b> Lymphs have a 'hairy' outline and oval nucleus</p> <p><b>Prolymphocytic leukaemia:</b> Lymphs are larger with prominent nucleolus</p>	<ul style="list-style-type: none"> <li>● Hypercellular with mature small lymphs and larger lymphoid cells</li> <li>● Lymphs make up 25–95% of all the cells</li> </ul>	<ul style="list-style-type: none"> <li>● Occasionally positive DAT</li> <li>● Immunophenotyping required to confirm B cell CLL</li> </ul>
<b>Chronic myeloid leukaemia (CML)</b> ■ Chronic stage	↑ 50–500 × 10 <sup>9</sup> /l  <b>Leukaemoid reaction</b> WBC rarely more than 60 × 10 <sup>9</sup> /l, see main text	↓ N/N may be normal	↑ In about 30% of patients, or normal, becoming low	<ul style="list-style-type: none"> <li>● Neutrophils predominate</li> <li>● Marked left shift, with metamyelocytes, myelocytes, promyelocytes seen. Occasional blast cell</li> <li>● Often eosinophils and basophils increased</li> </ul>	<ul style="list-style-type: none"> <li>● Hypercellular with mature and immature myeloid cells. Less than 5% blast cells</li> </ul>	<ul style="list-style-type: none"> <li>● Philadelphia chromosome, t(9;22) present in 95% CML patients</li> <li>● NAP score reduced</li> </ul>
■ Accelerated/acute stage <sup>2</sup>	See AML	See AML	See AML	More immature cells with increase in blast cells and often basophils	More blast cells with 30% or more indicating AML	NAP score rises

**Notes:**

1 Smear or smudge cells are leukaemic lymphocytes that have become damaged when spreading the blood film (see Colour Plate 87).

2 Occasionally lymphoid blast crisis occurs instead of myeloid blast crisis.

N/N = Normocytic normochromic anaemia, SB = Sudan black stain, MLP = Myeloperoxidase, PAS = Periodic-acid stain, NSE = Non-specific esterase, NAP = Neutrophil alkaline phosphatase, Hb = Haemoglobin, ↓ = Reduced, ↑ = Increased.

*Clinical features of ATLL:* Include tumours, infections, lymphadenopathy, hepatosplenomegaly, skin lesions, ulcers, and lytic bone lesions with associated hypercalcaemia. Based on clinical features and cell morphology, four clinical subtypes are recognized, acute, chronic, smouldering ATLL, and lymphoma/leukaemia subtypes. ATLL has a poor prognosis.

In HTLV-1 associated ATLL, there is a positive HTLV-1 antibody test. Depending on the type and stage of disease the total WBC is usually  $30\text{--}100 \times 10^9/l$  and pleomorphic leukaemic lymphocytes with a multilobed nucleus may be found in the blood and bone marrow.

## MYELOMATOSIS

Myelomatosis is a monoclonal proliferation of plasma cells (myeloma cells) in bone marrow, arising from the malignant transformation of a B lymphocyte. The malignant plasma cells replace normal haematopoietic tissue, destroy bone (cytokine-mediated), and secrete monoclonal (single type) immunoglobulin, usually IgA or IgG, referred to as paraprotein. Most myelomas also produce Ig fragments (light chains or parts of heavy chains). Light chain fragments filter through kidney glomeruli and can be found in the urine (Bence Jones protein). Myelomatosis is typically found in the elderly. In developing countries the disease is also found in younger people (30–60 y).

### Clinical features of myelomatosis

The disease progresses slowly causing anaemia, bone pain (X-ray shows characteristic ‘punched out’ bone lesions), backache, fractures, renal disease, hypercalcaemia, hyperuricaemia, nerve damage, and recurrent bacterial infections due to low levels of normal Ig and neutropenia. Large amounts of paraprotein can cause increased plasma viscosity with risk of thrombosis, and neurological disorders. Haemorrhaging may occur due to paraprotein affecting coagulation and platelet function, and to thrombocytopenia.

### Laboratory findings in myelomatosis

- Normochromic normocytic anaemia is common.
- Thrombocytopenia and neutropenia are usually found in the late stages of disease. The total white cell count is low or normal.
- Markedly raised erythrocyte sedimentation rate (ESR), usually greater than 100 mm/h, due to the presence of paraprotein. The ESR may be low when there is hyperviscosity.
- *Blood film:* Romanowsky stained films appear more blue in colour than normal blood films. The paraprotein gives a pale blue stained background to films (absent when only Ig light chains are produced). Rouleaux of red cells is common due to paraproteinaemia. Plasma cells showing a typical eccentric cartwheel type nucleus may occasionally be seen (see colour Plate 93)

and some may appear abnormal (immature nucleus with nucleolus, multinucleate forms, and vacuolated cells). Occasionally a leukoerythroblastic blood picture may be seen. Bone marrow smears show increased numbers of plasma cells which may be atypical.

- *Serum electrophoresis:* Monoclonal Ig forms a distinct narrow band, i.e. M (monoclonal) band, usually in the *gamma* region. No M band is seen when only light chains are produced.

**Other causes of paraproteinaemia:** Besides myelomatosis, other conditions in which paraprotein is produced include Waldenström’s macroglobulinaemia, chronic lymphatic leukaemia, and B-cell lymphomas. Occasionally paraproteins are produced transiently in acute infections and connective tissue diseases.

- *Bence Jones protein* (light chains): May be detected in urine using a heat precipitation test\* but this test lacks sensitivity and specificity for myelomatosis diagnosis.

\*Cloudiness appears when urine is heated to 40–60 °C and re-dissolves when urine is heated further.

- Measurement of serum calcium is helpful in detecting hypercalcaemia and serum creatinine to screen for renal complications. Serum albumin levels are reduced and uric acid increased.

## Waldenström’s macroglobulinaemia

This slowly progressive condition is more common in men than women and involves the clonal proliferation of B lymphocytes. IgM paraprotein is produced and usually an excess of light chains. High levels of IgM paraprotein can lead to plasma viscosity which increases the risk of thrombosis and neurological complications. Bone disorders are rare.

*Note:* Haematological changes associated with HIV diseases are described in subunit 7.18.55.

---

## Infectious mononucleosis

Infectious mononucleosis (glandular fever) is an acute infectious viral disease characterized by fever, sore throat, malaise and lymphadenopathy. It is caused by primary infection with the human herpes virus, Epstein-Barr virus (HHV4). In tropical countries, EBV infection often occurs at an early age (below 3 y) and is usually asymptomatic. Infectious mononucleosis is therefore less common in tropical developing countries compared with other countries where the disease is mostly found in young adults due to primary infection with EBV occurring later in life.

*Laboratory features*

The main laboratory findings in infectious mononucleosis (IM) are:

- Leukocytosis with absolute lymphocytosis.
- Significant numbers of reactive (atypical) lymphocytes in the blood film (see colour Plate 94).
- Positive heterophile antibody test.

**Heterophile antibody test**

Heterophile antibodies are not directed against EBV antigens. They are antibodies (globulins) that react with antigens of another species. During infectious mononucleosis (IM), up to 98% of patients produce a special type of heterophil antibody that agglutinates sheep, horse, and bovine red cells.

Currently available slide tests to screen for IM heterophile antibody use reagents that have been made non-reactive to other heterophile antibodies, e.g. Forssman antibody and insensitive to serum sickness antibody. The test method involves mixing a drop of the patient's serum or plasma with a drop of the reagent which is usually specially treated dyed horse red cells or latex particles coated with purified glycoprotein from bovine red cells. Agglutination indicates that the patient's serum contains IM heterophile antibody. Positive and negative controls (included in test kits) are tested at the same time as the patient's sample.

*Note:* The heterophile antibody test may also be positive in other conditions including leukaemia, Burkitt's lymphoma, cytomegalovirus infection, and viral hepatitis.

**Availability of test kits to detect IM heterophilic antibody**

There are several manufacturers of test kits to screen for IM heterophile antibody. Plasmatec *IM Latex Test Kit* is available as a 50 test kit (code IM010) and 100 test kit (code IM/012). Contact details for Plasmatec can be found in Appendix 11.

**Systemic Lupus Erythematosus**

Systemic lupus erythematosus (SLE) is an autoimmune relapsing disease in which autoantibodies to nuclear proteins are produced, including anti-DNA antibodies. Immune complexes cause tissue damage. The features of the disease include arthritis, arthralgia, fever, malaise, typical facial 'butterfly' skin rash, cytopenias, and often also nephritis, cardiopulmonary and central nervous system complications. Genetic, viral, and environmental factors are thought to be involved in the development of SLE.

SLE is uncommon in most African tropical countries. It is found in South Africa, Southeast Asia, in people of African origin (living in the USA) and in other countries. Young women are more commonly affected.

*Laboratory features*

- Leukopenia (neutropenia and lymphopenia), thrombocytopenia, and usually anaemia.
- Occasionally circulating lupus anticoagulant is present which can cause prolonged prothrombin time and activated partial thromboplastin time (APTT).
- Presence of anti-deoxyribonuclear protein (anti-DNP) antibodies in active SLE which can be detected by a slide agglutination test using latex particles coated with

deoxynucleoprotein. An SLE latex test is available from several sources, including Remel Seradyn and HD Supplies.

*Note:* Immunological tests have now replaced the insensitive LE cell test in the investigation of SLE.

## FURTHER INFORMATION

**Fleming AF, de Silva PS.** Haematological diseases in the tropics, Ch 15 *Mansons Tropical Diseases*, 21st edition, 2003, Saunders, Elsevier.

**Crawley J.** Reducing the burden of anaemia in infants and young children in malaria-endemic countries of Africa: from evidence to action. *American Journal of Tropical Medicine Hygiene*, 71 (supp 2), pp. 25–34, 2004.

**Lewis DL et al.** Treatable factors associated with severe anaemia in adults admitted to medical wards in Blantyre, Malawi, an area of high HIV seroprevalence. *Transactions Royal Society Tropical Medicine & Hygiene*, 99, pp. 561–567, 2005.

**Weatherall DJ, Clegg JB.** Inherited haemoglobin disorders: an increasing global health problem. *Bulletin World Health Organization*, 79, (8), 2001.

**Stephens A.** Haemoglobinopathies, screening and diagnosis. *Biomedical Scientist*, Feb. 2005.

**Evatt BL et al.** *Fundamental diagnostic haematology – Anaemia*. World Health Organisation & US Dep Health & Human Services, CDC, 2nd edition, 1992. Available from WHO Publications, WHO, 1211 Geneva, 27-Switzerland.

**Lewis SM et al.** *Practical Haematology*, 9th edition, 2001. Churchill Livingstone, Elsevier.

## 8.3 Collection of blood

Blood must be collected with care and adequate safety precautions to ensure test results are reliable, contamination of the sample is avoided and infection from blood transmissible pathogens is prevented. Protective gloves should be worn when collecting and handling blood samples. Lancets, needles, and syringes must be sterile, and dry, and blood collecting materials must be discarded safely to avoid injury from needles and lancets.

*Note:* The safe use, decontamination, and disposal of blood contaminated materials and the preparation and use of hypochlorite solutions are described in subunit 3.4 in Part 1 of the book.

**Capillary blood**

Capillary blood is mainly used when the patient is an infant or young child and the volume of blood required is small, e.g. to measure haemoglobin, perform a WBC count, and to make thick and thin

blood films. In district laboratories, capillary blood is also used to monitor anaemia during pregnancy and post-operatively. Haemoglobin and PCV values are slightly higher in capillary blood than in venous blood. Thick blood films for malaria parasites are best made from capillary blood (anticoagulated blood is more easily washed from slides during staining).

**Importance of collecting thick and thin blood films from children:** When a haemoglobin test is requested, always collect both thin and thick blood films at the same time. If a child is found to be moderately or severely anaemic, the blood films can often indicate with the minimum of delay the cause(s) of the anaemia, e.g. malaria or sickle cell disease.

Disadvantages in using capillary blood for blood tests include:

- Capillary blood can be used for only a few tests\*.  
\*The suitability of capillary blood for a particular test is indicated in the subunits describing individual tests.
- Greater possibility of sampling errors particularly when the blood is not free-flowing, e.g. dilution of the sample with tissue juice can occur if the puncture area is squeezed excessively.
- Difficulty in obtaining sufficient blood particularly when it is required for more than one test. Rapid clotting of blood in a pipette is common, particularly in tropical temperatures.
- Tests cannot be repeated immediately or further tests performed when results are unexpected or seriously abnormal. A patient may have also received treatment following collection of the capillary sample, e.g. an antimalarial drug.
- It is not possible to estimate platelets in blood films made from capillary blood (platelets clump).

Capillary blood can be collected from:

- The 'ring' finger of a child or adult as shown in Fig. 8.1. Do not stick the thumb or index finger as these are the most sensitive.
- The heel of an infant up to one year old as shown in Fig. 8.2. Care must be taken not to damage the heel by sticking it too near the edge or by holding it too forcibly.

#### *Technique for collecting capillary blood*

Make sure the puncture area is warm to allow the blood to flow freely. On cold days soak the hand or foot of an infant in warm water prior to collecting a sample.

- 1 Cleanse the puncture area with 70% ethanol. Allow the area to dry.
- 2 Using a sterile pricker or lancet, make a rapid puncture, sufficiently deep to allow the free flow of blood.

- 3 Wipe away the first drop of blood with a dry piece of cotton wool and use the next few drops for the test. Do not squeeze too hard because this will result in an unreliable test result.
- 4 When sufficient blood has been collected, press a piece of dry cotton wool over the puncture area until bleeding stops.

*Note:* Mouth suction pipetting *must NOT* be used. Inexpensive devices for the safe pipetting and dispensing of capillary blood samples are described and illustrated in subunit 4.6 in Part 1 of the book. The technique of measuring blood accurately using a micropipette or calibrated capillary is illustrated in subunit 8.4.

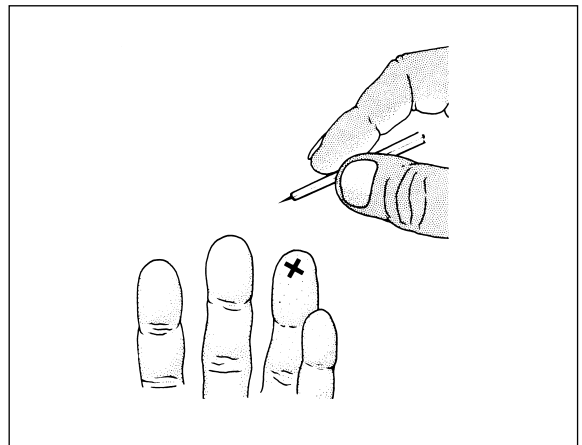

Fig 8.1 Collection of capillary blood from a finger.

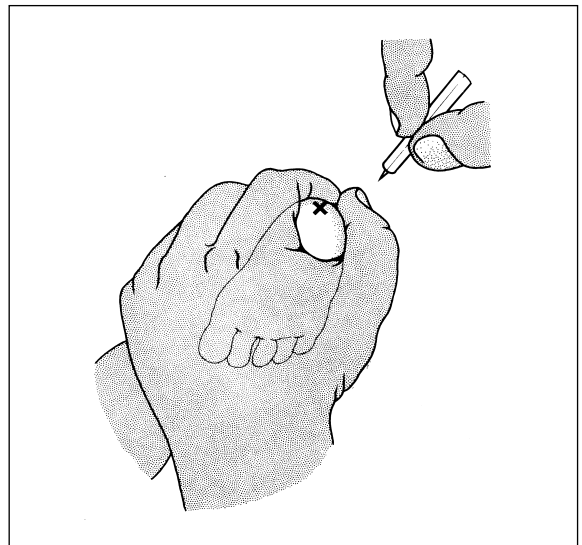

Fig 8.2 Collection of blood from the heel of an infant. The foot as outlined on the drawing is held in the hand.



### Venous blood

Anticoagulated venous blood is used when more than 100 µl of whole blood is required or when serum from a clotted blood sample is needed, e.g. for compatibility tests or antibody tests. Venous blood is preferable to capillary blood for the reasons previously described, particularly when the patient is an adult and several tests are required.

#### Anticoagulants

For haematological tests, the anticoagulants used are EDTA (ethylenediamine tetra-acetic acid), also called sequestrene, and *tri*-sodium citrate. These chemicals prevent blood from clotting by removing calcium.

- EDTA anticoagulated blood can be used for most tests, e.g. haemoglobin, PCV, WBC count, platelet count, reticulocyte count, and reporting blood cell morphology. It is not suitable for coagulation tests.

The ICSH (International Committee for Standardization in Haematology) recommends the use of dipotassium EDTA\* at a concentration of  $1.5 \pm 0.25$  mg/ml of blood (see Reagent No. 37).

#### \*Dipotassium EDTA

This is recommended in preference to disodium EDTA because it is more soluble.

*Importance of correct concentration of EDTA:* The correct amount of blood must be added to EDTA to prevent blood cell changes. Excess EDTA causes shrinkage and degenerative changes, e.g. amounts in excess of 2 mg/ml of blood can cause the disintegration of platelets, decrease in centrifuged PCV, and increase in MCHC. The blood must be well mixed with the EDTA.

- Trisodium citrate, 32 g/l, is used to anticoagulate blood for:
  - Measuring the ESR, with 1.6 ml of venous blood (or previously collected EDTA blood) being mixed with 0.4 ml of sodium citrate anticoagulant.
 

**Note:** ESR measurements are being discontinued in many tropical countries (see subunit 8.8)
  - Coagulation tests, with 9 ml of venous blood being mixed with 1 ml of sodium citrate anticoagulant.

**Heparin anticoagulant:** Heparinized blood is mainly used for clinical chemistry tests and immunophenotyping. It is not recommended for routine haematological tests because it causes cells to clump and heparin gives a blue background to blood films.

#### Technique for collecting venous blood

Laboratory staff must not collect venous blood unless they have been adequately trained in the pro-

cedure. Newly qualified staff must be supervised until they have gained sufficient experience. When venous blood is required from infants, this should be collected by a medical officer. Do not collect blood for haematological tests from intravenous lines.

- 1 Select a sterile, dry, preferably plastic syringe of the capacity required, e.g. 2.5 ml, 5 ml, or 10 ml. Attach to it a 19 or 20 SWG needle (preferably a disposable one). If the patient is a child or adult with small veins, use a 23 SWG needle.

*Note:* When not using a disposable syringe or needle, check the syringe for good suction and the needle for any blockage, directing the syringe and needle *safely away from the patient*. Ensure all air is expelled from the syringe. *Whenever possible use a disposable needle and syringe.*

**Evacuated tube collection systems:** These disposable blood collecting containers are available from several manufacturers but they are more expensive to use for collecting venous blood than a syringe and needle. The container has a vacuum which is used to draw the blood into the container. One end of the needle is situated in the patient's vein and the other end through the cap of the container. Evacuated collection systems minimize contact with blood, help to ensure the correct amount of blood is added to anticoagulant, and simplify multiple sample collection.

- 2 Apply a soft tubing tourniquet or velcro fastening arm band to the upper arm of the patient (see Fig. 8.3) to enable the veins to be seen *and felt*. Do not apply the tourniquet too tightly or for longer than 2 minutes. Ask the patient to make a tight fist which will make the veins more prominent.
- 3 Using the index finger, feel for a suitable vein, selecting a sufficiently large straight vein that does not roll and with a direction that can be felt\*.
 

\*If a vein cannot be felt, apply a pressure cuff above the elbow and raise the pressure to 80 mm (deflate the cuff once the needle is in the vein).
- 4 Cleanse the puncture site with 70% ethanol and allow to dry. Do not re-touch the cleansed area.
- 5 With the thumb of the left hand holding down the skin below the puncture site, make the venepuncture with the bevel of the needle directed upwards in the line of the vein. Steadily withdraw the plunger of the syringe at the speed it is taking the vein to fill\*. Avoid moving the needle in the vein.

\*If the plunger is withdrawn too quickly this can cause haemolysis of the blood and the collapse of a small vein.

- 6 When sufficient blood has been collected, release the tourniquet and instruct the patient to open his or her fist. Remove the needle and immediately press on the puncture site with a piece of dry cotton wool. Remove the tourniquet completely. Instruct the patient to continue pressing on the puncture site until the bleeding has stopped.
- 7 Remove the needle from the syringe and carefully fill the container(s) with the required volume of blood. Discard the needle safely. *Do not* attempt to re-sheath it because this can result in needle-stick injury.  
*Important:* Do not fill a container with the needle attached to the syringe. Forcing the blood through the needle can cause haemolysis.
- 8 Mix immediately the blood in an EDTA or citrate anticoagulated container. When required, make a thick blood film from the blood remaining in the syringe. Immediately label carefully all the blood samples.
- 9 Check that bleeding from the venepuncture site has stopped. Cover the area with a small dressing.

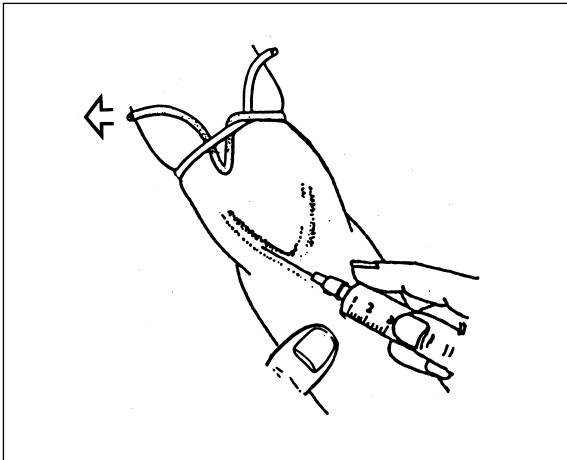

Fig 8.3 Collection of venous blood. After collecting blood, the tourniquet is released by pulling the tubing end on the left (marked with an arrow).

*Avoiding haematoma when collecting venous blood*  
Bleeding from a vein into the surrounding tissue (haematoma) can cause unnecessary distress to

a patient and result in subsequent bruising. Haematoma can be avoided by ensuring an appropriate vein is selected and the needle is well positioned in it and not accidentally pulled out of the vein when withdrawing the plunger of the syringe. When removing the needle, always release the tourniquet *first* and apply pressure immediately to the puncture site, maintaining it until the bleeding has stopped completely (*always* check).

#### *Avoiding haemolysis of blood samples*

Haemolysis can be avoided by:

- Checking that the syringe and needle are dry and that the barrel and plunger of the syringe fit well.
- Not using a needle with too fine a bore.
- Not withdrawing the blood too rapidly or moving the needle once it is in the vein. Frothing of the blood must be avoided.
- Removing the needle from the syringe before dispensing the blood into the specimen container and allowing the blood to run gently down the inside wall of the container.
- Adding the correct amount of blood to anticoagulant. Do not shake the blood but gently mix it with the anticoagulant.
- Using clean dry glass tubes or bottles for blood from which serum is required. Allow sufficient time for the blood to clot *and* clot retraction to take place. Red cells are very easily haemolyzed by the rough use of an applicator stick to dislodge a clot.
- Centrifuging blood samples for a minimum period of time. Centrifuging for 5 minutes at about 1000 g is adequate to obtain serum or plasma.
- Not storing whole blood samples in, or next to, the freezing compartment of a refrigerator.

#### **Stability of anticoagulated blood**

##### *EDTA anticoagulated blood*

When EDTA anticoagulated blood cannot be tested within 1–2 hours it must be refrigerated at 4–8 °C to prevent cellular changes affecting test results. Manual or automated blood cell counts, reticulocyte counts, and PCV change little in EDTA blood at 4–8 °C when stored for up to 24 hours. Haemoglobin concentration is stable for 2–3 days at 4–8 °C providing there is no haemolysis.

**Important:** Blood which has been refrigerated must be allowed to warm to room temperature and be *well mixed* before being tested.

*Blood films:* In EDTA anticoagulated blood, morphological blood cell changes occur soon after blood is collected when it is stored at room temperature (18–25 °C) and within 3 hours when stored at 4–8 °C. It is therefore recommended that blood films be made and methanol-fixed as soon as possible after blood is collected and never made after overnight storage. Some of the blood cell changes which occur in EDTA blood include:

- Neutrophil degeneration with neutrophils becoming more irregular in shape, nuclear lobes separating, and vacuoles appearing in the cytoplasm. There is also loss of granules.
- Segmentation (budding) of the nucleus of lymphocytes and monocytes and vacuoles appearing in the cytoplasm.
- Erythrocytes becoming crenated and spherocytic.
- Platelets disintegrating.

#### *Citrate anticoagulated blood*

Even when citrated blood is stored at 4–8 °C, there is a decrease in the ESR due to changes in erythrocyte shape affecting rouleaux. The ESR should be measured within 4 hours of collecting the blood. Coagulation tests should be carried out as soon as possible after blood is collected into citrate anticoagulant.

*Note:* The stability of biochemical substances in stored blood is covered in subunit 6.2 in Part 1 of the book.

*Errors associated with collecting blood for haematological tests:* These are summarized in subunit 8.1 (*Pre-analytical stage*).

## 8.4 Measurement of haemoglobin

**Value of test:** Haemoglobin is measured to detect anaemia and its severity and to monitor an anaemic patient's response to treatment. Monitoring the haemoglobin level (or PCV) is also required when patients with HIV disease are being treated with drugs such as AZT (see subunit 7.18.55). The test is also performed to check the haemoglobin level of a blood donor prior to donating blood.

*Note:* The importance of haemoglobin and the main causes of anaemia in tropical countries are described in subunit 8.2.

**Specimen:** Capillary blood or EDTA anticoagulated venous blood can be used. The collection of blood is described in subunit 8.3.

### Techniques for measuring haemoglobin and assessing anaemia

In district laboratories, depending on available facilities and resources, haemoglobin is measured photometrically or estimated using a visual comparative technique. Haemoglobin values are expressed in grams per litre (g/l) or grams per decilitre (g/dl)\*.

\*Grams/litre is the recommended way of expressing the mass concentration of haemoglobin. Some countries however continue to express haemoglobin in g/dl and most visual comparative techniques use g/dl.

#### *Photometric techniques*

In photometric techniques the absorbance of haemoglobin in a blood sample is measured electronically using a filter colorimeter or a direct read-out haemoglobin meter. Techniques include dilution techniques in which blood is measured into a measured volume of diluting fluid, and non-dilution techniques which do not require prior dilution of the blood.

### DILUTION TECHNIQUES

These include:

- Haemiglobincyanide (cyanmethaemoglobin) technique using a filter colorimeter or direct read-out meter. This technique is ICSH recommended because stable haemiglobincyanide (HiCN) standards are available to calibrate instruments. It has however, several disadvantages when used in tropical countries.
- Alkaline haematin D-575 technique using a filter colorimeter or direct read-out meter. It is as accurate as the haemiglobincyanide technique but less expensive and uses a diluting reagent that does not contain toxic potassium cyanide. A crystalline compound, chlorohaemin is used to calibrate the method (requires preparation in the Central or Regional Laboratory).
- Using a direct read-out meter such as the *Developing Health Technology (DHT) Haemoglobinometer* which is a haemoglobin meter with specifications and technique suitable for use in district laboratories in tropical countries.

## NON-DILUTION TECHNIQUES

Blood is collected directly into a specially designed single-use microcuvette or other sampling device which is internally coated with reagent to lyse the blood and convert the haemoglobin to a form which can be read in a direct read-out meter. While the cost of direct read-out meters for use with non-dilution systems is becoming less, the cost of the sampling devices remains high compared with most dilution systems, particularly the DHT Haemoglobin system.

### *HemoCue system*

This non-dilution system is becoming more widely used in tropical countries because of the lower cost of the new haemoglobin meter, its accuracy, and simplicity of use. It is described and illustrated at the end of the dilution techniques. It is particularly useful when a dilution technique cannot be used, e.g. in a clinic with nursing staff performing haemoglobin tests.

### *Visual comparative technique*

When it is not possible to measure haemoglobin accurately using a photometric technique, e.g. in a health centre or antenatal unit, a visual comparative technique such as the *Haemoglobin Colour Scale*, can help to detect anaemia and assess its severity.

**BMS haemoglobin meter (comparator):** This is no longer manufactured.

## HAEMIGLOBINCYANIDE (HiCN) TECHNIQUE

### **Principle of test**

Whole blood is diluted 1 in 201 in a modified Drabkin's solution which contains potassium ferricyanide and potassium cyanide. The red cells are haemolyzed and the haemoglobin is oxidized by the ferricyanide to methaemoglobin. This is converted by the cyanide to stable haemiglobincyanide (HiCN). Absorbance of the HiCN solution is read in a spectrophotometer at wavelength 540 nm or in a filter colorimeter using a yellow-green filter. The absorbance obtained is compared with that of a reference HiCN standard solution. Haemoglobin values are obtained from tables prepared from a calibration graph or if using a direct read-out haemoglobin meter, from the digital display.

### **Diluting fluid and standards**

- Drabkin's neutral diluting fluid, pH 7.0–7.4

This fluid contains:

Potassium ferricyanide (hexacyanoferrate 111) . . . 200 mg  
 Potassium cyanide\* . . . . . 50 mg  
 Potassium dihydrogen phosphate . . . . . 140 mg  
 Non-ionic detergent (e.g. Nonidet, Triton-X-100) . . . 1 ml  
 Distilled or deionized water. . . . . to 1 litre

\*Potassium cyanide is highly poisonous. It *must* be stored securely in a locked cupboard. Because of the hazard associated with the storage and use of this chemical and

often the difficulty in obtaining it and other chemicals in Drabkin's fluid, many laboratories buy Drabkin's fluid in a ready-prepared form to which water is added. It is also possible to purchase cyanide-free diluting fluids for use in the HiCN technique, but these are not as widely available.

**Availability of neutral Drabkin's fluid concentrate:** An example of a supplier is Diagnostic Reagents Ltd (see Appendix 11). Each pack contains 6 × 25 ml bottles. Each bottle of concentrate makes 1 litre of diluting fluid.

*Important:* Drabkin's fluid must be stored in a light opaque container, e.g. brown glass bottle or ordinary glass bottle wrapped in silver foil. It is a pale yellow *clear* fluid and must not be used if it loses its colour or becomes turbid (see later text *Quality Control*).

- Haemiglobincyanide (cyanmethaemoglobin) standard

This is needed to calibrate a filter colorimeter. HiCN solutions are stable for long periods (2 years or longer). Haemiglobincyanide (HiCN) reference standard solutions are available as:

- Ready to use diluted haemiglobincyanide (cyanmethaemoglobin) standards\* equivalent to haemoglobin values:

30 g/l (3.0 g/dl)  
 115 g/l (11.5 g/dl)  
 180 g/l (18.0 g/dl)

\*The diluted HiCN solutions are suitable for preparing a calibration graph for use in obtaining patients' haemoglobin values using 20 µl blood and 4 ml Drabkin's diluting fluid, i.e. 1 in 201 dilution, (see Method A in following text).

### **Availability of diluted haemiglobincyanide standards:**

A supplier of ready to use HiCN standards equivalent to 30 g/l, 115 g/l, 180 g/l is Diagnostics Reagents Ltd (see Appendix 11). A pack of 6 sets contains in each set 25 ml of each standard. The standards must be stored at 4–8°C. They have a shelf-life of 2 years.

- Haemiglobincyanide (cyanmethaemoglobin) standard solution conforming to BS 3985 with HiCN concentration varying between 550–850 mg/l (55–85 mg%). The actual value will be printed on the label of each ampoule. From this, the equivalent haemoglobin value needs to be determined.

*Note:* Preparing a calibration graph from this HiCN reference standard is more complex than when using the previously described ready to use HiCN standards (see following text, Method B).

### **Availability of haemiglobincyanide standard BS 3985:**

A pack of 25–10 ml ampoules of HiCN (cyanmethaemoglobin) standard, BS 3985, is available from Merck/BDH (see Appendix 11).

**Preparing a calibration graph**

*Method A: Using ready to use HiCN standards 30 g/l, 115 g/l, 180 g/l*

- 1 Allow the standards to warm to room temperature.
- 2 Place a yellow-green filter (e.g. Ilford 605, Wratten 74, Chance 0Gr 1) in the colorimeter or set the wavelength to read 540 nm.
- 3 Zero the colorimeter with Drabkin's neutral diluting fluid.
- 4 Read the absorbance of each standard, beginning with the lowest.
- 5 Take a sheet of graph paper and plot the absorbance of each standard (vertical axis) against its concentration in g/l (horizontal axis).
- 6 Draw a straight line from zero through the points plotted. Extend the line to obtain readings up to 200 g/l (20 g/dl).
- 7 From the graph, make a table for Hb values from 20–200 g/l (2–20 g/dl).

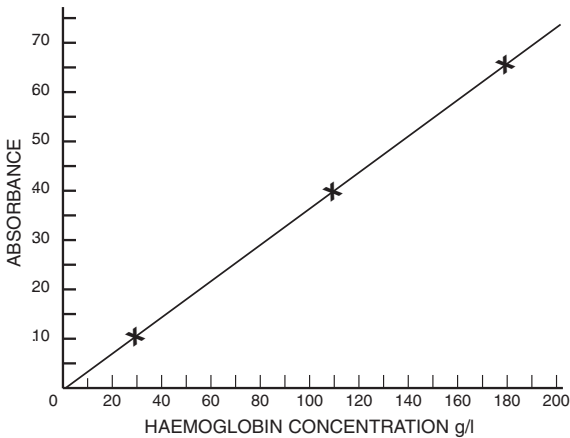

Fig 8.4 Example of an HiCN haemoglobin calibration graph using commercially produced HiCN standards: 30g/l, 115g/l, 180g/l (see text).

*Method B: Using HiCN standard solution, BS 3985*

- 1 Calculate the haemoglobin (Hb) equivalent value of the HiCN standard in grams/litre:

$$\text{Concentration HiCN in mg/l}^* \times \frac{200}{1000}$$

(as on printed label)

\*If written in mg%, multiply figure by 10 to give mg/l.

*Example:* If HiCN concentration on label is 600 mg/l (60 mg%):

$$\frac{600 \times 200}{1000} = \text{Hb } 120 \text{ g/l (12.0 g/dl)}$$

- 2 Take 6 tubes and label them B (Blank), 1, 2, 3, 4, 5.
- 3 Pipette into each tube as follows:

Tube	B	1	2	3	4	5
ml HiCN standard	–	4	3	2	1	5
ml Drabkin's fluid	5	1	2	3	4	–

Stopper each tube and mix.

- 4 Place a yellow-green filter in the colorimeter or set the wavelength at 540 nm.
- 5 Zero the colorimeter using the Drabkin's neutral fluid in tube B.
- 6 Read the absorbances.
- 7 Calculate the haemoglobin (Hb) equivalent in g/l of solutions in tubes 1–5 as follows:

**Tube 1:** Hb value of HiCN standard\*  $\times \frac{4}{5} = \dots$  Hbg/l  
 (\*This is the value obtained in step 1)

**Tube 2:** Hb value of HiCN standard  $\times \frac{3}{5} = \dots$  Hbg/l

**Tube 3:** Hb value of HiCN standard  $\times \frac{2}{5} = \dots$  Hbg/l

**Tube 4:** (Hb value of HiCN standard  $\times \frac{1}{5} = \dots$  Hbg/l

**Tube 5:** Hb value of HiCN standard (undiluted HiCN standard) =  $\dots$  Hbg/l

- 8 Proceed as described in steps 5–7 of the previous calibration method.

**HiCN Test method**

- 1 Measure carefully 20 µl (0.02 ml) of capillary blood\* or *well-mixed* venous blood\* and dispense it into 4 ml Drabkin's neutral diluting fluid.

\*The collection of capillary blood and venous blood are described in subunit 8.3.

*Important:* The volume of blood used in the test must be exactly 20 µl.

**Accurate and safe pipetting and dispensing:** Pipettes, calibrated capillaries and suction devices for the accurate and safe measuring and dispensing of blood and diluting fluid are described and illustrated in subunit 4.6 in Part 1 of the book.

- 2 Stopper the tube, mix, and leave the diluted blood at room temperature, protected from sunlight, for 4–5 minutes\*

\*This time is adequate for conversion of haemoglobin to HiCN when using a *neutral* (pH 7.0–7.4) Drabkin's reagent. Up to 20 minutes is required when using an alkaline Drabkin's reagent.

- 3 Place a yellow-green filter (e.g. Ilford 605) in the colorimeter or set the wavelength at 540 nm.
- 4 Zero the colorimeter with Drabkin's fluid and read the absorbance of the patient's sample.
- 5 Using the table prepared from the calibration graph, read off the patient's haemoglobin value.

*Interpretation of test results:* See end of this subunit.

#### Technique for measuring blood accurately

- 1 Draw free-flowing capillary blood or *well-mixed* anticoagulated venous blood to the 20 $\mu$ l \* mark of a micropipette or calibrated capillary.

\*Some micropipettes are marked 0.02ml or 20cmm. These volumes are the same as 20 $\mu$ l.

- 2 Wipe the blood from around the tip of the pipette. To do this without withdrawing blood from the pipette, draw the blood further up the pipette, out of the tip.

- 3 Return the blood to the mark. Re-check the blood is still on the 20 $\mu$ l mark before dispensing it.

- 4 Dispense the blood into the diluting fluid at the bottom of the tube. Rinse the pipette in the diluting fluid.

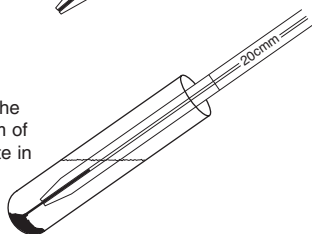
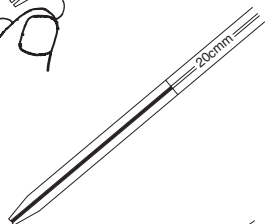
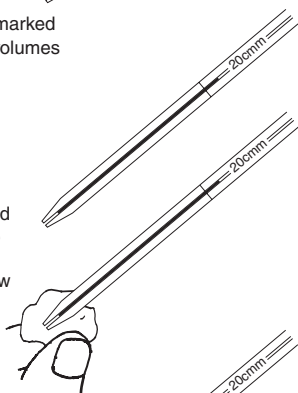
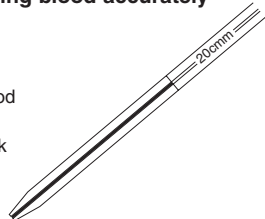

#### Quality control of HiCN technique

For the daily control of haemoglobin tests, district laboratories should be provided with a preserved whole blood control or a stable control haemolysate prepared and analyzed in the Regional or Central Hospital Laboratory.

*Note:* Instructions on how to prepare a control haemolysate and stable whole blood control can be found in the WHO document *Quality Assurance in Haematology*, WHO/LAB/98.4 (see end of subunit 8.1).

The control haemolysate should be used each day to ensure the colorimeter or haemoglobin meter is functioning satisfactorily, and Drabkin's diluting fluid has not deteriorated. A quality control chart should be prepared and the haemoglobin values of the control haemolysate entered daily on the chart as described for clinical chemistry quantitative tests on pp. 325–328 in Part 1 of the book. This will detect any drift of values upwards or downwards indicating that the results of haemoglobin tests are becoming unreliable, and there is a problem which must be investigated.

When a control haemolysate or preserved whole blood control is not available, the minimum control of haemoglobin tests using the HiCN technique must include:

- Daily use of a HiCN reference standard (as used to calibrate the colorimeter) to check instrument performance.
- Visible and photometric check of Drabkin's diluting fluid for signs of deterioration, particularly turbidity which is a common problem in tropical countries. When measured against a water blank with a yellow-green filter in place (wavelength 540 nm), Drabkin's fluid should give a zero reading. The pH of the fluid should be pH 7.0–7.4. If deterioration is indicated, the fluid should not be used. Fresh Drabkin's reagent must be prepared. During the 'hot' season, Drabkin's fluid is best stored refrigerated. It must be allowed to warm to room temperature before being used.

#### ALKALIN HAEMATIN D (AHD) TECHNIQUE

##### Principle of test

Whole blood is diluted 1 in 151 in a non-ionic, alkaline detergent diluting fluid (AHD reagent) which contains sodium hydroxide and Triton X-100 (or equivalent). The red cells are haemolyzed and the haemoglobin is converted to alkaline haematin D-575 which is a stable coloured compound. Absorbance of the alkaline haematin D-575 solution is measured in a spectrophotometer at wavelength 540 nm or in a filter colorimeter using a yellow-green filter. The absorbance

obtained is compared with that of a stable AHD chlorohaematin standard (requires preparation in Regional or Central Laboratory). Haemoglobin values are obtained from tables prepared from a calibration graph or if using a direct read-out haemoglobin meter, from the digital display.

#### Test method

In the AHD technique, 20  $\mu$ l blood is diluted in 3 ml AHD diluting fluid. The alkaline haematin solution formed is measured after 2–3 minutes at wavelength 540 nm.

Full details of calibration and test method can be found in WHO *Manual of Basic Techniques for a Health Laboratory*, 2nd edition, 2003, World Health Organization, Geneva.

*Note:* The AHD method for measuring haemoglobin has been evaluated in seven laboratories (two in East Africa, three in East Mediterranean countries, two in Europe). The study demonstrated the value of the method for measuring haemoglobin at all levels.\*

\*Heuck CC *et al.* International collaborative assessment study of the AHD<sub>575</sub> method for the measurement of blood haemoglobin (in press, *Eastern Mediterranean Health Journal*).

### DHT 523 HAEMOGLOBINOMETER (Direct read-out Hb meter)

This modern electronic direct read-out haemoglobin meter is precalibrated by the manufacturer and therefore requires no calibration standard solutions. A glass control standard is provided for checking the performance of the meter.

#### Suitability for use in tropical countries

The DHT Haemoglobinometer uses an inexpensive diluting fluid which is simple to make (no weighing of chemicals) and is stable in tropical climates. The DHT meter measures all forms of haemoglobin (HbO<sub>2</sub>, HbCO, Hi, SHb) by measuring at a wavelength of 523 nm, using a narrow band (10 nm) interference filter and green light emitting diode (LED). Haemoglobin values are digitally displayed in g/l. The measuring range of the meter is 20–300 g/l.

The DHT Haemoglobinometer is particularly easy to use. The user simply inserts the cuvette and removes it. Placing the cuvette in the cuvette holder automatically turns on the electronic circuitry. In between measurements the meter returns automatically to a standby mode.

The meter requires very little electrical power to measure samples and to maintain the meter in its standby mode. The meter can be operated from mains electricity (220 V 50 Hz) using the 5 V AC/DC adaptor (optional) or from three AA longlife

alkaline leak-proof batteries (supplied). It has been estimated that several hundred thousand measurements can be made from one set of three alkaline batteries.

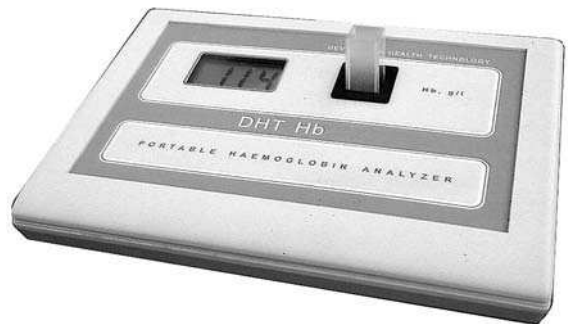

Plate 8.1 DHT 523 Haemoglobin Meter.  
Courtesy of Developing Health Technology.

The cuvettes used in the meter are standard size 10 mm light-path cuvettes (glass or plastic). The dimensions of the meter are: 178 mm wide  $\times$  127 mm deep  $\times$  43 mm high. It weighs approximately 300 g (without batteries). It is a sealed unit and the cuvette opening is fitted with a shutter to prevent dust entering when the meter is not being used.

#### Diluting fluid

Weak 0.4 ml/l (0.04%) ammonia Reagent No. 12 water

The reagent is stable when kept in a tightly stoppered bottle. Renew every 6 weeks.

*Note:* Weak ammonia water lyses red cells rapidly, is stable, and the ammonia solution used in its preparation is easily available and inexpensive. It does not require refrigeration. The test requires only 2 ml of ammonia diluting fluid.

#### Principle of operation

Light emitted from the LED passes through the blood sample and then through the interference filter, restricting the wavelength to peak at 523 nm within a narrow band. Light passing through this narrow band filter falls on the photodiode (see Fig. 8.5). This converts it to an electrical signal for the control and measurement system to calculate and display directly as a haemoglobin concentration in g/l. The meter has a stated photometry precision of  $<\pm 5\%$  (CV) and 2% accuracy of method. The meter must not be placed in direct sunlight and the operating environment should be within a temperature range of 10–35  $^{\circ}$ C with an upper humidity limit of 80% non-condensing.

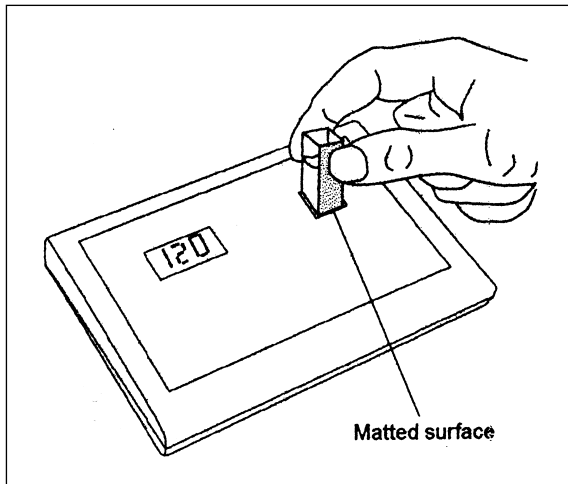
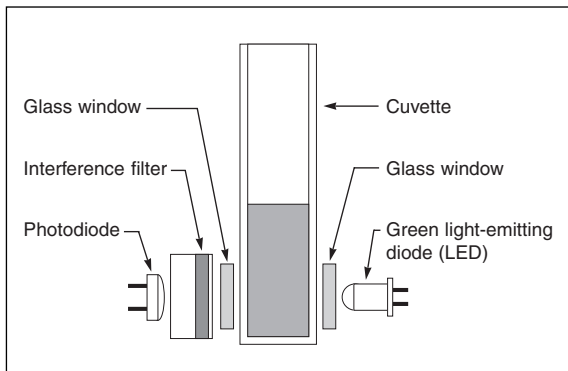

Fig 8.5 Upper: Placing a cuvette in the DHT Haemoglobin Meter. Lower: Principle of operation of the DHT 523 Haemoglobin Meter.

Courtesy of Developing Health Technology.



### Test method

- 1 Measure carefully 20  $\mu$ l (0.02 ml, 20 cmm) of capillary blood\* or well-mixed venous blood\* and dispense it into 2 ml of the ammonia diluting fluid.

\*The collection of capillary blood and venous blood are described in subunit 8.3.

**Important:** The volume of blood used must be exactly 20  $\mu$ l.

**Accurate and safe pipetting and dispensing:** Pipettes, calibrated capillaries, and suction devices for the accurate and safe measuring and dispensing of blood and diluting fluid are described and illustrated in subunit 4.6 in Part 1 of the book.

- 2 Stopper the tube and mix. The solution can be read immediately. The colour is stable for 6–8 hours.

- 3 Check the performance of the meter by inserting the *Control Standard* glass provided in the cuvette aperture. The reading must correspond to the stated value,  $\pm 5$ .

*Note:* Inserting a cuvette starts the measuring process. There is an audible signal as the meter reads the *Control Standard* or patient's sample. Immediately the value is shown on the digital display and held in memory for 30 seconds after the cuvette is removed. The last reading can be recalled by pressing a membrane key on the instrument. The *DHT Haemoglobinometer* has automatic zeroing. In between readings the meter remains in a standby mode.

- 4 Transfer the patient's sample or control blood sample to a clean 10 mm light-path cuvette. Hold the cuvette only by its non-optical sides and ensure there are no air-bubbles in the sample.
- 5 Place the cuvette in the cuvette holder, wait for the audible signal, and read the haemoglobin value from the display.
- 6 Return the sample to its tube and allow the cuvette to drain, e.g. invert it on a paper towel.

**Availability:** The *DHT 523 Haemoglobinometer* is available from Developing Health Technology (see Appendix 11). It is supplied with a set of batteries, several cuvettes, and the control glass standard.

*Interpretation of test results:* See end of this subunit.

### Sources of error when measuring haemoglobin photometrically

The following are the most important and commonest errors that can lead to unreliable test results when measuring haemoglobin photometrically:

- Not measuring the correct volume of blood due to poor technique or using a wet or chipped pipette.
- When using anticoagulated venous blood, not mixing the sample sufficiently.
- Not ensuring that the optical surfaces of a cuvette are clean and dry and there are no air bubbles in the solution.

#### *Technique to prevent cuvette-related errors*

- 1 Hold a clean cuvette only by its frosted (matt) or ridged sides. When transferring a solution to a cuvette, allow the fluid to run down the



inside wall of the cuvette. This will help to avoid air bubbles in the solution. Do not fill a cuvette more than three quarters full.

- Using a tissue or soft clean cloth, wipe clean the clear optical surfaces of the cuvette. Carefully insert the cuvette in the colorimeter or haemoglobin meter (optical surfaces facing the light source).

*Note:* Ensure a solution is at room temperature before reading its absorbance otherwise condensation will form on the outside of the cuvette which will give an incorrect reading.

- Not protecting a colorimeter or haemoglobin meter from direct sunlight and not checking the performance of an instrument or maintaining it as instructed by the manufacturer. A common error when using a filter colorimeter is using a glass filter which is not clean.
- Not checking a diluting fluid such as Drabkin's for signs of deterioration as explained in the HiCN technique.

### HEMOCUE HAEMOGLOBIN TECHNIQUE

The most recently developed *HemoCue* haemoglobin meter is the model 201<sup>+</sup>. It differs from previous models in being smaller, having an internal performance check system (control cuvette is no longer needed), and a new cuvette holder which prevents contamination of the optronic unit and is easier to clean. The 201<sup>+</sup> meter can also store up to 600 test results. The microcuvettes are specially designed for use with the model 201<sup>+</sup> (cannot be used in previous *HemoCue* models). They are individually packaged and available in a smaller pack size (25 per pack). While the new model 201<sup>+</sup> *HemoCue* is less expensive, the price of the microcuvettes remains high\*

\*Discount rates are available for bulk purchases and committed purchases.

The 201<sup>+</sup> *HemoCue* meter measures 85 × 160 × 43 mm and weighs 350 g (batteries included). It can be operated from mains electricity using the mains adapter supplied or from four AA batteries (not provided).

#### Principle of HemoCue

Undiluted whole blood is drawn into a chemically coated single-use microcuvette. The red cells are lysed by sodium deoxycholate and the haemoglobin reacts with sodium nitrite (forming methaemoglobin) and sodium azide to give azidemethaemoglobin which is measured by the meter at wavelengths 570 nm and also at 880 nm to compensate for any

turbidity in the sample, e.g. caused by high WBC count or raised lipids. The concentration of haemoglobin is digitally displayed in grams per litre or if preferred, g/dl. The measuring range of the *HemoCue* meter is 0–256 g/l (25.6 g/dl) with an accuracy of ±1.5% compared with the ICSH method. There is no interference from bilirubin.

The meter is calibrated by the manufacturer. A performance check (*self-test*) is built into the meter. Every time the meter is turned on (and every 2 hours during operation), a performance check is carried out. The operating environment should be within the temperature range 18–30°C with an upper humidity limit of 90% non-condensing.

#### Test method

- Pull out the microcuvette holder to its loading position.
- Press and hold down the left button of the meter until the display is activated. The meter automatically carries out a performance check. After 10 seconds the meter will show three flashing dashes, indicating it is ready for use.
- Fill a microcuvette in one continuous process with capillary blood or *well mixed* venous blood. \*Do not refill.

\*The collection of capillary blood and venous blood are described in subunit 8.3

*Note:* Should air bubbles form, another microcuvette must be used with a new blood sample.



*HemoCue* haemoglobin meter 201 showing microcuvette in loading position. Courtesy *HemoCue AB*.

- 4 Wipe off excess blood from the outside of the microcuvette tip, making sure no blood is withdrawn.
- 5 Within 10 minutes of filling the microcuvette, measure the haemoglobin. Place the microcuvette in the microcuvette holder and push in the holder to its measuring position. After 15–60 seconds, the haemoglobin value will be displayed (it will remain displayed for as long as the holder is left in its measuring position).

*Stability of microcuvettes in tropical countries:* The chemicals in the microcuvettes are hygroscopic. In tropical climates it is important to protect the microcuvettes from heat and particularly humidity. The container in which the microcuvettes are stored must be kept tightly capped. It is best to purchase the microcuvettes in pack sizes of 25, not 50. In humid climates, microcuvettes should be used within a few days of opening the storage container.<sup>1</sup>

**Availability:** The *HemoCue 201+* meter and microcuvettes are available from HemoCue AB in Sweden (see Appendix 11) and distributors (nearest distributor can be found by e-mailing HemoCue, info@hemocue.se)

### Haemoglobin Colour Scale

(see colour Plate 95)

This technique for estimating haemoglobin is based on comparing the colour of a drop of blood absorbed on a particular type of chromatography paper, against a printed scale of colours corresponding to six different levels of haemoglobin: 4, 6, 8, 10, 12, and 14 g/dl (intermediate readings can be made between any two adjacent shades of colour). Although similar in principle to the obsolete Tallqvist blotting paper method (discredited due to inaccuracy and imprecision) the new *Haemoglobin Colour Scale* uses modern materials and techniques to provide a simple, inexpensive, method for estimating haemoglobin in community health care where photometric measurement is not possible.<sup>2</sup> Lewis advises, that the Colour Scale is intended as a clinical device for the clinician/health worker at point-of-care so that it is possible to identify anaemia and judge its severity in the following clinical categories:

Hb > 12 g/dl	Not anaemic
Hb 10–11 g/dl	Mild anaemia
Hb 8–9 g/dl	Moderate anaemia
Hb 6–7 g/dl	Marked anaemia
Hb 4–5 g/dl	Severe anaemia
Hb < 4 g/dl	Critical

### Development of Haemoglobin Colour Scale

In developing the *Haemoglobin Colour Scale*, Stott and Lewis first identified the factors responsible for the wide margin of error associated with previous printed haemoglobin colour scales and testing methods (see *Further Reading*). These factors were related to the test paper used, calibration and materials used to produce the colour scale, and the lighting and other factors associated with colour matching of the blood sample.

The new *Haemoglobin Colour Scale* successfully overcomes the problems associated with previous printed colour scale devices by:

- Using as the test paper, a chromatography paper that ensures even, limited spread of the blood with constant drying. Stott and Lewis identified Whatman 31 ET Chr paper as giving the best results, and Schleicher and Schuell paper 2992 as second best.
- Using computerized spectrophotometry to identify the colours produced by blood from a set of haemoglobin standards. Light-resistant printing ink, densitometer controlled colour printing, and specialist paper (chemically neutral, chlorine-free) are used to print the specified colours to avoid fading of the colours and ageing (yellowing) of the paper. The *Colour Scale* is protected by a defined thin layer of varnish.
- Mounting the scale on a neutral grey background to avoid interference from reflected light.
- Identifying the best lighting conditions and method of comparing the colour of blood samples with the *Colour Scale*, i.e. use of daylight (not bright sunlight) coming from behind with the *Colour Scale* held at an angle of 45° and the test paper held close to the apertures of the Scale (with blood filling completely the viewing aperture).
- Identifying the optimum time to match the colour of the blood sample with the *Colour Scale* i.e. matching 1 minute after applying the blood and completing the reading within 2 minutes.

Exact details of how to estimate haemoglobin using the *Haemoglobin Colour Scale* are supplied with the Scale. From the above information it is clear that to obtain reliable test results it is *essential* to use only the special test papers supplied and *follow exactly* the instructions given for collecting a blood sample, amount of blood to use, and how to compare the colour of the blood with the colour standards of the *Colour Scale*.

**Availability of the Haemoglobin Colour Scale:** For details of ordering, readers should contact Copack GmbH, Am Knick 9, 22113 Oststeinbek, Germany. E-mail info@copackservice.de

### Assessment of the Haemoglobin Colour Scale

Overall the *Haemoglobin Colour Scale* is more reliable than clinical examination alone in diagnosing anaemia. In 2004, the Essential Health Technology Department of WHO reviewed the usefulness of the Colour Scale in various clinical situations and recommended ongoing studies on

the performance of the *Colour Scale* by health workers in the field.\*

\*The WHO Review of the *Haemoglobin Colour Scale*, WHO/EHT/04.02 can be obtained from Dept Essential Health Technologies, WHO. E-mail eht@who.int or from website www.who.int/eht

#### Sahli acid haematin method

This visual comparative method of estimating haemoglobin although still used in some health centres and hospitals is not recommended because of its unacceptable imprecision and inaccuracy. In the Sahli method, 20 µl of blood is mixed in a tube containing 0.1 mol/l hydrochloric acid (HCl) which converts the haemoglobin to acid haematin. After 10 minutes (or more), 0.1 mol/l HCl is added drop by drop, with mixing, until the colour of the solution matches the colour of the glass standard positioned alongside the dilution tube. The concentration of haemoglobin is read from the graduated scale on the dilution tube.

Most of the problems associated with the Sahli method are due to the instability of acid haematin, fading of the colour glass standard and difficulty in matching it to the acid haematin solution. Conversion to acid haematin is slow. HbF is not converted to acid haematin and therefore the Sahli method is not suitable for measuring haemoglobin levels in infants up to 3 months.

**Lovibond dilution method:** In this visual comparator method, blood is diluted in ammonia water or Drabkins reagent and compared with a series of coloured glass standards on a disc(s) equivalent to known haemoglobin values. In evaluations the method has been shown to have low accuracy. In a study in Malawi, only 37% of Lovibond haemoglobin test results were found to be of acceptable quality.<sup>3</sup>

#### Interpretation of haemoglobin test results

Normal haemoglobin levels vary according to age and gender, and the altitude at which a person lives.

#### Normal haemoglobin reference range (guideline figures)

Children at birth	135–195 g/l*
Children 2 y–5 y	110–140 g/l*
Children 6 y–12 y	115–155 g/l*
Adult men	130–180 g/l*
Adult women	120–150 g/l*
(Pregnant women)	110–138 g/l*

\*To convert to g/dl, divide by 10, e.g. 136–196 g/l is 13.6–19.6 g/dl.

Figures are taken from *Practical Haematology*, 8th edition, 1994. Churchill Livingstone.

#### Investigation of anaemia in district laboratories

Anaemia occurs when the concentration of haemoglobin falls below what is normal for a person's age, gender, and environment. Based on the common causes of anaemia in tropical countries (see subunit 8.2) the following are the preliminary investigations

which most district laboratories should be able to perform to investigate moderate anaemia (70–100 g/l) and severe anaemia (values below 70 g/l).

- Examination of a well made and well stained thin blood film to look for:
  - Erythrocyte abnormalities associated with anaemia, including: microcytic hypochromic cells, 'pencil' cells, polychromasia, macrocytes, megaloblasts, sickle cells, nucleated red cells, target cells, spherocytes, red cell fragments (see end of subunit 8.7).
  - Leukocyte changes, particularly increases and decreases in the absolute numbers of different leukocytes, pancytopenia, left shift of neutrophils with possible toxic granulation, presence of reactive (atypical) lymphocytes, and hypersegmented neutrophils. If indicated, perform a total white cell count (see subunit 8.6).
  - Platelet changes (if venous blood sample).
- Visual inspection of serum or plasma for increased yellow colour due to bilirubinaemia, indicating haemolytic anaemia. In iron deficiency the plasma appears colourless.
- Examination of a thick blood film for malaria parasites and malaria pigment, and when indicated, for trypanosomes (see subunits 5.7 and 5.8 in Part 1 of the book).
- Calculation of MCHC which will be low in iron deficiency anaemia (see subunit 8.5).
- Calculation of MCV (when an electronic blood cell analyzer is available to count red cells) to assist in the diagnosis of microcytic and macrocytic anaemias (see subunit 8.5).
- Tests to detect HbS, when sickle cell disease is indicated from the blood film or suspected clinically (see subunit 8.10).
- Reticulocyte count (see subunit 8.9) to assess erythropoietic response, particularly in the investigation of haemolytic anaemia.
- Platelet count (see subunit 8.6) when thrombocytopenia is suspected, e.g. in HIV/AIDS, dengue haemorrhagic fever, and bleeding disorders.
- WBC count (see subunit 8.6) to investigate con-

**Chart 8.5 Preliminary laboratory findings of common anaemias in tropical countries**

<i>Anaemia</i> <b>Iron deficiency</b>	<i>Blood film</i> Microcytic hypochromic red cells with 'pencil' cells See colour Plate 98	<i>Other tests</i> ● MCHC: ↓ Below 320 g/l ● MCV: ↓ Below 78 fl ● Reticulocytes: Normal or ↓ <i>Further tests:</i> Indicated if patient does not respond to treatment. See subunit 8.2.
<b>Macrocytic anaemia</b>		
● Folate deficiency (megaloblastic)	Macrocytes (mostly oval), occasional megaloblast, pancytopenia (late stages), hypersegmented neutrophils. See colour Plate 97	● MCV: ↑ More than 100 fl ● Reticulocytes: Normal or ↓ ● WBC and platelets: ↓ ● MCHC: Normal
● Liver disease (non-megaloblastic)	Macrocytes (mainly round), with target cells	<i>Further tests:</i> Examination of bone marrow smears. See also subunit 8.2. As above
<b>Sickle cell disease</b> B <sup>S</sup> /B <sup>S</sup> , Hb SC, HbS thalassaemia	Sickle cells, polychromasia, poikilocytosis, nucleated red cells, target cells. Macrocytes due to folate deficiency (when patient not receiving folate) See colour Plate 99	● Tests to detect HbS: Positive ● Reticulocytes: ↑ (blue stippling in background of thick film)  <i>Further test:</i> Hb electrophoresis. See subunit 8.10 and also subunit 8.2.
<b>Malaria (falciparum)</b>	Normocytic normochromic red cells. Often reactive (atypical) lymphocytes seen. Malaria parasites in red cells. See colour Plates 115 and 116	● Thick blood film: Malaria parasites present and often malaria pigment in WBCs. See subunit 5.7 in Part 1 of the book.
<b>G6PD deficiency</b> Haemolytic crisis	Spherocytes, polychromasia, 'bite' and 'ghost' cells See colour Plate 107	● Reticulocytes: ↑ ● Heinz bodies in red cells <i>Further test:</i> G6PD screening test (after crisis). See subunit 8.9.
<b>Associated with Septicaemia</b> e.g. due to <i>C. perfringens</i>	Spherocytes, polychromasia, nucleated red cells. Left shift of neutrophils with toxic granulation. See colour Plates 109 and 86	● WBC count: ↑ or ↓ See also subunits 8.6, 8.7.
<b>β thalassaemia major and intermedia</b>	Poikilocytosis, anisocytosis, target cells, hypochromic cells, nucleated red cells, basophilic stippling, red cell fragments See colour Plate 105	● MCV, MCHC: ↓ ● Reticulocytes: Normal <i>Further tests:</i> See subunit 8.2.
<b>HIV/AIDS</b>	<i>Late HIV disease:</i> Normocytic normochromic red cells, lymphopenia, neutropenia, see also subunit 7.18.55	● WBC and platelets: ↓ ● Other tests: As indicated by HIV-related conditions and ART, see subunit 7.18.55
<b>Anaemia due to chronic disease</b> e.g. tuberculosis	Normocytic, normochromic red cells, becoming microcytic hypochromic as disease progresses. Leukocyte changes reflect condition	● WBC and other tests: As indicated by condition. ● Ziehl Neelsen: To detect AFB if tuberculosis is suspected. ● HIV antibody test

ditions related to leukocytosis or leukopenia, e.g. HIV/AIDS and infections.

- Examination of a faecal specimen for hookworm and schistosome eggs and detection of occult blood (tests described in Part 1 of the book) to establish whether chronic blood loss is contributing to the anaemia.

*Note:* In tropical countries, anaemia is often caused by several factors including iron deficiency, folate deficiency, parasitic infections, bacterial and viral infections, chronic blood loss, and inherited haemoglobinopathies. Interaction of these factors will be reflected in laboratory test results.

Further information on the causes and laboratory investigation of microcytic hypochromic anaemia, macrocytic anaemias, and haemolytic anaemias can be found in subunit 8.2.

#### REFERENCES

- 1 **Mayang S et al.** Estimating the prevalence of anaemia: a comparison of three methods. *Bulletin of the World Health Organization*, 79, (6), 2001.
- 2 **Lewis M.** Anaemia and haemoglobinometry in rural areas. *Africa Health*, November, 2002.
- 3 *Essential medical laboratory service project, Malawi 1998–2002, Final Report.* Malawi Ministry of Health, Liverpool School of Tropical Medicine, DFID. Obtainable from HIV/AIDS Dept, Liverpool School Tropical Medicine, Pembroke Place, Liverpool, L3 5QA, UK.

#### FURTHER READING

**Fleming AF, de Silva PS.** Haematological diseases in the tropics. Ch 15 *Mansons Tropical Diseases*, 21st edition, 2003, Saunders, Elsevier.

**Stott GJ, Lewis SM.** A simple and reliable method for estimating haemoglobin. *Bulletin of the World Health Organization*, 73 (3), pp. 369–373, 1995.

**Lewis SM.** WHO Haemoglobin Colour Scale; *Biomedical Scientist*, (letter) June, p. 359, 1998.

**Fleming AF, Menendez C, Alonso PL.** Malaria related anaemia; *Parasitology Today*, 16, pp. 469–476, 2000.

## 8.5 PCV and red cell indices

**Value of test:** The packed cell volume (PCV), also referred to as haematocrit\* is used to screen for anaemia when it is not possible to

measure haemoglobin accurately and mains electricity is available to operate a microhaematocrit centrifuge.

\***Terminology:** The International Council for Standardization in Haematology (ICSH) recommends that PCV be used when blood is centrifuged in a capillary tube, and the word haematocrit be used when an autoanalyzer is used to compute the value.

The PCV is also used in the investigation of dehydration, burns, dengue haemorrhagic fever (see subunit 7.18.53) and polycythaemia. In the investigation of anaemia, the PCV with haemoglobin value is used to calculate the mean cell haemoglobin concentration (MCHC), described later in this subunit. In African trypanosomiasis endemic areas, examination of the plasma above the buffy coat layer following centrifugation can help to detect trypanosomes as described in subunit 5.8 in Part 1

#### *Value of examining plasma following centrifugation*

Plasma from normal blood appears straw-coloured. In severe iron deficiency the plasma appears colourless. When the blood contains an increased amount of bilirubin, as in haemolytic anaemia, the plasma will appear abnormally yellow. When the plasma is pink-red this indicates a haemolyzed sample (less commonly, haemoglobinaemia). A further blood sample should be tested.

When white cell numbers are significantly increased, this will be shown by an increase in the volume of buffy coat layer. When this is seen, perform a total white cell count and differential count. When lipids are raised, the plasma appears white and cloudy.

#### **Principle of test**

The packed cell volume is that proportion of whole blood occupied by red cells, expressed as a ratio (litre/litre). Anticoagulated blood in a glass capillary of specified length, bore size, and wall-thickness is centrifuged in a microhaematocrit centrifuge at RCF 12 000–15 000 xg for 3–5 minutes to obtain constant packing of the red cells. A small amount of plasma remains trapped between the packed red cells. The PCV value is read from the scale of a microhaematocrit reader or calculated by dividing the height of the red cell column by the height of the total column of blood.

*Note:* Due to trapped plasma, PCV values using a centrifugation technique are 1–3% higher than those obtained when using an electronic cell analyzer which computes the value from the MCV and red cell count.

**Specimen:** To measure the PCV, either well mixed well oxygenated EDTA anticoagulated blood can be used or capillary blood collected into a heparinized capillary. The correct and safe collection of capillary and venous blood are described in subunit 8.3.

## Equipment

- *Microhaematocrit centrifuge*

An example of a microhaematocrit centrifuge is the Hawksley *Haematospin 1300* model shown in Plate 8.2 with essential accessories. It is a robust, stable, fixed speed (11 800 rpm, 13 000 xg RCF) microhaematocrit centrifuge with essential safety features which include a lid interlock, metallic casing and internal rotor lid and imbalance detector. It is fitted with a digital timer, has short acceleration and braking rates, and low noise level when operating. In the event of mains electricity failure, the lid locking mechanism can be easily overridden using the release key provided.

The Hawksley *Haematospin 1300* measures 235 mm deep × 262 mm wide × 272 mm high, weighs 8 Kg (less rotor), and has a power consumption of 380 watts at 200/240 V, 50/60 Hz AC (brushed drive motor). The available rotors include a 24 place haematocrit rotor, (see Plate 8.2a) and a useful multi-combination rotor which holds 8 haematocrits and 16 microtubes, 1.5–4 ml volumes, (see Plate 8.2b).

**Availability:** The Hawksley *Haematospin 1300* microhaematocrit centrifuge 220/240 V model, code 01300-00 or 110 V model, code 01301-00 is manufactured by and available from Hawksley Company (see Appendix 11). The rotor is supplied separately. For the 24 place haematocrit rotor with lid, order code 01971-00, and for the multi-combination rotor with lid, order 01985-00. A microhaematocrit reader is also needed (see following text).

**Important:** Also order extra rim gaskets (code 01504-00, 20 gaskets for haematocrit rotor, code 01989-00, 10 gaskets for combination rotor), and spare pair of motor brushes, code 01978-00. Capillaries and sealant are also required (see following text).

**Centurion microhaematocrit centrifuge** (model CEN. E20B0): This low cost fixed speed (12 000 xg RCF) microhaematocrit centrifuge is fitted with a brushless drive motor and essential safety features. The haematocrit rotor takes 24 capillaries. It is available from Developing Health Technology (see Appendix 11).

- *Capillary tubes for measuring PCV*

These need to be plain or heparinized capillaries, measuring 75 mm in length with an internal diameter of 1 mm and wall thickness of 0.2–0.25 mm. Plain capillaries are often blue-tipped and heparinized capillaries, red-tipped.

**Availability:** Heparinized capillaries (box 1000), code 01605-00 and plain capillaries (box 1000) code 01604-00 are available from Hawksley (see Appendix 11).

- *Sealant*

Capillaries are best sealed using a plastic sealant e.g. *Cristased*, *Miniseal*, or *Seal-Ease*.

**Availability:** *Cristaseal* sealant (box 10 plates), code 01503-00 is available from Hawksley (see Appendix 11). When not in use, the sealant should be kept in a plastic bag to prevent it from drying out.

- *Microhaematocrit reader*

There are two types of microhaematocrit PCV reader, i.e. a spiral reader with magnifier which fits inside the centrifuge allowing PCV measurements to be made after centrifuging with the capillaries in place in the rotor, and a hand-held scale or graph (see Plate 8.2c). A hand-held PCV scale reader can be used to read samples centrifuged in any microhaematocrit centrifuge, whereas a spiral PCV reader can usually be used only with the centrifuge for which it has been designed. The spiral reader cannot be left in place during centrifugation.

## Test method

Whenever possible perform the test in duplicate.

- 1 About three quarters fill\* either:
  - a plain capillary with *well mixed* EDTA anticoagulated blood (tested within 6 hours of collection), or
  - a heparinized capillary with capillary blood.

\*Leave 10–15 mm of the capillary unfilled.

- 2 Seal the *unfilled* end of the capillary using a sealant material (see previous text).

**Heat sealing capillaries:** Avoid using the flame from a spirit lamp or pilot flame from a Bunsen burner to seal a capillary because this can distort the glass, causing breakage when the internal lid is screwed down on the rotor. Red cells may also be lysed by the heated glass. Use of an open flame is also a fire hazard.

- 3 Carefully locate the filled capillary in one of the numbered slots of the microhaematocrit rotor with the sealed end against the rim gasket (to prevent breakage). Write the number of the slot on the patient's form.

Position the inner lid carefully to avoid dislodging the tubes.

- 4 Centrifuge for 5 minutes (RCF 12 000–15 000 xg).

**Note:** If the PCV is more than 0.50, centrifuge for a further 3 minutes to ensure complete packing of the red cells.

- 5 **Immediately after centrifuging**, read the PCV. First check that there has been no leakage of blood from the capillary or breakage.\*

\*If this has occurred, wearing protective gloves, clean the area using a rag soaked in ethanol 70% v/v. Make sure all the glass fragments are removed from the slot and rim.



8.2(a)

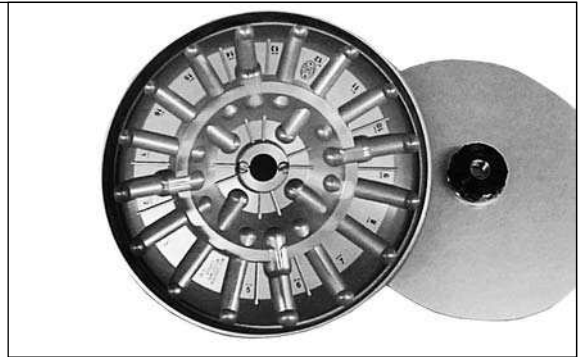

8.2(b)

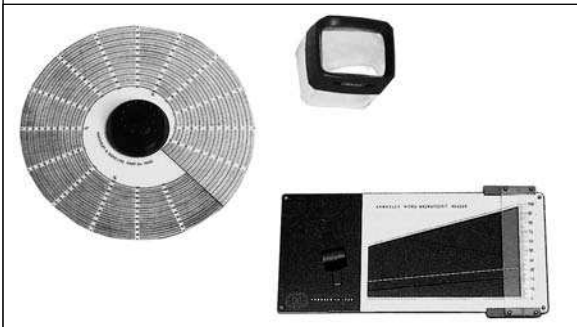

8.2(c)

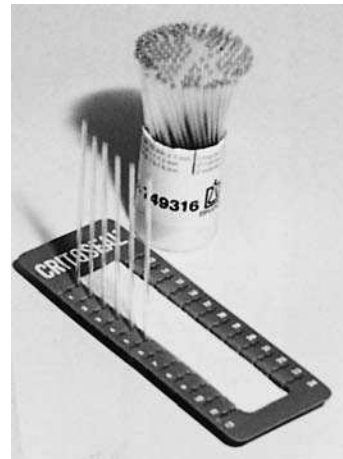

8.2(d)

Plate 8.2(a) Hawksley Haematospin 1300 haematocrit centrifuge with 24 place haematocrit rotor. (b) Combination rotor to take 8 haematocrits and 16 microtubes (1.2–4.0 ml). (c) PCV graph header and spiral reader with magnifier. (d) Sealant used to seal capillaries in numbered tray. *Courtesy Hawksley Ltd*

To read the PCV in a hand-held microhaematocrit reader, align the base of the red cell column (above the sealant) on the 0 line and the top of the plasma column on the 100 line. Read off the PCV from scale. The reading point is the top of the red cell column, just below the buffy coat layer (consisting of WBCs and platelets).

*When no reader is available:* Use a ruler to measure the length of the total column of blood (top of plasma to bottom of red cell column) in mm and the length of the red cell column (base to below buffy coat layer). Calculate the PCV as follows:

$$\frac{\text{Length of red cell column (mm)}}{\text{Length of total column (mm)}} = \text{PCV}$$

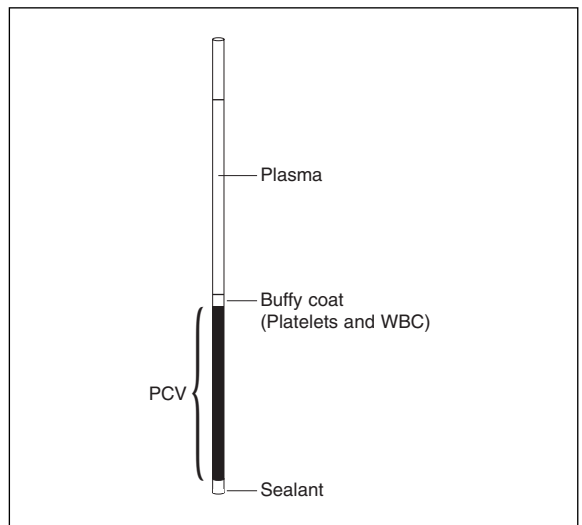

**Caution: Immediately after reading a PCV, discard the capillary into a puncture resistant container** for incineration or burial in a deep covered pit. NEVER leave used capillary tubes on the bench from where they can easily roll to the floor, causing injury from broken glass and a serious biohazard risk.

- 6 Report any abnormal appearance of the plasma (see previous text).

### Quality control of PCV

Tests should be performed in duplicate to check for imprecision (duplicate tests should not differ by more than 5%).

#### Sources of error in measuring PCV

- Centrifuging at too low an RCF or for an insufficient length of time resulting in a PCV value being higher than it should be.
- Delay in reading the PCV after centrifugation, allowing plasma to evaporate.
- Using an anticoagulated blood sample containing excess EDTA (e.g. too little blood added to anticoagulant). This will cause the red cells to shrink, resulting in a PCV value lower than it should be. The opposite occurs if anticoagulated blood is left for more than 6 hours before being tested (the red cells swell, causing a falsely raised value).
- Clots in an anticoagulated blood sample can result in a falsely low PCV value. False values will also be obtained when venous blood samples are not mixed adequately.
- Rises in PCV (up to 6% error) can occur when there is an increase in trapped plasma due to changes in red cell size or shape, e.g. in spherocytosis, microcytosis and macrocytosis. Increases up to 20% of the PCV value can occur in sickle cell disease due mainly to the abnormal shape and rigidity of sickle cells.
- Using capillary tubes that are not designed for measuring PCV.
- Not cleaning and maintaining the microhaematocrit centrifuge as recommended by the manufacturer.

### Interpretation of PCV

In a similar way to haemoglobin levels, PCV values vary according to age, gender, and altitude.

#### PCV reference range (guideline figures), l/l\*

Children at birth	0.44–0.54
Children 2–5 y	0.34–0.40

Children 6–12 y	0.35–0.45
Adult men	0.40–0.54
Adult women	0.36–0.46

\*Reference ranges vary in different populations and in different laboratories. District laboratories should check the above figures with their nearest Haematology Reference Laboratory.

PCV values are reduced in anaemia. Increased values are found when there is loss of plasma as in severe burns, dehydration and in dengue haemorrhagic fever (see subunit 7.18.53). Also in all forms of polycythaemia.

### RED CELL INDICES

Red cell indices most frequently used in the investigation of anaemia are:

- Mean cell haemoglobin concentration (MCHC)
- Mean cell volume (MCV)
- Mean cell haemoglobin (MCH)

#### Measuring red cell indices in district laboratories

**MCHC:** Providing a laboratory is able to measure a PCV as previously described and perform an accurate haemoglobin test, an MCHC can be calculated (see following text).

**MCV and MCH:** To calculate these indices, an accurate red blood cell (RBC) count is required. To perform an accurate RBC count, an electronic cell analyzer is needed. Most district laboratories will not therefore be able to calculate these indices, however, examining a well-stained blood film can help to detect macrocytosis or microcytosis.

#### MCHC

The MCHC gives the concentration of haemoglobin in g/l in 1 litre of packed red cells. It is calculated from the haemoglobin (Hb) and PCV as follows:

$$\frac{\text{Hbg/l}}{\text{PCV (l/l)}} = \text{MCHC g/l}$$

#### Example

If the Hb of an anaemic patient is 81 g/l and PCV is 0.34, the MCHC is:

$$\frac{81}{0.34} = 238 \text{ g/l}^*$$

\*If using g/dl divide the g/l figure by 10.

#### Interpretation of MCHC values

A guideline reference range for MCHC in health is 315–360 g/l (31.5–36.0 g/dl). These figures should be checked locally.

- Low MCHC values are found in iron deficiency anaemia and other conditions in which the red



cells are microcytic and hypochromic (MCHC may be normal in thalassaemia trait). Electronically derived MCHCs are not as sensitive to early iron deficiency.

- An increased MCHC can occur in marked spherocytosis but this is a rare condition. A raised MCHC is more often due to a calculation error or an incorrect haemoglobin or PCV.

### MCV

The mean red cell volume (MCV) provides information on red cell size. It is measured in femtolitres (fl) and is determined from the PCV and electronically obtained RBC count. It can be calculated as follows:

$$\frac{\text{PCV (l/l)}}{\text{RBC} \times 10^{12}/\text{l}} = \text{MCV fl}^*$$

\*A femtolitre (fl) is  $10^{-15}$  of a litre.

*Note:* Most electronic blood cell analyzers measure or calculate MCV as one of their parameters, providing a print out of the value in femtolitres.

#### Interpretation of MCV values

There is some variation in reference ranges for MCV depending on the method used by manufacturers of blood cell analyzers to obtain the MCV value and how an instrument has been calibrated. A guideline reference range is 80–98 fl.

- *Low MCV values:* are found in microcytic anaemias particularly iron deficiency, anaemia of chronic disease and thalassaemia. The MCV is low in infancy (about 70 fl at 1 year of age).
- *Raised MCV values:* are found in macrocytic anaemias, marked reticulocytosis, and chronic alcoholism. The MCV is raised in newborn infants.

### MCH

The MCH gives the amount of haemoglobin in picograms (pg) in an average red cell. It is calculated from the haemoglobin and electronically obtained RBC count:

$$\frac{\text{Hb in g/l}}{\text{RBC} \times 10^{12}/\text{l}} = \text{MCH pg}^*$$

\*A picogram (pg) is  $10^{-12}$  of a gram.

*Note:* Most electronic blood cell analyzers calculate the MCH as one of their parameters, providing a print-out of the value in pg.

#### Summary of red cell indices in common anaemias

Reference range:	MCHC 315–360 g/l	MCV 80–98 fl	MCH 27–32 pg
<i>Anaemias</i>			
<b>Normocytic normochromic</b>	N	N	N
<b>Microcytic hypochromic</b> e.g. Iron deficiency	↓	↓	↓
<b>Macrocytic normochromic</b> e.g. Folate deficiency	N	↑	↑

N = Normal, ↓ = Reduced value,  
↑ = Increased value

#### Interpretation of MCH values

A guideline reference range for MCH in health is 27–32 pg.

- *Low MCH values:* are found in microcytic hypochromic anaemias and also when red cells are microcytic and normochromic. In thalassaemia minor the MCH is low even when anaemia is mild (MCHC is often normal).
- *Raised MCH values:* are found in macrocytic normochromic anaemias. MCH is also raised in newborns.

## 8.6 Counting white cells and platelets

### WHITE CELL COUNT

**Value of test:** A white blood cell (WBC) count is used to investigate HIV/AIDS, infections and unexplained fever, and to monitor treatments which can cause leukopenia. In most situations when a total WBC count is requested it is usual to perform also a differential WBC count as described in subunit 8.7.

#### Principle of test

Whole blood is diluted 1 in 20 in an acid reagent which haemolyzes the red cells (not the nucleus of nucleated red cells), leaving the white cells to be counted. White cells are

counted microscopically using an Improved Neubauer ruled counting chamber (haemocytometer) and the number of WBCs per litre of blood calculated.

*Note:* When after examining a stained blood film, many nucleated red cells are present (more than 10%), the WBC count should be corrected (see end of Test Method).

*Electronic counting of WBCs:* This is described briefly at the end of this subunit.

**Blood sample:** EDTA anticoagulated blood or capillary blood can be used for counting white cells. Heparin or sodium citrate anticoagulated blood must not be used. The count should be performed within 6 hours (blood should not be refrigerated).

*Note:* The correct and safe collection of capillary and venous blood is described in subunit 8.3.

### Equipment

- *Counting chamber (haemocytometer)*

The counting chamber recommended for cell counts is a metallized surface ('Bright-line') double cell Improved Neubauer ruled chamber.

**Non-metallized haemocytometers:** While these are less expensive, they are not recommended. It is more difficult to count WBCs reliably using this type of chamber because the background rulings and cells are not as easily seen. Non-metallized chambers are also more difficult to fill.

The rulings of an Improved Neubauer ruled chamber are shown in Fig. 8.6. The chamber grid has an area of 9 mm<sup>2</sup> and the depth of the chamber (space between cover glass and grid) is 0.1 mm.

**Bürker ruled counting chamber**

This chamber is occasionally found in laboratories and may be the only one available for counting cells. To count white cells using a Bürker Chamber, the four large corner squares are used (4 mm<sup>2</sup>) and the same calculation as described for the Improved Neubauer ruled chamber is used.

- *Counting chamber cover glasses*

Special optically plane cover glasses of defined thickness (designed for use with haemocytometers) are required. Other cover glasses must *not* be used. Manufacturers of counting chambers provide two cover glasses with each chamber. The laboratory should always keep in stock spare cover glasses.

- *Pipettes/calibrated capillaries and safe filling device*

A 20 µl (0.02 ml, 20 cmm) micropipette e.g. white shellback type, or calibrated capillary is

required to measure blood samples. A safe pipette/capillary filler should be used to aspirate and dispense the blood. This can be a simple bulb filler or device as shown on pp. 134–135 in Part 1 of the book.

**Bulb pipettes:** These pipettes are still supplied with haemocytometers by some manufacturers. They should *not* be used for counting WBCs because it is not possible to obtain reliable mixing of the blood and diluting fluid inside the bulb of the pipette. Bulb pipettes are also difficult to clean and expensive to replace.

*Note:* Safe systems for measuring and dispensing blood samples and diluting fluid are described in subunit 4.6 in Part 1 of the book.

- *Hand counter*

To count white cells accurately, a simple inexpensive mechanical hand tally counter as shown in Plate 8.3 is required. Turning the knob on the side returns the counter to zero after each count.

**Availability of supplies for WBC counting:** All of the above mentioned items for counting white cells are available at low cost from Developing Health Technology (see Appendix 11).

### Reagent

WBC diluting fluid\*

Reagent No. 88

\*This is a weak acid solution to which gentian violet is added which stains the nucleus of white cells.

### Test method

- 1 Measure 0.38 ml of diluting fluid and dispense it into a small container or tube.
- 2 Add 20 µl (0.02 ml, 20 cmm) of *well-mixed* EDTA anticoagulated venous blood or free-flowing capillary blood and mix.
 

*Important:* The volume of blood used in the test must be correct. This can be achieved by using the technique illustrated on page 302.
- 3 Assemble the counting chamber:
  - Make sure the central grid areas of the chamber and the special haemocytometer cover glass are completely clean and dry.
  - Slide the cover glass into position over the grid areas and press down on each side until rainbow colours (Newton's rings) are seen. Prior moistening of the chamber surface on each side of the grid areas will help the cover glass to adhere to the chamber.

- Re-mix the diluted blood sample. Using a capillary, Pasteur pipette, or plastic bulb pastette held at an angle of about 45°, fill one of the grids of the chamber with the sample, taking care not to overfill the area.

*Important:* The chamber must be refilled if the sample overfills into the channel beyond the grid or an air bubble forms in the grid area.

- Leave the chamber undisturbed for 2 minutes to allow time for the white cells to settle.

*Note:* To prevent drying of the fluid, place the chamber in a petri dish or plastic container on dampened tissue or blotting paper and cover with a lid as shown in Fig. 8.6(c) on p. 317.

- Dry the underside of the chamber and place it on the microscope stage.

Using the 10× objective with the condenser iris closed sufficiently to give good contrast, focus the rulings of the chamber and white cells. Focus the cells until they appear as small black dots.

- Count the cells in the four large corner squares of the chamber marked W1, W2, W3, W4 in Fig. 8.6 (total area of 4 mm<sup>2</sup>). Include in the count the cells lying on the lines of two sides of each large square as shown in Fig. 8.6(b).

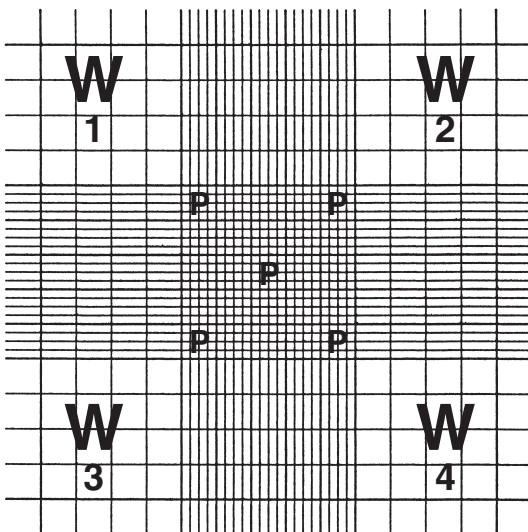

Fig 8.6a Improved Neubauer ruled counting chamber. The four large squares marked W1, W2, W3, W4 are used for counting WBCs and the five small squares marked P are used for counting platelets.

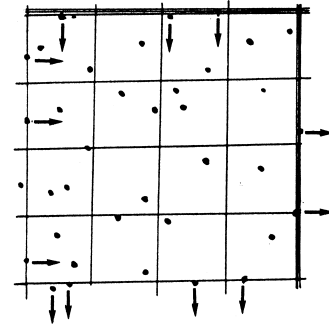

Fig 8.6b Cells lying on two sides of the square are included in the count.

- Report the number of white cells per litre of blood using the following simple calculation:

- Divide the total number of cells counted by 2.
- Divide the number obtained by 10.

The number obtained × 10<sup>9</sup> is the white cell count.

*Example*

Cells counted in 4 squares = 84

84 ÷ 2 = 42

42 ÷ 10 = 4.2

WBC count = 4.2 cells × 10<sup>9</sup>/l

**WBC calculation details**

$$\text{WBC count (per litre)} = \frac{\text{Cells counted} \times 20^* \times 10^6}{4^{\ddagger} \times 0.1^{\S}}$$

where\* = 1 in 20 dilution of blood, ‡ = 4 mm<sup>2</sup> area counted, § = 0.1 mm depth of chamber.

- After performing the count, before the sample dries, dismantle the chamber, wash and dry it. Store it with the cover glass in a safe place.

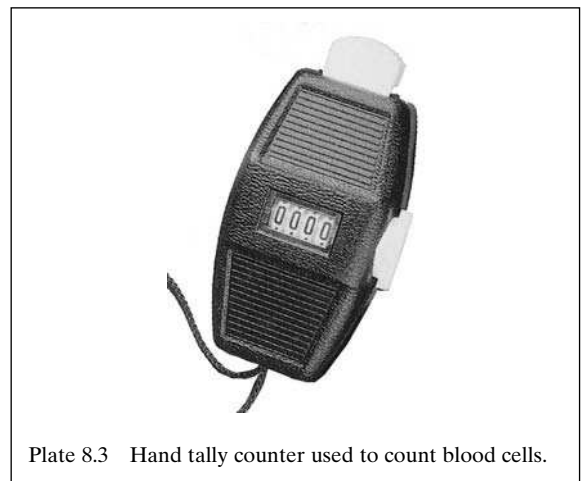

Plate 8.3 Hand tally counter used to count blood cells.

**Counts higher than  $50.0 \times 10^9/l$** 

When a count is higher than  $50.0/10^9/l$ , repeat the count using 0.76 ml of diluting fluid and 20  $\mu$ l of blood. Multiply the result by 2. Very high WBC counts are found in some forms of leukaemia. Always examine a stained thin blood film.

**Counts lower than  $2.0 \times 10^9/l$** 

When a count is lower than  $2.0 \times 10^9/l$ , repeat the count using 0.38 ml of diluting fluid and 40  $\mu$ l of blood. Divide the result by 2.

**Correcting a WBC count when there are many nucleated RBCs**

When more than 10 nucleated red blood cells (RBCs) per 100 WBC are present in the blood film, correct the WBC count as follows:

$$\text{Corrected WBC count} = \frac{\text{Uncorrected WBC count} \times 100}{\text{Nucleated RBCs}^* + 100}$$

\*Number of nucleated RBCs per 100 WBC as seen in stained blood film.

**Quality control of WBC counts**

- Whenever possible perform WBC counts in duplicate. The difference between the two counts (as a percentage of the mean) should not be more than 20%.

**How to calculate the % difference between two counts**

- 1 Record the number of cells counted in Count 1 and Count 2.
- 2 Calculate:
  - the difference in the number of cells counted between the two counts.
  - the mean of the two counts
- 3 Calculate the difference of the two counts as a percentage of the mean.

*Example*

- Cells counted in Count 1 = 88, Count 2 = 76
- Difference in numbers of cells between the two counts:  $88 - 76 = 12$
  - Mean of Count 1 and Count 2:  $\frac{88 + 76}{2} = 82$
  - Difference of the two counts as a % of the mean:  $\frac{12 \times 100}{82} = 14.6\%$

*Note:* When the difference between the two counts is more than 20%, repeat the counts.

- Check that the diluting fluid is free from particles which could be mistaken for WBCs. To do this, fill a counting chamber with a sample of the diluting fluid and examine the grid areas microscopically using the 10 $\times$  objective with *greatly reduced* condenser iris. If the fluid contains par-

ticles resembling WBCs, filter it and recheck or discard the fluid and prepare fresh diluting fluid.

- When examining the blood film, check that there is no major discrepancy between the total white cell count and white cells seen in the blood film.

*External quality assessment*

Whenever possible the Regional or Central Haematology Laboratory should send control blood samples to district laboratories for analysis.

*Sources of error in manual WBC counts*

- Incorrect measurement of blood due to poor technique (see *Text Method*) or using a wet or chipped pipette.
- When using anticoagulated blood, not mixing the blood sufficiently or not checking the sample for clots.
- Inadequate mixing of blood with diluting fluid.
- Not checking whether the chamber and cover glass are completely clean.
- Not using a haemocytometer cover glass.
- Over-filling a counting chamber or counting cells when the sample contains air-bubbles.
- Not allowing sufficient time (2 minutes) for the cells to settle in the chamber.
- Using too intense a light source or not reducing the iris diaphragm sufficiently to give good contrast (poor focusing and difficulty in seeing clearly the cells and rulings are common when using non-metallized haemocytometers, see previous text).
- Not completing counting of the cells before the sample begins to dry in the chamber.
- Counting too few cells (see previous text). Precision increases with the number of cells counted.
- Not correcting a count when the sample contains many nucleated RBCs (see previous text).

**Interpretation of WBC counts**

Reference ranges for white cell counts vary with age with higher counts being found in children. There are also gender differences with higher total WBC and neutrophil counts being found in women of child-bearing age and during pregnancy. Counts also vary in different populations with lower total WBC and neutrophil counts being found in Africans and people of African descent.

*WBC reference range\**

\*These are guideline figures which should be checked locally.

Children at 1 y . . . . .	6.0–18.0 × 10 <sup>9</sup> /l
Children 4–7 y . . . . .	5.0–15.0 × 10 <sup>9</sup> /l
Adults . . . . .	4.0–10.0 × 10 <sup>9</sup> /l
Adults of African origin . . . . .	2.6–8.3 × 10 <sup>9</sup> /l
Pregnant women . . . . .	Up to 15 × 10 <sup>9</sup> /l

**Leukocytosis**

The main causes of a raised WBC count are:

- Acute infections  
e.g. pneumonia, meningitis, abscess, whooping cough, tonsillitis, acute rheumatic fever, septicaemia, gonorrhoea, cholera, septic abortion.  
*Note:* Acute infections in children can cause a sharp rise in WBC count.
- Inflammation and tissue necrosis  
e.g. burns, gangrene, fractures and trauma, arthritis, tumours, acute myocardial infarction.
- Metabolic disorders  
e.g. eclampsia, uraemia, diabetic coma and acidosis.
- Poisoning  
e.g. chemicals, drugs, snake venoms.
- Acute haemorrhage
- Leukaemias and myeloproliferative disorders
- Stress, menstruation, strenuous exercise.

**Leukopenia**

The main causes of a reduced WBC count are:

- Viral, bacterial, parasitic infections  
e.g. HIV/AIDS, viral hepatitis, measles, rubella, influenza, rickettsial infections, overwhelming bacterial infections such as miliary tuberculosis, relapsing fever, typhoid, paratyphoid, buccellosis, parasitic infections including leishmaniasis and malaria.
- Drugs (e.g. cytotoxic) and reactions to chemicals
- Hypersplenism
- Aplastic anaemia
- Folate and vitamin B12 deficiencies (megaloblastic anaemia)
- Bone marrow infiltration (e.g. lymphomas, myelofibrosis, myelomatosis)
- Anaphylactic shock
- Ionizing radiation

**PLATELET COUNT**

**Value of test:** A platelet count may be requested to investigate abnormal skin and mucosal bleeding which can occur when the platelet count is very low (usually below 20 × 10<sup>9</sup>/l). Platelet counts are also performed when patients are being treated with cytotoxic drugs or other drugs which may cause thrombocytopenia.

**Principle of test**

Blood is diluted 1 in 20 in a filtered solution of ammonium oxalate reagent which lyses the red cells. Platelets are counted microscopically using an Improved Neubauer ruled counting chamber and the number of platelets per litre of blood calculated.

**Blood sample:** Use EDTA anticoagulated venous blood. The collection of venous blood is described in subunit 8.3. Capillary blood should not be used because platelets clump as the blood is being collected.

**Equipment**

An Improved Neubauer ruled *Bright-line* counting chamber and other equipment as described previously for WBC counting are required for counting platelets.

**Platelet haemocytometers:** Thin glass chambers for counting platelets by phase contrast microscopy are available. Such chambers are expensive and break easily. They are not essential for counting platelets.

**Reagent**

Ammonium oxalate 10 g/l                      Reagent No. 13  
(1% w/v) diluting fluid.

*Important:* Always filter the fluid before use.

**Test method**

Perform a platelet count within 2 hours of collecting the blood.

- 1 Measure 0.38 ml of filtered ammonium oxalate diluting fluid and dispense it into a small container or tube.

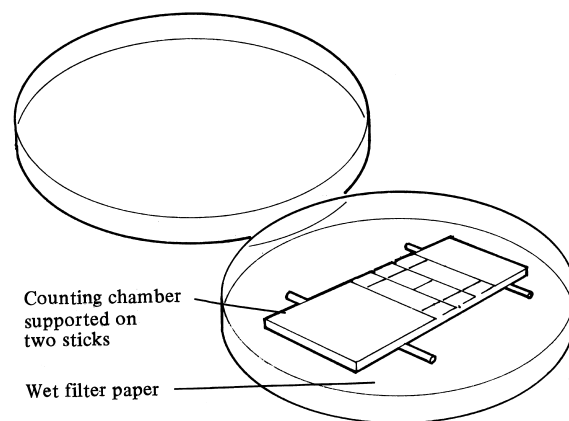

Fig 8.6c Counting chamber in petri dish to prevent drying of the preparation.

- 2 Add 20  $\mu$ l (0.02 ml, 20 cmm) of *well-mixed* anti-coagulated venous blood and mix.
- 3 Assemble the counting chamber and fill it with *well-mixed* sample as described previously in steps 3 and 4 of the method for counting white cells.
- 4 Leave the chamber undisturbed for 20 minutes.

To prevent drying of the fluid, place the chamber in a petri dish or plastic container on dampened tissue or blotting paper and cover with a lid as shown in Fig. 8.6c.

- 5 Dry the underside of the chamber and place it on the microscope stage. Using the 10 $\times$  objective, focus the rulings of the grid and bring the central square of the chamber into view. Change to the 40 $\times$  objective and focus the small platelets. They will be seen as small bright fragments (refractile).

*Note:* If available, use phase contrast microscopy.

- 6 Count the platelets in the small squares marked P as shown in Fig. 8.6 on p. 315.
- 7 Report the number of platelets in 1 litre of blood. This is the actual number of platelets counted  $\times 10^9$ .

*Example*

If 150 platelets are counted, the platelet count is  $150 \times 10^9/l$ .

**Platelet calculation details**

$$\text{Platelet count (per litre)} = \frac{\text{Cells counted} \times 20^* \times 10^6}{0.2^\dagger \times 0.1^\ddagger}$$

where \* = 1 in 20 dilution of blood, † = 0.2 mm<sup>2</sup> area counted ‡ = 0.1 mm depth of chamber

**Quality control**

In district laboratories the most feasible quality control of platelet counts is to follow the test procedure exactly, perform duplicate counts, and examine the platelet fluid microscopically (at the time of performing the count) to ensure it does not contain refractile particles resembling platelets. The mean of the two counts should be calculated as described previously for WBC counts.

*Sources of error in counting platelets*

Sources of error when counting platelets are similar to those mentioned previously for WBC counts. Special care must be taken when counting platelets:

- To check there are no clots in the blood sample.
- To ensure the blood is well mixed with the diluting fluid.
- Not to mistake debris from haemolyzed red cells or particles in the diluting fluid for platelets.
- To ensure the platelets are evenly distributed and not in small clumps (if clumps are present, obtain a new blood sample).
- Not to use too intense an illumination.

*Note:* In some disorders, large platelets may be present.

**Interpretation of platelets counts**

In health there are about  $150\text{--}400 \times 10^9$  platelets/litre of blood. Platelet counts are lower in Africans.

**Thrombocytopenia**

The main causes for a reduction in platelet numbers are:

REDUCED PRODUCTION OF PLATELETS

- Infections, e.g. typhoid, brucellosis
- Deficiency of folate or vitamin B<sub>12</sub>
- Aplastic anaemia
- Drugs (e.g. cytotoxic, quinine, aspirin), chemicals (e.g. benzene), some herbal remedies, alcoholism
- Leukaemias, lymphoma, myeloma, myelofibrosis, carcinoma
- Hereditary thrombocytopenia (rare condition).

INCREASED DESTRUCTION OR CONSUMPTION OF PLATELETS

- Infections, e.g. acute falciparum malaria, dengue, trypanosomiasis, visceral leishmaniasis
- Disseminated intravascular coagulation (DIC)
- Hypersplenism
- Immune destruction of platelets, e.g. idiopathic thrombocytopenic purpura (ITP), onyalaï\*, systemic lupus erythematosus (SLE), other connective tissue disorders, chronic lymphatic leukaemia, lymphomas and HIV/AIDS. Also, exposure to drugs, e.g. quinine, mefloquine, penicillin, and some herbal remedies.

\***Onyalaï:** This is an acquired immune thrombocytopenia mainly found in young people in parts of Southern Africa (e.g. Southern Angola, Northern Namibia). The condition is characterized by haemorrhagic bullae in the buccal mucosa, bleeding from other sites and very low platelet count ( $20 \times 10^9/l$  or below). Bleeding may last for several days or longer. Mortality is about 10% with death resulting from haemor-

rhagic shock (can be reduced with supportive management, including blood transfusion). Most patients recover with a slow return to normal platelet numbers but relapse is common and the condition may become chronic. The cause of onychomycosis is not known (mycotoxins from fungal contamination of grain are suspected).

### **Thrombocytosis**

Causes of an increase in platelet numbers include:

- Chronic myeloproliferative diseases, e.g. essential thrombocythaemia, polycythaemia vera, chronic myeloid leukaemia, myelofibrosis.
- Carcinoma (disseminated)
- Chronic inflammatory disease, e.g. tuberculosis
- Haemorrhage
- Sickle cell disease associated with a non-functioning spleen or after splenectomy.
- Iron deficiency anaemia, associated with active bleeding.

### **Automated blood cell counting using an electronic blood cell analyzer**

Most electronic blood cell analyzers including those manufactured by Beckman Coulter and Sysmex (Toa Medical), count blood cells by impedance.

#### **Principle of impedance analyzers**

Blood cells are diluted in a buffered electrolyte solution. A measured volume of the sample passes through an aperture tube (e.g. 100  $\mu\text{m}$  in diameter) between two electrodes. Interruption of the current by the non-conducting blood cells alters the electrical charge and a pulse is produced. The amplitude of each pulse is proportioned to the volume of the cell which caused it. A threshold circuit ensures only those pulses that exceed the pre-set threshold level are counted. The cell count is determined from the total number of pulses obtained from a measured volume of blood.

*Note:* Analysis of the pulse heights enables mean cell volume (MCV) to be measured and the haematocrit to be calculated from the MCV value and red cell count. In Sysmex impedance analyzers, the haematocrit is determined from voltage pulse data and the MCV calculated from the haematocrit value. The haemoglobin concentration is used with the red cell count, MCV, and haematocrit, to calculate the MCH and MCHC.

Electronic blood cell analyzers are available as semi-automated instruments which require blood samples to be externally diluted (with separate dilutions for counting RBCs and WBCs) and fully automated instruments with internal dilution and simultaneous counting of white cells, red cells, and platelets. The more advanced analyzers in addition to determining haemoglobin, WBC, RBC, platelets, haematocrit, MCV, MCHC, and MCH, also provide red cell distribution width (RDW), platelet distribution width (PDW), and a white cell differential.

#### *Use of an electronic blood cell analyzer*

An electronic blood cell analyzer is appropriate to use when:

- The work load is sufficiently high.
- The capital cost and running costs of the analyzer are affordable.
- Local engineers (trained by the manufacturer of the analyzer) are available to assist with installation of the analyzer, its calibration, regular servicing (about twice a year), and on-site-training and repairs.
- Technologists are trained in the correct use, quality control and maintenance of the analyzer and are able to interpret the data and error codes.
- Essential reagents, calibrants, and control materials are locally and reliably available and also replacement parts can be easily accessed.
- Electricity supplies are sufficiently stable and the analyzer can be protected from excessive dust and extremes of temperature and humidity.

*Note:* Further information on electronic blood cell analyzers, their use, and sources of error can be found in practical haematology textbooks and from analyzer manufacturers and their agents.

## **8.7 Blood films**

**Value of blood films:** Examination of thin blood films is important in the investigation and management of anaemia, infections, and other conditions which produce changes in the appearance of blood cells and differential white cell count. A blood film report can provide rapidly and at low cost, useful information about a patient's condition.

*Important:* Reliable blood film reporting is only possible when laboratory staff are trained adequately in the recognition of blood cells and follow standardized procedures for preparing and staining blood films, reporting morphological changes and performing a differential white cell count. Colour plates showing normal and abnormal blood cells are included in the colour section of this publication.

#### **Thick blood films**

The preparation, staining and reporting of thick blood films

and colour plates illustrating malaria parasites, trypanosomes, and microfilariae can be found in Part 1 of the book.

## MAKING, FIXING AND STAINING BLOOD FILMS

Thin blood films can be made from free-flowing capillary blood or *well mixed* EDTA anticoagulated blood, collected as described in subunit 8.3. To prevent EDTA associated blood changes (explained in subunit 8.3), it is important to make blood films from EDTA anticoagulated blood with as little delay as possible, i.e. within 1 hour of collecting the blood.

**Caution:** Wear protective gloves when handling blood and follow safe working practices (see 3.3–3.4 in Part 1 of the book).

### Technique of making a thin blood film

1 Make a blood spreader from a slide which has *ground glass polished sides\** as follows:

\*Only good quality slides will have ground glass polished sides. Such sides are not necessary for most routine work but they are *essential* to make blood spreaders.

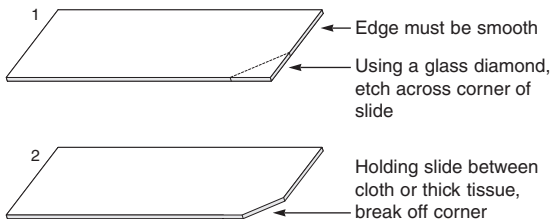

Fig 8.7 Preparing a glass spreader to make blood films.

- Examine each end of the slide and select the end which is *completely* smooth, i.e. no chips in the glass. If one end of the slide is frosted, use the non-frosted end (ensure it is smooth).
  - Using a glass marker, etch across a corner of the slide as shown in Fig. 8.7.
  - Holding the slide between a piece of cloth, break off the corner and discard safely the broken off piece of glass.
- 2 Place a drop of blood on the end of a *clean* dry slide as shown in Fig. 8.8. Avoid making the drop too large (if too large, use a drop from the excess blood to make the film).

#### Slides on which to make blood films

Whenever possible use double frosted end slides because these provide an area for writing clearly the patient's name and number. It is *essential* to ensure slides are washed free from traces of detergent and the surface of the slide is completely clean and not greasy.

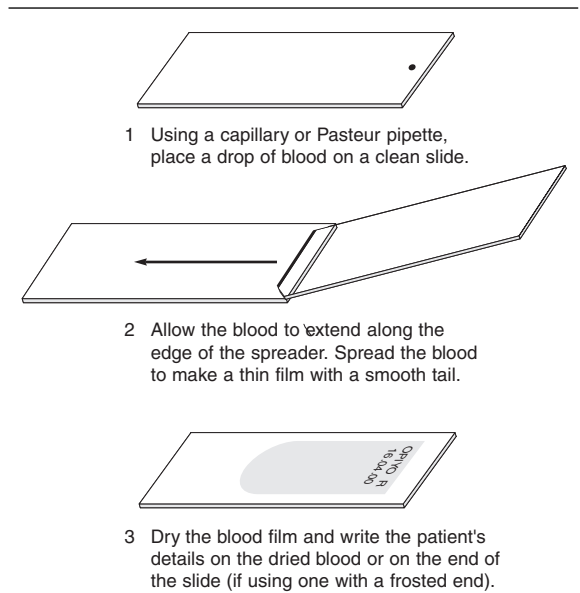

Fig 8.8 Spreading a thin blood film.

- 3 Using a clean smooth edged spreader, draw the spreader back to touch the drop of blood and allow the blood to extend along the edge of the spreader. Holding the spreader at an angle of about  $30^\circ$ , spread the drop of blood to make a film about 40–50 mm in length (two thirds of the slide) as shown in Fig. 8.8.

**Note:** When the blood is from an anaemic patient, increase the angle of spreading and spread the blood more quickly. When the blood is thick and viscous, reduce the angle of spreading and spread the blood more slowly.

- 4 Wipe clean the end of the spreader.
- 5 Immediately air dry the film by waving the slide back and forth. Protect the dried film from dust and insects.
- Note:** When not using a frosted ended slide, write the patient's name and number on the dried blood at the top or along the side of the film using a lead pencil.
- 6 When completely dry and within a few minutes of making the blood film, fix it in absolute methanol (see following text).

#### Features of a well made film

- Not too thick, nor too long
- Free from lines and holes
- Has a smooth 'tail'



*Note:* 'Holes' in a blood film are usually caused by using a slide which is not clean. A jagged 'tail' to a blood film is caused by using a spreader with a chipped end or end that is not clean. Lines across a film are usually due to spreading a film jerkily. Too long a film usually means that too much blood has been used or anaemic 'thin' blood has been spread too slowly or at too shallow an angle. Poorly made blood films and a well made film are shown in the following illustration.

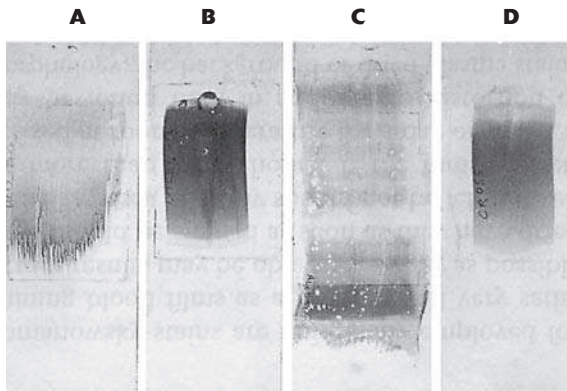

**A:** Blood film with jagged tail made from a spreader with a chipped end. **B:** Film which is too thick. **C:** Film which is too long, too wide, uneven thickness and made on a greasy slide. **D:** A well-made blood film.

*Reprinted from Practical Haematology. Dacie JV, Lewis SM, p. 83, 1995 by permission of the publisher Churchill Livingstone.*

**Important:** Trainees must be given sufficient opportunity to learn how to make thin films correctly. It is impossible to report reliably badly made blood films. Furthermore, fixing and staining badly made blood films, waste expensive reagents. Checking the quality of blood films must form part of quality control procedures.

### Methanol fixing thin blood films

When completely dry, fix a blood film with absolute methanol (methyl alcohol). Place the film on a staining rack and add 1–2 drops of moisture-free methyl alcohol and allow it to dry on the film. Alternatively, the blood film can be immersed in a container of absolute methanol for about 2 minutes, but this is a more expensive method of fixing and also in tropical humid climates there is a greater risk of the alcohol absorbing water from the atmosphere which will result in poor fixing of blood cells.

*Note:* Even when using a Leishman or Wright's staining technique in which the film is first covered with undiluted stain (which fixes and partially stains), prior fixing of thin films is

recommended because the stain may contain moisture which will result in poor fixation.

### Water-free methanol

Satisfactory fixing of thin blood films requires the use of water-free absolute methanol. Poorly fixed cells due to methanol containing water are shown in Plate 8.4. Methanol described as 'Technical' grade must not be used to fix blood films (nor to make stains used to stain blood films). Stock bottles of methanol must be closed tightly after use and the container used to dispense the methanol must have a cap which can be closed completely in between use, e.g. a TK amber glass bottle as shown on p. 167 in Part 1 of the book.

*Note:* When absolute methanol is not available, absolute ethanol (ethyl alcohol) can be used but this is more expensive and usually less available than methanol.

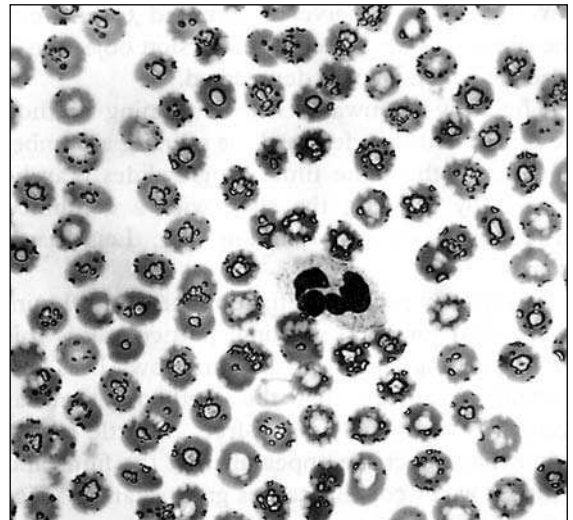

Plate 8.4 Poorly fixed thin blood film. The artefacts shown on the red cells have been caused by fixing the blood film with methanol containing water (10%). *Reprinted from Practical Haematology, Dacie JV, Lewis SM, p. 88, 1995 by permission of the publisher Churchill Livingstone.*

### Staining thin blood films

In district laboratories, thin blood films are usually stained manually using Leishman or Wright's stain. These stains are examples of alcohol containing Romanowsky stains which stain blood cells differentially.

### Romanowsky stains

These stains contain eosin Y which is an acidic anionic dye and azure B and other thiazine dyes (derived from the oxidation, or polychroming, of methylene blue) which are basic

cationic dyes. When diluted in buffered water, ionization occurs. Eosin stains the basic components of blood cells, e.g. haemoglobin stains pink-red, and the granules of eosinophils stain orange-red. Azure B and other methylene blue derived dyes, stain the acidic components of cells. Nucleic acids and nucleoprotein, stain various shades of mauve-purple and violet, the granules of basophils stain dark blue-violet, and the cytoplasm of monocytes and lymphocytes stains blue or blue-grey. The staining reactions of Romanowsky stains are pH dependent which is why the stains are diluted in buffered water of specific pH.

*Note:* There is some variation between batches of most Romanowsky stains due to the different thiazines and impurities they contain. A highly purified Romanowsky stain has been developed which contains only azure B and eosin Y. It is recommended by ICSH for standardized Romanowsky staining but it is very expensive and not needed for routine work.

### Leishman staining technique

Many of the difficulties in reporting blood films, particularly red cell morphology, are due to variable staining. It is important therefore for laboratories to use a reproducible standardized staining technique.

#### Reagents

- Leishman stain\* Reagent No. 48

\*For daily use, store the stain in an amber container, e.g. TK dropper bottle, which can be closed in between use to prevent moisture entering the stain. Make sure the stain is kept in a cool place (not refrigerated) and never left in direct sunlight. Bright light and heat will cause the stain to deteriorate rapidly. Keep the stock stain in a tightly stoppered light opaque (e.g. amber) container in a cool dark place. Renew every 3 months or more often if indicated. Allow 3–5 days before using freshly made stain (to obtain optimum colour reaction).

- pH 6.8 buffered water\* Reagent No. 20

\*Renew if the water becomes cloudy. When refilling the dispensing container, always check that the pH is correct, e.g. by using narrow range pH papers.

#### Method

- 1 Cover the blood film (preferably methanol prefixed, see previous text) with undiluted stain but do not flood the slide. If using a dropper bottle count the number of drops required to cover the film.

*Note:* The undiluted stain not only acts as a fixative but also partially stains the smear. This stage is required to obtain the best possible staining results.

- 2 Add twice the volume of pH 6.8 buffered water (i.e. twice the number of drops as stain). The

diluted stain should not overflow. Ensure the water is well mixed with the stain by blowing on the diluted stain or mixing the stain and water using a plastic bulb pipette. Allow to stain for 10 minutes (time may require adjusting).

*Note:* Diluting the stain in buffered water brings about full staining of the blood cells. The exact staining time to use should be decided when a new batch of stain is prepared.

- 3 Wash off the stain with tap water\* (filtered if not clean). Do *not* tip off the stain, because this will leave a fine deposit covering the film. Wipe the back of the slide clean and stand it in a draining rack for the smear to dry. The blood film should appear neither too pink nor too blue (check results microscopically).

\***Tap water:** If the tap water is highly acidic, resulting in too pink a blood film or highly alkaline, resulting in too blue a blood film, try using boiled cooled water or filtered rain water. If neither of these are suitable, wash the film with pH 6.8 buffered water.

#### Quality control

- When a new batch of stain is prepared, decide the best staining time to use, e.g. stain films made from the same blood at different times, e.g. 5, 7, 10, 12, 15 minutes. Compare the results with a stained control blood film.
- Check the pH of newly prepared buffered water and re-check it at weekly intervals. The pH of the buffered water used to dilute the stain must be correct. It is mainly responsible for the staining reactions.
- Maintain consistency in the staining procedure by following exactly a standard operating procedure (SOP). If the quality of staining changes, always report this to the person in charge of the laboratory and ensure the fault is rectified. The staining procedure should be checked at the beginning of each week.

*External quality assessment:* Whenever possible the Regional or Central Haematology Reference Laboratory should send fixed blood films to district laboratories for staining and reporting (films and report to be returned to the Reference laboratory), and control stained blood films for reporting and comparing with films being stained in the district laboratory. These control stained films should be retained by the district laboratory (protect control films from light).

**Staining results**

Red cells . . . . . Pink-red  
Nucleus of cells . . . . . Purple-violet

**Cytoplasm**

Neutrophils, eosinophils . . . . . Pale pink  
Large lymphocytes . . . . . Clear blue  
Small lymphocytes . . . . . Darker clear blue  
Monocytes . . . . . Grey-blue

**Granules**

Eosinophils . . . . . Orange-red  
Neutrophils . . . . . Mauve-purple  
Toxic granules . . . . . Dark violet  
Basophils . . . . . Dark blue-violet

*Platelets* . . . . . Purple-blue

**Inclusions**

Malaria pigment (in monocytes) . . . . . Brown-black  
Howell-Jolly body . . . . . Purple-violet  
Auer body (in myeloblast) . . . . . Purple-red

*Note:* The appearances of individual blood cells are summarized in Chart 8.6 and illustrated in colour Plates 81–99, 103–105, 107, 109, 111–116. (see colour section)

**Wright's staining technique**

Wright's stain is similar to Leishman stain\*

\*A different polychroming technique is used in the production of Wright's stain and nuclear staining is usually paler than when using Leishman stain.

**Reagents**

- Wright's stain\* Reagent No. 89

\*Storage guidelines as previously described for Leishman stain, also apply to Wright's stain. Staining properties of Wright's stain also deteriorate rapidly when the stain absorbs moisture or is stored at high temperatures or in bright sunlight. Wright's stain should also be renewed every 3 months and left 3–5 days before being used.

- pH 6.8 buffered water Reagent No. 20  
*Note:* Some users of Wright's stain prefer to use pH 6.4 buffered water (see Reagent No. 20)

**Method**

The method of staining thin blood films using Wright's stain is the same as that described previously for Leishman stain except:

- The *same* volume of buffered water as stain is used (not twice the volume).
- The recommended staining time is 5 minutes

but this should be decided locally and re-checked when a new batch of stain is prepared.

*Quality control:* This is the same as described for Leishman stain.

*Staining results:* Similar to those described previously for Leishman stain. When pH 6.4 buffered water is used, more acidic (pink) colour reactions will be seen.

**REPORTING BLOOD FILMS**

Reporting Romanowsky stained thin blood films includes:

- Differential white cell count and white cell morphology
- Red cell morphology
- Comments on platelets (venous EDTA anticoagulated blood sample)
- Other abnormalities, e.g. presence of malaria parasites, trypanosomes, microfilariae, *Bartonella*, and *Borrelia*

**Differential white cell count**

A differential white cell count provides information on the different white cells present in the circulating blood, i.e. neutrophils, lymphocytes, monocytes, eosinophils, basophils (rarely seen). Providing the total WBC count is known, the absolute number of each white cell type, i.e. number of each cell per litre of blood, can be calculated and an assessment made of whether the number of a particular cell type is increased or decreased (compared with the accepted reference range).

**Method**

As previously discussed, it is only possible to report blood films reliably providing the thin blood film is well made and correctly stained. Allow the stained film to dry completely before examining it.

- 1 Place a drop of immersion oil on the lower third of the blood film and cover with a clean cover glass.
- 2 Examine the film microscopically. Focus the cells using the 10× objective with the condenser iris closed sufficiently to see the cells clearly. Check the staining and distribution of cells.
- 3 Move to a part of the film where the red cells are just beginning to overlap and bring the 40× objective into place. Open the iris diaphragm more.

- 4 Systematically examine the blood film and count the different white cells seen in each field, preferably using an automatic differential cell counter, or if this is not available, record the count in chart form as shown on fig. 8.9.

*Note:* Features which help to identify white cells are summarized in Chart 8.6.

#### Differential WBC cell counter

Electronic and mechanical differential cell counters are available. A 6 digit mechanical cell counter is shown in Plate 8.5. It is recommended because it is robust, easy to use and does not require batteries or mains electricity to operate it. When a total of 100 cells have been counted, there is an audible signal. The numbers of each cell type are read from the display windows. Turning the knob on the side returns all the displays to zero. A counter as shown in Plate 8.5 is available from Developing Health Technology (see Appendix 11).

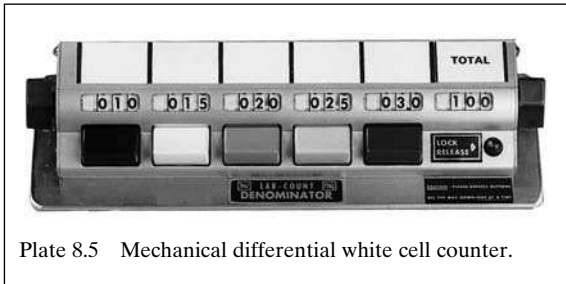

Plate 8.5 Mechanical differential white cell counter.

- 5 Calculate the absolute number of each white cell type by multiplying the number of each cell counted (expressed as a decimal fraction) by the total WBC count.

#### Example

If: Percentage of neutrophils counted = 80%  
i.e. 0.80 when expressed as a decimal fraction.

If total WBC count =  $8.6 \times 10^9/l$

Absolute neutrophil count is  $0.80 \times 8.6 = 6.9 \times 10^9/l$

#### Reporting absolute numbers of each cell type

When only the percentage of each cell type is reported in a differential WBC count and not the number per litre of blood (absolute count), this can be misleading, e.g. in the above example, a neutrophil percentage count of 80% is 'abnormal' but when expressed in absolute numbers the neutrophil count is  $6.9 \times 10^9/l$  which is within the normal reference range for an adult (see reference range figures).

- 6 Report the presence of white cell abnormalities, including:
- Left shift of neutrophils and toxic granulation
  - Hypersegmented neutrophils
  - Reactive (atypical) lymphocytes
  - Malaria pigment in white cells

	Neut	Lym	Eos	Mon	Bas
1					
2	####				
3	####				
4	####				
5					
6	####				
7	####				
8	####				
9	####				
10	####				
TOTAL	61	29	5	5	-

Fig 8.9 Useful WHO modified chart to record white cells when a differential WBC counter is not available. Ten cells are recorded in each line. When 10 cells have been recorded, move to the next line. When 10 cells have been recorded in line 10, a total of 100 white cells will have been counted.

**Neut** = Neutrophils, **Lym** = Lymphocytes, **Eos** = Eosinophils, **Mon** = Monocytes, **Bas** = Basophils.

*Note:* WBC abnormalities and their significance are summarized in Chart 8.6.

*Leukaemia, leukaemoid reaction, myelomatosis:* Features of these conditions are described in subunit 8.2.

- 7 Report the appearance of the red cells, including:
- Variations in red cell staining, e.g. hypochromic cells, polychromatic cells, dimorphic blood picture. If normal, refer to the red cells as normochromic.
  - Variations in red cell size, e.g. microcytes, macrocytes, spherocytes, significant anisocytosis. If normal in size, refer to the red cells as normocytic.
  - Cells of abnormal shape or form, including pencil cells, sickle cells, target cells, fragmented cells (schistocytes), tear drop cells, 'bite' cells, burr cells, cells showing rouleaux, significant poikilocytosis.
  - Cells with inclusions, e.g. nucleated red cells, megaloblasts, cells containing Howell-Jolly

bodies, cells showing basophilic stippling, cells containing malaria parasites, cells containing *Bartonella* organisms.

The degree of each type of red cell abnormality can be reported in plus signs as follows:

- ++++ (very marked)
- +++ (marked)
- ++ (moderate)
- + (slight but significant)

Nucleated red cells, target cells, sickle cells, megaloblasts, malaria parasites, Howell-Jolly bodies, pencil cells, and other abnormal red cells can be reported as many, moderate numbers, few, occasional.

*Note:* Descriptions of red cell abnormalities and their significance are summarized in Chart 8.6.

- 8 If the blood film has been made from EDTA anti-coagulated venous blood, comment when platelet numbers appear greatly reduced or have an abnormal appearance (normal platelets are shown in colour Plates 81–83). Perform a platelet count when platelet numbers appear significantly reduced (check first that the blood sample is free from clots) or increased.

**Differential WBC reference range\***

\*These values are guideline figures only. They should be checked locally. Neutrophil counts are lower in Africans and Afro-Caribbean people.

	Absolute number	Percentage
<b>ADULTS</b>		
Neutrophils . . . .	1.5–7.5 × 10 <sup>9</sup> /l	(40–75%)
Lymphocytes <sup>‡</sup> . . . .	1.2–4.0 " "	(21–40%)
Monocytes . . . . .	0.2–1.0 " "	(2–10%)
Eosinophils . . . . .	0.02–0.6 " "	(1–6%)
Basophils . . . . .	0.01–0.1 " "	(0–1%)
<b>CHILDREN (2–6 y)</b>		
Neutrophils . . . .	1.5–6.5 × 10 <sup>9</sup> /l	(20–45%)
Lymphocytes <sup>‡</sup> . . . .	6.0–8.5 " "	(45–70%)
Monocytes . . . . .	0.1–1.0 " "	(2–10%)
Eosinophils . . . . .	0.3–1.0 " "	(1–6%)
Basophils . . . . .	0.01–0.1 " "	(0.1–1%)

<sup>‡</sup>In an adult, lymphocytes are mainly of the small type whereas in a child, large lymphocytes predominate.

*Important:* District laboratory staff should always seek the advice of an experienced haematologist when unable to report a blood film with confidence, and always when a serious blood disorder is suspected, e.g. leukaemia or myelomatosis. The original blood film and three other well made fixed but unstained blood films from the patient should be sent to the Haematology Reference Laboratory with comprehensive clinical notes, treatment details and the results of other laboratory tests.

**Neutrophilia** An absolute increase in neutrophils can be found in:

- Acute bacterial infections (often with left shift), e.g. abscesses, wound infections, meningitis, pneumonia, gonorrhoea, urinary tract infections
- Tissue damage, e.g. burns, trauma
- Snake envenomation
- Acute myocardial infarction
- Acute haemorrhage
- Malignant diseases
- Myeloid leukaemia
- Reactions to some drugs e.g. steroid therapy, and chemicals
- Metabolic disorders
- During pregnancy (normal) and delivery

**Neutropenia** Common causes of a reduced neutrophil count are:

- Bone marrow failure
- Viral infections, e.g. HIV disease, hepatitis, influenza
- Bacterial infections, e.g. typhoid fever, brucellosis, miliary tuberculosis, overwhelming septicaemia
- Splenomegaly
- Megaloblastic anaemia
- Drugs

**Lymphocytosis** An absolute increase in lymphocytes can be found in:

- Infections in children, e.g. whooping cough, mumps, measles, chicken pox
- Bacterial infections, e.g. brucellosis, typhoid fever, chronic tuberculosis, syphilis
- Protozoal infections, e.g. malaria, toxoplasmosis
- Infectious mononucleosis
- Cytomegalovirus infection
- Lymphocytic leukaemia, lymphomas

**Lymphopenia** Common causes of a reduced lymphocyte count are:

- HIV/AIDS
- Severe bone marrow failure
- Hodgkins disease
- Some acute viral infections

**Monocytosis** An absolute increase in monocytes can be found in:

- Chronic bacterial infections, e.g. tuberculosis, brucellosis, typhoid, bacterial endocarditis
- Protozoal infections, e.g. malaria, trypanosomiasis
- Chronic myelomonocytic leukaemia
- Hodgkins disease

**Eosinophilia** An absolute increase in eosinophils can be found in:

- Helminth infections, e.g. hookworm infection, strongyloidiasis, filariasis, trichinosis, schistosomiasis, hydatid disease

- Allergic conditions, e.g. asthma, hay fever, urticaria, food allergies, drug allergies
- Skin diseases, e.g. psoriasis, dermatitis
- Pulmonary eosinophilia
- Hodgkins disease, lymphoma, malignancies
- Connective tissue diseases

**Basophilia** An absolute increase in basophils can be found in:

- Myeloproliferative disorders
- Some allergies
- Myxoedema

**Chart 8.6 Morphology of normal and abnormal blood cells in Romanowsky stained blood film**

**NORMAL WHITE CELLS**

<i>Cell</i>	<i>Size</i>	<i>Nucleus</i>	<i>Cytoplasm</i>
<b>Neutrophil</b> Colour Plate 81, 83	12–15 $\mu\text{m}$	Lobed nucleus with 3–5 lobes separated by chromatin threads. Clumped chromatin	Pale staining and containing small neutrophilic mauve staining granules
<b>Small lymphocyte</b> Colour Plate 83	10–12 $\mu\text{m}$	Dark mauve, compact with clumped chromatin	Thin rim of blue cytoplasm surrounds the nucleus
<b>Large lymphocyte</b> Colour Plate 81	12–16 $\mu\text{m}$	Round or oval, sometimes indented.	More cytoplasm than small lymphocyte, pale blue, often containing small purple granules
<b>Monocyte</b> Colour Plate 83	15–20 $\mu\text{m}$	Round, indented, or folded. Stains mauve with delicate chromatin pattern	Clear grey-blue cytoplasm, containing <i>fine</i> granules and sometimes vacuoles
<b>Eosinophil</b> Colour Plate 82	12–17 $\mu\text{m}$	Lobed nucleus, usually 2 lobes, staining dark mauve	Pale-staining cytoplasm, containing orange-red granules and sometimes vacuoles
<b>Basophil</b> Colour Plate 84	10–12 $\mu\text{m}$ (rarely seen)	Bilobed (but usually obscured by granules)	Contains large darkly staining blue-violet granules

**WHITE CELL ABNORMALITIES**

<i>Abnormality</i>	<i>Description</i>	<i>Significance of abnormality</i>
<b>Left shift of neutrophils</b> <b>Toxic granulation</b> Colour Plates 85 and 86	Immature neutrophils and precursor cells seen, e.g. band cells, metamyelocytes and sometimes myelocytes (see subunit 8.2). Cells may contain darkly staining coarse granules (toxic granulation) and sometimes vacuoles	Commonly seen in acute bacterial infections and inflammatory conditions

<i>Feature/Abnormality</i>	<i>Description</i>	<i>Significance of feature/abnormality</i>
<b>Hypersegmentation of neutrophils</b> Colour Plate 97	Nucleus of more than 5% of neutrophils has 5 or more distinct lobes	Most frequently seen in megaloblastic anaemia (due to folate or vitamin B <sub>12</sub> deficiency)
<b>Reactive (atypical) lymphocytes</b> Colour Plate 94	Irregularly shaped larger than normal lymphocytes with a less dense nucleus (may contain nucleoli). Abundant blue cytoplasm, often appearing dark blue and folded at periphery of cell	Typically seen in acute malaria, infectious mononucleosis, cytomegalovirus infection, and other viral infections, and often in acute infections in children, e.g. whooping cough
<b>Malaria pigment in white cells</b> Colour Plate 115	Brown-black pigment often seen in monocytes and occasionally neutrophils	Well-established falciparum malaria
<b>Leukaemia, leukaemoid reaction, myeloma</b>	Features are as described in subunit 8.2 and summarized in Chart 8.4, see also colour Plates 87–90 and 93	

### RED CELL APPEARANCES

<i>Feature/Abnormality</i>	<i>Description</i>	<i>Significance of feature/abnormality</i>
<b>Normal red cell</b> Colour Plate 96	Measures about 8 µm in diameter, i.e. normocytic. Stains pink-red with a small area of central pallor (no more than 1/3 of cell's diameter), i.e. normochromic	—
<b>Hypochromic cells</b> Colour Plate 98	Pale staining red cells with increased area of central pallor	Iron deficiency anaemia, thalassaemia syndromes, anaemia of chronic disease, sideroblastic anaemia (rare)
<b>Polychromasia</b> Colour Plates 109, 111, 112	Blue-grey or blue-mauve staining of immature cells (reticulocytes) which are larger in size than normal red cells	Post haemorrhage and haemolytic anaemias with effective bone marrow response and following treatment for anaemia. See also subunit 8.9
<b>Dimorphic appearance</b>	Presence of two different populations of red cells, e.g. hypochromic cells with normal red cells, or hypochromic cells with macrocytic cells	Commonly seen following successful treatment for anaemia and post-blood transfusion
<b>Microcytosis</b> Colour Plate 98	Smaller than normal red cells, having a diameter of usually less than 6.5 µm	Iron deficiency, anaemia of chronic disease, thalassaemia syndromes, secondary sideroblastic anaemia
<b>Macrocytosis</b> Colour Plate 97	Larger than normal red cells, having a diameter greater than 8 µm	Folate and vitamin B <sub>12</sub> deficiencies (oval macrocytes), liver disease and alcoholism (round macrocytes)

<b>Spherocytosis</b> Colour Plate 109	Small densely staining spherical red cells with no central pallor	Haemolytic anaemia due to warm autoantibody, drugs, snake venom, infection with <i>C. perfringens</i> . Also hereditary spherocytosis, bartonellosis, ABO haemolytic disease of the newborn
<b>Anisocytosis</b>	Unequal variation in the size of red cells	Associated with many anaemias
<b>Pencil cells</b> Colour Plate 98	Elongated narrow red cells	Feature of iron deficiency anaemia
<b>Sickle cells</b> Colour Plate 99	Elliptical cells with pointed ends, crescent shaped, or boat shaped cells	Sickle cell disease, including sickle cell anaemia ( $\beta^S/\beta^S$ ) sickle cell/ $\beta$ thalassaemia, HbSC disease
<b>Target cells (leptocytes)</b> Colour Plate 103	Cells which stain in the centre and periphery with an unstained ring in between	Thalassaemia syndromes, sickle cell disease, HbC disease, HbD disease, obstructive jaundice, liver disease, post-splenectomy
<b>Schistocytes</b> Colour Plate 112	Irregularly contracted red cell fragments, often with projections (spicules)	Associated with red cell damage due to severe burns, drugs, toxins, DIC. Also found in uraemia and pre-eclampsia
<b>Burr cells (echinocytes)</b>	Small cells or cell fragments with spicules	Uraemia, acute blood loss, pyruvate kinase deficiency
<b>Acanthocytes</b> Colour Plate 111	Irregularly crenated cells with irregularly spaced sharp projections (to be differentiated from crenated red cells)	Associated with rare abnormalities of phospholipid metabolism and some liver disorders
<b>Tear drop cells</b>	Cells shaped like tear drops	Myelofibrosis, extramedullary erythropoiesis
<b>Half-ghost (blister) cells</b> Colour Plate 107	Irregularly contracted cells with separation of haemoglobin from the cell membrane	G6PD deficiency during haemolytic crisis, oxidative damage (usually drug-induced)
<b>Poikilocytosis</b>	Significant variation in cell shape	Feature of many anaemias
<b>Rouleaux</b> Colour Plate 93	Cells joined together side by side like stacks of coins	Myelomatosis, macroglobulinaemia, conditions in which fibrinogen is raised, inflammatory disorders, malignancy
<b>Nucleated red cells</b> Colour Plates 99 and 114	Precursor red cells containing a nucleus	Sickle cell disease, $\beta$ thalassaemia major, other severe anaemias, haemolytic disease of the newborn, leukaemias, autoimmune haemolytic anaemias, <i>C. perfringens</i> septicaemia



<i>Feature/Abnormality</i>	<i>Description</i>	<i>Significance of feature/abnormality</i>
<b>Megaloblast</b> Colour Plate 97	Larger than normal red cell (10–20 $\mu\text{m}$ ) with an immature nucleus (fine lacy chromatin pattern). Cytoplasm stains blue	Megaloblastic anaemia (deficiency of folate or vitamin B <sub>12</sub> )
<b>Howell-Jolly bodies</b> Colour Plate 113	Darkly staining small spherical body (nuclear remnant) seen in red cells. Sometimes more than one to a cell. Variable in size	Megaloblastic anaemia, thalassaemia syndromes, haemolytic anaemias, hyposplenism, post-splenectomy
<b>Basophilic stippling</b>	Seen as small darkly-staining granules in red cells (aggregations of ribosomes)	Found in thalassaemia syndromes, megaloblastic anaemia, haemolytic anaemias, liver disease, and poisoning with heavy metals, e.g. lead

## 8.8 Erythrocyte sedimentation rate (Westergren technique)

**Value of test:** The erythrocyte sedimentation rate (ESR) is a non-specific test. It is raised in a wide range of infectious, inflammatory, degenerative, and malignant conditions associated with changes in plasma proteins, particularly increases in fibrinogen, immunoglobulins, and C-reactive protein. The ESR is also affected by many other factors including anaemia, pregnancy, haemoglobinopathies, haemoconcentration and treatment with anti-inflammatory drugs (see later text).

Moderately raised sedimentation rates can sometimes be found in healthy people, particularly those living in tropical countries and a 'normal' ESR cannot exclude disease. In many tropical countries, ESR measurements have been discontinued because they add little to diagnosing disease, assessing its progress and monitoring response to treatment. When performed, test results must be interpreted in conjunction with clinical findings and the results of other laboratory tests.

### Principle of test

When citrated blood in a vertically positioned Westergren pipette is left undisturbed, red cells aggregate, stack together to form rouleaux, and sediment through the plasma. The ESR is the rate at which this sedimentation occurs in 1 hour as indicated by the length of the column of clear plasma above the red cells, measured in mm. Fibrinogen, immunoglobulins, and C reactive protein increase red cell aggregation. Sedimentation is increased when the ratio of red cells to plasma is altered, e.g. in anaemia. Sedimentation is reduced

when the red cells are abnormally shaped, e.g. sickle cells. High temperatures (over 25°C) increase sedimentation.

### Equipment

- Westergren ESR pipette

Glass Westergren pipettes or when available, disposable plastic Westergren pipettes can be used. Westergren pipettes measure 300 mm in length (plastic pipettes are often shorter) and are graduated from 0–200 mm. The diameter should not be less than 2.55 mm. When reusing pipettes, care must be taken to ensure the pipettes are completely clean and dry.

- Westergren ESR stand with levelling device\*

\*Most Westergren stands are designed for use with disposable 'closed tube' ESR systems to minimize biohazard risks associated with handling blood. Unfortunately such systems are expensive.

### Reusable ESR systems

When using a reusable ESR system, an ESR stand must be used which enables blood to be aspirated safely, *not mouth-pipetted*. A simple reusable system suitable for use in a district laboratory is shown in Plate 8.6. Blood is aspirated using 2 ml plastic syringes. A plastic connector attaches the syringe to the pipette (cone-shaped piece of plastic, e.g. as found at the end of a catheter or infant's feeding tube).

- Timer capable of timing accurately 1 hour, e.g. mechanical 60 minute timer as shown on p. 172 in Part 1 of the book.

### Reagent

Tri-Sodium citrate, 32 g/l  
(3.2% w/v) anticoagulant

Reagent No. 73

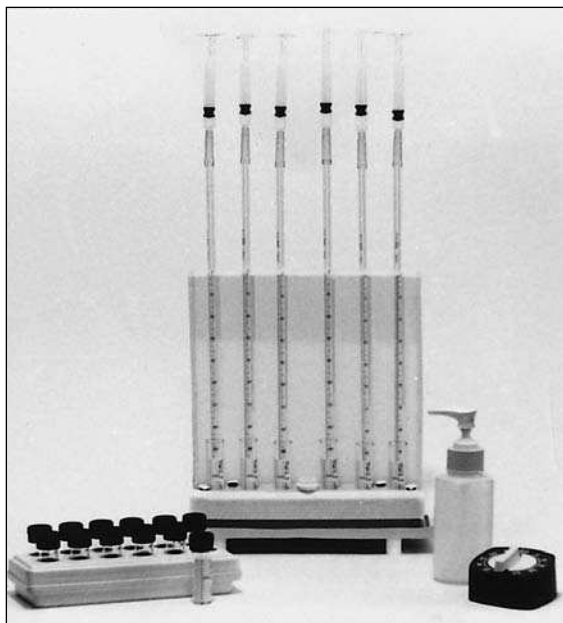

Plate 8.6 Reusable ESR system with safe means of aspirating the blood. *Courtesy of Developing Health Technology.*

Store the reagent at 4–8 °C. Renew if it becomes cloudy.

**Specimen:** Either venous blood collected directly into sodium citrate and tested within 2 hours, or EDTA anticoagulated blood diluted in sodium citrate can be used. If EDTA blood is used and kept refrigerated at 4–8 °C, citrate dilution of the blood and testing can be delayed for up to 6 hours.

#### Test method

- 1 Pipette 0.4 ml of sodium citrate anticoagulant into a small container.  
*Note:* If using previously prepared sodium citrate containers, check that there has been no leakage of the anticoagulant.
- 2 Add 1.6 ml of venous blood or EDTA anticoagulated blood and mix well. Remove the cap of the container and place the sample in the ESR stand (make a note of the number in the patient's notes). Insert a Westergren pipette and ensure it is positioned vertically.
- 3 Using a safe suction method, draw the blood to the 0 mark of the Westergren pipette, avoiding air bubbles.

- 4 Check that the ESR stand is level by making sure that the bubble in the spirit level is central. If required, adjust the screws on the bottom of the stand. Re-check that the pipette is vertical.
- 5 Set the timer for 1 hour. Ensure the ESR stand and pipette will not be exposed to direct sunlight.
- 6 After exactly 1 hour, read the level at which the plasma meets the red cells in mm\*.

\*Some Westergren pipettes are marked 0, 10, 20 etc. and some are marked 0, 1 (equivalent to 10 mm), 2 (equivalent to 20 mm) etc., therefore read the graduations carefully.

*Note:* Severe anaemia or marked reticulocytosis may prevent a clear dividing line forming between the plasma and red cells.

- 7 After reading the ESR, return the blood to its container, remove carefully the pipette and soak it in sodium hypochlorite 2 500 ppm av Cl (0.25%) disinfectant.

Dispose of the blood safely and decontaminate the container before washing it and also the ESR stand as described in subunit 3.4 in Part 1 of the book.

#### Quality control

The most practical way of controlling ESR tests is to follow the test method exactly.

#### Sources of error

- Using the wrong volume of blood to anticoagulant.
- Blood not sufficiently mixed with anticoagulant.
- Clots in the blood. Even the smallest fibrin clot in the sample will invalidate the test result.
- Air bubbles at the top of the column.
- Testing blood samples at the hottest time of the day, or leaving tests in direct sunlight. Temperatures over 25 °C increase sedimentation.
- Using a pipette which is not clean or not dry.
- Pipette not positioned vertically. Even slight variations from the upright increase sedimentation.
- Not checking whether the ESR stand is level on the bench.
- Placing an ESR stand on the same bench as a

centrifuge where vibration will interfere with sedimentation.

- Measuring the ESR when a patient is dehydrated.

### Interpretation of ESR test results

#### Reference range

Men ..... Up to 10 mm/hour\*  
 Women ..... Up to 15 mm/hour\*  
 Elderly ..... Up to 20 mm/hour\*

\*These figures should be checked locally. Higher values may need to be applied in tropical countries.

*Note:* Higher values are obtained during menstruation, pregnancy, puerperium.

Because of the many factors that affect red cell sedimentation, slightly and moderately raised values may not be significant, particularly in tropical countries. Markedly raised values should be investigated.

#### Causes of a significantly raised ESR

- Anaemia due to any cause
- Acute and chronic inflammatory conditions and infections including:
  - HIV disease
  - Tuberculosis\*
  - Acute viral hepatitis
  - Arthritis
  - Bacterial endocarditis
  - Pelvic inflammatory disease
  - Ruptured ectopic pregnancy
  - Systemic lupus erythematosus

\*When the ESR is used to monitor progress during treatment, ESR values do not fall when a patient with tuberculosis is also co-infected with HIV.

- African trypanosomiasis (rises rapidly)
- Visceral leishmaniasis
- Myelomatosis, lymphoma, Hodgkins disease, some tumours
- Drugs, including oral contraceptives

*Note:* The ESR is not usually significantly raised in typhoid, brucellosis, malaria, infectious mononucleosis, uncomplicated viral diseases, renal failure with heart failure, acute allergy, peptic ulcer.

#### Reduced ESR

Sedimentation is falsely low in polycythaemia, dehydration, dengue haemorrhagic fever, and other conditions associated with haemoconcentration.

Abnormally shaped red cells as in sickle cell disease also lower sedimentation rate.

Other situations in which sedimentation is reduced include DIC (fibrinogen is consumed) and treatment with anti-inflammatory drugs.

## 8.9 Reticulocyte count Methaemoglobin reduction test

### Reticulocyte count

**Value of test:** Reticulocytes are immature red cells normally present in small numbers in the blood (up to 2%). Reticulocyte numbers increase when there is an increase in erythropoietic activity. A reticulocyte count assesses bone marrow activity, e.g. whether there is an effective erythropoietic response when there is a reduction in the number of red cells due to haemolysis or haemorrhage. A reticulocyte count is also of value in monitoring the erythropoietic response of an anaemic patient following treatment.

#### Principle of test

An isotonic solution of a supravital stain (i.e. one that stains living material) such as New methylene blue or brilliant cresyl blue is incubated with a few drops of blood. To detect ribosomal RNA in reticulocytes, the red cells must be stained while they are still living (not fixed). A thin preparation is made and the reticulocytes counted microscopically. Reticulocytes are recognized by the violet-blue stained granules of ribosomal RNA (reticulin) they contain. The reticulocyte count is expressed as a percentage, or preferably in absolute numbers when an electronic analyzer RBC count is available.

#### Reagent

10 g/l (1% w/v) New methylene blue Reagent No. 61  
 blue or brilliant cresyl blue (No. 17)\*

\*New methylene blue gives better staining of reticulin in reticulocytes than brilliant cresyl blue. It is chemically different from other forms of methylene blue.

Keep the stain refrigerated and always filter it before use.

**Specimen:** Use well-mixed EDTA anticoagulated blood or if the patient is a young child, use free-flowing capillary blood.

#### Test method

1 Filter 2–3 drops of the stain into a small tube or vial.

- 2 Add about 4 drops\* of EDTA anticoagulated blood or capillary blood and mix well.

\*The amount of blood used is not critical. Use at least twice the volume of blood to stain if the patient is severely anaemic.

- 3 Incubate at room temperature for 20 minutes or 10–15 minutes at 35–37°C.
- 4 Mix gently to resuspend the red cells and using a capillary or plastic bulb pipette, transfer a drop of the stained blood to each of two slides. Spread to make two evenly spread *thin* films. Wave the slides back and forth to air-dry the films. Protect the films from dust and insects until the count can be performed.
- 5 Count the reticulocytes microscopically. Use the 10× objective (with reduced condenser iris diaphragm) to check the distribution of the red cells. Select an area where the red cells can be seen individually, add a drop of immersion oil, and examine using the oil immersion objective (open more the condenser iris diaphragm).
- 6 Count systematically (i.e. consecutive fields), 500 red cells (1 000 if there are very few reticulocytes), noting the number that are reticulocytes. Calculate the percentage of reticulocytes (see following text).

#### *Appearance of reticulocytes*

Reticulocytes appear as pale green-blue stained cells containing dark blue-violet inclusions in the form of small granules, distributed irregularly as shown in colour Plate 110. Mature red cells stain pale green-blue.

*Counting reticulocytes:* A convenient method of counting reticulocytes is to reduce the size of the microscope field by inserting in each eyepiece a circular piece of black (opaque) paper which has a punched out hole of about 5 mm.

To calculate % of reticulocytes:

- Using a hand tally counter, count a total of 500 red cells, noting on paper the number of cells that are reticulocytes (alternatively use two hand tally counters or a white cell differential counter).
- Multiply the number of reticulocytes counted by 2.
- Divide the figure by 10 to obtain the percentage figure.

- 7 Report the reticulocyte count as the average of the two counts performed (from the two separate preparations).

#### **Quality control**

Quality control of reticulocyte counts should include filtering the stain before use and checking the best staining time to use when a new batch of stain is made. Always perform duplicate counts (preferably using a different person for each count). The two counts should agree within 20% of each other.

#### *Sources of error*

- Not mixing adequately the stained blood prior to making the blood films.
- Not counting the cells accurately or counting too few cells.
- Using stain which has become contaminated and has not been filtered before use.
- Confusing Heinz bodies (see following text) or precipitated stain for the reticulin of reticulocytes.

#### **Interpretation of reticulocyte counts**

##### *Reference range\**

\*Figures should be checked locally

Infants at birth . . . . . 2–5%  
Children and adults . . . . . 0.5–2.5%

*Note:* Whenever an RBC count is available, express the reticulocyte in absolute numbers.

***Raised reticulocyte counts:*** Found when there is an increase in red blood cell production as occurs in:

- Haemolytic anaemias (with effective erythropoiesis).
- Following acute blood loss
- After iron therapy for iron deficiency anaemia or specific therapy for megaloblastic anaemia

Reticulocyte responses are higher with haemolysis than haemorrhage.

*Decreased reticulocyte count:* Associated with ineffective erythropoiesis or decreased production of red cells.

---

#### **Heinz bodies in reticulocyte preparation**

Heinz bodies consist of altered (precipitated) haemoglobin caused by oxidative damage. They can be found in the red cells of patients with G6PD deficiency during a haemolytic crisis (see subunit 8.2), in some forms of thalassaemia, in conditions

associated with unstable haemoglobin, and following splenectomy.

#### *Appearance of Heinz bodies*

In reticulocyte preparations, Heinz bodies stain a lighter blue violet than the reticulin of reticulocytes and are usually seen as small granules lying close to the periphery of the cell or protruding through the cell membrane (see colour Plate 108). They vary in size from 1–3  $\mu\text{m}$  in diameter. Several Heinz bodies may be present in a single cell. If seen, report as 'Heinz bodies present'.

*Note:* Heinz bodies are best stained using isotonic crystal violet or methyl violet stain (0.5 g dissolved in 100 ml physiological saline). The staining method is the same as that described for staining reticulocytes.

### Haemoglobin H in reticulocyte preparation

Haemoglobin H ( $\beta_4$ ) is an unstable haemoglobin which can form in the red cells of patients with  $\alpha$  thalassaemia trait (small numbers of cells affected, i.e. up to 1%), and in patients with HbH disease (more than 10% of cells affected). HbH disease is described in subunit 8.2. Haemoglobin H inclusions are best stained using brilliant cresyl blue and the reticulocyte staining technique previously described but allowing 1 hour for staining.

#### *Appearance of Haemoglobin H inclusions*

Cells containing HbH are easily recognized by the many small pale blue granules they contain. The cells have been likened to golf balls. The appearance of HbH in a red cell is shown in colour Plate 106.

*Note:* Heinz bodies and the reticulin of reticulocytes, stain much darker than Haemoglobin H inclusions.

### Methaemoglobin reduction test

#### *Screening for G6PD deficiency*

**Value of test:** The methaemoglobin reduction test is one of the simpler and less expensive tests to screen for G6PD deficiency. As explained in subunit 8.2, reduced G6PD activity in red cells can cause acute intravascular haemolysis following exposure to oxidant agents or fava beans (favism), neonatal jaundice and less commonly, chronic haemolytic anaemia. The severity of clinical symptoms is mainly dependent on the variant of defective G6PD gene inherited. For the main laboratory findings associated with a haemolytic crisis, see subunit 8.2.

#### **Principle of test**

Haemoglobin is oxidized to methaemoglobin (Hi) by sodium nitrite. The redox dye, methylene blue activates the pentose phosphate pathway, resulting in the enzymatic conversion of Hi back to haemoglobin in those red cells with normal G6PD activity. In G6PD deficient cells there is no enzymatic reconversion to haemoglobin.

#### *Reagents*

- Methylene blue, 0.4 mmol/l Reagent No. 57
- Sodium nitrite-glucose reagent\*

\*The reagent must be prepared fresh on the day of use. To make 40 ml:

Sodium nitrite . . . . . 0.5 g  
Glucose . . . . . 2.0 g

Dissolve the chemicals in 40 ml of distilled (deionized) water.

#### **Preparation of reagents in tubes for long term storage**

To store the reagents in dried ready to use form:

- Mix equal volumes of methylene blue reagent with sodium nitrite-glucose reagent.
- Dispense in 0.2 ml amounts into small glass tubes.
- Dry the contents of the tubes at room temperature.
- Stopper the tubes and store in the dark at room temperature.

*Note:* In dried form the reagents are stable for up to 6 months.

**Blood sample:** EDTA anticoagulated venous blood is suitable. It should not be collected during a haemolytic crisis but when the patient has recovered and reticulocyte numbers have fallen back to normal levels. This is because reticulocytes contain higher levels of G6PD and may mask low G6PD activity in mature red cells. The blood must be tested within 8 hours of being collected. When the patient is anaemic, use a plasma reduced blood sample (remove sufficient plasma until the PCV is about 0.40).

#### **Test method**

- 1 Take 3 small glass tubes and label *Test, Normal, Deficient*.
- 2 Pipette into each tube as follows:

<i>Tube</i>	<i>Test</i>	<i>Normal control</i>	<i>Deficient control</i>
Sodium nitrite-glucose reagent (fresh)	0.1 ml	–	0.1 ml
Methylene blue reagent	0.1 ml	–	–
Patient's blood	2 ml	2 ml	2 ml

- 3 Stopper the tubes and mix well (gentle mixing). Incubate all three samples at 35–37°C for 90 minutes.
- 4 Take 3 large tubes (15 ml capacity) and label as described in step 1. Pipette 10 ml of distilled (deionized) water into each tube.
- 5 Transfer 0.1 ml of well mixed sample from the *Test*, *Normal*, and *Deficient* tubes to the large tubes. Mix the contents of each tube.
- 6 Examine the colour of the solution in each tube.

#### Interpretation of test results

Colour of test solution . . . . . Normal G6PD activity is similar to the red colour of the *Normal* tube

Colour of test solution . . . . . Reduced G6PD activity is similar to the brown colour of the *Deficient* tube (G6PD deficiency in homozygote)

*Note:* Results from a heterozygote are midway between normal G6PD activity and G6PD deficiency in the homozygote.

#### Quality control

Follow the technique exactly.

The main sources of error when performing the methaemoglobin reduction test are:

- Testing blood which has a high reticulocyte count or too low a haemoglobin concentration (see previous text).
- Not using freshly made sodium nitrite-glucose reagent.

## 8.10 Investigation of sickle cell disease

As explained in subunit 8.2, sickle cell disease is an inherited disorder which affects people from Africa, India, Middle East and the Mediterranean region, causing serious illhealth and high mortality especially in childhood. The main forms of sickle cell disease found in tropical countries are:

- *Homozygous sickle cell anaemia* (HbSS) in which a person inherits a haemoglobin S (HbS) gene from both parents. It is common in Africa, parts of India, the Middle East, and the Caribbean.
- *Sickle cell haemoglobin C* (HbSC) disease in which a person inherits HbS gene from one parent and HbC gene from the other. It is found in West Africa.
- *Sickle cell  $\beta$  thalassaemia* in which a person inherits HbS gene and one of the  $\beta$  thalassaemia genes. Clinically, HbS/ $\beta^0$  thalassaemia is the more severe form and is found in North Africa (and elsewhere). HbS/ $\beta^+$  thalassaemia is found mainly in West Africa and those of West African descent (e.g. Caribbean).
- *Sickle cell haemoglobin D<sup>Punjab</sup>* (HbSD<sup>Punjab</sup>) disease in which HbS is inherited with HbD<sup>Punjab</sup>. It is found amongst Sikh people.

#### Sickle cell trait

In sickle cell trait (HbAS) there is a heterozygous inheritance of HbS with HbA. The condition is asymptomatic with 30–40% of haemoglobin in the red cells being HbS and the remainder, normal haemoglobin. Under conditions of hypoxia, (low oxygen level) sickling may occur, e.g. when mountain climbing at high altitude, during prolonged anaesthesia, in severe pneumonia, or during prolonged intensive exercise (e.g. military training).

#### Haematological investigation of sickle cell disease

In district laboratories the following are the tests used to investigate suspected sickle cell disease and to identify sickle cell trait carriers (to assist in family counselling):

- Measurement of haemoglobin (see subunit 8.4).
- Sickle cell slide test to detect HbS in red cells.
- HbS solubility filtration test to differentiate sickle cell anaemia from other sickle cell disorders.
- Examination of a Romanowsky stained thin blood film for features associated with sickle cell disease.

*Haemoglobin electrophoresis:* When the tests performed at district level indicate that a person has a sickle cell disorder, this should be confirmed by haemoglobin electrophoresis in the nearest Haematology Reference Laboratory or Sickle Cell

Disease Centre. The principles of haemoglobin electrophoresis are described at the end of this subunit.

*Note:* Other tests may also be required e.g. bacteriological tests to investigate infections which are common in those with sickle cell disease, particularly those caused by *S. pneumoniae*, *Salmonella* species, *S. aureus*, *H. influenzae*, and *N. meningitidis*. Children with sickle cell disease can also develop severe falciparum malaria with complications (sickle cell trait carriers are partially protected against severe falciparum malaria, see subunit 8.2).

### Sickle cell slide test

*Value:* This test is simple to perform and requires only a single reagent. It does not however, differentiate between sickle cell disease and sickle cell trait. It is useful when it is not possible to perform the HbS solubility filtration test.

#### Principle of test

Blood is mixed on a slide with a chemical reducing agent such as sodium metabisulphite (*di*-sodium disulphite) or sodium dithionite, covered with a cover glass, and incubated at room temperature for up to 1 hour or more. The reducing agent deoxygenates the haemoglobin in the red cells providing the conditions for cells containing HbS to sickle.

#### Reducing reagent

Freshly made 20 g/l (2% w/v) sodium metabisulphite\* or sodium dithionite solution.

\*Also referred to as *di*-sodium disulphite.

- Weigh 0.2 g of the chemical and transfer to a tube or bottle of 15 ml capacity.

*Note:* To avoid the need to weigh the chemical each time, use a *small* diameter tube, premarked to hold 0.2 g. Keep this attached to the bottle of chemical with an elastic band.

- Add 10 ml of distilled or deionized water (or when unavailable, boiled filtered rain water), stopper, and mix until the chemical is fully dissolved.

*Note:* The chemical is unstable. It can be used only on the day it is prepared (up to 8 hours).

#### Test method

- 1 Deliver one drop of patient's capillary blood or well mixed venous blood on a slide (marked P). Add an *equal* volume of fresh reducing reagent, mix, and cover with a cover glass. Exclude any air bubbles.

*Note:* When the patient is severely anaemic, use 2 drops of blood or preferably use a plasma reduced blood sample.

- 2 Set up a *Negative Control*: Deliver one drop of blood from a person that does not have a sickle cell disorder on a slide marked 'Neg Control'. Add an *equal* volume of fresh reducing reagent and mix. Cover with a cover glass. Exclude any air bubbles.

If a blood from a known sickle cell trait person is available, set up also a *Positive Control*.

- 3 Place the slides in a container (plastic box or petri dishes) with a damp piece of blotting paper or tissue in the bottom to prevent drying of the preparations. Close the container and leave at room temperature.
- 4 After 10–20 minutes, examine the patient's preparation microscopically for sickle cells. Focus the cells first with the 10× objective and examine for sickling using the 40× objective.

Examine several parts of the preparation. Sickling often occurs quicker in one area than the other.

A positive sickle cell test is shown in Plate 8.7 and colour Plate 100. The sickle cells may appear crescent shaped with pointed ends or holly leaf shaped, especially in sickle cell trait.

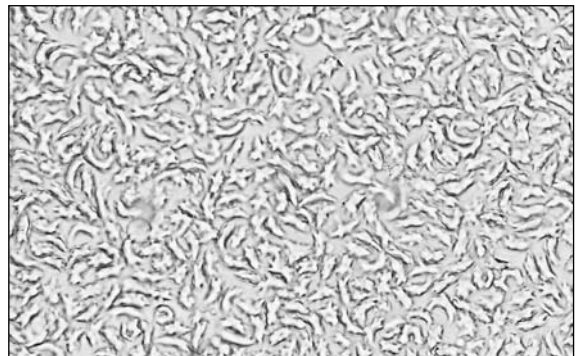

Plate 8.7 Positive sickle cell slide test.

*Haemolyzed preparation:* If haemolysis of the red cells occurs, this usually indicates that the reagent is too concentrated or too much reagent has been used (usually the control preparation will also be haemolyzed). Repeat the test with freshly made reagent.

When the preparation is negative, examine it again after 1–2 hours\*.

- 5 Report the patient's preparation as 'Sickle cell test positive', or Sickle cell test 'negative'.

*Note:* The Negative Control preparation should show no sickle cells.

#### Quality Control

Always set up a Negative Control and whenever possible also a Positive Control using blood from a person with sickle cell trait.

The main sources of error when performing a sickle cell slide test are:

- Not using the reducing agent at the correct concentration or using too much reagent to the volume of blood.
- Using reagent that is more than 8 hours old.
- Not using a clean slide or clean cover glass.

#### Interpretation of test result

A positive sickle cell test indicates that a person's red cells contain HbS. A stained blood film and clinical history may enable sickle cell disease to be differentiated from sickle cell trait. Blood (haemolysate) should be sent for haemoglobin electrophoresis to confirm the disorder (see later text).

The test is not sufficiently sensitive to detect very small amounts of HbS which may be present in the blood of infants (below 6 months of age). When a patient has been transfused, the test should be performed after 1–2 months to obtain a reliable result.

#### HbS solubility filtration test

*Value:* When reagents are available, this test should be performed in preference to the sickle cell slide test because it provides information about the different sickle cell disorders. In areas where both HbS and HbD occur this test can be used to differentiate sickle cell anaemia (HbSS) from HbSD sickle cell disease.

#### Principle of the test

Blood is mixed in a phosphate buffer-saponin solution containing sodium dithionite and filtered. In its deoxygenated form, HbS is insoluble. HbSS is indicated by a red precipitate on the filter paper with a pale yellow filtrate. Other forms of haemoglobin are soluble when in a reduced state.

#### Reagents

- Phosphate buffer-saponin pH 7.1 Reagent No. 67  
Store at 2–8 °C. Renew every 3 months or if it becomes turbid.
- Sodium dithionite powder.

To make the working reagent:

- Measure 20 ml of buffer-saponin solution.
- Add 0.2 g sodium dithionite and mix gently until the chemical is dissolved.

*Note:* The working reagent is not stable. It can be used only on the day it is prepared.

#### Test method

Set up with the test, a negative control (HbAA) and a positive control using blood from a person with sickle cell trait (HbAS).

- 1 Pipette 2 ml of working reagent into a test tube approximately 13 × 77 mm.
- 2 Wash in 100 µl (0.1 ml) of capillary blood or well mixed venous blood.  
*Note:* When the haemoglobin is below 70 g/l (7 g/dl), use twice the volume of blood or if a venous blood sample, use plasma reduced blood (remove about half the plasma).
- 3 Mix well and filter through a small (5.5 cm diameter) No. 1 filter paper.
- 4 Note the colour of the solution (pale yellow, pink-red, or dark red) and whether there is any red precipitate (insoluble reduced HbS) on the filter paper.

#### Results after filtration (see colour Plate 101)

HbSS . . . . . Clear pale yellow filtrate. Abundant red precipitate on filter paper

HbAS . . . . . Clear pink filtrate. Small amount of red precipitate on filter paper\*

\*Same result will be obtained with HbSC and HbS with other Hb variant

HbAA (normal) . . . . . Dark red fluid (soluble reduced Hb) with no precipitate on filter paper\*

\*Same result will be obtained with HbAC and HbAD

*Note:* The results of the HbS solubility filtration test are shown in colour Plate 101.

- 5 Report the HbS solubility filtration test as:
  - 'Positive for sickle cell anaemia' when result shows HbSS appearance.
  - 'Positive for sickle cell haemoglobin' when result shows HbAS appearance.

*Note:* In West Africa, this result could also indicate HbSC disease or HbS<sup>β</sup> thalassaemia. The blood film



and clinical history will help to differentiate these conditions.

- ‘Negative for HbS’ when result shows HbAA appearance.

*Note:* Confirm the test results by haemoglobin electrophoresis (see later text) and also examine a Romanowsky stained blood film. A false negative solubility test may occur when there is interaction of alpha-thalassaemia trait and  $\beta^S$  genes in sickle cell trait (due to decreased HbS).

#### Testing blood from infants below 6 months

When the HbS solubility test is performed as described above the technique is too insensitive to detect HbS in infants below 6 months. Hall & Malia recommend\* examining microscopically a drop of the blood-working reagent mixture instead of filtering it. Cells containing HbS will be seen as intact red cells (containing insoluble HbS). Cells not containing HbS will appear as ‘ghost’ (empty) cells. Precipitated plasma proteins appear as amorphous material.

\*Hall R., Malia R.G. *Medical Laboratory Haematology*, 2nd edition, 1991. Butterworth Heinemann.

#### Quality control

Set up a ‘Negative Control’ using blood from a person without a sickle cell disorder. Also set up a ‘Positive Control’ using blood from a person with sickle cell trait.

Sources of error associated with the HbS solubility filtration test include:

- Using a reagent that has deteriorated. If after adding blood to the working reagent, a pale orange colour develops, this indicates reagent deterioration. A fresh reagent must be prepared.
- Using blood with too few red cells. Either the volume of blood used should be increased or preferably the test performed on a plasma reduced blood sample.
- Testing the blood of a transfused patient. The test should be performed at a later date to obtain a reliable test result.

#### Examination of a stained thin blood film

A patient with sickle cell disease (usually a child) will be anaemic (Hb 60–90 g/l) and show the clinical features as described in subunit 8.2. The blood film will show:

- Marked poikilocytosis and polychromasia (due to reticulocytosis) with sickle cells which will be particularly prominent in a haemolytic crisis.
- Target cells and nucleated red cells.

- Sometimes macrocytosis with hypersegmented neutrophils when there is accompanying folate deficiency.

Howell-Jolly bodies may be present when the spleen is non-functional together with many target cells. Platelet numbers may be increased following a sickle cell crisis.

*Note:* A blood film from a child with sickle cell disease is shown in colour Plate 99.

#### Thick blood film appearance in sickle cell disease

Although the red cells are haemolyzed when a thick blood film is stained, the reticulin from reticulocytes and nuclei from nucleated red cells remain. Sickle cell disease should be suspected when a thick blood film from a child shows marked blue stippling in the background (see colour Plate 102).

## HAEMOGLOBIN ELECTROPHORESIS

Haemoglobin electrophoresis is used to separate and identify the different haemoglobins by their migration within an electric field. Haemoglobin variants separate at different rates due to differences in their surface electrical charge as determined by their amino acid structure.

#### Alkaline cellulose acetate electrophoresis

Several techniques are available to separate haemoglobin variants by electrophoresis. For routine work, electrophoresis in an alkaline buffer at pH 8.4–8.6 using a cellulose acetate membrane is adequate.

This gives good separation of HbA, HbF, HbS, and HbC. On alkaline electrophoresis HbD and HbS have the same mobility and HbC, HbE and HbO also co-migrate. In specialist laboratories agarose gel electrophoresis at an acid pH (6.0) can be used to separate these haemoglobins and also to provide a clear separation of HbF from HbS and HbC.

#### Equipment

Most recently developed equipment for cellulose acetate alkaline electrophoresis is designed for use with plastic supported (*Mylar*-backed) cellulose acetate membranes. Such equipment is not suitable for use with unsupported (non-*Mylar*-backed) cellulose acetate membranes. Unsupported cellulose acetate membranes are becoming increasingly difficult to obtain\* as more laboratories change to using *Mylar*-backed membranes because they provide rapid separation of the different abnormal haemoglobins and HbA<sub>2</sub> with greater resolution.

\*A source of unsupported cellulose acetate membranes is Sartorius AG (see Appendix 11). The membranes measure  $78 \times 150$  mm, code No. SM 12200-78  $\times$  150K and are packaged 50 per box. These membranes can be used in older electrophoresis tanks.

Equipment for performing alkaline cellulose acetate electrophoresis using *Mylar*-backed supported cellulose acetate membranes is available from Helena BioSciences (see Appendix 11). The essential components are:

- An electrophoresis chamber (tank), model *Zip Zone Chamber* (Cat. No. 1283) as shown in Plate 8.8(a).

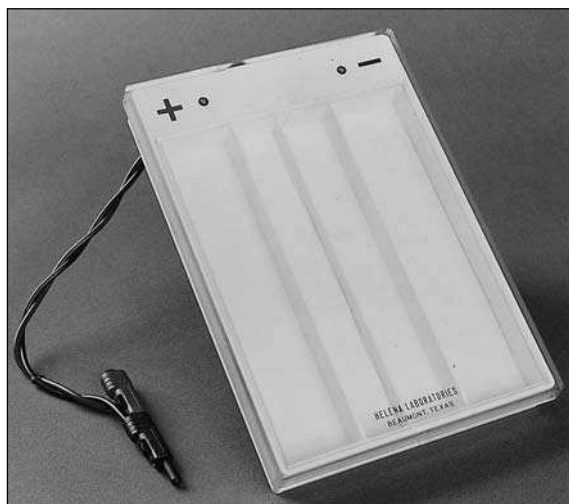

Plate 8.8(a) Helena BioSciences *Zip Zone* electrophoresis chamber suitable for alkaline cellulose acetate haemoglobin electrophoresis.

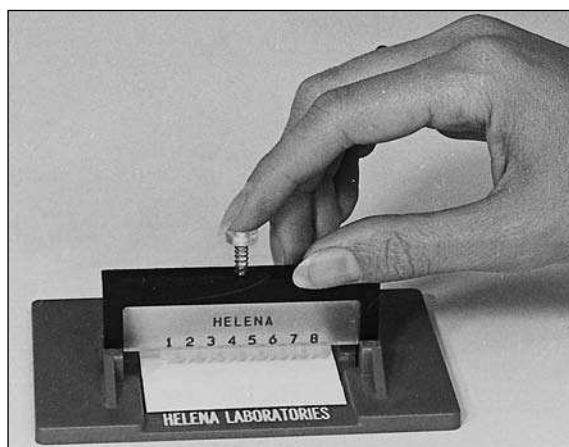

Plate 8.8(b) Applicator system used with the *Zip Zone* electrophoresis chamber. Courtesy of Helena BioSciences.

- A regulated Power Supply capable of delivering 350 V 50 mA is required for cellulose acetate haemoglobin electrophoresis. An example of a suitable Power Supply is the model EV 243 variable voltage Power Supply available from Helena BioSciences. It is shown in Plate 8.9.



Plate 8.9 EV 243 Power Supply suitable for cellulose acetate haemoglobin electrophoresis with integral digital timer.

- Accessories for applying the samples, including:
  - *Zip-Zone* 8 unit applicator (Cat. No. 4080)
  - *Zip-Zone* well plate (Cat. No. 4081)
  - *Zip-Zone* aligning base (Cat. No. 4082)

#### *Cellulose acetate (Mylar-backed) membranes\**

\*Referred to by Helena BioSciences as *Titan 111-H Acetate plates* (Cat. No. 3022), they are designed for use in the *Zip-Zone* electrophoresis chamber.

*Titan 111-H acetate plates* (membranes) measure  $60 \times 76$  mm. Each membrane is sufficiently wide for 8 samples to be applied. They are supplied 25 membranes (plates) per box.

#### *Reagents*

Tris-EDTA-borate buffer, pH 8.5 Reagent No. 86  
Keep refrigerated at 4–8 °C. It has good stability.

#### *Controls*

Controls should include the following haemolysates:

- HbAA: Normal adult blood
- HbAS: Blood from a person with sickle cell trait
- HbAF: Blood from an infant below 3 m
- HbAC: Blood from a person with HbC trait (when HbC is found locally)

Control haemolysates should be prepared from HIV and hepatitis HBsAg negative persons (see end of

subunit). When stored at 4 °–8 °C they are stable for several weeks and when stored frozen they can be kept for several months.

*Note:* Various controls for haemoglobin electrophoresis are also available from Helena BioSciences (*Hemo Controls*), e.g. *Hemo Hb A, F, S, A<sub>2</sub>, Hemo Hb A, A<sub>2</sub>, Hemo A, F, S, C, and Hemo A, S, A<sub>2</sub>*.

### Method

The procedure for performing alkaline cellulose acetate haemoglobin electrophoresis using Helena BioSciences equipment and *Mylar*-backed supported cellulose acetate membranes (*Titan 111 cellulose acetate plates*) is supplied with the membranes. The following is a summary of the method used to separate the different haemoglobins (e.g. Hb A, F, S, and C), excluding staining and densitometry to quantitate the relative percentage of each haemoglobin band\*.

\*Staining is required when a permanent record of the results of haemoglobin electrophoresis is required. When using *Mylar*-backed cellulose acetate membranes, separation of the different haemoglobins is rapid and clear, enabling results to be read visually without the need for staining. Furthermore, some laboratories have found that they can reuse membranes by allowing the original samples to 'run off'. Quantifying the different haemoglobin bands may be indicated in certain haemoglobin disorders. It requires use of a clearing agent, drier, and densitometer (available from Helena BioSciences).

- 1 Prepare the cellulose acetate membrane (*Titan 111 cellulose acetate plate*) exactly as described in the Helena BioSciences procedure.
- 2 Pour 100 ml of the Tris-EDTA-borate buffer into each of the outer sections of the *Zip-Zone* electrophoresis chamber.
- 3 Wet two wicks (as supplied) in the buffer and drape one over each support bridge, ensuring each makes contact with the buffer and that there are no air bubbles under the wicks. Cover the chamber to prevent evaporation.
- 4 Transfer 5 µl of each haemolysate sample (tests and controls) into the *Zip-Zone* well plate.
- 5 Place a cellulose acetate membrane (plate) in the *Zip-Zone* aligning plate and apply the samples using the 8 unit applicator *exactly* as described in the Helena BioSciences procedure.
- 6 Immediately place the cellulose acetate membrane (plate) in the electrophoresis chamber, *cellulose acetate side down*.

- 7 Connect the chamber to the Power Supply and electrophorese the plate for 25 minutes (or shorter) at 350 volts and 50 mA.

*Note:* To economize, some laboratories apply a second row of samples to the membrane (about half-way down). When this is done, more careful attention must be paid to timing the 'run'. As soon as the controls and samples show adequate clear to read separations, electrophoresis can be stopped.

### Results

The relative mobilities of haemoglobins A, F, S, D, E, C and H after alkaline electrophoresis are shown in Plate 8.10(a). In alkaline buffer, HbS and HbD have similar mobility and HbC, HbA<sub>2</sub>, HbE, and HbO have similar mobility. Separation of some haemoglobins on a *Titan 111 cellulose acetate plate* are shown in Plate 8.10(b). Acid citrate agar electrophoresis can help to differentiate some of the haemoglobins which co-migrate.

**HbG<sup>Philadelphia</sup>:** This alpha globin abnormal haemoglobin is found in Africans and may cause confusion when interpreting electrophoresis test results. HbAA + HbG<sup>Phil</sup> looks like HbAS on electrophoresis. With HbAS + HbG<sup>Phil</sup>, the hybrid molecule S/G has a mobility similar to HbC. HbSS + G<sup>Phil</sup> looks like HbSC from which it may be distinguished by the solubility test which gives an HbSS result.

### Preparation of haemolysate from EDTA anticoagulated blood

*When testing a haemolysate within 1–2 days*

Lyze 1 volume of saline washed packed red cells in 4 volumes of lyzing reagent\*.

#### \*Lyzing reagent

Dissolve 3.8 g EDTA (ethylenediamine tetra-acetic acid) and 0.7 g potassium cyanide in 1 litre of distilled water.

*Caution:* Potassium cyanide is highly poisonous, therefore handle it with great care. It must be stored in a locked cupboard.

*For long term storage of haemolysate*

- 1 Centrifuge the sample, remove the plasma, and wash the red cells three times in physiological saline. After each wash, centrifuge the cells at about 1 000 g for 5 minutes. Remove the saline.
- 2 Lyze the red cells with 1.5 volumes distilled (deionized) water and 1 volume of toluene or carbon tetrachloride. Shake well for several minutes in a stoppered tube or preferably vortex at high speed for 1 minute. Centrifuge at about 1 000 g for 20 minutes.

*Caution:* Carbon tetrachloride and toluene are

toxic chemicals, therefore handle them with care. Toluene is also flammable, therefore use it well away from an open flame.

- Transfer the clear supernatant haemolysate into a tube. Adjust the haemoglobin content to about 100 g/l (10 g/dl) by adding distilled water. Label clearly.

*Note:* The haemolysate will be stable for several weeks at 4–8°C and for up to 3 months when stored frozen.

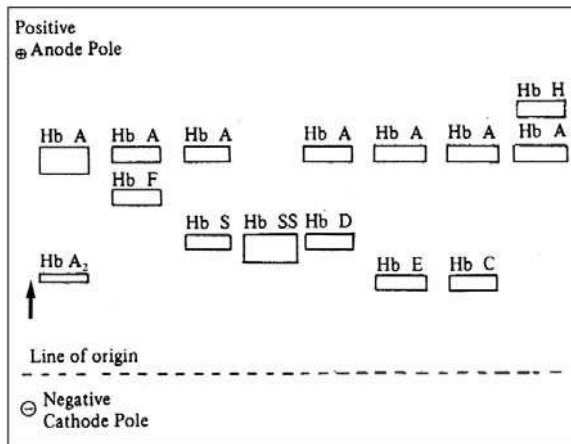

Plate 8.10(a) Separation of haemoglobins by electrophoresis at alkaline pH. *Note:* HbS and HbD have the same mobility but can be differentiated by a sickle cell test. HbE and C also co-migrate but the global distribution of these two haemoglobins is different.

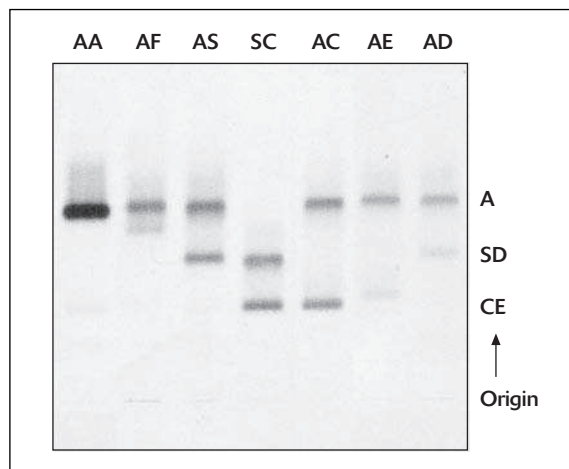

Plate 8.10(b) Separation of haemoglobins on Mylar-backed cellulose acetate membrane (plate) by alkaline electrophoresis. *Courtesy of Helena BioSciences.*

## 8.11 Investigation of bleeding disorders

Abnormal bleeding may be caused by:

- damage to vascular endothelium
- reduction in platelet numbers
- defective platelet function
- disorders of blood coagulation

- *Damage to vascular endothelium, reduction in platelet numbers, or defective platelet function:* Can result in purpura with bleeding from or into superficial tissues, e.g. mucous membranes.

### Vascular endothelial damage

In tropical countries, the main causes of vascular endothelial damage are infections which cause toxic or immune damage to endothelial cells as in viral haemorrhagic fevers and Gram negative septicaemias. Other causes include drugs, herbal remedies, and snake envenomation.

### Thrombocytopenia

This may occur when platelet production is reduced or when there is an increase in the consumption or destruction of platelets as described in subunit 8.6.

### Defective platelet function

This may occur as a complication of viral haemorrhagic fevers, liver cirrhosis, alcoholism, leukaemias, paraproteinaemias, uraemia and treatment with certain drugs (e.g. aspirin and nonsteroidal anti-inflammatory drugs).

### Laboratory investigation

- Haemoglobin test (see subunit 8.4)
- Blood film report (see subunit 8.7)
- Platelet count (see subunit 8.6)
- Bleeding time test\*

\***Bleeding time test:** This is a sensitive test of endothelial and platelet function and platelet numbers. In tropical countries, the commonest causes of prolonged superficial bleeding are infections, herbal remedies, taking aspirin and particularly thrombocytopenia. Details of how to perform a bleeding time test can be found in the booklet *The bleeding and clotting disorders* (see *Further Reading* and publication *Practical Haematology*, 9th edition, 2001, Churchill Livingstone/Elsevier).

*Note:* Specialist laboratory facilities are required to test for abnormal platelet function.

- *Disorders of blood coagulation:* Can result in uncontrolled haemorrhaging into joints, muscles and deep tissues with the formation of haematomas. Coagulation disorders may be:

- Hereditary, as in haemophilia A due to a deficiency of clotting factor VIII (commonest hereditary coagulation disorder), haemophilia B (Christmas disease) due to a deficiency of

factor IX, and Von Willebrand's disease caused by a deficiency or abnormality of the von Willebrand factor resulting in a defect in platelet adhesion. Haemophilia is carried by the female and affects males.

- Acquired coagulation disorders as in vitamin K deficiency, severe liver disease, and disseminated intravascular haemolysis (DIC) associated with infections, obstetric complications (septic abortion, eclampsia, fetal retention, ruptured uterus), haemorrhagic disease of the newborn, snake envenomation, and malignancies. Also overdose of anticoagulant drugs, e.g. warfarin.

#### Laboratory investigations

- Activated partial thromboplastin time (APTT).
- Prothrombin time (PT). This test is also used in monitoring patients being treated with warfarin oral anticoagulant.
- Thrombin time (TT) test.

*Note:* Specialist laboratory facilities are required to perform clotting factor assays and other coagulation tests to diagnose and control hereditary coagulation disorders such as haemophilia and to investigate rare coagulation disorders.

### Blood coagulation

To understand blood coagulation tests it is helpful to have a basic understanding of the role of the different blood clotting factors and the coagulation process.

The coagulation process is a complex series of enzymatic reactions involving the proteolytic activation of circulating coagulation factors (zymogens) and activity of co-factors (V, VIII), leading to the production of thrombin which converts soluble plasma fibrinogen into fibrin (as represented diagrammatically in Fig. 8.11). The fibrin enmeshes the platelet plug, forming a stable thrombus which prevents further blood loss from the damaged vessel.

#### Extrinsic and intrinsic pathways

The terms intrinsic and extrinsic have traditionally been used in describing the clotting process in the classical blood coagulation theory. It is now known that the intrinsic pathway (involving factor XII and kallikrein) is of importance in the *in vitro* process (laboratory tests), but is less significant in the *in vivo* (in the body) clotting process.

The intrinsic pathway *in vivo* begins with the activation of factor IX by factor VIIa. Factor XI *in vivo* is activated by thrombin, calcium and the co-factor HMWK (high molecular weight kininogen). In the test tube, the initiation of clotting via the intrinsic system begins with the activation of factor XII when it is exposed to the glass surface. The clotting sequence is shown in Fig. 8.11.

### Blood clotting factors, their source and function

Factor	Source and function
Fibrinogen* I	Plasma protein made in the liver. Converted to fibrin.
Prothrombin* II	Plasma protein, made in the liver with help of vitamin K. Converted to thrombin.
Tissue factor* (thromboplastin) III	Released from damaged tissue. Essential in activating <i>in vivo</i> coagulation.
Calcium ions* (Ca <sup>2+</sup> ) IV	Inorganic ions in plasma, derived from diet or bone. Essential for the coagulation process.
V Labile factor	Plasma protein, made in the liver. Also released from platelets. Co-factor involved in converting prothrombin to thrombin.
<i>Note: There is no factor VI</i>	
VII Proconvertin or Stable factor	Plasma protein, made in the liver with the help of vitamin K. <i>In vivo</i> , activates factor IX.
VIII Antihæmophilic factor	Globulin made in the liver (deficiency causes hæmophilia A). Co-factor, involved in activating factor X.
IX Christmas factor	Plasma protein made in the liver with the help of vitamin K (deficiency causes hæmophilia B). Involved in activating factor X.
X Stuart-Power factor	Plasma protein made in the liver with the help of vitamin K. Involved in converting prothrombin to thrombin.
XI Plasma thromboplastin antecedent	Plasma protein made in the liver. <i>In vivo</i> , activated by thrombin and factor XII and important at major sites of trauma.
XII Hageman (glass, or contact) factor	Plasma protein made in the liver. Involved in converting plasminogen to plasmin and activating factor XI in fibrinolysis. <i>In vitro</i> (laboratory tests), it initiates the clotting process.
XIII Fibrin stabilizing factor	Plasma protein made in the liver and present in platelets. Converts fibrin polymer to stable insoluble fibrin.

\*Factor known by name, other factors are usually referred to by their Roman numeral.

*Note:* Vitamin K dependent factors are prothrombin, VII, IX, X.

### Performing coagulation tests in district laboratories

Most patients with serious coagulation disorders are investigated and treated in specialist centres. Screening for acquired coagulation disorders and monitoring patients receiving oral anticoagulation therapy are sometimes carried out in the more comprehensive district and regional laboratories when there is a clear need, staff have been adequately trained, and standardized reagents and control plasma are available from a Reference Coagulation Laboratory or elsewhere. In this subunit the following screening tests using manual procedures are described:

- Activated partial thromboplastin time (APTT)
- Prothrombin time (PT)
- Thrombin time (TT)

*Important:* When a test method is supplied with a particular reagent from a Reference Laboratory, the procedure supplied must be followed.

*Note:* The information provided by APTT, PT and TT tests and a platelet count is summarized in Chart 8.7 at the end of this subunit. Test results must be interpreted with a knowledge of the patient's medical history, clinical symptoms, recent and present treatment.

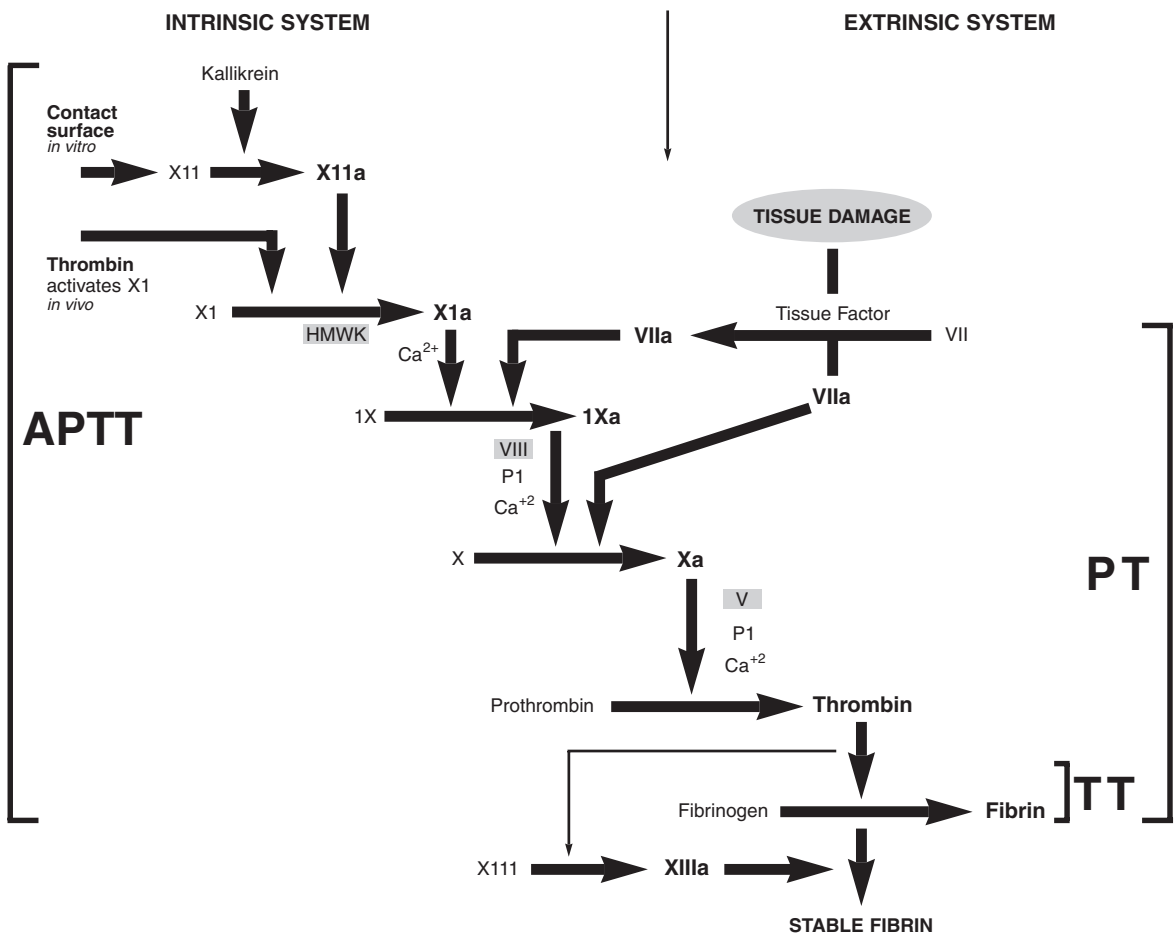

Fig 8.11 Diagrammatic representation of blood coagulation. The letter 'a' after a factor indicates activation of factor. *Note:* Kallikrein and factor XI reactions are relevant in *in vitro* testing. *In vivo*, the intrinsic system begins with the activation of factor IX by factor VIIIa. *In vivo*, thrombin also activates factor XI. HMWK, V, and VIII are co-factors. P1 = Platelet phospholipid. APTT = Activated partial thromboplastin time test. PT = Prothrombin time test. TT = Thrombin time test.

### Activated partial thromboplastin time (APTT) test

The APTT is a screening test of the intrinsic clotting system. It will detect the inhibition or deficiency of one or more of the following factors: prothrombin, V, VIII (antihæmophilic factor), IX, X, XI, XII and fibrinogen. The APTT is also used to monitor patients being treated with heparin.

#### Principle of test

Kaolin (surface activator) and platelet substitute (phospholipid) are incubated with citrated plasma at 37°C for the time specified in the test method. Calcium chloride (CaCl<sub>2</sub>) is added and the time taken for the mixture to clot is measured.

#### Reagents

- Kaolin/platelet substitute mixture\*

\*Purchase from a reliable manufacturer in lyophilized form and reconstitute as instructed.

**Availability:** *Kaolin/platelet substitute mixture* is available from Diagnostic Reagents Ltd (see Appendix 11). Each pack contains 6 × 5 ml vials (sufficient for 150 tests). Each vial is reconstituted in 5 ml of distilled water (also available from Diagnostic Reagents upon request). The suspension is stable for at least 2 weeks at 4–8°C. Do not freeze.

- Calcium chloride, 0.025 mol/l (25 mM)\*

\*This is best obtained ready made unless the laboratory has facilities to make the reagent accurately and standardize it. The reagent is available from Diagnostic Reagents (bottle of 250 ml) and other suppliers.

#### Control plasma

A normal control plasma must be run with each batch of tests. Obtain from the nearest Coagulation Reference Laboratory or purchase from a reliable manufacturer. The control plasma should be pre-screened for HIV, HBsAg and HCV.

**Availability:** Pre-screened control plasma is available from Diagnostic Reagents Ltd and other suppliers. The *Diagen Normal Reference Control Plasma* (multipurpose, giving values for APTT, PT and TT tests) is available in a pack of 6 × 0.5 ml vials. It requires reconstitution in distilled water. When reconstituted it is stable for several months when stored frozen at –20°C (in volumes required for the different tests).

#### Equipment

- Water bath at 37°C (see p. 151 in Part 1 of the book).
- Stop-watch.

**Blood specimen:** Collect 9 ml of venous blood (well taken with minimum of stasis) into a plastic tube containing 1 ml of aqueous tri-sodium citrate anticoagulant, 32 g/l (see Reagent No. 73). Mix the blood well with the anticoagulant. Without delay, centrifuge the blood at 1 200 g–2 000 g for 15

minutes. This will provide platelet poor plasma. Immediately remove the plasma into a plastic tube (vial) and stopper. If a delay in performing the APTT is unavoidable, refrigerate the sample at 4–8°C. The test should be performed within 1 hour of collecting the blood.

#### APTT test method

Test the control plasma and patient's plasma in duplicate.

#### Method using Kaolin/Platelet substitute mixture

- 1 Pipette 0.2 ml of well-mixed kaolin/platelet substitute in a small glass tube.
- 2 Add 0.1 ml of plasma, mix, and incubate at 37°C for *exactly* 2 minutes (tilting the tube at intervals).
- 3 Add 0.1 ml 0.025 mol/l calcium chloride, mix and start the stop-watch. Hold the tube in the water bath and tilt the mixture back and forth, looking for clot formation. When a clot forms, stop the stop-watch and record the time.
- 4 Report the patient's APTT (average of the duplicate tests) providing the APTT of the normal control plasma is satisfactory.

#### Reference APTT range

Normal plasma clots in 36–50 seconds (using the method previously described).

Causes of a prolonged APTT include:

- DIC (involving several clotting factors)
- Deficiency of clotting factors: prothrombin, V, VIII, IX, X, XI or XII due to vitamin K deficiency, liver disease, heparin or warfarin anticoagulation, or less commonly an inherited coagulation disorder (see previous text).

Plasma samples completely deficient in factors VIII or IX, give clotting times of around 120 seconds.

*Note:* For an interpretation of test results, see also Chart 8.7 at the end of this subunit.

#### Screening for a circulating anticoagulant (inhibitor)

When there is a prolonged APTT and the patient is not being treated with anticoagulants, it is important to check that the prolonged APTT is not due to a circulating anticoagulant. To do this, repeat the test using a mixture of patient's plasma with normal plasma (i.e. 50 µl patient's plasma, mixed with 50 µl control plasma) which has been pre-incubated at 37°C for 2 hours. If the test result is within the reference range, this indicates a deficiency of one or more clotting factors. If the APTT is still prolonged, the patient may have a circulating anticoagulant.

### Quality control

Always perform the patient's test in duplicate and always test a control plasma (in duplicate).

### Sources of error when performing APTT tests (also PT and TT tests)

- Difficulty in obtaining a venous sample, resulting in haemolysis or small clots in the sample.
- Delay in testing the plasma and leaving the sample at room temperature.
- Using tubes or pipettes which are not clean and dry or are contaminated with detergent. Whenever possible use disposable tubes.
- Not timing accurately the different stages of the test (a stop-watch *must* be used).
- Using unsatisfactory reagents (will be detected when testing control plasma).
- Not pipetting correct volumes of plasma and reagents.
- Reconstituting reagents and control plasma with contaminated deionized water. This is a common cause of incorrect coagulation tests (usually shorter times are obtained). Whenever possible, fresh distilled water should be used (see subunit 4.4 in Part 1 of the book). Preventing the contamination of deionized water is discussed on pp. 129–131 in Part 1 of the book. When it is not possible to obtain good quality water, purchase distilled water from a pharmacy or manufacturer of the coagulation reagents being used.

### Prothrombin time (PT) test

The PT is a screening test for the extrinsic clotting system, i.e. factor VII. It will also detect deficiencies of factors, prothrombin, V, X, and fibrinogen. It is mainly used to monitor patients receiving warfarin anticoagulation.

#### Principle of the test

Plasma or capillary blood is added to a thromboplastin and calcium chloride reagent at 37°C and the time taken for a clot to form is measured. The clotting time in seconds is converted to the International Normalized Ratio (INR), usually by reference to a table provided by the manufacturer of the reagent or from the formula.

$$\text{INR} = \left( \frac{\text{PT Patient}}{\text{PT Control}} \right)^{\text{ISI}^*} \text{ i.e. prothrombin ratio to the power of the ISI}$$

\***International sensitivity Index:** This figure is provided by the manufacturer of the thromboplastin reagent. To obtain the INR, calculate the prothrombin ratio, log the ratio, multiply by the ISI, and antilog the result.

### Reagents

Thromboplastin calcium chloride combined reagent.

*Note:* Several different thromboplastin calcium combined reagents are available depending on the source of the thromboplastin and whether the test is to be performed using plasma or capillary whole blood. Some manufacturers supply a thromboplastin calcium reagent that can be used with both capillary blood and plasma.

**Capillary blood PT testing:** This avoids the need to collect venous blood when monitoring patients being treated with warfarin. It should not be used however when a patient is anaemic or polycythaemic. Plasma should then be used.

**Availability:** Lyophilized thromboplastin/calcium chloride reagent that can be used to perform a PT using either plasma or capillary blood is available from Diagnostic Reagents Ltd (see Appendix 11). It is called *Diagen rabbit brain capillary reagent* and is available in a pack of 6 × 5 ml vials. In lyophilized form the reagent is stable for 3 y. After reconstitution it is stable for 2–3 days at 4–8°C. Do not freeze.

**Important:** When the *Diagen* reagent is used to test capillary blood it is reconstituted in distilled water. When it is used to test plasma it is diluted in 0.006 mol/l (6 mM) calcium chloride solution (available from Diagnostic Reagents Ltd).

**Equipment:** As described previously for APTT test.

**Blood specimen:** Use free-flowing capillary blood or collect and centrifuge venous blood as described previously for the APTT test. Do *not* however refrigerate the venous blood or plasma. Perform the PT test as soon as possible after collecting the blood.

#### Control plasma

Obtain locally or use the *Diagen Normal Reference Control Plasma* described previously for the APTT test. Alternatively, use the *Rabbit Brain Capillary Reagent Normal Control Plasma* (also supplied by Diagnostics Reagents Ltd).

#### PT test method

If using patient's plasma, test in duplicate. Test the control plasma in duplicate. The following capillary blood method is based on using *Diagen Rabbit Brain Capillary Reagent*

- 1 Pipette 0.25 ml of the thromboplastin/calcium reagent into a small glass tube. Place in a 37°C water bath for 1–2 minutes.
- 2 Using a calibrated capillary or delivery pipette, add 50 µl (0.05 ml) of capillary blood or plasma, mix, and start the stop-watch. Hold the tube in the water bath and tilt the mixture back and forth looking for clot formation. When a clot forms, stop the stop-watch and record the time in seconds.



- 3 Convert the clotting time to the INR using the table provided by the manufacturer. Separate INR tables are provided for capillary blood and plasma.

*Note:* The INR conversion table provided by the manufacturer is specific for the batch of thromboplastin supplied with it.

#### Reference PT range

Normal plasma samples (patients not on anticoagulant) clot in 11–16 seconds. Each laboratory should establish its own normal reference range. Main causes of a prolonged PT test are:

- Treatment with oral anticoagulant drugs (vitamin K antagonists) such as warfarin.
- Liver disease
- DIC
- Haemolytic disease of the newborn
- Rarely a deficiency of factor VII, X, V, or prothrombin.

*Note:* When the INR is greater than 5.0, spontaneous bleeding may occur. Patients receiving warfarin anticoagulation should be made aware of conditions, drugs, and foods which may increase or decrease the effects of warfarin.

*Quality control:* This is as described previously for APTT tests.

#### Coagucheck S meter

This is a hand-held easy to use reflectance meter, available from Roche Diagnostics (see Appendix 11), which provides INR and PT results within 1 minute of applying a 10  $\mu$ l capillary or venous blood sample. It operates from mains electricity using an adaptor or from 4 AA batteries.



Plate 8.11 *Coagucheck S meter* to determine INR and prothrombin time.

#### Thrombin time (TT) test

The TT test is sensitive to a deficiency of fibrinogen or inhibition of thrombin. It measures the formation of a fibrin clot by the action of thrombin on fibrinogen.

##### Principle of test

Thrombin is added to citrated plasma at 37°C. The time taken for the mixture to clot is measured and the appearance of the clot noted.

##### Reagent

The use of a thrombin time test kit is recommended. This provides the correct concentration of thrombin to use in the test, i.e. that which gives a clotting time of 12–15 seconds with pooled normal plasma.

**Availability:** A TT test kit is available from Diagnostic Reagents Ltd (see Appendix 11) and other suppliers. The *Diagen Thrombin Test Time Kit* contains 5  $\times$  2 ml vials of lyophilized thrombin, sufficient for 100 tests. The lyophilized thrombin is reconstituted with 2 ml of distilled water. It is stable for 48 h at 4–8°C but it can be frozen at –20°C and kept for at least 2 years.

##### Control

Obtain locally or use the *Diagen Normal Reference Control Plasma* (see previous text).

*Equipment:* As described for the APTT test.

**Blood specimen:** Collect venous blood into citrate anticoagulant and centrifuge to obtain platelet poor plasma as described for the APTT test. Perform the test with as little delay as possible.

##### TT test method

The method described is that used in the *Diagen Thrombin Test Time Kit*. Test the patient's plasma and control plasma in duplicate.

- 1 Pipette 200  $\mu$ l (0.2 ml) of plasma into a small glass tube. Incubate at 37°C for 1–2 minutes.
- 2 Add 100  $\mu$ l (0.1 ml) of thrombin, mix and start the stop-watch. Hold the tube in the water bath and tilt the mixture back and forth, looking for clot formation. When a clot forms, stop the stop-watch and record the time in seconds.

*Note:* In severe fibrinogen deficiency, the TT is greatly prolonged.

- 3 Report the patient's TT (average of the duplicate tests) providing the TT of the control plasma is satisfactory.

##### Reference TT range

Normal plasma samples clot within 12–15 seconds.

The thrombin time is prolonged in the following conditions:

**Chart 8.7 Information provided by a platelet count, PT, APTT, and TT tests**

Condition	Platelet count	PT <sup>1</sup>	APTT <sup>2</sup>	TT <sup>3</sup>
● Thrombocytopenia	↓	N	N	N
● Chronic liver disease ● Massive transfusion with stored blood	↓	↑	↑	N
● DIC ● Acute liver disease with DIC	↓	↑	↑	↑
● Factor VII deficiency (rare) ● Early oral anticoagulation	N	↑	N	N
● Vitamin K deficiency ● Treatment with oral anticoagulants ● Deficiency of factors V, X, II	N	↑	↑	N
● Haemophilia A, B ● Deficiency of factor XI, XII, prekallikrein, HMWK ● Circulating anticoagulant ● von Willebrand's disease	N	N	↑	N
● Treatment with heparin ● Deficiency of fibrinogen ● Hyperfibrinolysis ● Liver disease	N	↑	↑	↑
● Normal haemostasis ● Disorder of platelet function ● Factor XIII deficiency (rare) ● Disorder of vascular haemostasis	N	N	N	N

Notes: 1 = Prothrombin time, 2 APTT = Activated partial thromboplastin time, 3 TT = Thrombin time  
N = Normal result ↑ = Prolonged time ↓ = Low platelet count

Adapted from JV Dacie and SM Lewis, *Practical Haematology*, 8th edition, Churchill Livingstone.

- DIC and other conditions which produce a low fibrinogen level
- Abnormal fibrinogen
- Treatment with heparin
- Liver failure
- Presence of inhibitors of thrombin such as FDPs (see later text).

*Quality control:* This is as described for APTT tests.

### Fibrinolytic system

Fibrinolysis is the enzymatic process used by the body to remove a fibrin thrombus to restore normal blood flow once damaged endothelium is repaired. During the clotting process, tissue plasminogen activator (t-PA) released from the blood vessel wall and the plasma proenzyme plasminogen bind to the

forming fibrin thrombus. When activated, plasminogen is converted to plasmin which degrades the fibrin network, causing the clot to dissolve. During this process fibrin degradation products (FDPs), i.e. fragments called D-Dimers are produced.

#### *Raised FDP levels in DIC*

In the disorder, disseminated intravascular coagulation (DIC), activated procoagulants are released into the circulation. Platelets and coagulation factors are consumed and fibrin is deposited in small vessels, activating the fibrinolytic system. The plasmin formed degrades the fibrin (also some fibrinogen), resulting in a build-up of FDPs in the circulation. The FDPs act as anticoagulants interfering with platelet function and fibrin stabilization.

Laboratory tests are available to detect and semi-

quantify FDPs (D-Dimers) in plasma. Most are simple to perform slide tests using latex particles coated with anti-D-Dimer or IC cassette tests such as *Clearview Simplify D-dimer test*, available from Unipath (see Appendix 11). FDP titres in excess of 500 ng/ml can be found in DIC (also in thrombosis, phlebitis, and embolism). In DIC, the APTT, PT and TT are prolonged and the platelet count is reduced. In severe DIC, blood is often incoagulable.

### **Bleeding and clotting disorders associated with snake envenomation**

Abnormal bleeding and incoagulable blood are particularly associated with viper envenomation although not all viper venoms contain haemorrhagic and procoagulant components that cause DIC.

**Vipers:** Large family of land snakes with long (10–30 mm) fangs which are easy to see when erect. The neck and head are clearly divided.

In Asia the bite of the saw-scaled or carpet viper (*Echis* species) can cause incoagulable blood and the venom of the Russell's viper in India and Sri Lanka is also associated with DIC. In Africa, the venom of *Echis* species also causes incoagulable blood, the venom of the puff adder can cause endothelial cell damage, thrombocytopenia, DIC and spontaneous haemorrhage, and the venom injected by the bite of some spitting cobras is also associated with DIC following extensive necrosis. In tropical America, the venoms of many rattlesnakes contain procoagulants.

Bleeding and incoagulable blood due to snake envenomation requires immediate treatment with the appropriate antivenom to neutralize circulating venom. A simple whole blood clotting time test can be used to assess antivenom treatment, i.e. dispense about 2 ml of venous blood into a *dry clean* small glass test tube, leave undisturbed, and observe for clotting after 20 minutes by tilting the tube.

*Note:* A neutrophilic leukocytosis is common in all types of severe snake envenoming.

#### FURTHER READING

**Evatt BL, et al.** *Fundamental diagnostic haematology: The bleeding and clotting disorders*, World Health Organization & US Dept of Health and Human Services, CDC, 1992. Available from WHO Publications, WHO, 1211 Geneva, 27-Switzerland.

**Flemming AF, deSilva PS.** Disorders of haemostasis. In *Mansons Tropical Diseases*, 21st ed, 2003, pp. 233–239.

---

# 9

## Blood transfusion practice

### 9.1 Blood transfusion services at district level and quality assurance

At district level in tropical countries, blood is mainly used in the management of emergencies involving:

- Infants and young children (usually below 5 y) with life-threatening anaemia accompanied by respiratory distress, most frequently caused by severe falciparum malaria and, or, malnutrition.
- Women with severe anaemia and, or, acute blood loss related to pregnancy or childbirth.

In many tropical countries there is a high risk of transmitting human immunodeficiency virus (HIV), hepatitis viruses and other transmissible infections in blood and blood products, when blood is not screened for infectious agents. Blood transfusion also carries the risk of immunological adverse reactions. Because of the risks involved, scarcity of blood, and high cost of blood collection, screening, and testing, it is important for clinicians to ensure:

- *Blood is used only when it is absolutely necessary after a careful clinical assessment and measurement of a patient's haemoglobin (or PCV).*

It is inappropriate to use blood to treat patients with:

- stable anaemia without signs of heart failure or respiratory distress which can be treated by other means.
  - acute blood loss when it is possible to use replacement fluids (crystalloids or colloids) to maintain blood pressure and oxygenation.
- *The recipients of blood are not put at unnecessary risk by using blood that:*

- has been collected from a high risk donor.
- has not been collected aseptically using a sterile technique.
- has not been transported or stored correctly.
- has not been screened for important pathogens using sensitive assays.
- has not been typed (grouped) and compatibility tested correctly using standardized controlled procedures.

#### *Avoiding the need for blood transfusion*

In developing countries important measures that can help to avoid the need for blood transfusion, include:

- Reducing the prevalence and severity of anaemia, particularly among pregnant women and young children.
- Avoiding obstetric related haemorrhages by improving antenatal care and attendance at clinics.
- Implementing effective malaria control.
- Using health education to improve nutrition and awareness of the causes of anaemia and its prevention.
- Reducing blood loss during surgery and ensuring alternatives to blood are available

#### **Organization of blood transfusion services at district level**

In recent years, concern for the safety of blood supplies, scarcity of blood, rising cost of supplies, and need for standardization and accountability, have led in some countries to better organized and resourced, more efficient and safer national blood transfusion services (NBTS) with the establishment of NBTS supported regional transfusion centres. In several countries, restructuring of NBTS with an integrated national blood policy have resulted in district hospitals being supplied with blood that has been screened and typed centrally or regionally.

Where blood transfusion services remain hospital-based, it is important for a hospital to establish low infection risk donor panels from the local community and to screen all blood for transfusion transmitted infections. The central NBTS or regional blood transfusion centre usually assists with the supply of blood bags, blood collection and blood giving sets, test kits to screen blood for HIV and other pathogens, blood grouping antisera, and other essential reagents. Most NBTS also provide training in the selection and counselling of blood donors, collection and storage of blood, techniques for screening blood for infectious pathogens, blood typing and compatibility testing, and how to document procedures and keep blood transfusion records.

In many countries, the International Federation of Red Cross and Red Crescent Societies assist NBTS and health authorities in the development of a national blood policy and are actively involved in the recruitment and retention of voluntary non-paid blood donors. Assistance is also provided by the *World Health Organization Blood Safety Unit* and *UNAIDS* programme in promoting the appropriate use of blood, blood products and blood substitutes, voluntary non-remunerated blood donation, processing and storage of blood, screening of blood for HIV and other transfusion transmissible agents, and quality assurance relevant to blood transfusion activities.

**Availability of materials:** Some of the guidelines, documents, publications, and learning materials produced by *WHO Blood Safety and Essential Health Technologies Unit*, and *International Federation of Red Cross and Red Crescent Societies*, can be found at the end of subunit 9.4.

### Guidelines for the use of blood in tropical countries

#### TREATMENT OF ANAEMIA

- **For adults**, including pregnant women, blood transfusion is indicated when:
  - a patient is in danger of dying of anaemic heart failure or hypoxia before specific medication can raise the haemoglobin.
  - Obstetric delivery is imminent and the mother's haemoglobin is below 70 g/l (7 g/dl).
  - Emergency major surgery is essential and the haemoglobin is below 80 g/l (8 g/dl) with an anticipated blood loss of more than 500 ml.

*Note:* In the above situations, the use of concentrated red cells (10 ml/kg body weight), is indicated to avoid cardiac overload. The transfu-

sion should be administered slowly over 4–6 hours. When indicated, a rapidly acting diuretic should be administered. The pulse and respiratory rate should be monitored and the chest examined to detect volume overload.

- **For infants and young children**, blood transfusion is indicated when:
  - the haemoglobin is below 50 g/l (5.0 g/dl) and is associated with respiratory distress, or
  - the haemoglobin is below 40 g/l (4.0 g/dl) and is complicated by malaria or bacterial infection even without respiratory distress, or
  - the haemoglobin is below 30 g/l (3.0 g/dl) without apparent infection or respiratory distress.

*Note:* In the above situations, transfusion with *whole blood* (not packed cells), 10 ml/kg body weight, without diuretics will be tolerated. Children with respiratory distress but not profound anaemia should be treated with intravenous colloids, and be transfused only if the haemoglobin falls later to less than 50 g/l.

**Note:** The above revised guidelines for the transfusion of children have been kindly supplied by Dr Alan Fleming. Relevant papers can be found under *Further Information* at the end of this subunit.

Transfusion of concentrated red cells is also indicated when a patient has an incurable anaemia, e.g. thalassaemia or aplastic anaemia.

#### TREATMENT OF ACUTE HAEMORRHAGE

- Blood transfusion is indicated when there is acute haemorrhage with a loss of more than 30% of a patient's total blood volume, and blood pressure and oxygenation cannot be maintained by crystalloid solutions (saline or Ringers' lactate) or colloids (e.g. 5% dextran or 5% hydroxyethylstarch). Acute blood loss should be managed by replacement of volume. Only when shock persists or worsens should whole blood be transfused.

**Postpartum haemorrhage:** Blood transfusion is indicated when hypotension and reduced cerebral function persist after at least 50 ml/kg of volume replacement fluid has been given intravenously and all measures have been taken to stop blood loss.

#### TREATMENT OF NEONATAL JAUNDICE

- For newborn infants with a serum bilirubin above 300 µmol/l, an exchange blood transfusion is indicated.

### Autologous blood transfusion (autotransfusion)

In an autologous transfusion, a patient's blood is collected and reinfused. This removes the risk of an adverse immunological reaction and of transmitting a blood transmissible disease. In some countries this procedure is used for patients undergoing elective (planned) surgery. In developing countries, autologous blood transfusion is mainly used as a life-saving measure during emergency surgery, e.g. for ruptured ectopic pregnancy. This form of autologous blood transfusion is referred to as intraoperative blood salvage.

In most situations in which intraoperative blood salvage is performed, blood is collected from a sterile uncontaminated body cavity using a sterile dish or bowl and filtered through several layers of sterile gauze into a sterile bottle containing acid-citrate dextrose (ACD) or citrate phosphate dextrose (CPD) anticoagulant. The filtered blood is then returned to the patient through a standard blood transfusion giving set.

### QUALITY ASSURANCE IN BLOOD TRANSFUSION PRACTICE

Errors in the misuse of blood, donation of blood, storage and testing of blood, documentation errors, and failure to carry out checking procedures, can have fatal consequences for patients. Errors can also result in blood shortages, expensive reagents being wasted and a lack of confidence by patients and blood donors in blood transfusion services. It is therefore essential to ensure that quality assurance in blood transfusion practice:

- is sufficiently comprehensive but not unrealistic,
- affordable,
- implemented by all those involved,
- monitored.

### Responsibility for QA in blood transfusion practice

A suitably experienced district medical officer must be appointed to take responsibility for the overall management and quality of district blood transfusion services in liaison with NBTS and regional blood transfusion officers, the district laboratory coordinator, district hospital laboratory staff, and district medical officers. One of the most important ways of monitoring the quality of district blood transfusion services is for the regional blood transfusion centre to organize an external quality assurance (EQA) scheme.

### Objectives of quality assurance (QA) in blood transfusion practice

- To prevent unnecessary blood transfusions.
- To provide blood that is consistently safe and effective, traceable, and available when it is needed.
- To obtain blood from low risk healthy donors and promote non-remunerated voluntary blood donation.
- To ensure appropriate tests and controls are used to screen blood for transfusion transmissible pathogens, and to type (group) and compatibility test blood.
- To minimize errors by implementing concise easy to follow standard operating procedures (SOPs) and monitoring staff compliance.
- To prevent patient misidentification and errors in blood labelling, documentation, and blood records.
- To ensure personnel are well motivated and trained to the standard required with sufficient on-site experience and continuing education to perform blood transfusion related techniques *competently and safely*.

### Standard operating procedures (SOPs)

SOPs must be prepared and locally applied for all transfusion related activities.

**SOPs:** The importance and preparation of standard operating procedures and principles of QA are described in 2.4 in Part 1 of the book.

In blood transfusion practice, SOPs are required for the following:

- *Use of blood, blood products and blood substitutes, to include:*
  - Information which must accompany a request for blood.
  - How to calculate the volume of blood to use, particularly when the patient is a child.
  - Identity checks and documentation required when collecting blood from a patient, from the blood bank and before setting up a blood transfusion at the bedside of a patient.
  - Procedure to follow when a patient is being transfused and what action to take should there be an adverse reaction to the blood.
  - System for auditing how blood is used.

■ *Donation of blood, to include:*

- Criteria for accepting a person as a blood donor and details of medical screen and pre-testing procedures.
- Questionnaire to be used with potential donors covering personal medical history and life style.
- Policy and procedure for counselling donors with regard to HIV screening and testing and maintaining the confidentiality of blood donor information.
- Details of how to collect blood from a donor.
- Labelling donor blood.
- Care of the donor following donation and frequency of donation.
- Special requirements of mobile blood donation and transportation of blood.
- Blood donation records.

*Note:* Blood donation is covered in subunit 9.2.

■ *Storage of blood, to include:*

- Temperature requirement, checking and recording the temperature of the blood bank refrigerator.
- Sectioning of refrigerator and location of pre-screened, screened, and crossmatched blood.
- Procedure for checking the appearance of blood for signs of contamination before it is issued and documentation checks to be performed.
- Blood bank records.
- *Locally* important procedures, pertaining to the use and security of a blood bank refrigerator.

*Note:* The storage of donor blood is described in subunit 9.2.

■ *Screening of donor blood for infectious agents and blood typing (grouping), to include:*

- Infectious agents for which screening is required and details of reagents, controls, equipment, techniques, recording results.
- Procedure for typing blood including details of antisera, test cells, controls, techniques, recording results and labelling of blood unit.

*Note:* Screening and typing of donor blood is covered in subunit 9.3.

■ *Compatibility testing (crossmatching) of blood, to include:*

- Details of the request form and patient's blood sample.
- Procedure for compatibility testing including use of controls, interpretation and recording of test results.
- Procedure for emergency compatibility testing.
- Labelling compatible blood.
- Preparation of concentrated red cells.
- Procedure for investigating a transfusion reaction.

*Note:* Compatibility testing is described in subunit 9.4.

■ *Safety issues, to include:*

- Safe handling of blood and blood products.
- Decontamination of work surfaces and laboratory-ware and preparation of sodium hypochlorite solutions (see subunit 3.4 in Part 1 of the book).
- Disposal of 'sharps'
- Disposal of contaminated and expired blood.

■ *Procurement of supplies, to include:*

- Procedures for ordering essential reagents, HIV and other test kits.
- Recording expenditures and keeping financial accounts.
- Reliable systems for transporting essential supplies.
- Checking expiry date and specifications, and recording supplies upon their receipt.
- Storage requirements of antisera, reagents, and test kits.

FURTHER INFORMATION

**Fleming AF, Menendez C, Alonso PL.** Malaria related anaemia. *Parasitology Today*, 16, pp. 469–476, 2000.

**Fleming AF, de Silva PS.** Haematological diseases in the tropics. Ch 15, *Mansons Tropical Diseases*, 21st edition, 2003, Saunders, Elsevier.

## 9.2 Blood donation and storage of blood

At all levels of health care, health personnel should take the opportunity of educating the public about the need for blood and motivating people to become regular voluntary donors to help others. Posters promoting blood donation should be displayed in the local language.

### Blood donation in district hospitals

When a district hospital is not supplied with blood from a regional blood transfusion centre, it is particularly important to recruit voluntary non-remunerated blood donors from among the community e.g. by forming blood donor associations and clubs in local secondary schools and places of employment. Those willing to become blood donors should be informed about the process of blood donation and the confidential medical checks and tests which will need to be performed to safeguard the health of both donor and recipient.

Potential donors should be blood typed (grouped) and a list of typed blood donors held by district hospital staff. Whenever possible, emergency blood needs should be met by maintaining a blood bank containing a few units of typed screened blood.

Blood collected from patients' relatives (following pre-donor checks) should be typed and screened, and with the consent of donors, form part of blood bank stock. When it is suspected that the donor is not a relative but a paid donor, the person should not be accepted as a blood donor. There is a significantly higher risk of transmitting infection when the donor is paid and also a paid donor may be donating blood more often than is recommended.

### Blood donor requirements

To ensure both the well-being of donors and patients, it is essential for the blood donor recruitment officer (or other suitably trained person) to explain to those wishing to become blood donors the need for:

- Disclosure of medical history and details of life style which can help to exclude a high risk donor i.e. one whose blood is at high risk of transmitting a blood-borne pathogen such as HIV.

- A basic health check to assess a person's fitness to donate blood.
- Appropriate tests to screen blood for transfusion transmissible infections with the donor having the option to know the results of the HIV test performed (with counselling provided).

Discussions with those wishing to donate blood must be courteous and sensitive and take place in private (not in an open hospital waiting area). Potential donors must be assured that any personal information disclosed will remain confidential. This means identifying donated blood by a number with only the person donating blood and the blood recruitment officer knowing the identity of the numbered blood and the HIV test result being disclosed only to the blood donor, not to a partner, employer, or any other unauthorized person.

### Medical history and personal details

The information required to assess whether a person is a high risk donor and should not therefore donate blood, is best obtained by requesting the donor to complete an easy to follow questionnaire *with the help of a blood donor recruitment officer*. Whenever possible the questionnaire should be formulated by the national blood transfusion service.

### Examples of questions which are most frequently included in a questionnaire to help decide whether a person should donate blood

- Why do you wish to donate blood?
- Are you in good health and feeling well today?
- In the last two months have you had an illness similar to a bad cold?
- Do you have swollen glands?
- Have you had shingles?
- In the last 6 months have you had sex with someone you are unsure about?
- In the last year have you been given an injection or skin cutting by a traditional healer?
- Have you ever been given a blood transfusion?
- Do you have night sweats?
- During the last year have you lost a lot of weight?
- Are you at present taking any medicines? If yes, provide details.
- Do you inject drugs?
- Have you in the last year had a sexually transmitted infection?
- Do you wish to be told the result of the HIV test performed on your blood?

#### Details of previous donation

- Have you donated blood before?
- If you have donated previously:
  - when did you donate?
  - where did you donate?



*Self-exclusion*

A person is requested not to donate blood if he or she:

- Has sexual relationships with several people.
- Has in the last year contracted a sexually transmitted disease.
- Injects drugs and shares needles and syringes with others.
- Has a partner with AIDS or a partner in hospital with suspected HIV disease.

*Note:* A person who is pregnant should not donate blood.

*Important:* When a person decides not to become a donor (self-excludes) because he or she suspects possible infection with HIV, the person should be offered further confidential counselling and support with the option for an HIV antibody test.

When the blood of a donor gives a positive HIV reaction, the result of the first screening test must be confirmed using a second specific assay (see subunit 7.18.55) *before* discussing the result with the donor. Counselling should be provided (see subunit 7.18.55).

*Note:* When a single HIV test is positive, the donated blood must be discarded.

**Health check before donating blood**

At the time of donation a person should be in good health and not anaemic, malnourished, or dehydrated. The person should not have donated blood within the previous 3 months. Food should have been eaten on the day of donation. Alcohol should not be consumed prior to donating blood. Drinking water should be made freely available to donors before donation, particularly in hot climates.

The age of the donor should be within the range specified by the national blood transfusion service. In tropical countries this is usually 16–18 years up to 50–65 years. Sometimes older people are not sure of their age but it will usually be obvious whether the person is of an acceptable age and sufficiently fit to give blood. The health check must be carried out by a trained person. It should include:

- *Basic physical examination:* To include a check for swollen glands, skin rashes, signs of intravenous drug use or abnormal bleeding (purpura).
- *Weight of the person:* Persons weighing 45–50 kg or more can safely donate 450 ml of blood.

*Note:* In some Asian countries where height/weight are normally small, 350 ml blood donations are routine.

- *Temperature of the person* (to exclude any febrile disease e.g. malaria): A donor should not give blood when their temperature is raised.
- *Measurement of blood pressure:* A donor should not have an abnormally low blood pressure nor a high blood pressure. The upper acceptable limits are a diastolic pressure of 100 mm Hg and systolic pressure of 180 mm Hg. The minimum acceptable blood pressure is 90/50 mm Hg.
- *Pulse rate of the person:* The pulse rate should be regular and less than 100 beats/minute (counting for at least 30 seconds).
- *Test to check for anaemia:* For example, measurement of haemoglobin or PCV or an estimate of haemoglobin level using the *Haemoglobin Colour Scale* (see subunit 8.4.). In most countries persons are accepted as blood donors with a haemoglobin of 120 g/l (12 g/dl) or more and haematocrit of 380 g/l (38%) or more. In some countries the lower limit for men is set at 130 g/l (13 g/dl). Higher haemoglobin levels will be required at high altitudes.

*Important:* Following the health check, if a person is found to be unfit to donate blood, e.g. due to anaemia or other cause, the person should be referred to a medical officer for further investigation and treatment.

**Screening blood for transfusion transmitted infections**

The following are important infectious agents which can be transmitted in transfused blood:

- Human immunodeficiency virus (HIV) 1 and 2
- Hepatitis B virus (HBV)
- Hepatitis C virus (HCV)
- *Treponema pallidum* (agent of syphilis)
- *Plasmodium* species (agents of malaria).
- *Trypanosoma cruzi* (agent of Chagas' disease)

*Note:* Transfusion transmitted infections caused by these pathogens and others are discussed later in this subunit (see *Testing donor blood*).

**BLOOD COLLECTION**

When a district hospital is responsible for obtaining its blood supplies, staff must be trained in blood donation procedures and facilities provided for bleeding donors in the hospital and off-site in appropriate locations (see Plates 9.1 and 9.2). Mobile

blood donation sessions must be planned carefully to ensure good public relations, appropriate facilities, security and hygienic conditions. Correct standardized procedures must be followed regarding selection, checking, and care of donors, collection of blood, packing and transporting of donated blood.

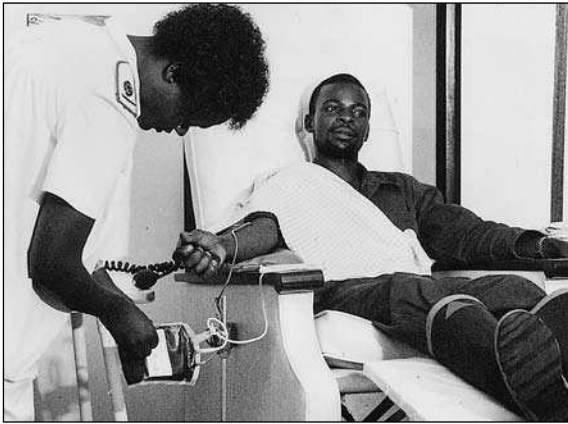

Plate 9.1 Donating blood in a blood transfusion centre. *Courtesy of Denise Hill*

In the hospital, blood donors should be bled in hygienic surroundings in a pleasant, light and airy place close to, but not in the laboratory and not in an open out-patient department without privacy. The donating area should be easily accessible to donors. When donating blood, a donor must *not* be left unattended.

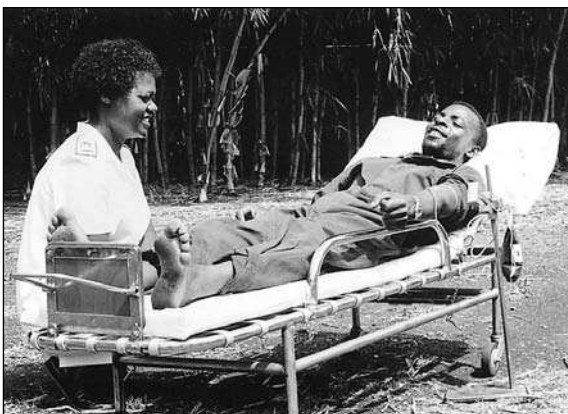

Plate 9.2 Mobile blood donation. *Courtesy of Denise Hill*

### Blood collecting pack

To minimize the risk of microbial contamination of blood and problems associated with collecting blood in bottles (particularly risk of air embolism), most

hospitals and transfusion centres use plastic, single use, closed system blood packs to collect blood from donors. Several types of blood collection pack are available, including:

- Single bag collection pack for collecting 450 ml blood. When concentrated red cells are required, the plasma can be removed and discarded following sedimentation of the red cells (see subunit 9.4) or the transfusion can be stopped when the plasma level is reached.
- Double bag collection pack (450 ml blood) which enables plasma to be saved following its transfer (in a closed system) to the attached sterile bag. A double bag pack costs twice the price of a single bag pack.
- Paediatric quadruple bag collection pack which consists of a blood collecting bag (usually for 250 ml blood) with three small sterile bags attached. Following blood collection, the well mixed blood is subdivided in a closed sterile system between the three attached sterile bags, providing individual small volume packs. When concentrated red cells only are required, the transfusion can be stopped when the plasma level is reached (packs need to be stored inverted). A paediatric bag pack costs about three times the price of a single bag collection pack.

### Other blood collection packs

Multiple bag blood packs are used when preparing blood components in a central blood transfusion centre. Twin and multiple bag collection packs with built-in leukodepletion filter are used routinely in some countries.

### Anticoagulant

The anticoagulant solution used in blood collection bags is CPDA-1 (citrate phosphate dextrose adenine). Most blood collection bags (adult) contain 63 ml CPDA which is sufficient to anticoagulate and ensure the viability of blood cells in 450 ml  $\pm 10\%$  blood for up to 28–35 days when the blood is stored at 2–8°C. Before use, blood collection packs should be stored at below 28°C out of direct sunlight. They have a shelf-life of 2 years or 3 years when supplied in a foil envelope e.g. *Baxter Fenwal* blood packs. The label on the blood pack will show the expiry date.

**Availability of blood collection packs:** There are several manufacturers with distributors in developing countries, including Baxter Healthcare (*Fenwal* blood bags) and Maco Pharma (see Appendix 11). Prices of products vary depending on country and quantity purchased.

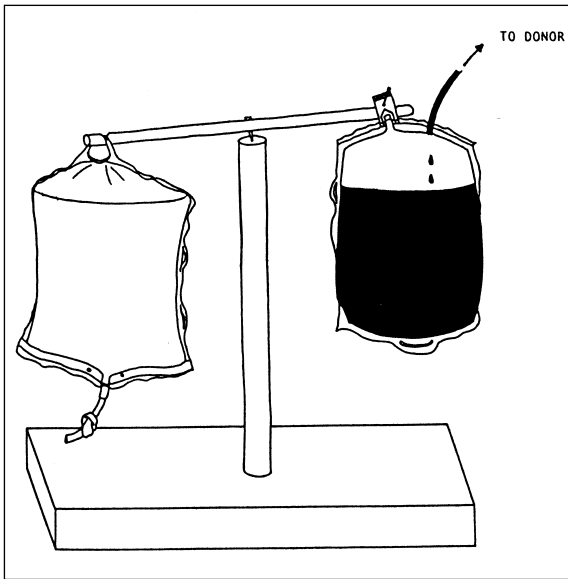

Fig 9.1 Simple scale to show when correct amount of blood has been collected. A blood bag containing water is used as a weight. *Courtesy of Denise Hill*

**Technique of collecting blood from a donor**

- 1 Apply a deflated pressure cuff to the upper arm about 6 cm above the elbow. Raise the pressure to between 60 and 80 mm Hg to enable the veins to be seen and felt. Select a large well situated vein for the venepuncture, usually near the bend of the elbow.
- 2 Clean *very well* the required part of the arm with cotton wool and 70% ethanol (alcohol). Wipe dry with a clean swab of cotton wool.
- 3 Take a blood collecting pack:
  - Make a loose knot (without kinks) in the tubing. When sealing clips are available, there is no need to make a knot in the tubing.
  - Suspend the bag on a stand (linked to a balance) about 30 cm below the level of the donor’s arm.
  - Clamp the tubing near to the needle guard. Whenever possible use plastic forceps to avoid damaging the tubing.
- 4 Make a venepuncture with the needle directed upwards in the line of the vein. Unclamp the tubing to allow the blood to flow. If necessary, secure the needle in place with a small strip of adhesive tape.
- 5 When the blood begins to flow, reduce the pressure of the cuff to 40–60 mm Hg, and ask

the donor to squeeze slowly a small object, as seen in Plate 9.1.

- 6 When the blood enters the pack, gently mix it with the anticoagulant by lifting and tilting the bag. Do not squeeze the bag because this can damage the red cells. Mix the blood a further three times during the donation and when the donation is finished.
- 7 When the pack weighs 500–600g, the donation is complete, i.e. 450–495 ml blood has been collected.

*Note:* The weight of the pack can be measured using a Salter or similar type spring balance. Alternatively, a simple weighted balance as shown in Fig. 9.1 can be used. A water filled blood pack can be used as the weight. This weight will rise when there is sufficient blood in the collecting bag.

- 8 Reduce the pressure in the pressure cuff to zero and remove the object from the donor’s hand. Clamp off the tubing 10–15 cm from the needle (see Fig. 9.2).

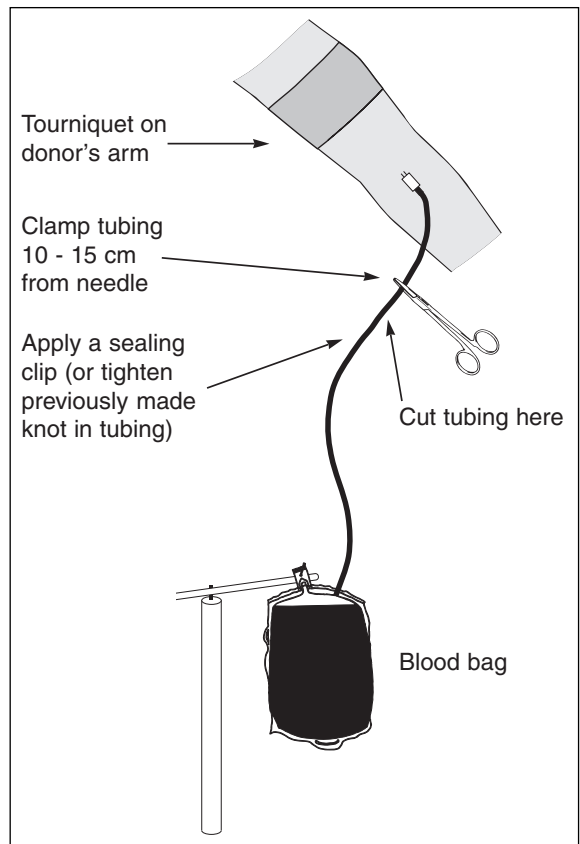

Fig 9.2 Completion of blood donation showing position of clamp and sealing clip prior to cutting the tubing.

- 9 Tie tightly the loose knot in the tubing or fold back the tubing and apply a sealing clip, about 20 cm from the needle (see Fig. 9.2).
- 10 Cut the tubing between the clamp and knot (or sealing clip) as shown in Fig. 9.2.
- 11 Collect a blood sample from the donor into a plain tube for testing (grouping, HIV screening, etc). Unclamp the tubing and allow 5–7 ml blood to run out of the tubing into a tube or vial. Reclamp the tubing.
- 12 Remove the pressure cuff. Take the needle out of the vein, applying pressure with cotton wool. Ask the donor to continue applying pressure to the venepuncture site with his or her other hand. Dispose of the needle safely.
- 13 Mix the blood in the bag and push ('strip') the non-anticoagulated blood from the tubing into the blood bag. Mix and allow the tubing to refill with the anticoagulated blood.
- 14 Write *clearly* the identity number of the donor on the blood pack and sample tube(s). When a blood pack has already been given an *identity* number, e.g. from the blood transfusion service use this number on the sample tube(s). Do not use the manufacturer's lot or batch number because this will be the same on several blood packs.
- 15 After *making sure the bleeding has stopped*, cover the venepuncture site with a pad of cotton wool and adhesive tape (advise the donor to remove the dressing the following day). Thank the person for donating.
- 16 Give the donor a drink (not alcohol) to make up his or her fluid loss.  
Provide the donor with a dated certificate of blood donation and information concerning future donation.
- 17 Check that the blood pack and blood sample(s) have been labelled correctly and the same identity number is written on the blood donation certificate.
- 18 Refrigerate the blood after allowing time for it to cool and for natural bactericidal activity of white cells (1–2 h). Do not leave a blood bag in direct sunlight. To avoid raising the temperature of the blood bank, first store the blood for 3–4 hours in another refrigerator (when the blood bank is an absorption type refrigerator, see later text).

*Note:* Before refrigerating the blood, take a 1–2 ml sample from the pilot tubing of the blood

pack into a sterile tube. Label the tube with the *same identity number as the blood pack*. Store this blood sample in a separate refrigerator and use it for compatibility testing to avoid removing the blood pack from the blood bank refrigerator (when this is an absorption type refrigerator, see later text).

#### *Problems which may occur when collecting blood*

The commonest problem is slowing of the flow of blood. This is often due to the blood clotting in the needle, but before assuming this has happened:

- Check that the pressure in the cuff has not fallen. If it is below 60 mm Hg, increase it to this level and ensure the donor continues to open and close their hand.
- Check that there is no bend in the tubing which is obstructing the flow of blood.
- Adjust *slightly* the needle in the vein without causing distress to the donor and taking care *not to pull the needle out of the vein* because this can cause a haematoma (bleeding into the surrounding tissues).

**Haematoma:** Should a haematoma occur, immediately release the pressure of the cuff, remove the needle and apply firm pressure to the area until the swelling subsides and the bleeding stops. Explain to the donor what has happened and that regrettably bruising of the area is likely to occur. Advise the donor to leave the dressing on the arm for 24 hours.

When all the above fail, it is likely that clotting in the needle has occurred. Stop the donation, release the pressure, clamp the tubing, and when there is sufficient blood in the pack, i.e. not less than 405 ml (minimum weight 500 g), collect the usual blood sample as described previously. When the volume of blood is less than 405 ml, it is not safe to use the donation because the blood will contain too much CPDA. Explain to the donor what has happened.

#### *Adverse donor reactions*

Those responsible for collecting blood from donors must receive essential training in First Aid. When a blood donor feels unwell while giving blood, e.g. faint or nauseated, the donation must be stopped. The donor should be reassured and any tight clothing should be loosened. When possible, increase fresh air in the room. When a donor continues to feel unwell, a medical officer should be called.

When after donating blood, a donor feels faint or dizzy, he or she should lie down, until feeling better.

Alternatively, raising the donor's legs and lowering the head may make the donor feel better. Offer the donor a further drink. When a donor continues to feel faint or dizzy, a medical officer should be asked to attend. The donor should be fully recovered before leaving. Record the details of any adverse reaction on the donor's record card.

*Note:* Further guidelines on how to manage adverse donor reactions can be found in the WHO publication *Safe blood donation, Module 1, Safe blood and blood products* (see Further information, end of subunit 9.4).

## TESTING DONOR BLOOD

Donor blood requires testing as follows:

- Serologically to confirm the ABO and Rhesus group of the donated blood.  
*Note:* Techniques for blood grouping are described in subunit 9.3.
- Screening for transfusion transmissible infections.

### Screening donor blood for infectious agents

Donated blood requires screening for those infectious diseases that are prevalent in the community and carry a significant risk of causing disease in recipients. Important infectious agents include:

- *Human immunodeficiency virus (HIV) 1 and 2:* The risk of developing HIV disease/AIDS after being transfused with HIV infected blood is high (greater than 95%). All donor blood *must be* screened for antibody to HIV-1 and HIV-2 using a sensitive test as described in subunit 7.18.55. As mentioned previously, transmission of HIV in donor blood can be minimized by using low risk voluntary unpaid donors and giving donors the opportunity to self-exclude when they suspect infection with HIV.

*Note:* Even when an HIV antibody screening test is negative, blood may still contain HIV. This can happen when blood is collected during the 'window period', i.e. soon after a donor becomes infected with HIV when antibody to the virus is not yet detectable in the serum.

- *Hepatitis B virus (HBV):* In tropical countries it is thought that up to 6% or more of adults are carriers of HBV. Those at greatest risk of developing viral hepatitis from HBV infected blood and blood products are young children and those without effective immunity. Tests to screen donor blood for HBV are based on the detection

of hepatitis B surface antigen (HBsAg). Several simple to perform rapid tests are available as described in subunit 7.18.54.

- *Hepatitis C virus (HCV):* This can cause viral hepatitis in recipients but it is not as infectious as HBV. Following acute infection, 70–80% of individuals become chronic HCV carriers with the risk of developing liver cirrhosis and liver cancer later in life. Information on the epidemiology of HCV in tropical countries is incomplete. Where the prevalence of HCV is known to be high, donor blood should be screened for antibody to HCV when this can be afforded. Antibody screening for HCV is described in subunit 7.18.54.
- *Treponema pallidum:* Transfusing blood containing *T. pallidum* can cause syphilis in recipients but the risk of transmitting the disease is low, particularly when donated blood is stored at 2–8 °C for 48–72 h which inactivates *T. pallidum*. Tests to screen for *T. pallidum* can be found in subunit 7.18.32.
- *Plasmodium species:* Transfusing blood containing malaria parasites can cause malaria in recipients without effective immunity, e.g. young children and pregnant women. As previously discussed, blood should not be collected from donors with suspected malaria. In malaria endemic areas it is not feasible to screen all donor blood for malaria parasites or reject donors who have had malaria previously. In some malaria endemic areas, it is the policy to give curative antimalarial drugs followed by prophylactic drugs for 3 weeks to all recipients of blood. Tests to detect malaria parasites in blood and rapid antigen tests to diagnose malaria are described in subunit 5.7 in Part 1 of the book.
- *Trypanosoma cruzi:* Transfusing blood containing *T. cruzi* can cause Chagas' disease (see subunit 5.9 in Part 1 of the book). *T. cruzi* is endemic in South and Central American countries from Mexico to Argentina. Donors infected with *T. cruzi* are often asymptomatic and therefore in endemic areas, donor blood must be screened for *T. cruzi*. Guidelines regarding the most appropriate test to use in a particular area should be obtained from the nearest Chagas' Disease Reference Laboratory or regional blood transfusion centre.

**Use of gentian violet:** In some *T. cruzi* endemic areas, gentian violet is added to donor blood (125 mg/500 ml blood) followed by storage at 2–8°C for 24 h to kill *T. cruzi*. Adding gentian violet, however, stains (reversibly) the tissues of the recipient and the dye can also be toxic to some blood components. New more acceptable *T. cruzi* inactivating agents are being researched by the World Health Organization (further details can be obtained from the Trypanosomiasis and Leishmaniasis Unit, Control of Tropical Diseases, WHO, 1211 Geneva, 27-Switzerland).

- **Human T cell lymphotropic virus (HTLV)1:** This virus can cause HTLV disease, adult T-cell leukaemia/lymphoma (ATLL), or tropical spastic paraparesis (TSP). It has a high prevalence in parts of Central and South America, the Caribbean, and parts of sub-Saharan Africa. It is estimated that about 60% of recipients receiving HTLV infected blood actually seroconvert. The risk of developing disease later in life is thought to be low. HTLV antibody screening tests are expensive.

#### Other less common transfusion transmitted pathogens

African trypanosomiasis can be transmitted when donor blood contains *T.b. gambiense* or *T.b. rhodesiense*. It can occur in areas of high prevalence but very few instances have been reported.

Microfilariae can be transmitted in blood and may cause allergic reactions but the larvae are unable to develop further in the recipient and therefore filariasis cannot occur.

Other pathogens which can be transmitted in blood include *Brucella* species, cytomegalovirus, Epstein Barr virus, West Nile virus, prions causing vCJD, and *Babesia* species.

**Vaccinations:** A donor who has been vaccinated recently with a live vaccine should not donate blood for 3–4 weeks or longer depending on the vaccine.

#### Bacterially contaminated blood

Transfusion of bacterially contaminated blood can cause fever, shock, collapse and death. Blood most commonly becomes bacterially contaminated at the time it is collected when the venepuncture site is not cleansed sufficiently or when a non-sterile blood collection set or blood collecting bag is used. Blood must always be examined for signs of contamination at the time of use, i.e. when collected from the blood bank and at the patient's bedside. When grossly contaminated, blood appears haemolyzed and dark in colour. Some bacteria also cause clotting. Bacteria which commonly contaminate blood are able to multiply in refrigerated blood.

#### BLOOD DONOR RECORDS

Accurate confidential records must be kept of:

- blood donors
- blood donations
- results of tests performed on donated blood

#### Blood donation record book

The following is a suggested layout for a district hospital blood donation record book.

##### DONORS

Date	Name	Identification number	Group	Hb	ml blood collected

#### Recording results of tests performed on donor blood

The following is a suggested layout of a district hospital book to record the results of tests performed on donor blood:

##### TESTS ON DONOR BLOOD

Date of Sample	Identification number	Group		HIV		HBsAg		Other test
		Date	Result	Date	Result	Date	Result	

**Blood donor card**

A blood donor card (to be filed in a secure place) should record the following information:

- Donor's name, gender, address (village etc), age, occupation, and written consent to donate blood and for screening tests to be performed.
- Relevant medical history
- Blood group
- Details of donation(s) to include date of donation, results of medical check (haemoglobin, BP, etc), identification number of blood pack, volume of blood collected, and results of tests to screen for infectious agents.

**STORAGE OF BLOOD**

Ideally blood should be stored in an electric thermostatically controlled refrigerator of the compression type with fitted temperature recorder. In most district hospitals this is not possible. Many hospitals do not have mains electricity except for a few hours each day or electricity supplies are intermittent and subject to power surges which can damage electric refrigerators. Solar powered systems are rarely available.

Blood, however, can be safely stored in a gas thermostatically controlled refrigerator of the absorption type providing precautions are taken to ensure the temperature of the refrigerator remains as constant as possible within the range 2–8 °C. This means opening the refrigerator as little as possible. When using an absorption refrigerator, CPDA anticoagulated blood can be stored for up to 28 days at 2–8 °C.

**Using a gas refrigerator as a blood bank**

In most tropical countries, propane gas is usually available locally and is frequently used in district hospitals without mains electricity for heating water and operating autoclaves and stills.

**Kerosene refrigerator:** This is not suitable for use as a blood bank because it is not fitted with a thermostat to regulate the temperature.

When using an absorption gas refrigerator as a blood bank it is important to ensure the refrigerator:

- Is fitted with a gas thermostat and whenever possible is tropicalized, i.e. very well insulated.
- Is sited in a cool, airy, secure place away from direct sunlight. It must be level (checked by using a spirit level) and correctly installed.
- Maintains the correct temperature for storing blood, ideally 4–6 °C and not outside the range

2–8 °C. A thermometer (preferably maximum/minimum type) must be kept inside the refrigerator in a bottle of water and each morning the temperature should be checked and recorded on a chart (see later text).

- Is correctly and safely connected to a gas supply. The gas must not be allowed to run out. Whenever possible two cylinders with an automatic change-over valve should be used. When this is not possible, the amount of gas in the cylinder must be monitored. In practice, the amount of gas used by the refrigerator over a period of time becomes known so that a judgement can be made when to change a cylinder in advance of the gas running out. Any gas remaining in the former cylinder can be used elsewhere in the hospital.
- Is maintained as recommended by the manufacturer.



Plate 9.3 Thermostatically controlled gas operated refrigerator for storing blood in a district hospital.

**Availability of gas refrigerators:** In most tropical countries there are suppliers of gas refrigerators. Models are often available that operate from both gas and electricity. Such dual models are useful in locations where electricity supplies exist but are unreliable. One of the main manufacturers of gas/electric absorption refrigerators with agents in tropical countries is Sibir International AB (see Appendix 11).

Tropicalized models (highly insulated) are available, e.g. S150 GE LP gas/electric refrigerator which is suitable for operating when the ambient temperature is as high as 43°C. The S150 GE model is shown in Plate 9.4. It has a 137 litre capacity and measures 1176 mm high × 592 mm wide × 673 mm depth and weighs 55 kg. It is fitted with both gas and electric thermostats. It has a useful upper -20°C freezing compartment. Gas consumption is stated to be 385 g/24 h.

*Note:* Sibir International also manufactures low energy consumption refrigerator/freezer models (110 litre and 185 litre) for storing vaccines in areas without mains electricity. The refrigerators meet WHO specifications E3.RF/2 and E3.RF/6.



Plate 9.4 Sibir International S150GETLP gas and electric tropicalized refrigerator. *Courtesy of Sibir International AB*

#### *How to avoid raising the temperature of the blood bank*

The following are the main ways of avoiding raising the temperature of an absorption blood bank refrigerator:

- Write on the door of the blood bank 'OPEN ONLY WHEN NECESSARY'. Allow only authorized staff to use the refrigerator.
- Store *only* blood and infrequently used reagents in the refrigerator. *Never* store food or bottles of drink in the blood bank or routinely used reagents.
- Cool freshly collected donor blood in another refrigerator before transferring it to the blood bank.

- Fill empty spaces in the refrigerator with capped containers of cold water.
- Keep *clearly labelled* blood samples of the blood packs in another refrigerator. Use these samples when compatibility testing to avoid removing blood packs from the blood bank.
- When there is a choice, avoid opening the refrigerator during the hottest time of the day.

#### **Layout of a blood bank refrigerator**

Whenever possible separate places should be kept in the blood bank for:

- recently donated blood which has not yet been tested or screened for infectious agents.
- tested screened blood with places for different blood groups.
- ready to issue blood which has been compatibility tested and labelled.

Blood packs should be stored upright to allow for the separation of plasma and red cells. Unwanted plasma can be removed from the pack as shown in Plate 9.5 or alternatively a manual plasma extractor can be used. When the practice is not to discard the plasma before issuing the blood but to allow the transfusion to proceed until the plasma level is reached, blood packs need to be stored inverted. With this practice, however, the plasma is often also transfused. Do not store blood in the compartments of the door of the refrigerator.

*Important:* Blood must *never* be stored next to the freezer unit of a refrigerator because this can haemolyze the red cells. Transfusing haemolyzed blood can be fatal. When a freezer unit is located in the main cabinet of the refrigerator the freezer unit should be insulated with plastic bubble sheeting or other appropriate material which will prevent blood packs touching the freezer.

#### **Transporting blood**

To transport blood, always use a well insulated cool box with sufficient freezer packs. It is essential to prevent the blood bags touching directly the freezer packs. This can be done by placing the blood in a rack with the freezer packs surrounding it but not inside the rack. Alternatively, the freezer packs can be wrapped in paper to avoid their direct contact with the blood bags.

When an insulating box is only half full, fill it with bottles of water containing ice cubes. To maintain the correct temperature of the blood, use as many



freezer packs as blood bags. The freezer packs should still be frozen when the blood arrives at its destination. Pack a thermometer in with the blood and ensure it is read immediately after opening the cool box.

Always use a secure and reliable method of transporting blood. When needing to send blood a considerable distance or during the hot season, a special insulated cool box will be required such as

a vaccine carrier (ensuring the blood is not in direct contact with the freezer packs or freezer wall of the carrier).

When cleaning or defrosting a blood bank refrigerator, a cool box with sufficient freezer packs will be required to maintain stocks of blood below 8°C. Return the blood to the blood bank only when the temperature of the refrigerator has returned to below 8°C.

**Blood bank records**

In a district hospital, blood bank records should include:

- Blood bank temperature sheet on which is recorded daily the temperature of the blood bank. The following is a suggested layout:

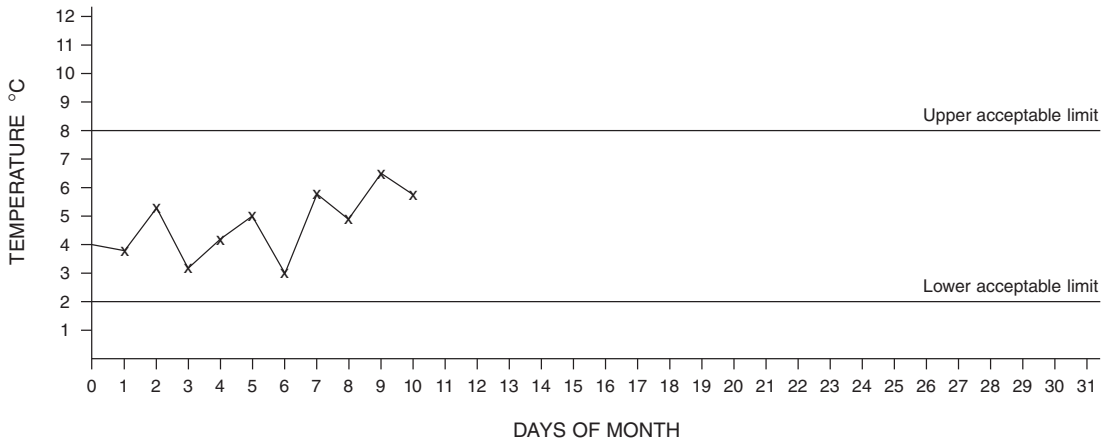

- Blood bank stock sheet, to be kept on top of the blood bank or close to it, which gives information on the blood stored in the blood bank. The following is a suggested layout:

**BLOOD BANK STOCK SHEET**

Identification number	Date stored	Expiry Date	Group	Date tested <sup>1</sup>	Compatibility test date <sup>2</sup>	Issued Date	Signature

*Notes*

- 1 Enter the date when the blood has been tested and found fit for use. When screening tests show the blood to be unfit for use, draw a line through the column, remove, and discard the blood.
- 2 Enter the date when the blood is crossmatched for a patient. When not used, enter the letters NN (not needed) beside the date, indicating the blood is available for another patient.

## 9.3 Blood grouping

The ABO and Rhesus blood group systems are clinically the most important. Blood donors and patients must be correctly ABO grouped because transfusing ABO incompatible blood may result in the death of a patient. Rhesus grouping is also performed routinely except where the population is known to be with few exceptions, Rhesus (Rh D antigen) positive. The risks associated with transfusing Rhesus positive blood to a Rhesus negative person are described later in the text.

*Note:* The importance of some other blood group systems are described at the end of this subunit.

### ABO blood group system

A person's ABO blood group depends on the *A*, *B*, or *O* gene (located on chromosome 9) inherited from each parent as follows:

<i>Genes inherited</i> (genotype)	<i>Blood group</i> (phenotype)
<i>A</i> and <i>A</i> <i>A</i> and <i>O</i> *	Group A
<i>B</i> and <i>B</i> <i>B</i> and <i>O</i> *	Group B
<i>A</i> and <i>B</i>	Group AB
<i>O</i> and <i>O</i>	Group O

\**A* and *B* genes are dominant. The recessive *O* gene is expressed only when *A* and *B* dominant genes are absent. A person who is group O must be of the genotype *OO*.

### *A* and *B* red cell antigens

- A person who inherits *A* gene (*AA* and *AO*) belongs to Group A and expresses A antigen on their red cells.
- A person who inherits *B* gene (*BB* or *BO*) belongs to Group B and expresses B antigen on their red cells.
- A person who inherits *A* and *B* genes belongs to Group AB and expresses both A and B antigens on their red cells.
- A person who inherits *O* genes belongs to Group O and does not express A or B antigens on their red cells.

Antigens A and B are formed from H substance.

### Formation of red cell antigens A and B from H substance

The dominant *H* gene (located on chromosome 19) encodes

for an enzyme which converts a carbohydrate precursor substance in red cells into H substance (H antigen). *A* and *B* genes encode for specific transferase enzymes which convert H substance into A and B red cell antigens. *O* gene encodes for an inactive transferase enzyme which results in no conversion of the H substance in group O red cells.

Persons who do not inherit H gene (very rare *hh* genotype) are unable to produce H substance and therefore even when *A* and *B* genes are inherited, A and B antigen cannot be formed. This rare group is referred to as Oh, or Bombay group (originally recognized in Marathi-speaking people of India). Antibodies anti-A and anti-B are present in the blood of Oh Bombay persons.

*Secretors:* Up to 80% or more of people inherit the secretor gene *Se* and secrete water soluble H, A, and B antigens in their saliva, plasma, and other body fluids in addition to expressing the antigens on their red cells. Knowing whether a person is a secretor is not important in routine blood transfusion practice.

In leukaemia and some other diseases, red cell antigens can disappear or become weaker while in other malignant diseases e.g. gastrointestinal cancer, a B like antigen substance is occasionally produced in group A persons.

### **Anti-A and anti-B antibodies**

- A person who is group A has anti-B antibody in their serum.
- A person who is group B has anti-A antibody in their serum.
- A person who is group AB has neither anti-A nor anti-B antibody in their serum.
- A person who is group O has both anti-A and anti-B antibody in their serum.

In the ABO blood group system, naturally occurring IgM anti-A and anti-B are present in the serum in the absence of the corresponding red cell antigen. Although described as naturally occurring (allo-) antibodies, anti-A and anti-B are not detectable in the blood of newborn infants. The antibodies become detectable at about 3 months of age following exposure to A and B like substances present in the environment e.g. in bacteria and some foods. As a person gets older the concentration of naturally occurring anti-A and anti-B in the blood becomes less and these antibodies may be difficult to detect in the serum of some elderly patients.

Occasionally IgG hyperimmune anti-A and anti-B can be found in the serum of group O persons in response to stimulation by A and B like antigens in the environment, and following pregnancy, or the injection of some vaccines or toxoids. In tropical countries it is common to find lytic IgG anti-A, anti-B, or both in the fresh serum of up to 50% group O persons. Lytic anti-A is also found in group B

persons and lytic anti-B in group A persons (about 25% of sera).

Serious haemolytic reactions can occur when Group O whole blood containing anti-A and anti-B haemolysins is used to transfuse non-group O persons. Immune IgG lytic anti-A and anti-B can cross the placenta and cause ABO haemolytic disease of the newborn (HDN) as described in subunit 9.4.

Blood group	Antigen on red cells	Antibody in serum
A	A	Anti-B
B	B	Anti-A
AB	A and B	–
O	–	Anti-A and Anti-B

FREQUENCY OF OCCURRENCE OF ABO GROUPS					
Examples	Group	A%*	B%*	AB%*	O%*
Asian		28	27	5	40
African		26	21	4	49
Nepalese		33	27	12	28
Caucasian		40	11	4	45

\*Approximate average percentages. Marked differences can occur between ethnic groups. Accurate figures can usually be obtained from the national blood transfusion service or the Red Cross and Red Cross Crescent Societies operating in different countries.

**ABO subgroups**

Antigen A exists as strongly reacting antigen A<sub>1</sub> and a weakly reacting antigen A<sub>2</sub>. Most people who are group A or Group AB possess A<sub>1</sub> antigen, i.e. they are group A<sub>1</sub> or group A<sub>1</sub>B. Fewer people (up to 20%) belong to the subgroups A<sub>2</sub> or A<sub>2</sub>B. Antibodies present in the serum of those with antigen A<sub>1</sub> and antigen A<sub>2</sub> are as follows:

Group	Antibody in serum
A <sub>1</sub>	anti-B
A <sub>2</sub>	anti-B, anti-A <sub>1</sub> * in up to 2%
A <sub>1</sub> B	none
A <sub>2</sub> B	anti-A <sub>1</sub> * in up to 25%

\*Anti-A<sub>1</sub> is usually a weakly reacting antibody and is therefore not important when selecting blood for transfusion.

**Other A subgroups**

Several other variants of weakly reacting antigen A have been recognized including, A<sub>3</sub>, A<sub>end</sub>, A<sub>bantu</sub>, A<sub>X</sub>, etc. A<sub>bantu</sub> has its highest frequency in the Khosian people of southern Africa.

Antigen A<sub>2</sub> and some of the rarer more weakly reacting variants of antigen A can be detected using a monoclonal anti-A serum (see later text) or when this is not available, using also an anti-AB serum. Up to 2 minutes should be allowed for the reaction to occur.

*Note:* Weakly reacting variants of antigen B also exist but are rare. Some can be detected using a monoclonal anti-B serum.

**Rhesus blood group system**

The Rhesus (Rh) blood group system is next in importance to the ABO system in blood transfusion practice but it is not of equal significance in every country because the frequency of the most important of the Rhesus antigens, i.e. D antigen, varies in different populations as follows:

Examples	Rhesus (D) positive*
Asian	90–98%
African	94–95%
Nepalese	99–100%
Oriental	99–100%
South American people:	
Ecuador, Chile	91–97%
Brazil, Argentina, Uruguay	82–94%
Caucasian	About 85%

\*Marked differences in figures can occur between ethnic groups.

**Rhesus antigens**

The Rhesus blood group system consists of six genes: Cc, Dd, Ee. A single chromosome can carry C but not c, D but not d, and E but not e. A person inherits from each parent a set of three closely positioned Rhesus genes, e.g. CDE/cde. At least 36 Rhesus genotypes are possible based on the combinations of genes that can be inherited (see following table).

Gene combinations (single chromosome)	Short notations for gene combinations
CDe	R <sup>1</sup>
cDE	R <sup>2</sup>
cDe	R <sup>0</sup>
CDE	R <sup>z</sup>
Cde	r <sup>+</sup>
cdE	r <sup>-</sup>
CdE	r <sup>y</sup>
cde	r

When using the Fisher-Race derived nomenclature, Rhesus antigens bear the same name as their genes, i.e. antigens D, C, c, E and e (d gene is not expressed). Rhesus antigens are only expressed on red cells. They are not found in body fluids.

Medically, antigen D is the most important of the Rhesus antigens because it is the most immunogenic, capable of producing immune (IgG) anti-D antibody which can cause haemolytic reactions (see later text, *Rhesus antibodies*). A person is grouped as Rhesus (Rh) positive or negative based on the presence or absence of antigen D:

- *Rh positive*: A person inherits gene *D* and their red cells express antigen D.
- *Rh negative*: A person does not inherit gene *D* and their red cells do not express antigen D.

#### *Weak antigen D*

Several weak antigen D forms are recognized, including what was formerly called antigen D<sup>U</sup>. The term weak antigen D is used to describe those forms of antigen D where the number of red cell D receptors is reduced. Such weak D cells react less strongly than red cells with normal numbers of D receptors. Monoclonal IgM anti-D serum will detect weak antigen D (see *Blood grouping techniques*). In some African and other populations, weak antigen D has been found in up to 10% of people.

#### **Partial antigen D variants**

These are *very* rare forms of antigen D in which parts (epitopes) of antigen D are missing. A person with partial D e.g. D<sup>VI</sup> cells is able to produce anti-D antibody against the missing epitopes of the antigen. To prevent the risk of such a person receiving Rh positive blood, it is important that the person is grouped as Rh negative, i.e. Rhesus grouped using an IgM anti-D antiserum which will not detect D<sup>VI</sup> antigen.

Donors with antigen D<sup>VI</sup> should be grouped as Rhesus positive. To do this a donor needs to be tested by the antiglobulin technique using a blended anti-D antiserum (containing IgG and IgM) which will detect D<sup>VI</sup> cells. The decision to test donors for antigen D<sup>VI</sup> will depend on the number of Rh negative people in the population and whether it is cost effective when the frequency of antigen D<sup>VI</sup> is so low.

#### **Rhesus antibodies**

In the Rhesus blood group system, naturally occurring Rhesus antibodies are not found in the serum of persons lacking the corresponding Rhesus antigens. Rhesus antibodies are formed by immunization.

The most important of the Rhesus antibodies is anti-D. This can be formed when a Rh negative person is transfused Rh positive blood or when a Rh negative woman becomes pregnant with a Rh positive infant and the red cells of the baby pass into her circulation particularly at the time of delivery, stimulating the production of anti-D antibody. Such circulating anti-D will not become immediately harmful unless the person receives a transfusion of Rh positive blood. In such a situation the donor's D

antigen red cells will be haemolyzed by the anti-D.

Circulating immune anti-D antibodies can also cause haemolytic disease of the newborn (HDN) when a mother with anti-D becomes pregnant with a Rhesus positive infant. IgG anti-D can pass across the placenta into the circulation of the fetus and destroy fetal red cells. In Rh HDN, an infant may be stillborn or born jaundiced with severe haemolytic anaemia. The laboratory investigation of HDN is described in subunit 9.4.

#### **Preventing Rh HDN**

Rh HDN can be prevented by administering prophylactic IgG anti-D within 72 h of a Rh negative mother (without anti-D antibodies) giving birth to a Rh positive infant. The anti-D suppresses the formation of maternal anti-D antibodies, protecting a future Rh positive pregnancy.

*Note:* Less commonly, other immune Rhesus antibodies such as anti-E or anti-C are associated with haemolytic reactions. Anti-C is occasionally found with anti-D.

#### **Blood grouping techniques**

The safe transfusion of patients depends on the correct ABO grouping of donors and recipients. The decision to Rhesus group will depend on the frequency of the Rhesus D antigen in the population, national policy, and availability of reagents. Standardized adequately controlled procedures must be followed for both emergency and routine blood grouping. Reagents, particularly blood grouping antisera, should be obtained from a reliable supplier and the instructions provided by the manufacturer regarding storage and use must be followed carefully.

ABO and Rhesus grouping can be performed in tubes, on tiles, slides or in microplates (microtitration plates) using liquid antisera. In blood transfusion centres, blood donors can be grouped economically using a spun microplate technique. A centrifuge with a microplate rotor is required. In district laboratories, spun tube and tile techniques are mainly used for grouping donors and recipients.

**Antisera-impregnated gel systems:** Blood grouping gel-antiserum card systems are commercially available for ABO and Rh grouping. They are however very expensive compared with using liquid blood grouping antisera. A special centrifuge is also required to hold the cards and provide the correct centrifugal force to sediment the red cells through the antisera-impregnated gel. The shelf-life of the cards is about 1 year.

#### *Conditions required for antigen-antibody reactions*

The correct conditions must exist for an antibody to react with its corresponding red cell antigen to produce sensitization (antibody binding) and agglutination of the red cells or haemolysis. Antigen-antibody reactions are affected by the type

of antibody, ionic strength of the medium, temperature, pH, and ratio of antibody to antigen.

**Type of antibody:** Blood group antibodies are mainly IgM, e.g. anti-A and anti-B, and IgG, e.g. immune anti-Rh antibodies. IgM antibodies are large molecules easily able to bind to antigens (10 binding sites) and link red cells together, causing their agglutination in a saline medium. They are also able to activate and bind complement. IgG antibodies are much smaller with only two antigen binding sites, resulting in red cells being sensitized but not agglutinated in saline. Albumin, antiglobulin reagent, or proteolytic enzymes are used to agglutinate IgG sensitized red cells in laboratory tests.

**Ionic strength of medium:** The rate at which antigen-antibody reactions occur is increased when the ionic strength of a medium is reduced, e.g. when red cells are suspended in low ionic strength saline (LISS).

**Temperature:** Most immune IgG antibodies react best at warm temperatures while IgM antibodies react best at room temperature and colder temperatures.

**pH:** A pH of between 6.5–7.5 is best suited for blood group antigen-antibody reactions.

**Ratio of antibody to antigen:** There must be an optimum rate of antibody to antigen sites for agglutination of red cells to occur. The red cell suspension used in agglutination tests must not be too strong. The manufacturer of a blood grouping anti-serum will advise on the strength of a red cell suspension to use in tube, tile, and microplate techniques.

## ABO GROUPING

ABO grouping consists of:

- *Cell grouping* in which the red cells are tested for antigens A and B using anti-A and anti-B sera.
- *Serum grouping (reverse grouping)* in which the serum is tested for anti-A and anti-B antibodies using known A and B red cells.

Performing both cell and serum grouping greatly reduces the risk of errors in ABO grouping (serves as a double check). There is less risk of misgrouping a group A person with weak antigen A as group O (or group AB as group B) because the error will be detected when serum grouping. Errors due to autoagglutination will also be detected more easily. Serum grouping using a tube will also detect the presence of anti-A and anti-B haemolysins in group O donor blood (see later text).

### *Grouping infants and elderly patients*

Serum grouping is not performed when grouping infants below 4 months of age because naturally occurring anti-A and anti-B antibodies are only formed 3–4 months after birth. When ABO grouping elderly people or persons with a gamma globulin deficiency, anti-A and anti-B may react weakly in the serum group and therefore cell grouping will be more reliable.

## ABO cell and serum grouping using a spun tube technique

To perform ABO cell and serum grouping, the following are required:

- Blood sample
- Anti-A and anti-B sera
- 3–5% A and B cell suspensions (freshly prepared)
- Controls

### *Blood sample*

When grouping a donor, use the blood sample collected at the time of blood donation. Test it within 24–36 hours. When grouping a patient, collect 5–7 ml of venous blood into a dry *glass* tube and label clearly. When completely clotted, centrifuge the blood at about 1 000 g for 3–5 minutes to separate the cells from the serum. Also collect an EDTA blood sample (see subunit 8.3). Make a 3–5% washed red cell suspension as follows:

- Transfer about 0.5 ml of EDTA blood (or red cells from a donor blood sample) into about 5 ml physiological saline (Reagent No. 68).
- Centrifuge at about 1 000 g for 2–3 minutes. Discard the supernatant fluid, resuspend the sedimented red cells in a further 5–7 ml saline and centrifuge. Discard the supernatant fluid.
- Make a 3–5% red cell suspension by mixing 1 drop of sedimented cells in 20–25 drops of saline (hold the Pasteur pipette vertically).

### *Anti-A and anti-B antisera*

Whenever possible, use monoclonal blood grouping antisera. Most commercially available antisera are monoclonal. Anti-A antiserum is colour coded blue and anti-B antiserum is colour coded yellow.

Commercially produced antisera contain a preservative (e.g. 0.1% sodium azide) and most have a shelf-life of two years from the date of manufacture. Antisera require storage at 2–8°C. Not *all* antisera can be frozen (this information can usually be found in the manufacturer's literature).

*Note:* When using a monoclonal anti-A antiserum it is not necessary to include an anti-AB antiserum in cell grouping.

### **Monoclonal antisera**

Most monoclonal anti-A and anti-B sera are produced by tissue culture using hybridoma cell lines derived from fusing (hybridising) mouse myeloma cells with specific antibody secreting lymphocytes (from immunized mice). The fused cells are cloned and cultured. Monoclonal reagents are therefore specific, stable and reproducible, giving consistent results. They agglutinate strongly and rapidly (avidly) and are able to

detect weak reacting antigen variants, e.g. A<sub>2</sub> and other weak antigen A variants. A further important advantage is that monoclonal anti-A and anti-B antisera being of animal origin, are free from infectious agents such as HBV and HIV. Polyagglutination due to the Thomsen phenomenon does not occur because anti-T antibody is not present in monoclonal antisera.

**Availability:** Most of the main manufacturers of antisera have suppliers in tropical countries. Prices vary depending on manufacturer, country, and quantity of antisera purchased. Most anti-A and anti-B sera are sold in 10 ml bottles with a dropper cap. When only a few groupings are performed, dividing an antiserum into smaller volumes (using sterile screw-cap containers) will help to ensure the reagent is used up to its expiry date and not discarded before that date due to contamination.

### A and B cells

Although red cell reagents for serum grouping are available from the manufacturers of antisera they are expensive and have a short shelf-life. Most district laboratories prepare their own A and B test red cells from persons known to be group A and group B. The cells must be labelled clearly and dated.

When collected into sterile anticoagulant preferably CPDA or when not available ACD, the test cells can be kept for 2–3 weeks providing the blood is refrigerated at 2–8 °C and a sterile needle is used each time the cells are removed. Fresh A and B blood samples must be prepared at the end of 3 weeks or before should the samples haemolyse.

### Collection of blood into CPDA

Sterile citrate phosphate dextrose adenine (CPDA) can be obtained from a blood collecting bag. It is not easily made locally. Mix 10 ml of blood with 1.6 ml CPDA.

### Collection of blood into ACD

Sterile acid citrate dextrose (ACD) can be prepared easily in a district laboratory (see Reagent No. 5). Mix 10 ml of blood with 2.8 ml ACD.

Before use, wash the CPDA or ACD anticoagulated A and B test cells in saline and prepare 3–5% cell suspensions (20–30% when tile grouping) as described previously.

**Group O cells:** Some laboratories also include group O cells when serum grouping to detect irregular antibodies which may be present in the serum of a patient or donor following immunization during pregnancy or as a result of a previous blood transfusion.

### Controls

The reactions of anti-A and anti-B sera can be checked using A cells, (preferably A<sub>2</sub> cells) and B cells. A and B cell suspensions can be checked using anti-A and anti-B sera.

**Important:** Inclusion of an autocontrol, i.e. patient's red cells added to their own serum, is essential to detect the presence of autoagglutination. This can occur when an autoantibody is present or a person has ingested a herbal preparation causing autoagglutination of their red cells.\*

\*It is particularly important to use an autocontrol to check for autoagglutination when only cell grouping and a patient is typed as group AB.

### Tube method

1 Take five small (e.g. 63 × 9.5 mm) tubes\* and label them 1 to 5.

\*When reusing tubes for blood transfusion work, use glass tubes because it is difficult to completely clean plastic tubes of traces of protein or detergent.

2 Pipette into each tube as follows:

Tube 1 1 volume anti-A serum  
1 volume 3–5% patient's red cells

Tube 2 1 volume anti-B serum  
1 volume 3–5% patient's red cells

Tube 3 1 volume patient's serum  
1 volume 3–5% A cells

Tube 4 1 volume patient's serum  
1 volume 3–5% B cells

Tube 5 1 volume patient's serum  
(Auto-control) 1 volume patient's 3–5% red cells

3 Mix the contents of the tubes by gently tapping the base of each tube with the finger.

4 Leave the tubes at room temperature for 5 minutes. Centrifuge at lowest setting (e.g. 150 g) for 1 minute or at 500–1 000 g for 10–15 seconds.

5 Replace the tubes in the rack in the same position as before centrifuging. Read the results by tapping gently the base of each tube, looking for agglutination or haemolysis. Record the results in the *Blood Grouping Book* and on the patient's form. Interpret the results as follows:

Tube 1 <i>Anti-A</i>	Tube 2 <i>Anti-B</i>	Tube 3 <i>A cells</i>	Tube 4 <i>B cells</i>	Tube 5 <i>Control</i>	Group
+	–	–	+	–	<b>A</b>
–	+	+	–	–	<b>B</b>
+	+	–	–	–	<b>AB</b>
–	–	+	+	–	<b>O</b>

*Note:* Haemolysis is recorded as a *positive* (+) reaction. When a reaction is weak, record this (WK). Group O donor blood found to contain anti-A and anti-B haemolysins should be labelled. *Use as whole blood for group O patients only or use as concentrated red cells.*

**Emergency ABO cell and serum grouping using a tile technique**

Occasionally it may be necessary to perform a rapid emergency ABO group. The following are required:

- Patient's blood sample (clotted and EDTA samples) as described previously except a 20–30% red cell suspension of the patient's cells is used (add 5 drops packed washed red cells to 20 drops saline).

*Note:* Incubating the patient's blood sample at 37°C will speed up clotting and clot retraction.

- Anti-A and anti-B sera, see previous text.
- 20–30% A and B cell suspensions (freshly prepared).
- Autocontrol

**Tile method**

- 1 Divide and mark a white tile as follows:

1 <i>Anti-A</i>	2 <i>Anti-B</i>	3 <i>A cells</i>	4 <i>B cells</i>	5 <i>Control</i>
--------------------	--------------------	---------------------	---------------------	---------------------

- 2 Pipette into each division as follows:
  - 1 1 volume anti-A serum  
1 volume 20–30% patient's red cells
  - 2 1 volume anti-B serum  
1 volume 20–30% patient's red cells
  - 3 1 volume patient's serum  
1 volume 20–30% A cells
  - 4 1 volume patient's serum  
1 volume 20–30% B cells
  - 5 1 volume patient's serum  
1 volume patient's 20–30% red cells
- 3 Mix the contents of each division using a small clean piece of applicator stick for each.
- 4 Tilting gently the tile from side to side, look for agglutination. After 2 minutes, record the results in the *Blood Grouping Book* and on the patient's card.

*Important:* Although agglutination reactions are often seen well within 2 minutes, the full time must be allowed to detect weak reactions, e.g. A subgroups. Do not delay reading the results beyond 2 minutes because false reactions may result from drying of the mixtures.

- 5 Interpret the results as follows:

1 <i>Anti-A</i>	2 <i>Anti-B</i>	3 <i>A cells</i>	4 <i>B cells</i>	5 <i>Control</i>	<b>Group</b>
+	–	–	+	–	<b>A</b>
–	+	+	–	–	<b>B</b>
+	+	–	–	–	<b>AB</b>
–	–	+	+	–	<b>O</b>

**Preliminary rapid cell ABO grouping of blood donors**

It is usual to perform a rapid cell group before a person donates when the blood is for storage in a district hospital blood bank. The preliminary blood group *must* be confirmed by the tube cell and serum grouping technique described previously.

**Method**

- 1 Mark a glass slide as follows:

<i>Anti-A</i>	<i>Anti-B</i>
---------------	---------------

- 2 Pipette into each division as follows:
  - Anti-A* 1 volume anti-A serum\*  
1 volume donor's capillary blood
  - Anti-B* 1 volume anti-B serum\*  
1 volume donor's capillary blood
- 3 Mix the contents of each division using a clean piece of stick for each.
- 4 Tilting the slide from side to side, look for agglutination and record the results after 2 minutes in the *Blood Donor Book*.

*Important:* Allow a full 2 minutes before recording the result to avoid missing weak reactions, e.g. A subgroups.

5 Interpret the results as follows:

<i>Anti-A</i>	<i>Anti-B</i>	<b>Group*</b>
+	–	<b>A</b>
–	+	<b>B</b>
+	+	<b>AB</b>
–	–	<b>O</b>

\*Confirm by tube cell and serum grouping (see previous text).

### Difficulties in ABO grouping

Discrepancies in ABO grouping can be caused by faulty technique, deterioration of reagents (antisera or test cells), or by rouleaux or autoagglutinins. See also previous text *Grouping infants and elderly patients*.

#### *Deterioration of reagents*

Occasionally difficulties in ABO grouping are caused by using expired or contaminated reagents or incorrectly prepared or heavily contaminated physiological saline. Appropriate controls should be used to check the reactions of antisera and test cells (see previous text, *Controls*). Prepare fresh saline if contamination is suspected (check a sample microscopically).

#### *Rouleaux*

Rouleaux causes red cells to stack together (like piles of coins), giving the appearance of agglutination when there is no true agglutination. It can occur when a patient has a protein abnormality, e.g. myelomatosis (see subunit 8.2) or when dextran, PVP, or similar product has been given intravenously. In cord blood samples, rouleaux can be caused by contamination of the sample with gel substances such as Wharton's jelly when applied to the cord of a newborn (wash the infant's red cells with 37°C saline).

Marked rouleaux can cause discrepancies in serum grouping (particularly when tile grouping) and occasionally in cell grouping when using whole blood, unwashed or insufficiently washed red cells.

Rouleaux can usually be distinguished from true agglutination by examining the red cells microscopically. When suspected, add a drop of saline to the cells. Rouleaux usually disperses after 1–2 minutes following the addition of saline. Serum grouping should be repeated using serum diluted 1 in 2 in saline (mix 1 drop of saline with 1 drop of serum). This will cause rouleaux to disperse.

#### *Autoagglutinins*

Occasionally a patient's serum may contain autoagglutinins which are antibodies that cause the agglutination of a person's own and other red cells (autoagglutination). They are known to occur in lymphoma, leukaemia, virus pneumonia, systemic lupus erythematosus and other autoimmune diseases, and occasionally in severe falciparum malaria. Autoagglutination may also occur following treatment with some herbal preparations. Cold agglutinins active at room temperature are a frequent cause of autoagglutination.

When autoagglutinins are present, a patient's red cells appear agglutinated before commencing grouping. This can be confirmed by setting up an autocontrol. When autoagglutination due to cold agglutinins is suspected, the cell grouping should be repeated after washing the patient's red cells in warm saline and the serum group and autocontrol read after incubation at 37°C. The autocontrol should then be negative.

#### *Faulty technique*

When it is possible that a technical error in blood grouping has occurred, repeat the cell and serum grouping (using a spun tube technique).

## RHESUS GROUPING

In countries where few people are Rh negative, the cost of routine Rhesus grouping donors and patients may not be affordable or the policy of the national blood transfusion service may be to Rhesus group only female patients (excluding elderly women), those with conditions requiring regular blood transfusion, and those belonging to ethnic groups with known higher Rhesus negative frequency.

To perform Rhesus grouping the following are required:

- Blood sample
- Anti-D serum
- Controls

#### *Blood sample*

The same blood sample as used for ABO grouping is used for Rhesus grouping. Follow the manufacturer's instructions supplied with the anti-D serum regarding the strength of patient's red cell suspension to use in a tube spun technique or tile technique.

#### *Anti-D serum*

When available use an IgM (complete) anti-D



because this enables Rhesus grouping to be performed with ABO grouping at room temperature. Most commercially available IgM anti-D sera are monoclonal (prepared from human hybridized cell lines) and able to detect weak antigen D (formerly called D<sup>U</sup>).

#### Controls

Rh positive red cells (preferably CDe/cde) and when available Rh negative cells (preferably cde/cde) should be used to check the performance of anti-D sera.

#### Rhesus grouping techniques

Follow carefully the technique supplied by the manufacturer of the anti-D serum.

#### Interpretation of results

Agglutination of red cells . . . . . Rh positive  
No red cell agglutination\* . . . . . Rh negative

\*Check negative reactions microscopically.

*Note:* When using a monoclonal IgM anti-D reagent there is no need to test Rh negative samples for weak antigen D.

#### Rhesus antibody testing

In hospitals where Rhesus grouping is being carried out on patients attending antenatal clinics, all Rh negative mothers should have their blood tested and monitored for Rhesus antibodies in the regional blood transfusion centre.

#### Other blood group systems

IgM and IgG antibodies associated with blood group systems other than the ABO and Rhesus systems are occasionally encountered when blood grouping and compatibility testing.

*Cold reacting autoantibodies:* These are the most frequently detected irregular antibodies causing difficulties in grouping (see previous text) and crossmatching but rarely of clinical importance. They include:

- Anti-M and anti-N IgM saline reacting antibodies belonging to the MNSs system. Anti-s and anti-S antibodies occur as IgG antibodies active at 37°C.
- Anti-P<sub>1</sub> IgM saline reacting antibody belonging to the P system. In tropical countries anti-P<sub>1</sub> antibodies are occasionally found in the serum of patients with hydatid disease or infection with *Opisthorchis* flukes. Anti-P antibodies often lyse red cells in the presence of complement.
- Anti-I IgM saline reacting antibody belonging to the I system, commonly found as a weak antibody in normal serum and occasionally as a strong cold agglutinin causing autoimmune haemolytic anaemia (cold type) in patients with acute pneumonia. Anti-I IgG antibodies can occur as cold agglutinins in some viral infections and diseases of the reticuloendothelial system.
- Antibodies of the Lewis system (anti-Le<sup>a</sup>, anti-Le<sup>b</sup>, anti-Le<sup>a+b</sup>) which are usually naturally occurring but can be

acquired. They react in saline (often lysing red cells in the presence of complement), albumin, and by the antiglobulin test (IAT).

- Antibodies of the Lutheran system: anti-Lu<sup>a</sup> is a saline reacting naturally occurring IgG antibody and anti-Lu<sup>b</sup> is an IAT reacting IgG antibody.

*Immune IgG 37°C reacting irregular antibodies:* These rare immune antibodies, reacting best by the indirect antiglobulin test (IAT) can cause transfusion haemolytic reactions and occasionally haemolytic disease of the newborn. They include:

- Anti-K antibody of the Kell system.
- Anti-Jk<sup>a</sup> and less commonly anti-Jk<sup>b</sup> antibodies of the Kidd system.
- Anti-Fy<sup>a</sup> and anti-Fy<sup>b</sup> (very rare) antibodies of the Duffy system.

*Note:* Irregular antibodies of clinical importance belonging to blood group systems other than those described above may also be found in patient's sera. Information on important blood group systems and gene frequencies in a given population can usually be obtained from national blood transfusion services.

## 9.4 Compatibility testing

### Purpose of compatibility testing

The purpose of compatibility testing (cross-matching) is to prevent a transfusing reaction by ensuring:

- The ABO group of the blood to be transfused is compatible with the patient's ABO group.
- There are no detectable irregular antibodies in the patient's serum that will react with the donor's red cells, causing their destruction or reducing their normal survival.

As discussed in subunit 9.1, blood should only be requested when it is absolutely necessary. The request must be in writing using a *Blood Transfusion Request Form* and it must be signed by the medical officer with responsibility for the patient's care. The following is an example of a Request Form suitable for use in district hospitals.

*Note:* When the patient has been transfused before, laboratory staff should check the patient's notes and laboratory records, noting the reason for the trans-

fusion, whether any antibody was detected and whether any adverse reaction occurred during or following the previous transfusion.

<b>Blood Transfusion Request Form</b>	
Patient's name .....	Age .....
Hospital Number .....	Ward .....
Reason for transfusion .....	
.....	
<b>Requirement</b>	
Concentrated red cells, amount .....	
Whole blood, amount .....	
Date and time required .....	
<b>History</b>	
Has the patient been transfused before? .....	
Blood group (when known) .....	
Previous pregnancies .....	
Signed .....	
Date .....	

#### *Patient's blood sample*

For blood grouping and compatibility testing, collect blood into EDTA anticoagulant (see subunit 8.3) and 5–7 ml into a dry clean glass tube (not plastic). Label the containers *clearly* with the patient's name, hospital number, ward, and date. The EDTA blood is used to obtain red cells for cell grouping and to measure the patient's haemoglobin or packed cell volume. Serum from the clotted blood sample is used for serum grouping and compatibility testing.

When blood is collected in advance, the serum used to perform the compatibility test must not be more than 48 hours old. Serum used for compatibility testing should be kept by the laboratory for 3 days following a transfusion in case it is needed for re-testing in the unlikely event of a transfusion reaction. When blood is held for a patient who has been transfused, it must be re-crossmatched when more than 48 hours have passed since the first transfusion.

*Important:* When blood is collected by ward staff and delivered to the laboratory with the *Blood Transfusion Request Form*, the laboratory must check *carefully* that the name and hospital number on the blood sample are clear and the same as those on the request form, and that the questions on the form have been answered. Most errors that occur in

blood transfusion work involve patient misidentification often due to incorrect labelling of samples or collecting blood from the wrong patient.

#### **Selecting blood for transfusion**

As explained in subunit 9.1, in some situations it is more appropriate to use concentrated red cells rather than whole blood.

\*The preparation of concentrated red cells is described at the end of this subunit.

Fresh blood, not more than 2–3 days old, is required when transfusing infants and patients with conditions that require regular transfusion, e.g. thalassaemia patients to ensure the transfused red cells survive as long as possible in the patient. In district hospitals, in the absence of specific blood components, fresh blood is also used to treat patients with bleeding disorders.

#### *Blood group to use*

The first choice of blood for a patient should be blood of the same ABO group (and when applicable, Rhesus group) as the patient. Avoid transfusing group O blood to those who are not group O, particularly when needing to use whole blood because group O blood can contain dangerous immune anti-A and anti-B haemolysins (particularly in tropical countries). The risk is reduced when using concentrated red cells. When no blood or insufficient blood of the same ABO group as the patient is available, select blood as shown in the following chart.

<i>Group of patient</i>	<i>Choice of blood</i>			
	<b>1st</b>	<b>2nd</b>	<b>3rd</b>	<b>4th</b>
Group A	Gp A	Gp O	–	–
Group B	Gp B	Gp O	–	–
Group O	Gp O	–	–	–
Group AB	Gp AB	Gp A*	Gp B	Gp O

\*Group A is the second choice of blood because anti-B in Gp A blood is likely to be weaker than anti-A in Gp B blood.

*Note:* ABO and Rhesus grouping techniques are described in subunit 9.3.

#### **Compatibility testing**

A compatibility test is a final check on the compatibility of blood for a patient, particularly ABO compatibility. Several techniques are available for crossmatching blood to detect ABO incompatibility and clinically important irregular antibodies in a

patient's serum. Compatibility testing is *essential* when prior antibody screening is not performed (situation in most district laboratories due to unavailability of cell panels). In district laboratories, a simple to perform *single* tube technique comprising the following three stages is recommended:

- *Detection of ABO incompatibility in saline at room temperature:* Donor's cells are mixed with patient's serum at room temperature, centrifuged and examined visually for agglutination. When there is no agglutination or haemolysis, proceed to next stage.
- *Detection of antibodies agglutinating at 37°C in saline.* The tube is incubated at 37°C for 20 minutes, recentrifuged and examined for agglutination. When there is no agglutination or haemolysis, proceed to the third stage.
- *Detection of immune IgG antibodies that have sensitized donor's cells and are only agglutinated by using antiglobulin (AHG) reagent:*\* An indirect antiglobulin test (IAT) is performed in which red cells after being incubated in patient's serum are tested after washing for bound antibody.

\*When AHG is not available, the use of low ionic strength saline (LISS) is recommended. Only when AHG and LISS are not available should an albumin technique be used. AHG is recommended because some immune IgG antibodies and weak antibodies will only react when using an indirect AHG technique. An albumin technique will detect most anti-D antibodies, some other Rhesus antibodies and irregular antibodies, but it is not as sensitive as the AHG technique and will miss some antibodies.

*Note:* AHG-impregnated gel systems are commercially available for the rapid detection of antibodies but they are very expensive and have a shelf-life of only 1 year from manufacture.

### Single tube compatibility technique using AHG reagent

The following are required:

- Patient's serum
- Donor's washed 3% red cell suspension prepared as follows:
  - Transfer 0.2–0.5 ml of red cells from the pilot tube of the donor blood into about 5 ml of physiological saline (Reagent No. 68) and mix.
  - Centrifuge at high speed (e.g. 1 000 g) for about 2 minutes. Discard the supernatant fluid and resuspend the cells in a further 5 ml of saline. Mix, centrifuge, and discard the supernatant fluid.

- Prepare a 3% red cell suspension by adding 1 volume of packed cells to 30 volumes of saline.
- Antiglobulin polyspecific (Broad-spectrum) reagent, usually colour coded green. AHG reagent will agglutinate red cells sensitized with antibodies and/or coated with detectable levels of complement components.
- Anti-D serum (see subunit 9.3) to make AHG control cells.
- AHG control IgG sensitized red cells, prepared as follows:
  - Wash group O Rh positive red cells (obtained from a group O Rh positive person) three times in saline. Discard the final saline supernatant fluid.
  - Add an equal volume of IgG anti-D to the packed red cells and mix.
  - Incubate at 37°C for 30 minutes. Wash the cells four times in saline. Remove the final supernatant fluid.
  - Suspend the packed cells in saline to make a 5% red cell suspension. When added to AHG reagent, the sensitized cells should show visible agglutination (+++).
  - Store the sensitized cells at 2–8°C. They can be kept for 2–3 days.

### Method

- 1 Label a small (e.g. 75 × 12 mm) clean glass tube with the number of the donor blood and write this number also on the patient's blood transfusion request form.
- 2 Pipette 3 volumes of patient's serum into the tube.
- 3 Add 1 volume of donor's washed 3% red cell suspension and mix.
- 4 Centrifuge at *slow* speed e.g. at 150 g for 1 minute or 500 g for 10 seconds.
- 5 Tilting the tube back and forth, examine for haemolysis or agglutination.

### Important

Haemolysis or agglutination means that the donor blood is *ABO incompatible*. The blood **MUST NOT BE GIVEN TO THE PATIENT**.

When there is haemolysis or agglutination, recheck the ABO group of the patient and

donor blood (see subunit 9.3), and also check that the correct patient's blood sample has been tested.

- 6 When there is no agglutination, mix the contents of the tube and incubate at 37°C for 20–30 minutes.

**37°C incubation:** When a hospital does not have mains electricity to operate a water bath or heat block, incubation at close to 37°C can be achieved by using a *Thermos* flask (preferably wide-necked).

- 7 Centrifuge at *slow* speed. Tilting the tube back and forth, examine for haemolysis or agglutination.

*Haemolysis or agglutination indicate that the blood is incompatible and must not be given to the patient.*

- 8 When there is no haemolysis or agglutination, perform an indirect AHG test. Fill the tube with saline, centrifuge (high speed), and remove the supernatant fluid. Wash the cells a *further 3 times*. At the end of the final wash remove *all* the supernatant fluid.

*Note:* Careful washing of the cells is *essential*. Traces of globulin left in the tube will neutralize the AHG reagent.

- 9 Resuspend the cells by tapping the bottom of the tube. Add 2 drops of AHG reagent and mix.

- 10 Centrifuge at *slow* speed, e.g. at 150 g for 1 minute or at 500 g for 10–15 seconds.

- 11 Tilting the tube back and forth, look for agglutination. When no agglutination is seen, transfer a few of the cells to a slide and check for agglutination microscopically using the 10× objective. When there is no agglutination, check that the AHG has not been neutralized by adding 1 drop of AHG control sensitized cells to the tube. Repeat steps 10–11. The control cells will show agglutination, providing the AHG is active and the test has been performed correctly.

*When there is agglutination after adding AHG reagent, this means that the patient's serum contains an immune IgG antibody reactive against the donor's cells which may cause a transfusion reaction.*

*Note:* Other blood of the correct group should be checked for compatibility and the medical

officer notified. When possible, the nearest blood transfusion centre should be asked to identify the antibody and provide compatible blood. Most clinically important IgG antibodies can be detected by the indirect AHG test (see end of subunit 9.3).

- 12 Enter the test results in the *Blood Transfusion Records Book*.

#### **Single tube compatibility technique using AHG reagent and LISS to reduce incubation time**

The technique is performed as described above except that at step 6, before the incubation stage, add 3 drops of LISS to the tube. This has the advantage that the incubation time can be reduced to 15 minutes.

*Note:* LISS (low ionic strength saline) reagent is best purchased ready-made. It is not easily made in district laboratories. The pH of the reagent must be within the range 6.65–6.85, osmolality between 270–285 mmol and its conductivity between 3.5–3.8 mS/cm at 23°C.

#### **Compatibility testing using a saline and albumin technique**

A saline and albumin technique is appropriate to use when it is not possible to obtain AHG reagent. The following are required:

- Patient's serum
- Donor's washed 3% red cell suspension, prepared as described previously
- Bovine albumin 20%\*

\*Purchase as a 20% solution or prepare from a 30% solution (dilute with sterile distilled water, e.g. mix 6.6 ml 30% albumin with 3.4 ml water). Store at 2–8°C. It can be kept for several months providing it does not become contaminated.

#### **Method**

- 1 Label two small (e.g. 6.3 × 9.5 mm) tubes with the number of the donor blood and write this number also on the patient's transfusion request form.
- 2 Pipette 1 volume of patient's serum into each tube. Add 1 volume of donor's 3% cell suspension to each tube and mix.
- 3 Incubate one tube at 37°C for 45 minutes.
 

**37°C incubation:** When a district laboratory does not have mains electricity to operate a water bath or heat block, incubate the tube in a *Thermos* flask containing water at 37°C. A wide neck flask is easier to use.
- 4 Centrifuge the second tube at *slow* speed, e.g. 150 g for 1 minute or 500 g for 10–15 seconds. Tilting the tube back and forth, examine for haemolysis or agglutination.

**Suggested layout for a Blood Transfusion Records Book**

*Left hand page*

*Right hand page*

RECIPIENT

CROSSMATCH RESULTS and ISSUE OF BLOOD

Date	Patient's Name	Hospital Number	Ward	Group of Patient	Unit number	Group	Saline RT 37 °C	AHG (Albumin)	E <sup>1</sup>	Signed <sup>2</sup>	Pc <sup>3</sup> Wb	Expiry date	Issued <sup>4</sup> Signed

*Notes:* 1 Column E is ticked when blood is issued following an emergency crossmatch. 2 This column is signed by the person who performs the crossmatch. 3 Pc is entered when packed cells are issued and Wb when whole blood is issued. 4 The date the blood is issued is recorded and also the name of the person collecting the blood from the laboratory.

**Important**

Haemolysis or agglutination means that the donor blood is ABO *incompatible*. The blood **MUST NOT BE GIVEN TO THE PATIENT**.

When there is haemolysis or agglutination, recheck the ABO group of the patient and donor blood (see subunit 9.3) and also check that the correct patient's blood sample has been tested.

- 5 At the end of 45 minutes incubation, add carefully 1 drop of 20% albumin to the second tube, *allowing the reagent to run down the side of the tube*. Do not mix. Incubate for a further 10–15 minutes.
- 6 Look for agglutination in the albumin tube by carefully tilting the tube back and forth. When no agglutination is seen, transfer some of the cells to a slide and check for agglutination microscopically.

*When there is agglutination in the albumin tube this means that the patient's serum contains an immune IgG antibody reactive against the donor's cells which may cause a transfusion reaction.*

*Note:* Other blood of the correct group should be checked for compatibility and the medical officer notified. When possible, the nearest blood transfusion centre should be asked to identify the antibody and provide compatible blood.

**Agglutination in the albumin tube:** This is often caused by anti-D, other Rhesus antibodies, and occasionally antibodies of the Lewis, MNSs, Lutheran and P blood systems. The albumin technique is not as sensitive as an AHG technique and will miss some antibodies, e.g. weak reacting antibodies, most antibodies of the Kell, Kidd and Duffy blood systems, and most anti-S and anti-s antibodies. Agglutination in the albumin tube is also seen when there is an ABO incompatibility (first detected in the saline room temperature tube).

7 Enter the test results in the *Blood Transfusion Records Book*.

**Emergency compatibility testing**

In an emergency, blood is issued after completion of the first stage of a standard crossmatch, i.e. after centrifuging the saline room temperature tube and checking for haemolysis or agglutination to exclude ABO incompatibility. *This takes about 10 minutes* and therefore even when blood is urgently required it should be possible to perform this important part of a crossmatch.

*Note:* The risk to a patient when blood is transfused that has only been ABO checked is low when the patient has never been transfused previously or been pregnant. The level of risk to previously transfused patients and to those that have been pregnant depends on the frequencies in a population of the Rhesus and other blood group systems which can stimulate clinically important antibodies. Information on the frequency of important irregular antibodies which can be found in patients' sera can usually be obtained from national blood transfusion services.

*Note:* When blood is issued after excluding ABO incompatibility *only*, this must be indicated on the label attached to the blood pack and the *crossmatch must be completed*.

**Difficulties in crossmatching**

Most of the problems which can occur when crossmatching are those which will have already been met when blood grouping, providing both cell *and* serum grouping have been performed. They include rouleaux and cold reacting autoagglutinins. Bacterially contaminated donor cells can also cause difficulties when crossmatching.

*Rouleaux*: The causes of rouleaux and its identification have been described in subunit 9.3.

*Autoagglutinins*: As explained in subunit 9.3, autoantibodies in a person's serum can cause agglutination of a person's own red cells and other red cells. Most autoantibodies are cold reacting (see end of subunit 9.3). To make sure agglutination in the saline tube is caused by cold agglutinins, place the tube at 37°C for about 10 minutes. After incubation, the agglutination will have disappeared or become much weaker. Set up an autocontrol (patient's serum with their own red cells) at room temperature.

*Infected donor cells*: When bacterially contaminated donor's red cells are used in a compatibility test, the donor's cells will panagglutinate. It is important therefore never to use donor red cells that appear partially haemolyzed, dark in colour, or have an abnormal odour. Contamination rarely occurs in the pilot tubing of a blood pack. It is more likely to occur when donor samples are stored in another refrigerator (to avoid frequent opening of a gas operated blood bank refrigerator). When contamination of the donor cells is suspected, collect another sample from the pilot tubing of the blood pack after first checking the blood pack itself for signs of contamination, e.g. haemolysis in the plasma.

### Labelling compatible blood

When blood has been crossmatched and found to be compatible, a *Crossmatch Label* must be attached to the blood pack preferably using a tie on label. If using an adhesive label, secure it with an elastic band. Information on the label must be clear and include the patient's name, hospital number, ward, blood group of the patient, number of the blood unit, group of the blood, and its expiry date. The label should be signed by the person who has carried out the crossmatch.

### Issuing crossmatched blood

When issuing blood for a patient *it is the responsibility of laboratory staff*:

- 1 To ensure the correct blood is issued for a patient. To do this, the person collecting the blood must bring to the laboratory the patient's notes or a sheet from the notes on which is written the patient's name *and* hospital number. This information must be checked against the label on the blood unit. Ask the person collecting

#### EMERGENCY CROSSMATCH

Patient ..... Ward.....  
Hospital Number ..... Date.....  
Group of patient.....

##### Crossmatch

This blood has been found compatible by an EMERGENCY Crossmatch which excludes an ABO incompatibility

Unit number ..... Group.....  
Expiry date .....

Signed .....

#### STANDARD CROSSMATCH

Patient ..... Ward.....  
Hospital Number ..... Date.....  
Group of patient.....

##### Crossmatch

This blood has been found compatible by a standard crossmatch

Unit number ..... Group.....  
Expiry date .....

Signed .....

the blood also to check this information and then to sign and date the *Blood Transfusion Record Book*.

- 2 To inspect the condition of the blood and NOT TO ISSUE IT when there are signs of bacterial contamination as indicated by haemolysis (red colouring in the plasma, particularly in the plasma just above the red cells), darkening in colour of the red cells and, or, presence of clots. Check also whether the blood pack has been damaged and is leaking blood.
- 3 To ensure that the blood group written on the blood unit (at the time the donor blood is grouped) is compatible with the group written on the crossmatch label attached to the blood bag.
- 4 To check that the blood is within its expiry date.
- 5 To ensure packed cells are issued when these

have been requested. After issuing the blood, record that it has been removed from the refrigerator (see Blood Bank Record Sheet).

*Important:* Blood that is not used and has been stored outside the blood bank for more than 30 minutes cannot be returned to the refrigerator for reuse unless the blood has been stored in a cold box with freezer packs (but not for more than 2 hours). Blood that is not used for a patient must be returned to the laboratory accompanied by a written note explaining why the blood has not been transfused.

### Preparation of concentrated (packed) red cells

In most blood transfusion centres, blood is collected into blood bags with an attached empty bag into which plasma can be transferred in a closed system after centrifuging the blood in a refrigerated centrifuge. When a district hospital is not supplied with red cell concentrates from a blood transfusion centre, concentrated red cells can be prepared after storing blood packs in an upright position in the blood bank and the cells have sedimented (after about 8 hours). When using a single bag blood pack, a manually operated plasma extractor device can be used to remove the plasma or when this is not available the bag can be squeezed to remove the plasma as shown in Plate 9.5 using the following technique:

- 1 Place the blood bag against a wall (preferably behind a sink).
- 2 Clamp the tubing about half way down its length.
- 3 Break the seal between the tubing and the bag.



Plate 9.5 Preparing concentrated red cells when a plasma extractor is not available. *Courtesy of Denise Hill*

Place the end of the tubing in a container in the sink and cut the end.

- 4 Press the bag as shown in Plate 9.5, and release the clamp. The plasma will start to flow.
- 5 When 20–30 mm of plasma remains, *while still pressing the bag*, clamp the tubing (air *must not* be allowed to enter the bag).
- 6 Seal the end of the tubing with a sealing clip or knot it tightly. Dispose of the plasma safely.

Concentrated red cells are best prepared at the time they are required because red cells do not keep well once the plasma is removed. When stored at 2–8 °C they can be used for up to 24 hours.

### Investigation of a transfusion reaction

A severely anaemic patient may react adversely to a blood transfusion when blood is transfused too quickly or too much whole blood is transfused causing circulatory overload. Most reactions to transfused blood are minor non-haemolytic febrile reactions causing shivering and a slight rise of temperature. Malaria parasites will often cause a temperature rise and also antibodies to leukocytes or platelets. Occasionally allergic anaphylactic reactions occur with urticaria (skin rash) and sometimes bronchial spasm due to hypersensitivity to plasma protein antigens. Allergic reactions are less common when using concentrated red cells.

#### *Haemolytic transfusion reactions*

The most serious often fatal transfusion reactions are caused by:

- Transfusing ABO incompatible blood due to patient misidentification, incorrect labelling of specimens, or serological errors made in the laboratory. ABO incompatibility is due to IgM anti-A and, or, anti-B antibodies in a patient's serum reacting with antigen A and, or, antigen B on transfused red cells, causing intravascular haemolysis (due to complement lysis) with haemoglobinaemia and jaundice. ABO haemolytic transfusion reactions may be fatal with patients dying from bleeding, renal failure, and shock.

**Beside ABO Compatibility check before blood is transfused:** In some countries it is the practice to recheck a patient's ABO group and the ABO group of the donor blood immediately before transfusing the blood. This is usually done by using a bedside ABO compatibility card, e.g. *Diagnost Laboratories Bedside Card* which is impregnated with anti-A and anti-B antisera, or by using liquid anti-A and anti-B reagents.

- Transfusing infected blood, commonly caused by inadequate cleansing of the venepuncture site when collecting blood from a donor. Blood can also become infected when air is allowed to enter a blood bag, e.g. when the same unit of blood is used to transfuse several children on successive days.
- Transfusing blood which has expired, has been haemolyzed by being stored next to the freezing compartment of a refrigerator, or has been stored at temperatures higher than 8 °C.

#### *Haemolytic reactions due to IgG antibodies*

Transfusion reactions due to immune IgG antibodies are usually less serious, mainly causing extravascular haemolysis (predominantly in the spleen) with the reduced survival of transfused red cells. Often a patient's haemoglobin falls several days after the transfusion and the patient may become jaundiced.

#### **Action to take when a transfusion reaction occurs**

When a reaction occurs the transfusion must be stopped and the attending medical officer notified immediately and also laboratory personnel. There should be a standardized procedure for investigating a transfusion reaction and recording clinical and laboratory findings. The laboratory investigations should include:

- 1 Collecting the blood pack and checking that the patient has received the correct blood and that there has been no error due to incorrect labelling or misreading of names or hospital numbers.

*Important:* When a clerical error is detected, an urgent check must be made to make sure no other patient is involved.

- 2 Collecting 5–10 ml of venous blood from the patient and also an EDTA blood sample. The first urine passed by the patient should be sent to the laboratory.

Check for haemolysis by:

- Examining a stained blood film for spherocytosis and red cell fragmentation.
- Centrifuging the EDTA blood and examining the plasma for haemolysis.
- Testing the urine for haemoglobin (see pp. 381–382 in Part 1 of the book) and examining it microscopically for cellular casts.
- Checking for DIC by performing a platelet count and when possible an FDP test (see subunit 8.11).

- 3 Testing pre- and post-transfusion samples and the donor blood for ABO incompatibility.

*Check for incompatibility by:*

- Re-grouping the pre-transfusion patient's sample.
- Grouping the patient's post-transfusion sample.
- Re-grouping the donor blood.
- Repeating the crossmatch with the patient's pre-transfusion and post-transfusion samples.

- 4 Examining the blood for bacterial contamination.

*Check for bacteria in the blood by:*

- Examining a Gram stained smear of the blood from the blood pack. When bacteria are the cause of a reaction, usually they will be plentiful and easily seen. When cultures are performed these should be carried out at 2–8 °C, room temperature, and 37 °C.
- Examining plasma from a centrifuged sample of the blood pack for haemolysis.

*Important:* All test results must be recorded clearly, preferably using a standardized *Blood Transfusion Reaction Investigation Form*.

## **HAEMOLYTIC DISEASE OF THE NEWBORN**

The term haemolytic disease of the newborn (HDN) is used to describe an immune haemolytic anaemia which causes an infant to be born anaemic and jaundiced. In most tropical countries, HDN is three times more likely to be caused by ABO incompatibility than Rhesus incompatibility due to the low number of Rh negative women in African and Asian populations (see subunit 9.3).

#### **Other more common causes of neonatal jaundice in tropical countries.**

Neonatal jaundice is often multifactorial, with prematurity, sepsis, and G<sub>6</sub>PD deficiency alone or in combination accounting for about 85% of neonatal jaundice in Africa, Southeast Asia and Papua New Guinea.

#### **HDN due to ABO incompatibility**

This can occur when a mother who is group O with a high titre of immune IgG anti-A and anti-B (usually >1 in 64) in her serum becomes pregnant with a group A or group B infant. IgG anti-A and anti-B cross the placenta and enter the fetal circulation, causing destruction of fetal red cells. Group B infants are often more severely affected than Group A infants. When HDN due to ABO incompatibility is suspected and requires investigation, the laboratory should perform the following:



- ABO cell grouping of the infant using washed cord cells. When the infant is group A or group B, carry out the following tests:
- Check whether there is maternal-infant blood group incompatibility as follows:
  - Pipette 2 volumes *fresh* serum from the mother into a tube.
  - Add 1 volume of infant's washed 5% cell suspension and mix.
  - Incubate at 37°C for 15 minutes. Centrifuge at slow speed e.g. 150 g for 1 minute or at 500 g for 10 seconds.
  - Examine the tube for haemolysis.
  - Lysis of the red cells indicates ABO HDN.
- Perform a direct antiglobulin test (DAT) on the infant's red cells to check whether they have been coated with IgG antibody:

#### **DAT method**

- Wash a 3% suspension of the infant's red cell four times in physiological saline (Reagent No. 68). Decant the final supernatant fluid.
- Resuspend the packed cells. Add two volumes of AHG reagent and mix.
- Centrifuge slowly for 1 minute. Tilting the tube back and forth, examine for agglutination. When there is no agglutination, transfer a small number of cells to a slide and examine microscopically for agglutination. Ensure that the AHG is active by adding 1 drop of IgG AHG control cells to the tube as explained previously for the indirect AHG test.
- A positive DAT indicates antibody coating of the infant's red cells. In tropical countries most infants with severe ABO HDN give a positive DAT.
- Check the haemoglobin and serum bilirubin of the infant. Examine a Romanowsky stained blood film from the infant for features of HDN. The blood film will show spherocytosis which may be marked, polychromasia (due to reticulocytosis) and nucleated red cells (see colour Plate 114).

*Note:* ABO HDN is rarely sufficiently severe to require an exchange blood transfusion. In a situation in which it is indicated, Group O blood (of the same Rhesus group as the baby) should be selected and *crossmatched with the mother's serum*. In contrast to

Rhesus HDN, ABO HDN may occur in the first pregnancy and may or may not affect subsequent pregnancies depending on the ABO group of the infant.

#### **HDN due to Rhesus incompatibility**

Rhesus HDN is usually caused by immune anti-D and less commonly by other Rhesus antibodies. It occurs when a Rh negative mother with circulating IgG anti-D antibody (formed from a previous Rhesus incompatible pregnancy) becomes pregnant with a Rh positive infant and IgG anti-D passes into the fetal circulation, destroying fetal cells. The infant can be born severely anaemic and jaundiced. The severity of disease increases with each Rh positive pregnancy. Infants with Rhesus HDN are usually more severely affected than infants with ABO HDN.

*Note:* In most cases of Rhesus HDN, maternal IgG anti-D will have been detected by the laboratory during routine antenatal visits, and the strength of the antibody (titre), monitored.

When Rhesus testing is not performed routinely (due to low frequency of Rh negative persons in the population) and an infant is born severely anaemic and jaundiced, the laboratory may be asked to investigate the possibility of Rhesus HDN:

- 1 ABO and Rh group the mother and infant.  
There can be no Rhesus incompatibility caused by anti-D antibody unless the mother is Rh negative and the infant is Rh positive.  
*Note:* Occasionally, when grouping the infant's cells they may not appear Rh positive when antigen D receptors on the baby's cells have been coated with maternal anti-D.
- 2 Carry out a DAT on the infant's cord cells as described previously under ABO HDN. The DAT will be positive in Rhesus HDN.
- 3 Measure the infant's haemoglobin and serum bilirubin (see pp. 350–355 in Part 1 of the book).  
*Note:* With Rhesus HDN, the infant's haemoglobin is usually below 140 g/l (14 g/dl) and the serum unconjugated bilirubin may rise to over 340 µmol/l (20 mg%). Such high levels of unconjugated bilirubin can cause irreversible brain damage (kernicterus).
- 4 Examine a Romanowsky stained blood film for the features of HDN, including spherocytosis which is usually less marked than in ABO HDN, polychromasia (reticulocytosis) and many nucleated red cells.
- 5 Test also the mother's serum for anti-D antibody when this has not been tested previously.

*Exchange blood-transfusion*

When the haemoglobin level of an infant with Rhesus HDN continues to fall and the unconjugated bilirubin to rise to dangerous levels, the laboratory may be requested to prepare blood for an exchange transfusion. This will help to treat the anaemia, lower the bilirubin level and remove sensitized red cells from the infant's circulation.

The blood used in an exchange transfusion must be negative for the antigen against which the maternal antibody is reactive, e.g. when the antibody is anti-D, ABO compatible Rh negative blood must be used *The mother's serum must be used in the crossmatch*. When a mother's serum is incompatible with the infant's ABO group, group O blood should be used. When the groups are the same then the choice of blood should be that to which the baby and mother belong. The selection of blood can be summarized as follows:

Mothers Group	Infant 's group	ABO Blood group to use
O	A, B or O	Group O only
A	A or AB O or B	Group A or O Group O only
B	B or AB O or A	Group B or O Group O only
AB	A B AB	Group A or O Group B or O Group A, B, AB or O

For an exchange transfusion, fresh blood should be used (not more than 3 days old).

*Note:* Whenever possible an infant with severe Rhesus HDN and mother should be transferred from a district hospital to a hospital with specialist facilities and access to a blood transfusion centre.

---

#### FURTHER INFORMATION & RECOMMENDED READING

**Lewis SM et al.** *Laboratory aspects of blood transfusion: Ch 20 in Practical Haematology*, 9th edition, 2001, Churchill Livingstone.

**Mvere DA** A strategy for blood safety in the Africa region. *Africa Health*, July 2002.

**Nyamongo J.** From a hospital-based blood bank system to a centralised system: the Kenyan experience. *Africa Health*, July 2002.

**Kataha P.** Transfusion of blood and blood components: obtaining value from a crucial commodity. *Africa Health*, July 2002.

#### WHO

*Safe blood and blood products*

Highly recommended Distance Learning Materials, 2nd edition ISBN 92 41545461, 2002. Order No 1150490. Available in English, Spanish, Portuguese, French, Chinese, from WHO Publications, WHO 1211, Geneva, 27-Switzerland. Consists of 5 separate comprehensive booklets:

- Introductory module: Guidelines and principles for safe blood transfusion practice.
- Module 1: Safe blood donation.
- Module 2: Screening for HIV and other infectious agents.
- Module 3: Blood group serology (covering basic blood group immunology, ABO and Rhesus blood group systems, compatibility testing).
- Trainer's guide

*Clinical use of blood in medicine, obstetrics, paediatrics, surgery, anaesthesia, trauma and burns.* World Health Organization, Blood Transfusion Safety, Geneva, 2001. ISBN 92 41545380.

*The Blood Cold Chain – Guide to selection and procurement of equipment and accessories,* World Health Organization, Geneva, 2002. ISBN 92 41545798.

#### FROM WHO/ESSENTIAL HEALTH TECHNOLOGIES

*Aide-Memoire* (website [www.who.int](http://www.who.int), use Search facility)

- The clinical use of blood, WHO/EHT/04.07, 2004.
- Quality systems for blood safety, WHO/BCT/02.02, 2002.
- Blood safety, WHO/BCT/02.03, 2002.

#### WEBSITE

Blood Transfusion safety website [www.who.int/bct](http://www.who.int/bct)

#### INTERNATIONAL FEDERATION of RED CROSS and RED CRESCENT SOCIETIES

*Making a difference: recruiting voluntary, non-remunerated blood donors,* International Federation of Red Cross and Red Crescent Societies, 2002.

#### NEWSLETTER

*Donor Recruitment International Newsletter* (free of charge), published by International Federation of Red Cross and Red Crescent Societies. PO Box 372, CH-1211, Geneva, 19-Switzerland. Tel: +41(22) 730 42 22 Fax: +41 (22) 733 03 95 E-mail: [secretariat@ifrc.org](mailto:secretariat@ifrc.org) Website: [www.ifrc.org](http://www.ifrc.org)

The Newsletter is published three times a year. It provides information on scientific and practical aspects of transfusion medicine including news on individual blood programmes and blood donor recruitment campaigns.

---

## RECOMMENDED BOOKS FOR PART 2

## MICROBIOLOGY

**Cook G, Zumla A.** *Manson's tropical diseases*, 21st edition, 2003. WB Saunders Company, Elsevier.

**Shears P, Hart T.** *Atlas of Medical Microbiology*, 2nd edition, 2004. Mosby, Elsevier.

**Greenwood D, Slack R, Peutherer J.** *Medical microbiology – Guide to microbial infections: pathogenesis, immunity, laboratory diagnosis and control*, 16th edition, 2002. Churchill Livingstone, Elsevier.

**Collins CH, Lyne PM, Grange JM.** *Collins & Lyne's Microbiological methods*. 8th edition 2004. Arnold publishers.

**Tinbury MC et al.** *Notes on Medical Microbiology, 2002*. Churchill Livingstone, Elsevier.

**Struthers JK, Westran RP.** *Clinical bacteriology* (colour illustrated text), 2003. Manson publishing.

**WHO** *Basic laboratory procedures in clinical bacteriology*, 2nd edition, 2003. World Health Organization, Geneva.

**Perilla M et al.** *Manual for the laboratory identification and antimicrobial susceptibility testing of bacterial pathogens of public health importance in the developing world*. WHO/CDC, 2003. CDS Information Resource Centre, World Health Organization, Geneva.

**WHO** *TB/HIV – A Clinical Manual*, 2nd edition, 2004. World Health Organization, Geneva.

**Webber R.** *Communicable disease epidemiology and control: A global perspective*, 2nd edition, 2005. CABI Publishing.

**WHO.** *AIDS in Africa*, 2005. World Health Organization, 2005.

**Hubley J.** *AIDS Handbook*, 2nd edition, revised, 2002, Macmillan.

**Dyck E Van, Meheus AZ, Piot P.** *Laboratory diagnosis of sexually transmitted diseases*, 1999, World Health Organization, Geneva.

**Sanborn WR et al.** *Fluorescence microscopy for disease diagnosis and environmental monitoring*, 2005, World Health Organization, Geneva.

## HAEMATOLOGY and BLOOD TRANSFUSION

**Lewis SM, Bain BJ, Bates I.** *Practical haematology*, 9th edition, 2001. Churchill Livingstone, Elsevier.

**Provan D et al.** *Oxford handbook of clinical haematology*, 2nd edition, 2004. Oxford University Press.

**WHO** *Safe blood and blood products*, 2nd edition, 2002. Consisting of five separate booklets:

- Introductory module: Guidelines and principles for safe blood transfusion practice.
- Module 1: Safe blood donation.
- Module 2: Screening for HIV and other infectious agents.
- Module 3: Blood group serology (covering basic blood group immunology, ABO and Rhesus blood group systems, compatibility testing).
- Trainer's guide

Available from WHO Publications, WHO Geneva.

**WHO** *Clinical use of blood in medicine, obstetrics, paediatrics, surgery, anaesthesia, trauma and burns*. World Health Organization, Blood Transfusion Safety, 2001.

## HAEMATOLOGY WEBSITE

[www.haematology.org](http://www.haematology.org)

*Note:* Other sources of information and referenced papers are listed at the end of individual subunits.

## Part 1

### District Laboratory Practice in Tropical Countries

2nd edition 2005

#### CONTENTS

##### Chapter 1 Organization and staffing of district laboratory services

- Importance of the laboratory
- Training and continuing education
- District laboratory network
- Code of conduct

##### Chapter 2 Total quality management of district laboratory services

- Ensuring reliability and quality
- Preparing SOPs
- Quality assurance
- Selecting and reporting tests
- Controlling costs
- SI units

##### Chapter 3 Health and safety in district laboratories

- Safe laboratory premise
- Personal safety measures
- Microbial hazards
- Disposal of contaminated waste
- Equipment hazards
- Chemical hazards
- Fire safety
- Emergency First Aid

##### Chapter 4 Equipping district laboratories

- Purchasing equipment
- Power supplies
- Microscopy
- Centrifuge
- Autoclave
- Purifying water
- Weighing and mixing
- Pipetting and dispensing
- Incubator, water bath, heat block
- Colorimeter

##### Chapter 5 Parasitological tests

- Techniques
- *E. histolytica*, *G. lamblia*, *B. coli*
- Intestinal coccidia, *N. fowleri*
- *A. lumbricoides*, *T. trichiura*, hookworm, *S. stercoralis*, *E. vermicularis*
- *Schistosoma* species
- *Opisthorchis* species
- *F. hepatica*, *F. buski*
- *Taemia* species, *D. laturn*, *V. nana*
- Malaria parasites and RDTs
- Trypanosomes
- *Leishmania* species
- *W. bancrofti*, *Brugia* species, *L. loa*
- *O. volvulus*, *Paragonimus* species
- *Toxoplasma*, *E. granulosus*, *T. spiralis*
- *D. medinensis*

##### Chapter 6 Clinical chemistry tests

- Creatinine and urea
- Glucose
- Bilirubin
- Albumin
- ALT
- Amylase
- Sodium and potassium
- Urine tests
- c.s.f. tests
- Faecal tests

**Appendices:** Preparation of reagents, addresses, e-mails, websites, useful charts and figures.

**Supplement:** Training curriculum for district laboratory personnel.

# **Appendix I**

## **Preparation of Reagents and Culture Media**

## PREPARING REAGENTS AND CULTURE MEDIA

Guidelines on the preparation of stains and reagents can be found in subunit 2.6 in Part 1 of the book. The safe handling of chemicals and the use of hazard symbols are described in subunit 3.5 in Part 1. Guidelines on the preparation of culture media can be found in subunit 7.4.

*Note:* Deionized water can be used instead of distilled water. The term 'room temperature' as used in this Appendix refers to 20–28°C.

### Acetone-alcohol decolorizer No. 1

*To make 1 litre:*

Acetone . . . . . 500 ml  
Ethanol or methanol, absolute . . . . . 475 ml  
Distilled water . . . . . 25 ml

- Mix the distilled water with the absolute ethanol (ethyl alcohol) or methanol (methyl alcohol). \* Transfer the solution to a screw-cap bottle of 1 litre capacity.

\*Technical grade is adequate.

**Caution:** Ethanol and methanol are highly flammable, therefore use well away from an open flame.

- Measure the acetone, and add immediately to the alcohol solution. Mix well.

**Caution:** Acetone is a highly flammable chemical that vapourizes rapidly, therefore use it well away from an open flame.

- Label the bottle, and mark it *Highly Flammable*. Store in a safe place at room temperature. The reagent is stable indefinitely.

*For use:* Transfer a small amount of the reagent to a dispensing container that can be closed when not in use.

### Acetyl-cysteine solution No. 2

*To make about 100 ml:*

*Prepare FRESH before use*

N Acetyl-L-cysteine\* . . . . . 2.0 g  
Sodium hydroxide, 0.8% w/v\*\* . . . . . 100 ml

\*Available from Sigma chemicals.

\*\*Prepare by mixing 20 ml Reagent No 75 with 80 ml distilled water.

- Weigh the acetyl-cysteine. Transfer to a screw-cap container.
- Add the sodium hydroxide solution and mix until the chemical is completely dissolved.

*Note:* Use the same day of preparation.

### Acid alcohol, 1% v/v No. 3

This is a 1% v/v hydrochloric acid solution in 70% v/v alcohol.

Prepare from the 3% v/v solution by mixing 10 ml of Reagent No. 4 with 20 ml of water, or make as follows;

*To make 1 litre:*

Ethanol or methanol, absolute . . . . . 693 ml  
Distilled water . . . . . 297 ml  
Hydrochloric acid, concentrated . . . . . 10 ml

- Fill a 1 litre cylinder to the 693 ml mark with absolute ethanol (ethyl alcohol) or methanol (methyl alcohol). \* Add water to the 990 ml mark.

\*Technical grade is adequate.

**Caution:** Ethanol and methanol are highly flammable, therefore use these chemicals well away from an open flame.

- Add 10 ml of concentrated hydrochloric acid, i.e. to the 1 litre mark.

**Caution:** Concentrated hydrochloric acid is a corrosive chemical with an injurious vapour, therefore handle it with great care in a well ventilated room.

- Transfer the solution to a screw-cap bottle, and mix well.
- Label the bottle and mark it *Flammable*. Store at room temperature in a safe place. The reagent is stable indefinitely.

*For use:* Transfer a small amount of the reagent to a dispensing container that can be closed when not in use.

### Acid alcohol, 3% v/v No. 4

This is a 3% v/v hydrochloric acid solution in 70% v/v alcohol.

*To make 1 litre:*

Ethanol or methanol, absolute\* . . . . . 680 ml  
Distilled water . . . . . 290 ml  
Hydrochloric acid, concentrated . . . . . 30 ml

\*Technical grade is suitable.

- Measure the ethanol or methanol and transfer to a 1 litre capacity leak-proof container.

**Caution:** Ethanol and methanol are highly flammable, therefore use well away from an open flame.

- Measure the water, add to the alcohol, and mix.

- 3 Measure 30 ml of concentrated hydrochloric acid, add to the solution, and mix well.

**Caution:** Concentrated hydrochloric acid is a corrosive chemical with an injurious vapour, therefore handle it with great care in a well ventilated room.

- 4 Label the bottle, and mark it *Flammable*. Store at room temperature in a safe place. The reagent is stable indefinitely.

*For use:* Transfer a small amount of the reagent to a dispensing container that can be closed when not in use.

**Acid citrate dextrose (ACD) No. 5**  
*To make about 125 ml:*

Dextrose (glucose).....	3.0 g
tri-Sodium hydrogen citrate.....	2.0 g
Sterile distilled water.....	120 ml

- 1 Weigh the chemicals and transfer to a sterile screw-cap container.
- 2 Add the water and mix until the chemicals are completely dissolved.
- 3 Label the bottle and store at 2–8 °C. Renew if it becomes contaminated (appears turbid).

**Acridine orange acid stain No. 6**  
*To make 500 ml:*

Acridine orange.....	0.13 g
Acetic acid, glacial (concentrated).....	10 ml
Distilled water.....	490 ml

- 1 Weigh the acridine orange, and transfer to a brown bottle of 500 ml capacity.
- 2 Fill a cylinder to the 490 ml mark with distilled water. Add 10 ml of glacial acetic acid, i.e. to the 500 ml mark.

**Caution:** Glacial acetic acid is a corrosive chemical with an irritating vapour, therefore handle it with care in a well ventilated room. *Do not* mouth-pipette.

- 3 Add about half of the acid solution to the acridine orange, and mix until the dye is completely dissolved.
- 4 Add the remaining acid solution, and mix well.
- 5 Label the bottle, and store at room temperature. The stain is stable for several weeks.

**Albert's iodine solution No. 7**  
*To make 150 ml:*

Potassium iodide.....	1.5 g
Iodine.....	1.0g
Distilled water.....	150 ml

- 1 Weigh the potassium iodide, and transfer to a brown bottle premarked to hold 150 ml.
- 2 Add 30–40 ml of distilled water, and mix until the potassium iodide is *completely* dissolved.
- 3 Weigh the iodine, and add to the potassium iodide solution. Mix until the iodine is completely dissolved.

**Caution:** Iodine is injurious to health if inhaled or allowed to come in contact with the eyes, therefore handle it with care in a well ventilated room.

- 4 Make up to the 150 ml mark with distilled water, and mix well.
- 5 Label the bottle, and store in a dark place at room temperature. Renew the reagent when its colour fades.

**Alcohol fixative solution No. 8**  
*To make 200 ml:*

Ethanol (ethyl alcohol), absolute.....	180 ml
Acetic acid, glacial.....	10 ml
Distilled water.....	10 ml

- 1 Fill a cylinder (250 ml capacity) to the 180 ml mark with absolute ethanol. Add water to the 190 ml mark.

**Caution:** Ethanol is highly flammable, therefore use it well away from an open flame.

- 2 Add 10 ml of glacial acetic acid, i.e. to the 200 ml mark. Transfer the solution to a screw-cap bottle, and mix well.

**Caution:** Glacial acetic acid is a corrosive chemical with an irritating vapour, therefore use it in a well ventilated room. *Do not* mouth-pipette.

- 3 Label the bottle, and mark it *Flammable*. Store at room temperature in a safe place. The reagent is stable indefinitely.

*For use:* Immerse the smear in the fixative for 20 minutes. Rinse with 95% ethanol, and allow the smear to dry.

**Alcohol saline solution****No. 9***To make 250 ml:*

Ethanol or methanol, absolute . . . . . 5 ml  
 Sodium chloride, 8.5 g/l (0.85% w/v)\* . . . . 245 ml  
 (Physiological saline)

\*See Reagent No. 68.

- 1 Fill a cylinder (250 ml capacity) to the 245 ml mark with the saline solution.
- 2 Add 5 ml of absolute ethanol (ethyl alcohol) or methanol (methyl alcohol),\* i.e. to the 250 ml mark.

\*Technical grade is suitable.

**Caution:** Ethanol and methanol are highly flammable, therefore use these chemicals well away from an open flame.

- 3 Transfer to a screw-cap bottle, and mix well. Label the bottle, and store in a cool place. The reagent is stable for several months.

**Alkaline peptone water****No. 10***To make about 50 bottles:*

Peptone . . . . . 5 g  
 Sodium chloride . . . . . 5 g  
 Distilled water . . . . . 500 ml

- 1 Dissolve the peptone and sodium chloride in the water.
- 2 Adjust the reaction of the medium to pH 8.6–9.0 using 1 mol/l sodium hydroxide (Reagent No. 75).
- 3 Dispense the medium in 10 ml amounts in screw-cap bottles.
- 4 Sterilize by autoclaving (with caps loosened) at 121 °C for 15 minutes. Tighten the bottle caps after the medium has cooled.
- 5 Date the medium and give it a batch number. Label the bottles and record on each the expiry date of the medium (2 years from preparation).
- 6 Store in a cool dark place with the bottle caps screwed tightly to prevent a change in pH.

*Shelf-life:* Up to 2 years providing there is no change in the volume or appearance of the medium to suggest contamination.

*pH of medium:* This should be within the range pH 8.6–9.0 at room temperature.

**Inoculation**

*For use as an enrichment medium:* Inoculate with

3–4 loopfuls of faecal specimen and incubate at 35–37 °C for 5–8 hours. Subculture several loopfuls (from the surface) on to a plate of alkaline (pH 8.6) nutrient agar or preferably TCBS agar.

*For use as a transport medium:* Inoculate with about 1 ml of fluid specimen or with a rectal swab. The inoculated medium should reach the laboratory within 10 hours (*Proteus* species will grow eventually in alkaline peptone water).

**Amies transport medium****No. 11**

This medium is best prepared from ready to use dehydrated powder, available from most suppliers of culture media.

*Contents:* Charcoal, sodium chloride, phosphate buffer, potassium chloride, sodium thioglycollate, calcium chloride, magnesium chloride, agar.

The medium is usually used at a concentration of 2 grams in every 100 ml distilled water (concentration may vary depending on manufacturer).

- 1 Prepare as instructed by the manufacturer. Dispense the well-mixed medium in screw-cap Bijou bottles, filling each container. Sterilize by autoclaving (with bottle caps loosened) at 121 °C for 15 minutes.
- 2 When the medium has cooled, tighten the bottle caps. During cooling, invert the bottles to ensure an even distribution of the charcoal.
- 3 Date the medium and give it a batch number. Label the bottles and record on each the expiring date of the medium (9 months from preparation).
- 4 Store the medium in a cool place away from direct light with the bottle tops tightly screwed.

*Shelf-life:* Up to 9 months providing there is no change in the *volume or appearance* of the medium to suggest contamination, or an alteration of its pH.

*pH of medium:* This should be within the range pH 7.1–7.3 at room temperature. Test as described in subunit 7.4.

**Inoculation**

Clinic and ward staff should be advised to check the expiry date before using the medium. Collect the specimen on a sterile cotton wool swab and immerse it in the medium, cutting off the swab stick to allow the bottle top to be replaced tightly. Protect the swab from direct light and heat. It should reach the laboratory within 24 hours.



**Ammonia water, 0.4 ml/l (0.04% v/v) No. 12**  
*To make about 500 ml:*

Ammonia solution, concentrated . . . . . 0.2 ml  
 (SG 0.88)  
 Distilled water. . . . . 500 ml

- 1 Measure the water and transfer it to a screw-cap container.
- 2 Add 0.2 ml of ammonia solution and mix well.  
**Caution:** Ammonia solution is a corrosive chemical with an irritating vapour, therefore handle it with care in a well ventilated room. *Do not* mouth-pipette the chemical.
- 3 Label the bottle and store it at room temperature. The reagent is stable providing the cap of the bottle is kept tightly screwed.

**Ammonium oxalate, 10g/l (1% w/v) No. 13**  
*To make 100 ml:*

Ammonium oxalate. . . . . 1.0 g  
 Distilled water. . . . . 100 ml

- 1 Weigh the chemical and transfer it to a *completely clean* screw-cap container.
- 2 Add the water and mix until the chemical is completely dissolved. Label the bottle and store at 2–8°C.

*For use:* Filter immediately before use to ensure the reagent is free from particles which could be mistaken for platelets.

**Auramine-phenol stain No. 14**  
*To make 500 ml:*

Phenol crystals. . . . . 15 g  
 Auramine O . . . . . 1.5 g  
 Distilled water . . . . . to 500 ml

- 1 Weigh rapidly the phenol in a beaker.  
**Caution:** Phenol is a highly corrosive, toxic, hygroscopic chemical. Handle it with *great care*. To avoid spilling any of the corrosive chemical on the balance pan, remove the beaker each time the chemical is added or subtracted.
- 2 Measure the water. Add about 200 ml of the water to the phenol, and stir to dissolve. With care, transfer the phenol solution to a bottle premarked to hold 500 ml.
- 3 Weigh the auramine O and add to the bottle. Mix well to dissolve the stain. Heating to 30°C will help it to dissolve.

- 4 Make up to the 500 ml mark with the water, and mix well.
- 5 Label the bottle and store in a cool dark place. The stain is stable for several months.

*For use:* Filter some of the stain into a dropper bottle or other suitable stain dispensing container.

**Bacitracin discs, 0.05 units No. 15**

These are best purchased as standardized tested discs from Oxoid Ltd (see Appendix II) or other manufacturers of *diagnostic* bacitracin discs.\*

\*Oxoid reference for bacitracin 0.05 unit bacitracin discs is DD 0002. The discs are supplied in vials containing 50 discs. They have a shelf-life of 8 months when stored at 2–8°C.

**Blood agar and chocolate agar No. 16**

**BLOOD AGAR**

*To make about 35 blood agar plates:*

Nutritious agar\* . . . . . 500 ml  
 Sterile defibrinated blood\*\* . . . . . 25 ml

\*Dehydrated agar products from which to prepare blood agar include: *Blood agar base* (Oxoid product CM 0055), *Columbia agar*, or *Tryptone soya agar* (available from most suppliers of culture media).

\*\*For most pathogens, haemolysis-free defibrinated horse, sheep, goat, or rabbit blood can be used. Sheep blood however, may contain inhibitors to *H. influenzae*. Human blood, particularly expired citrated donor blood, should not be used because this may contain substances inhibitory to the growth of some pathogens. Citrate inhibits the growth of *beta*-haemolytic streptococci. Human blood may also contain infectious agents and antibiotics.

*Note:* Before preparing a batch of blood agar plates, a few plates should be prepared first to make sure the blood is sterile.

- 1 Prepare the agar medium as instructed by the manufacturer. Sterilize by autoclaving at 121°C for 15 minutes. Transfer to a 50°C water bath.
- 2 When the agar has cooled to 50°C, add aseptically the sterile blood and mix gently but well. Avoid forming air bubbles.  
*Important:* The blood must be allowed to warm to room temperature before being added to the molten agar.
- 3 Dispense aseptically in 15 ml amounts in sterile petri dishes as described in subunit 7.4.
- 4 Date the medium and give it a batch number.
- 5 Store the plates at 2–8°C, preferably in sealed plastic bags to prevent loss of moisture.

**Shelf-life:** Up to 4 weeks or longer providing there is no change in the appearance of the medium to suggest contamination, haemolysis, or deterioration.

#### Use of layered blood agar plates

This reduces the amount of blood needed and is also preferred by some workers because the thinner layer of blood enables haemolytic reactions to be seen more clearly.

Layered blood agar plates are prepared by pouring about 8 ml of the agar into each plate and when this has gelled, adding 8 ml of blood agar.

**pH of medium:** Depending on the agar base used, the pH should be within the range pH 7.2–7.6 at room temperature.

**Performance:** Inoculate plates with 5 hour broth cultures of *S. pyogenes* and *S. pneumoniae*. Inoculate also a plate with *H. influenzae* and streak with *S. aureus* as described in subunit 7.18.24.

Incubate the plates in a carbon dioxide enriched atmosphere at 35–37°C overnight. Check for the growth characteristics of each species, e.g. haemolytic reactions of *S. pyogenes* and *S. pneumoniae* and the satellitism of *H. influenzae*. Note also the size of the colonies and degree of growth. Compare with the results of previous performance tests.

#### CHOCOLATE (HEATED BLOOD) AGAR

When blood agar is heated, the red cells are lysed and the medium becomes brown in colour. It is referred to as chocolate agar and supplies the factors required for the growth of *H. influenzae*. It is also used to culture nutritionally demanding pathogens such as *N. meningitidis* and *S. pneumoniae*.

- 1 Prepare as described for blood agar except after adding the blood, heat the medium in a 70°C water bath until it becomes brown in colour. This takes about 10–15 minutes during which time the medium should be mixed gently several times.
- 2 Allow the medium to cool to about 45°C, remix and dispense in sterile petri dishes as described for blood agar.

**Important:** Care must be taken not to over-heat or prolong the heating of the medium because this will cause it to become granular and unfit for use.

- 3 Date the medium and give it a batch number. Store the plates as described for blood agar.

**Performance:** Test the medium by inoculating it with *H. influenzae*. After overnight incubation in a candle jar at 35–37°C, record the growth and compare with the results of previous performance tests.

---

#### Neomycin Blood Agar

This is used as a selective medium for obligate anaerobes. At a concentration of 70 µg/ml, neomycin sulphate inhibits facultative anaerobic Gram negative rods.

**Note:** At concentrations over 10 µg/ml, neomycin sulphate may inhibit the growth of *P. melaninogenicus*. Anaerobic Gram positive cocci may not grow on neomycin (or kanamycin) blood agar.

- 1 Prepare a stock solution containing 70 000 µg/ml neomycin by dissolving 0.5 g neomycin sulphate (containing 0.35 g neomycin base) in 5 ml of sterile water. From this, prepare a working solution of 17 500 µg/ml by mixing 2 ml of stock solution with 6 ml of sterile water.
- 2 Add 1 ml of working neomycin sulphate solution to 250 ml of blood agar to give a concentration of 70 µg/ml. Mix well and pour in sterile petri dishes as described for blood agar. Label the plates 'N'.
- 3 Date the medium and give it a batch number. Store the plates as described for blood agar.

**Performance:** Test the medium by inoculating half a plate with a 5 hour cooked meat broth culture of *B. fragilis* and the other half with a 5 hour culture containing *B. fragilis* and *Proteus*. After 48 hours anaerobic incubation at 35–37°C, record the selectivity of the medium and compare with the results of previous performance tests.

#### Kanamycin Blood Agar

This medium may be used as an alternative to neomycin blood agar. At a concentration of 75 µg/ml, kanamycin is selective for obligate anaerobes including *P. melaninogenicus*.

- 1 Prepare a 15 g/l kanamycin solution by dissolving 1.5 g kanamycin sulphate in 100 ml of sterile water. Add 1 ml of this solution to every 200 ml of blood agar. Mix well and pour in sterile petri dishes as described for blood agar. Label the plates 'K'.
- 2 Date the medium and give it a batch number. Store the plates as described for blood agar.

**Crystal Violet Blood Agar**

Blood agar can be made selective for *S. pyogenes* by the addition of the dye crystal violet. At a concentration of 1 in 500 000, crystal violet inhibits the growth of *S. aureus* and reduces the growth of commensals in throat specimens.

- 1 Add 1 ml of 0.02% w/v aqueous solution of crystal violet to every 100 ml of sterile blood agar. Mix well and dispense in sterile petri dishes. Label the plates 'CV'.
- 2 Date the medium and give it a batch number. Store the plates as described for blood agar.

*Performance:* Test the medium by inoculating half a plate with a 5 hour broth culture of *S. pyogenes* and the other half with a 5 hour culture containing *S. pyogenes* and *S. aureus*. After overnight incubation in a candle jar at 35–37°C, record the selectivity of the medium and compare with the results of previous performance tests.

**Brilliant cresyl blue 10 g/l (1 g% w/v) No. 17**  
*To make about 100 ml:*

Brilliant cresyl blue G	1.0 g
Sodium citrate	0.6 g
Sodium chloride	0.7 g
Distilled water	100 ml

- 1 Weigh the sodium citrate and sodium chloride and dissolve in the water.
- 2 Add the brilliant cresyl blue and mix until it is completely dissolved.
- 3 Label the container. Store at 2–8°C.
- 4 Filter before use.

**Buffer indicator solution, pH 7.2 No. 18**  
*To make 100 ml:*

<i>di</i> -Potassium hydrogen phosphate, . . . . .	0.04 g
anhydrous (K <sub>2</sub> HPO <sub>4</sub> )	
Potassium dihydrogen phosphate . . . . .	0.01 g
(KH <sub>2</sub> PO <sub>4</sub> )	
Potassium chloride. . . . .	0.80 g
Phenol red, 10 g/l (1 % w/v)* . . . . .	0.2 ml
Distilled water . . . . .	to 100 ml

\*Prepare by dissolving 0.2 g of phenol red in 20 ml of distilled water.

- 1 Weigh accurately the phosphate chemicals and potassium chloride. Transfer these to a 100 ml volumetric flask.
- 2 Half fill the flask with distilled water. Mix well

to dissolve the chemicals.

- 3 Add the phenol red indicator solution, and mix.
- 4 Make up to the 100 ml mark with distilled water, and mix well.
- 5 Using a pH meter or narrow range pH papers, check that the pH of the buffer is within the range 7.1–7.3.
- 6 Transfer the solution to a storage bottle and label. When stored at 2–8°C, the buffer is stable for several months.

**Buffered carbohydrate indicator solutions No. 19**

*To make 10 ml of each solution:*

Carbohydrate (weigh separately):

glucose, sucrose, maltose . . . . .	2.0 g
soluble starch . . . . .	0.5 g
Buffer indicator solution* . . . . .	to 10 ml

\*See reagent No. 18.

- 1 Weigh accurately each carbohydrate and transfer to separate screw-cap bottles pre-marked to hold 10 ml. Label each of the four bottles.
- 2 Add buffer indicator solution to the 10 ml mark of each bottle, and mix to dissolve the carbohydrates.
- 3 Dispense each carbohydrate solution in 1 ml amounts in small containers. Label, and store at –20°C. When frozen, the solutions remain stable for several months. When thawed the solutions are stable for about 1 month at 2–8°C.

**Buffered water pH 6.4, pH 6.8, pH 7.0, pH 7.2, pH 8.0 No. 20**

These reagents can be conveniently prepared from stock phosphate buffer solutions.

*Stock phosphate solution A*

Sodium dihydrogen phosphate, . . . . .	27.6 g
1-hydrate (NaH <sub>2</sub> PO <sub>4</sub> ·H <sub>2</sub> O)	
Distilled water . . . . .	to 1 litre

- 1 Accurately weigh the chemical and transfer it to a 1 litre volumetric flask.
- 2 Half fill the flask with water, and mix to dissolve the chemical. Make up to the 1 litre mark with distilled water, and mix well. Transfer to a leak-proof bottle.
- 3 Label the bottle 'Stock phosphate solution A'.

Store in a cool place or preferably at 2–8°C. The solution is stable for several months.

#### Stock phosphate solution B

*di*-Sodium hydrogen phosphate, . . . . . 28.39 g anhydrous (Na<sub>2</sub>HPO<sub>4</sub>)  
Distilled water . . . . . to 1 litre

Prepare as described above for solution A. Label the bottle 'Stock phosphate solution B'. Store in a cool place or preferably at 2–8°C. The solution is stable for several months.

Prepare 1 litre pH 6.4, pH 6.8, pH 7.0, pH 7.2, pH 8.0 as follows:

Measure the stock solutions and mix with the distilled water. Check the pH using narrow range pH papers or a pH meter. Store in a leak proof container in a cool place.

pH	A Stock ml	B Stock ml	Distilled Water ml
6.4	367.5	132.5	500
6.8	255	245	500
7.0	195	305	500
7.2	140	360	500
8.0	26.5	473.5	500

#### Alternative preparation of buffered water reagents using Na<sub>2</sub>HPO<sub>4</sub> and KH<sub>2</sub>PO<sub>4</sub> chemicals

- To make 1 litre pH 6.8 buffered water:  
*di*-Sodium hydrogen phosphate . . . . . 0.47 g anhydrous (Na<sub>2</sub>HPO<sub>4</sub>)  
Potassium *di*-hydrogen phosphate . . . . . 0.46 g anhydrous (KH<sub>2</sub>PO<sub>4</sub>)  
Distilled water . . . . . to 1 litre  
Weigh the chemicals and dissolve completely in the water. Check the pH. Store in a leak proof labelled container in a cool place.
- To make 1 litre pH 7.0 buffered water:  
*di*-Sodium hydrogen phosphate . . . . . 0.58 g anhydrous (Na<sub>2</sub>HPO<sub>4</sub>)  
Potassium *di*-hydrogen phosphate . . . . . 0.35 g anhydrous (KH<sub>2</sub>PO<sub>4</sub>)  
Distilled water . . . . . to 1 litre  
Weigh the chemicals and dissolve completely

in the water. Check the pH. Store in a leak proof labelled container in a cool place.

#### Carbol fuchsin

No. 21

To make about 1115 ml:

Basic fuchsin . . . . . 10 g  
Ethanol or methanol, absolute\* . . . . . 100 ml  
Phenol . . . . . 50 g  
Distilled water . . . . . 1 litre

\* Technical grade is adequate.

- 1 Weigh the basic fuchsin on a piece of clean paper (preweighed), and transfer the powder to a container of at least 1.5 litre capacity.
- 2 Measure the ethanol (ethyl alcohol) or methanol (methyl alcohol), and add to the bottle. Mix at intervals until the basic fuchsin is completely dissolved.  
**Caution:** Methanol and ethanol are highly flammable, therefore use these chemicals well away from an open flame.
- 3 With great care, weigh the phenol in a beaker. Measure the water, and add some of it to the beaker to dissolve the phenol. Transfer to the bottle of stain, and mix well.  
**Caution:** Phenol is a highly corrosive, toxic, and hygroscopic chemical, therefore handle it with *great care*. To avoid spilling phenol on the balance pan, remove the beaker when adding or subtracting the chemical.
- 4 Add the remainder of the water, and mix well.
- 5 Label, and store at room temperature. The stain is stable indefinitely.

*For use:* Filter a small amount of the stain into a dropper bottle or other suitable stain dispensing container.

#### Cary-Blair transport medium

No. 22

This medium is best prepared from ready to use dehydrated powder available from most suppliers of culture media.

*Contents:* Sodium thioglycollate, *di*-sodium hydrogen phosphate, sodium chloride, agar, calcium chloride.

The medium is usually used at a concentration of 1.3 g in every 100 ml distilled water (concentration may vary depending on manufacturer).

- 1 Prepare as instructed by the manufacturer. Dispense the medium in 7 ml amounts in screw-cap bottles of 9 ml capacity (large size Bijou bottles).

- 2 Sterilize by steaming (with caps loosened) for 15 minutes. When cool, tighten the bottle caps. Label the bottles.
- 3 Date the medium and give it a batch number. Record the expiry date (6 months from preparation) on each bottle.
- 4 Store in a cool dark place with the bottle tops screwed tightly.

*Shelf-life:* Up to about 18 months providing there is no change in the appearance of the medium to suggest contamination or alteration of pH.

*pH of medium:* This should be within the range pH 8.3–8.5 at room temperature.

**Inoculation**

Immerse a swab of the faecal specimen in the medium, cutting off the swab stick to allow the bottle top to be replaced tightly. Protect the swab from direct light and excessive heat.

*Salmonella, Shigella, Vibrio, and Y. enterocolitica* survive well in Cary-Blair medium for at least 48 hours (several days for *Salmonella, Shigella, Vibrio* species) and *Campylobacter* species for up to 6 hours. It is also a good transport medium for *Y. pestis*.

**Cetylpyridinium chloride-sodium chloride (CPC–NaCl) solution No. 23**

*To make 1 litre:*

- N-Cetylpyridinium chloride. . . . . 5 g
- Sodium chloride . . . . . 10 g
- Distilled water . . . . . to 1 litre

- 1 Weigh the cetylpyridinium chloride\* and sodium chloride. Transfer to a bottle pre-marked to hold 1 litre.

\*Available from Merck/BDH (see Appendix 11).

- 2 Add about 200 ml of distilled water, and mix to dissolve the chemicals.
- 3 Make up to the 1 litre mark with distilled water, and mix well.
- 4 Label the bottle and store it in a cool place. The reagent is stable for several months.

**Charcoal cephalalexin blood agar (CCBA) No. 24**

*To prepare 6 plates:*

- Charcoal agar (Oxoid). . . . . 100 ml
- Sterile sheep, horse, or goat blood. . . . . 10 ml
- Cephalalexin, to give 40 mg/l\* of medium . . 0.4 ml

\*This is available in lyophilized form from Oxoid Ltd as *Bordetella Selective Supplement*, code SR 0082. Each vial is reconstituted with 2 ml of sterile distilled water. Unopened vials have a shelf-life of 2 years. The reconstituted solution can be kept for 3 months when stored frozen at –20°C.

- 1 Prepare and sterilize the charcoal agar as instructed by the manufacturer. Transfer to a 50°C water bath.
- 2 When the medium has cooled to 50°C, add aseptically the sterile blood (pre-warmed to room temperature), and mix gently.
- 3 Add the antibiotic solution and mix gently but well. Avoid forming air bubbles.
- 4 Dispense immediately in about 18 ml amounts in sterile petri dishes. Date the medium and give it a batch number.

- 5 Store the plates at 2–8°C in sealed plastic bags to prevent loss of moisture.

*Shelf-life:* Up to 10 days providing there is no change in the appearance of the medium to suggest contamination or deterioration.

*pH of medium:* This should be within the range pH 7.2–7.6 at room temperature.

**Inoculation**

Dry the surface of the medium for the minimum length of time. Use the pernasal swab to inoculate the entire plate (see subunit 7.18.26).

**Bordetella Transport Medium**

The CCBA medium as described above can also be used as a *Bordetella* transport and enrichment medium by preparing the charcoal agar in half strength, i.e. use half the amount of charcoal agar powder to the volume of water required. Add the *same* amount of blood and cephalalexin to 100 ml half strength charcoal agar as given in the plate medium formula.

Dispense the transport medium in sterile 5 ml capacity Bijou bottles (do not fill completely). Label the bottles. Date the medium and give it a batch number. Record the expiry date (8 weeks from preparation) on each bottle. Store the bottles at 2–8°C with tops tightly screwed.

**Christensens urea broth No. 25**

*To prepare about 33 bottles:*

- Urea broth base (Oxoid Ltd, code CM 0071). 95 ml
- Sterile urea solution, 40% w/v\* . . . . . 5 ml

\*Available from Oxoid Ltd, code SR 0020K, in 5 ml ampoules (sterile) packed in boxes of ten. The solution has a shelf-life of 2 years when stored at 2–8°C.

- 1 Prepare and sterilize the urea broth base as instructed by the manufacturer. Transfer to a 50–55°C water bath.

- When the medium has cooled to 50–55 °C, add aseptically the sterile urea solution, and mix well.
- Dispense aseptically in 3 ml amounts in sterile Bijou bottles or screw-cap tubes. Date the medium and give it a batch number.
- Store in a cool dark place or at 2–8 °C.

*Shelf-life:* Up to 6 months providing there is no change in the volume or appearance of the medium to suggest contamination or alteration of pH.

*pH of medium:* This should be within the range pH 6.6–7.0 at room temperature.

*Performance:* Test the medium with bacterial species of known positive and negative urease reactions.

### **Columbia diphasic medium** **No. 26**

Columbia diphasic medium (Castañeda form) consists of Columbia broth and a slope of Columbia agar (see subunit 7.14).

#### *Columbia agar\**

\*Available from Oxoid Ltd, code CM 0331, and other major suppliers of culture media.

- Prepare the agar medium as instructed by the manufacturer. Dispense in 20–25 ml amounts in bottles of the medical (200 ml) flat type fitted with screw-caps that have a central hole and rubber liner.
- Sterilize by autoclaving (with caps loosened) at 121 °C for 15 minutes. Allow the medium to cool with the bottles in a horizontal position to give an agar slope along one side (see subunit 7.4).

#### *Columbia broth\**

\*Available from Becton-Dickinson-Difco, code 294420, and other major suppliers of culture media.

- Prepare the broth medium as instructed by the manufacturer. Prior to sterilizing, add 0.5 g of *Liquoid* and 0.05 g of *p*-aminobenzoic acid and mix well to dissolve.

*Note:* *Liquoid* (sodium polyanethyl sulphate)\* as a blood neutralizer and anticoagulant, and 0.05 g of *p*-aminobenzoic acid to neutralize the effects of sulphonamides.

\*Available from Roche Products Ltd (see Appendix II). When unavailable, add 5 g of sodium citrate to every 1 litre of the broth.

- Sterilize the broth by autoclaving at 121 °C for 15 minutes. Allow to cool to about 50 °C. Dispense aseptically 25 ml of the sterile broth in each bottle containing an agar slope.
- Cover each bottle top with a foil cap, *Viscap*, or other protective covering (previously soaked in 70% v/v ethanol).
- Label the bottles. Date the medium and give it a batch number. Store the bottles in an upright position in a dark cool place.

*Shelf-life:* Up to 1 year or more providing there is no change in the volume or appearance of the medium to suggest contamination or deterioration.

*pH of medium:* The pH of the agar and broth media should be within the range pH 7.3–7.4 room temperature.

#### *Inoculation*

Inoculate the medium as described in subunit 7.14. An aseptic technique is *essential*. Written inoculation instructions should be issued with each bottle of medium. As soon as possible after the medium has been inoculated, it should be incubated at 35–37 °C.

### **Cooked meat medium** **No. 27**

The medium is best prepared from ready to use dehydrated granules available from most suppliers of culture media.

*Contents:* Heart muscle, peptone, *Lab-Lemco* powder, sodium chloride, glucose.

- Using a small tube or scoop pre-marked to hold 1 g of the granules, dispense the medium in 1 g amounts in screw-cap bottles or tubes.
- Add 10 ml of distilled water, mix, and allow to soak for 5 minutes.
- Sterilize the medium by autoclaving (with caps loosened) at 121 °C for 15 minutes. When cool, tighten the bottle caps. Date the medium and give it a batch number.
- Store the medium in a cool dark place, making sure the bottle tops are tightly screwed.

*Shelf-life:* Up to two years providing there is no change in the volume or appearance of the medium to suggest contamination.

*pH of medium:* This should be within the range pH 7.0–7.4 at room temperature.

*Inoculation*

Depending on the specimen, cooked meat medium is inoculated using a swab, Pasteur pipette, or wire loop. If using a swab this should be inserted to the bottom of the container.

For the culture of strict anaerobes, the medium is best used fresh or after being placed (with bottle top loosened) in a container of boiling water for 10–15 minutes to drive off any dissolved oxygen. Allow the medium to cool to room temperature before inoculating it.

**Crystal violet blood agar**, see No. 16.

**Crystal violet Gram stain No. 28**

*To make 1 litre:*

- Crystal violet . . . . . 20 g
- Ammonium oxalate . . . . . 9 g
- Ethanol or methanol, absolute . . . . . 95 ml
- Distilled water . . . . . to 1 litre

- 1 Weigh the crystal violet on a piece of clean paper (preweighed). Transfer to a brown bottle premarked to hold 1 litre.
- 2 Add the absolute ethanol or methanol (technical grade is suitable) and mix until the dye is completely dissolved.

**Caution:** Ethanol and methanol are highly flammable, therefore use these chemicals well away from an open flame.

- 3 Weigh the ammonium oxalate and dissolve in about 200 ml of distilled water. Add to the stain. Make up to the 1 litre mark with distilled water, and mix well.

**Caution:** Ammonium oxalate is a toxic chemical, therefore handle it with care.

- 4 Label the bottle, and store it at room temperature. The stain is stable for several months.

*For use:* Filter a small amount of the stain into a dropper bottle or other stain dispensing container.

**Crystalline penicillin bromocresol purple solution No. 29**

*To make about 40 ml:*

- Benzylpenicillin, potassium salt\* . . . . . 2 g
- Phosphate buffer, pH 8 (Reagent No. 20) . 40 ml
- Bromocresol purple, 2 g/l (0.2% w/v)\*\* . . 0.08 ml

\*Available from Merck/BDH (see Appendix II).

\*\*Prepare by dissolving 0.1 g of bromocresol purple in 50 ml of distilled water. Store in a brown bottle away from direct light.

- 1 Weigh the benzylpenicillin and dissolve in the phosphate buffer, pH 8.
- 2 Add the bromocresol purple indicator solution, and mix well.
- 3 Dispense in 5 ml amounts in small containers, stopper, and label. Store frozen at –20°C. The frozen reagent can be kept for up to 3 months. When thawed, the reagent is stable for 1 month at 2–8°C.

**Cystine lactose electrolyte deficient (CLED medium) No. 30**

This medium is best prepared from ready to use dehydrated powder, available from most suppliers of culture media.

*Contents:* Peptone, *Lab-Lemco* powder, tryptone, lactose, L-cystine, bromothymol blue, agar.

The medium is usually used at a concentration of 18.1 g in every 500 ml distilled water (concentration may vary depending on manufacturer).

- 1 Prepare as instructed by the manufacturer. Sterilize by autoclaving at 121°C for 15 minutes.
- 2 Mix well before pouring (avoid air bubbles forming). Dispense aseptically in 15 ml amounts in sterile petri dishes as described in subunit 7.4.
- 3 Date the medium and give it a batch number.
- 4 Store the plates at 2–8°C, preferably sealed in plastic bags to prevent loss of moisture.

**Shelf-life:** Up to 4 weeks or longer provided there is no change in the appearance of the medium to suggest contamination or a change in pH.

*pH of medium:* This should be within the range pH 7.3–7.5 at room temperature.

**Deoxycholate citrate agar (DCA) No. 31**

This medium is best prepared from ready to use dehydrated powder, available from most suppliers of culture media.

*Contents:* Peptone, *Lab-Lemco* powder, lactose, sodium citrate, sodium thiosulphate, ferric citrate, sodium deoxycholate, neutral red, agar.

The medium is usually used at a concentration of 5.2 g in every 100 ml distilled water (concentration may vary depending on manufacturer).

For the isolation of *Y. enterocolitica*, an extra 2 g sodium deoxycholate should be added to every 100 ml of medium.

- 1 Prepare the medium as instructed by the manufacturer. Heat with great care and do *not* boil or autoclave.
- 2 As soon as the medium has cooled to 50–55°C, mix well and dispense aseptically in sterile petri dishes as described in subunit 7.4.
- 3 Label the plates 'DCA'. Date the medium and give it a batch number. Store the plates at 2–8°C, preferably in sealed plastic bags to prevent loss of moisture.

*Shelf-life:* Up to 6 weeks providing there is no change in the appearance of the medium to suggest contamination or an alteration of pH.

*pH of medium:* This should be within the range pH 7.1–7.5 at room temperature.

#### **Dimethylsulphoxide KOH reagent** **No. 32**

*To make about 120 ml:*

Potassium hydroxide (KOH) . . . . . 20.0 g  
Dimethylsulphoxide (DMSO) . . . . . 40 ml  
Distilled water . . . . . 60 ml

- 1 Mix the DMSO with the water.
- 2 Weigh the KOH and add to the DMSO solution.

**Caution:** KOH is a highly corrosive and deliquescent chemical, therefore handle it with great care and make sure the stock bottle of chemical is tightly stoppered after use.

- 3 Mix until the KOH is completely dissolved. Label the bottle and mark it *Corrosive*. Store at room temperature out of direct sunlight.

#### **DNase agar** **No. 33**

This medium is best prepared from ready to use dehydrated powder, available from most suppliers of culture media.

*Contents:* Tryptose, deoxyribonucleic acid, sodium chloride, agar.

The medium is usually used at a concentration of 3.9 g in every 100 ml distilled water (concentration may vary depending on manufacturer).

- 1 Prepare and sterilize as instructed by the manufacturer.

- 2 When the medium has cooled to 50–55°C, mix well and dispense in sterile petri dishes. Date the medium and give it a batch number.
- 3 Store the plates at 2–8°C in sealed plastic bags to prevent loss of moisture.

*Shelf-life:* 3–4 weeks when stored in plastic bags providing there is no change in the appearance of the medium to suggest contamination or deterioration.

*pH of medium:* This should be within the range pH 7.1–7.5 at room temperature.

*Performance:* Test the medium each time it is used by inoculating on the same plate as the test organisms, staphylococcal species of known positive and negative DNA-ase activity as explained in subunit 7.5.5.

#### **Dorset egg medium** **No. 34**

*To make about 33 slopes:*

Nutrient broth . . . . . 20 ml  
Whole *fresh* eggs . . . . . 80 ml

- 1 Prepare and sterilize the nutrient broth as described in No. 63.
- 2 Wash the eggs by scrubbing them carefully with soap and water followed by rinsing in clean running water. Immerse the eggs in 70% v/v ethanol (alcohol) for 10 minutes.
- 3 As aseptically as possible, break the eggs into a sterile flask (premarked to hold 80 ml) which contains a few sterile beads. Mix well until the egg yolks and whites are completely homogenized.
- 4 Strain the egg mixture through sterile gauze or muslin into a sterile bottle.
- 5 When the nutrient broth has cooled to 45–50°C, add it aseptically to the egg mixture, and mix well.
- 6 Dispense aseptically the medium in 3 ml amounts in sterile Bijou bottles or screw-cap tubes.
- 7 Inspissate at 75–80°C with the bottles in a sloped position until the medium has solidified. Date the medium and give it a batch number.
- 8 Store the slopes with bottle tops tightly screwed in a cool dark place or at 2–8°C.

*Shelf-life:* Up to 2 years providing there is no change in the appearance of the medium to suggest contamination or deterioration.



*pH of medium:* This should be within the range pH 7.2–7.6 at room temperature.

**Eosin, alkaline stain** **No. 35**

*To make 56 ml:*

- Eosin, 5 g/l (0.5% w/v)\* . . . . . 10.0 ml
- Sodium carbonate, 100 g/l (10 w/v)\*\* . . . . . 0.5 ml
- Formaldehyde solution, concentrated . . . . . 0.5 ml
- Distilled water . . . . . 45.0 ml

\*Prepare by dissolving 0.5 g of eosin (water-soluble) in 100 ml distilled water.

\*\*Prepare by dissolving 1 g of sodium carbonate in 10 ml distilled water.

- 1 Mix 0.5 ml of the sodium carbonate solution with 10 ml of the eosin solution in a *brown* bottle of 60 ml capacity.

- 2 Add the water and formaldehyde solution. Mix well.

**Caution:** Concentrated formaldehyde solution is a toxic chemical with an injurious vapour, therefore handle it with care in a well ventilated room. *Do not* mouth-pipette.

- 3 Label the bottle and store it at room temperature. The stain is stable for several months.

*For use:* Transfer a small amount of the stain to a bottle with a cap into which a dropper can be inserted.

**Eosin, 5 g/l (0.5% w/v) for faecal preparations** **No. 36**

*To make about 100 ml:*

- Eosin powder . . . . . 0.5 g
- Distilled water . . . . . 100 ml

- 1 Weigh the eosin on a clean piece of paper (pre-weighed), and transfer to a *brown* bottle.

- 2 Add 100 ml distilled water and mix to dissolve the stain.

- 3 Label the bottle, and store it at room temperature. The stain is stable for several months.

*For use:* Transfer a small amount of the stain to a bottle with a cap into which a dropper can be inserted.

**Ethylenediamine tetra-acetic acid (EDTA)** **No. 37**

- di*-potassium ethylene- . . . . . 2.5 g
- diamine-tetra-acetic acid
- Distilled water . . . . . 25 ml

- 1 Weigh the chemical, and transfer it to a small glass bottle.

- 2 Measure 25 ml of water, add to the chemical, and mix to dissolve. Label the bottle.

- 3 For use, pipette 0.04 ml of the reagent into small bottles marked to hold 2.5 ml of blood.

- 4 Place the small bottles without tops, on a warm bench for the anticoagulant to dry. Protect from dust and flies.

- 5 When dry, replace the bottle tops, and store ready for use.

**Formol saline fixative** **No. 38**

*To make about 1 litre:*

- Sodium chloride, 85 g/l (8.5% w/v)\* . . . . . 900 ml (Physiological saline)
- Formaldehyde solution, concentrated . . . . . 100 ml
- Sodium carbonate, 100 g/l (10% w/v)\*\* . . . . . 3–4 drops

\*See Reagent No. 68.

\*\*Prepare by dissolving 2 grams of sodium carbonate in 20 ml distilled water.

- 1 Fill a large cylinder to the 900 ml mark with the sodium chloride solution.

- 2 Add 100 ml of the concentrated formaldehyde solution i.e. to the 1 000 ml mark.

**Caution:** Formaldehyde solution is a dangerous chemical. It is toxic when inhaled, swallowed, or when coming into contact with skin. Its vapour is irritating to the eyes and mucous membranes, therefore handle it with great care in a well ventilated room.

- 3 Transfer the solution to a screw-cap bottle. Add 3–4 drops of the sodium carbonate solution, and mix well.

- 4 Label the bottle, and mark it *Toxic* and *Harmful*. Store it at room temperature. The reagent is stable indefinitely.

**Giemsa stain** **No. 39**

*To make about 500 ml:*

- Giemsa powder . . . . . 3.8 g
- Glycerol (glycerine) . . . . . 250 ml
- Methanol (methyl alcohol) . . . . . 250 ml

- 1 Weigh the Giemsa on a piece of clean paper (preweighed), and transfer it to a *dry* brown bottle of 500 ml capacity which contains a few dry glass beads.

**Note:** *Giemsa stain will be spoilt if any water*

enters the stock solution during its preparation or storage.

- Using a dry cylinder, measure the methanol, and add to the stain. Mix well.

**Caution:** Methanol is toxic and highly flammable, therefore handle it with care well away from an open flame.

- Using the same cylinder, measure the glycerol, and add it to the stain. Mix well.
- Place the bottle of stain in a water bath at 50–60 °C, or if not available at 37 °C, for up to 2 hours to help the stain to dissolve. Mix well at intervals.
- Label the bottle, and mark it *Flammable* and *Toxic*. Store it at room temperature in the dark. When kept tightly stoppered, the stain is stable for several months. Moisture must *not* be allowed to enter the stain.

*For use:* Filter a small amount of the stain into a stain dispensing container which can be closed when not in use.

#### Glucose (dextrose) broth No. 40

This medium is best prepared from ready to use dehydrated powder, available from most suppliers of culture media.

*Contents:* Tryptose, Lab-Lemco powder, glucose, sodium chloride.

The medium is usually used at a concentration of 22.3 g in every 100 ml distilled water (concentration may vary depending on manufacturer).

- Prepare as instructed by the manufacturer. Dispense the well-mixed medium in 5 ml amounts in screw-cap Bijou bottles.
- Sterilize by autoclaving (with caps loosened) at 121 °C for 15 minutes. When cool, tighten the bottle caps. Date the medium and give it a batch number.
- Store the medium in a cool dark place.

*Shelf-life:* Up to 2 years providing there is no change in the volume or appearance of the medium to suggest contamination.

*pH of medium:* This should be within the range pH 7.0–7.4 at room temperature.

#### Glucose phosphate peptone water No. 41

*To make about 50 bottles:*

Peptone . . . . .	0.5 g
Glucose (dextrose) . . . . .	0.5 g
di-Potassium hydrogen phosphate. . . . .	0.5 g
(K <sub>2</sub> HPO <sub>4</sub> )	
Distilled water. . . . .	100 ml

- Dissolve the peptone and phosphate salt in the water by steaming. When cool, filter, and adjust the pH to 7.5.
- Add the glucose and mix well. Dispense the medium in 2 ml amounts in small screw-cap tubes or bottles.
- Sterilize by autoclaving (with caps loosened) at 115 °C for 10 minutes. When cool, tighten the container tops. Date the medium and give it a batch number.
- Store the medium in a cool dark place or at 2–8 °C.

*Shelf-life:* Up to 2 years providing there is no change in the volume or appearance of the medium to suggest contamination or alteration of pH.

*pH of medium:* This should be within the range pH 7.4–7.6 at room temperature.

#### Glycerol saline transport medium No. 42

*To make about 140 bottles:*

Sodium chloride . . . . .	4.2 g
di-Sodium hydrogen phosphate . . . . .	3.1 g
(Na <sub>2</sub> HPO <sub>4</sub> ), anhydrous	
Potassium dihydrogen phosphate . . . . .	1.0 g
(KH <sub>2</sub> PO <sub>4</sub> )	
Phenol red, 1% w/v* . . . . .	0.3 ml
Glycerol . . . . .	300 ml
Distilled water. . . . .	700 ml

\*Prepare by dissolving 0.5 g phenol red in 50 ml distilled water.

- Dissolve the dry chemicals in the water and adjust the pH to 7.2.
- Add the phenol red solution and the glycerol. Mix well. Dispense in 7 ml amounts in screw-cap bottles.
- Sterilize by autoclaving (with caps loosened) at 121 °C for 15 minutes. When cool, tighten the caps. Label the bottles. Date the medium and give it a batch number.
- Store in a cool dark place or at 2–8 °C.

*Shelf-life:* Up to 2 years providing there is no change in the volume or appearance of the medium to suggest contamination or an alteration of pH.

*pH of the medium:* This should be within the range pH 7.1–7.3 at room temperature.

*Inoculation*

Emulsify a small amount of faecal specimen (1 g or about 1 ml if a fluid specimen) in the medium. When the specimen has been collected on a swab, immerse this in the medium.

**Hydrochloric acid, 1 mol/l (IN) No. 43**

*To make 100 ml:*

Hydrochloric acid, concentrated . . . . . 8.6 ml  
Distilled water . . . . . to 100 ml

- 1 Half fill a 100 ml volumetric flask with distilled water.
- 2 Add the 8.6 ml concentrated hydrochloric acid. Make up to the 100 ml mark with distilled water, and mix well. Transfer to a screw-cap container.

**Caution:** Concentrated hydrochloric acid is corrosive, therefore handle it with care. *Do not* mouth-pipette.

- 3 Label the bottle and store it at room temperature. The reagent is stable indefinitely.

**Iodine for staining *C. trachomatis* No. 44**

*To make about 20 ml:*

Potassium iodide . . . . . 2 g  
Iodine . . . . . 1 g  
Distilled water . . . . . 20 ml

- 1 Weigh the potassium iodide, and dissolve it *completely* in the water.
- 2 Weigh the iodine, and add it to the potassium iodide solution. Mix well to dissolve.

**Caution:** Iodine is injurious to health if inhaled or allowed to come in contact with the eyes, therefore handle it with care in a well ventilated room.

- 3 Transfer to a brown bottle and store it in the dark at room temperature. The reagent is stable for several months.

**Kanamycin blood agar**, see No. 16.

**Kligler iron agar (KIA) No. 45**

This medium is best prepared from ready to use dehydrated powder, available from Oxoid Ltd, code CM0033, and other suppliers of culture media.

*Contents:* Peptone, *Lab-Lemco* powder, yeast extract, sodium chloride, lactose, glucose (dextrose), ferric citrate, sodium thiosulphate, phenol red, agar.

The medium is usually used at a concentration of 5.5 g in every 100 ml distilled water (concentration may vary depending on manufacturer).

- 1 Prepare as instructed by the manufacturer. When cooled to 50–55°C, *mix well* and dispense in 6 ml amounts in large size tubes (approx. 16 × 160 mm).
- 2 Sterilize by autoclaving (with caps loosened) at 121°C for 15 minutes.
- 3 Allow the medium to solidify in a sloped position to give a butt 25–30 mm deep and a slope 20–25 mm long (the butt should be longer than the slope). Date the medium and give it a batch number.
- 4 Store in a cool dark place or at 2–8°C.

*Shelf-life:* About 3 weeks or longer providing the tube caps are tightly screwed and there is no change in the appearance of the medium to suggest contamination, deterioration, or an alteration of pH.

*pH of medium:* This should be within the range pH 7.2–7.6 at room temperature.

*Performance:* Test the medium as described in chart 7.7 in subunit 7.4. KIA reactions of different organisms are summarized in subunit 7.18.14.

*Inoculation*

Use a straight wire to inoculate KIA medium, first stabbing the butt and then streaking the slope in a zig-zag pattern as shown in subunit 7.4. After inoculation, make sure the tube tops are left loose.

**KIA reactions**

KIA reactions are based on the fermentation of lactose and glucose (dextrose) and the production of hydrogen sulphide.

- A yellow butt (acid production) and red-pink slope indicate the fermentation of glucose only. The slope is pink-red due to a reversion of the acid reaction under aerobic conditions. This reaction is seen with *Salmonella* and *Shigella* species and other enteric pathogens (see subunit 7.18.14).
- Cracks and bubbles in the medium indicate gas production from glucose fermentation. Gas is produced by *S. Paratyphi* and some faecal commensals.

- A yellow slope and a yellow butt indicate the fermentation of lactose and possibly glucose. This occurs with *E. coli* and other enterobacteria (see subunit 7.18.14).
- A red-pink slope and butt indicate no fermentation of glucose or lactose. This is seen with most strains of *P. aeruginosa*.
- Blackening along the stab line or throughout the medium indicates hydrogen sulphide (H<sub>2</sub>S) production, e.g. *S. Typhi* produces a small amount of blackening whereas *S. Typhimurium* causes extensive blackening.

**Lactophenol cotton blue****No. 46***To make about 45 ml:*

Phenol . . . . .	10.00 g
Cotton blue (methyl blue), water soluble*. . . . .	0.04 g
Lactic acid . . . . .	10 ml
Glycerol . . . . .	20 ml
Distilled water . . . . .	10 ml

\*Available from Merck-BDH Chemicals as methyl blue, order No. 1163160050.

- 1 Weigh the methyl blue and dissolve in the water. Warming the water will help the dye to dissolve more quickly.
- 2 Weigh the phenol in a beaker (preweighed), and add the stain solution. Stir to dissolve the phenol. Transfer to a brown bottle.

**Caution:** Phenol is a highly corrosive, toxic, hygroscopic chemical, therefore handle it with great care. To avoid damaging the balance pan, always remove the beaker when adding or subtracting the corrosive chemical. Make sure the stock bottle of phenol is tightly stoppered after use.

- 3 Add the lactic acid and glycerol, and mix well.
- 4 Label the bottle, and mark it *Corrosive*. Store in a cool dark place. The stain is stable for several months.

*Note:* Can also be bought as a ready-made solution from Merck/BDH, lactophenol blue, code 1137410100 for 100 ml.

**Lactose egg yolk milk agar****No. 47***To make 7 plates:*

Nutrient agar . . . . .	100 ml
Sterile egg yolk suspension* . . . . .	4 ml
Sterile skimmed milk** . . . . .	30 ml
Neutral red, 1% w/v . . . . .	0.35 ml
Lactose . . . . .	1.2 g

\*Prepare by mixing 2 ml of sterile physiological saline with 2 ml of egg yolk (Wash the eggs first, immerse in 70% v/v ethanol for 10 minutes, and then separate the yolks from the whites as aseptically as possible).

\*\*Reconstitute the skimmed milk powder in sterile water and bring to the boil. Allow to cool before adding to the medium.

*Note:* The medium can be made selective for *Clostridium* species by the addition of 250 µg/ml of neomycin sulphate.

- 1 Prepare the nutrient agar as described in No. 63.
- 2 Prior to sterilizing the nutrient agar, allow it to cool to 50–55 °C and then add the lactose and neutral red. Mix well. Sterilize by autoclaving at 121 °C for 15 minutes.
- 3 When the medium has cooled to 50–55 °C, add aseptically the sterile egg yolk suspension and sterile skimmed milk. Mix well being careful to avoid air bubbles forming.
- 4 Dispense immediately in sterile petri dishes. Date the medium and give it a batch number.
- 5 Store at 2–8 °C preferably in sealed plastic bags to prevent loss of moisture.

*Shelf-life:* Up to 3 weeks providing there is no change in the appearance of the medium to suggest contamination, deterioration, or alteration of pH.

*pH of medium:* This should be within the range pH 7.0–7.4 at room temperature.

*Performance:* Test as described for the control of a differential medium using appropriate *Clostridium* species to show the lecithinase, lactose, and lipase reactions (see subunit 7.18.9).

**Leishman stain****No. 48***To make about 400 ml:*

Leishman stain powder* . . . . .	0.6 g
Methanol (methyl alcohol)** . . . . .	400 ml

\*Purchase from a reliable source, e.g. Merck/BDH.

\*\*The methanol *must* be water-free.

- 1 Weigh the Leishman powder and transfer it to a completely *dry* brown bottle. Add a few dry glass beads (to assist in dissolving the dye).
- 2 Using a *dry* cylinder, measure the methanol and add this to the stain. Mix well at intervals until the dye is completely dissolved. Warming the solution in a 37 °C water bath will help the dye to dissolve.

**Caution:** Methanol is toxic and highly flammable, therefore handle it with care well away from an open flame.

- 3 Label the bottle and mark it *Flammable* and *Toxic*. Store it at room temperature in the dark. When kept tightly stoppered, the stain is stable for several weeks. Moisture *must not* be allowed to enter the stain.

*For use:* Filter 50–100 ml of the stain into a stain dispensing container which can be closed when not in use.

**Levinthal agar** **No. 49**  
*To make 5 plates:*

Sterile nutrient agar . . . . . 100 ml  
 Sterile whole blood . . . . . 5 ml  
 (preferably horse blood)

- 1 Prepare and sterilize the nutrient agar as described in No. 63.
- 2 Add the blood and mix. Heat in a container of boiling water until the blood is denatured. Allow the sediment to settle.
- 3 Aseptically dispense the clear supernatant fluid in sterile petri dishes. Date the medium and give it a batch number.
- 4 Store the plates at 2–8 °C, preferably in sealed plastic bags to prevent loss of moisture.

*Shelf-life:* Up to 10 days or longer providing there is no change in the appearance of the medium to suggest contamination or deterioration.

**Litmus milk medium** **No. 50**  
*To make about 20 ml of medium:*

Skimmed milk powder . . . . . 2 g  
 Distilled water . . . . . 20 ml  
 Litmus (indicator) . . . . . Small amount\*

\*Sufficient to give a blue-mauve colour to the milk.

- 1 Dissolve the milk in the water, and add the litmus. Sterilize by autoclaving at 110 °C for 10 minutes.

*Note:* The medium will appear colourless when hot, but will become blue-mauve again after it has cooled.

- 2 Dispense aseptically as follows:  
*Litmus milk decolorization test*  
 Dispense in 0.5 ml amounts in sterile 13 × 100 mm tubes.  
*Litmus milk fermentation test*  
 Dispense in 5 ml amounts in sterile screw-cap bottles or tubes.
- 3 Date the medium and give it a batch number. Store in a cool dark place or at 2–8 °C.

*Shelf-life:* Up to 2 years providing there is no change in the volume or appearance of the medium to suggest deterioration or contamination.

*Inoculation*  
 For the decolorization test, inoculate the medium as described in subunit 7.5.7. When used to demonstrate the ‘stormy clot’ reaction, add a flame sterilized iron nail or small strip to the medium to provide anaerobic conditions.

**Loeffler (alkaline) methylene blue** **No. 51**  
*To make about 130 ml:*

Methylene blue\* . . . . . approx. 0.5 g  
 Ethanol (ethyl alcohol), absolute . . . . . 30.0 ml  
 Potassium hydroxide, 200 g/l\*\* . . . . . 0.1 ml  
 Distilled water . . . . . 100 ml

\*Available from Merck-BDH, Order No. 34048 4B (25 g).  
 \*\*See Reagent No. 69.

- 1 Weigh the methylene blue on a piece of clean paper (preweighed). Dissolve the stain in about 30 ml of the water.  
 If required, add more methylene blue to make a saturated solution.
- 2 Transfer the stain to a brown bottle. Add the alcohol, potassium hydroxide solution, and the remainder of the water. Mix well.

**Caution:** The potassium hydroxide solution is highly corrosive, therefore handle it with care. Do not mouth-pipette. Ethanol is highly flammable, therefore use it well away from an open flame.

- 3 Label the bottle and store it in a dark place at room temperature. The stain is stable for several months.

*For use:* Transfer a small amount of the stain to a brown bottle with a cap into which a dropper can be inserted.

**Loeffler serum medium** **No. 52**  
*To make about 15 slopes:*

Sterile glucose broth . . . . . 10 ml  
 Sterile sheep, bovine, or horse serum . . . . . 30 ml

- 1 Prepare and sterilize the glucose broth as described in No. 40.
- 2 Add the sterile serum and mix. Dispense the medium in 2.5 ml amounts in sterile Bijou bottles.
- 3 Inspissate at 75 °C with the bottles in a sloped position until the medium has solidified.
- 4 Inspissate the next day for a further 1 hour. Date the medium and give it a batch number.
- 5 Store in a cool dark place or at 2–8 °C.

*Shelf-life:* Up to 2 years providing there is no change in the appearance of the medium to suggest deterioration or contamination.

*pH of medium:* This should be within the range pH 7.0–7.4 at room temperature.

*Performance:* Test the medium using a non-toxic control strain of *Corynebacterium diphtheriae*. The Albert staining technique to show volutin granules in *C. diphtheriae* is described in subunit 7.18.7.

### Lugol's iodine solution No. 53

*To make 1 litre:*

Potassium iodide..... 20 g  
Iodine ..... 10 g  
Distilled water ..... to 1 litre

- 1 Weigh the potassium iodide, and transfer to a brown bottle premarked to hold 1 litre.
- 2 Add about a quarter of the volume of water, and mix until the potassium iodide is *completely* dissolved.
- 3 Weigh the iodine, and add to the potassium iodide solution. Mix until the iodine is dissolved.

**Caution:** Iodine is injurious to health if inhaled or allowed to come in contact with the eyes, therefore handle it with care in a well ventilated room.

- 4 Make up to the 1 litre mark with distilled water, and mix well. Label the bottle, and mark it *Toxic*. Store it in a dark place at room temperature. Renew the solution if its colour fades.

*For use:* Transfer a small amount of the reagent to a brown dispensing bottle.

### MacConkey agar No. 54

This medium is best prepared from ready to use dehydrated powder, available from most suppliers of culture media.

*Contents:* Peptone, lactose, bile salts, sodium chloride, neutral red, agar.

The medium is usually used at a concentration of 5.2 g in every 100 ml distilled water.

- 1 Prepare as instructed by the manufacturer. Sterilize by autoclaving at 121 °C for 15 minutes.
- 2 When the medium has cooled to 50–55 °C, mix well and dispense aseptically in sterile

petri dishes. Date the medium and give it a batch number.

- 3 Store the plates at 2–8 °C preferably in plastic bags to prevent loss of moisture.

*Shelf-life:* Up to 4 weeks providing there is no change in the appearance of the medium to suggest contamination or an alteration of pH.

*pH of medium:* This should be within the range pH 7.2–7.6 at room temperature.

#### Some Lactose Fermenting Organisms

*E. coli*  
Enterococci  
*K. pneumoniae*

#### Some Non-Lactose Fermenting Organisms

*Salmonella* species  
*Shigella* species  
*Proteus* species  
*P. aeruginosa*  
*Y. enterocolitica*

Bacteria which do not grow on MacConkey agar include *S. pyogenes*, *S. pneumoniae*, viridans streptococci, and *Pasteurella* species.

*Note:* The preparation of sorbitol MacConkey agar is described in No. 77.

### Malachite green, 5 g/l (0.5% w/v) No. 55

*To make 1 litre:*

Malachite green..... 5 g  
Distilled water ..... to 1 litre

- 1 Weigh the malachite green on a piece of clean paper (preweighed), and transfer it to a bottle of 1 litre capacity.
- 2 Measure the water, and add about a quarter of it to the bottle. Mix until the dye is completely dissolved.
- 3 Add the remainder of the water and mix well.
- 4 Label the bottle and store it at room temperature. The stain is stable for several months.

*For use:* Transfer a small amount of the stain to a dropper bottle or other stain dispensing container.

### Mannitol salt agar No. 56

This medium is best prepared from ready to use dehydrated powder, available from most suppliers of culture media.

*Contents:* Peptone, *Lab-Lemco* powder, mannitol, sodium chloride, phenol red, agar

The medium is usually used at a concentration of 11.1 g in every 100 ml distilled water (concentration may vary depending on manufacturer).

- 1 Prepare the medium as instructed by the manufacturer. Sterilize by autoclaving at 121 °C for 15 minutes.
- 2 When the medium has cooled to 50–55 °C, mix well, and dispense it aseptically in sterile petri dishes. Date the medium and give it a batch number.
- 3 Store the plates at 2–8 °C preferably in plastic bags to prevent loss of moisture.

*Shelf-life:* Several weeks providing there is no change in the appearance of the medium to suggest contamination, deterioration, or alteration of pH.

*pH of medium:* This should be within the range pH 7.3–7.7 at room temperature.

**Methylene blue, 0.4 mmol/l (for G6PD deficiency screening test) No. 57**

*To make 1 litre:*

Methylene blue chloride\* . . . . . 0.15 g  
Distilled water . . . . . 1 litre

\*Available from Sigma Chemicals, code M-4159 (for 25 g) (see Appendix II).

- 1 Weigh the chemical and transfer to a brown bottle.
- 2 Add the water and mix until the dye is completely dissolved.
- 3 Store in the dark at room temperature. Renew if it becomes contaminated. Filter before use.

**Methylene blue for staining faecal leucocytes:**

See Loeffler methylene blue, No. 51

**Modified New York City (MNYC) medium No. 58**

GC agar base (Difco or Oxoid) . . . . . 18 g  
Distilled water. . . . . 446 ml  
Yeast extract powder\* . . . . . 0.5 g  
Sterile saponin lyzed blood\*\* . . . . . 50 ml  
Sterile glucose, 10% w/v¶ . . . . . 5 ml  
LCAT antibiotic supplement§ . . . . . 10 ml

\*Available from Oxoid Ltd (Code L0021).

\*\*Prepare by mixing 2.5 ml sterile 10% w/v saponin solution with 50 ml sterile blood (human, bovine, or horse but *not* sheep). Sterilize the saponin solution by autoclaving it at 115 °C for 10 minutes

¶Prepare by dissolving 5 grams pure glucose in 50 ml distilled water. Sterilize by autoclaving at 115 °C for 10 minutes.

§This can be obtained in sterile lyophilized form from Oxoid Ltd, code SR 0095. It is rehydrated by adding 10 ml sterile distilled water. The supplement contains lincomycin, colistin, amphotericin B, and trimethoprim lactate.

- 1 Dissolve the GC agar base and yeast extract powder in the water by heating to 100 °C (place the flask in a container of boiling water).
- 2 Sterilize by autoclaving at 121 °C for 15 minutes. Allow to cool to 50–55 °C and then add aseptically the sterile saponin lyzed blood, the glucose solution, and the antibiotic supplement. Mix well after each addition. Avoid forming air bubbles.
- 3 Dispense aseptically in sterile petri dishes. Date the medium and give it a batch number. Store the plates at 2–8 °C, sealed in plastic bags to prevent loss of moisture.

*Shelf-life:* Up to 4 weeks providing there is no change in the appearance of the medium to suggest contamination or deterioration.

*pH of medium:* The pH of the GC agar base should be within the range pH 7.0–7.4 at room temperature.

**Modified Tinsdale medium (MTM) No. 59**

*To make 5 plates:*

Proteose peptone (Oxoid or Difco) . . . . . 2.0 g  
Sodium chloride . . . . . 0.5 g  
Agar . . . . . 2.0 g  
Distilled water. . . . . 100 ml  
Sterile serum (horse, bovine, or rabbit) . . . 10 ml  
Sodium hydroxide, 0.1 mol/l (N/10) . . . . . 6 ml  
(Prepare accurately using sterile distilled water)  
L-cystine, 4 g/l (0.4 % w/v)\* . . . . . 6 ml  
Potassium tellurite, 10 g/l (1% w/v)¶ . . . . . 3 ml  
Sodium thiosulphate, 25 g/l (2.5% w/v)§ . . 1.7 ml

\*Prepare by dissolving 0.2 g L-cystine (available in 25 g amounts from Merck/BDH in 50 ml of 0.1 mol/l (N/10) hydrochloric acid. Heat to 100 °C to dissolve the chemical. *Note:* Prepare the 0.1 mol/l hydrochloric acid accurately using sterile distilled water. The solution is stable at room temperature for several months.

¶Prepare by dissolving 0.5 g potassium tellurite (Sigma code PO 677) in 50 ml sterile water. The solution is stable at room temperature for several months.

§Prepare by dissolving 0.25 g sodium thiosulphate in 10 ml sterile distilled water. Store at 2–8 °C. The solution is not stable and should be renewed weekly.

- 1 Mix the proteose peptone, sodium chloride, and agar in the water, and heat to 100 °C to dissolve the ingredients (place the flask in a container of boiling water).
- 2 Adjust the pH to 7.4. Sterilize by autoclaving at 121 °C for 15 minutes. Cool to 50–55 °C, and then add the sterile serum.\* Mix well.

\*Sterilize by filtration.

- 3 Add the remaining ingredients in the order listed in the formula, mixing well after each addition.
- 4 Dispense aseptically in 20 ml amounts in sterile petri dishes. Date the medium and give it a batch number. Store the plates at 2–8 °C in sealed plastic bags to prevent loss of moisture.  
*Shelf-life:* Up to 5 days providing there is no change in the appearance of the medium to suggest contamination or deterioration.

*pH of medium:* The reaction of the agar base should be within the range pH 7.2–7.6.

**Neomycin blood agar**, see No. 16.

**Neutral red, 1 g/l (0.1% w/v) No. 60**

*To make 1 litre:*

Neutral red . . . . . 1 g  
Distilled water . . . . . 1 litre

- 1 Weigh the neutral red on a piece of clean paper (preweighed), and transfer it to a bottle of 1 litre capacity.
- 2 Add about a quarter of the volume of water, and mix until the dye is completely dissolved.
- 3 Add the remainder of the water, and mix well.
- 4 Label the bottle and store at room temperature. The stain is stable for several months.

*For use:* Transfer a small amount of the stain to a dropper bottle or other stain dispensing container.

**New methylene blue, 10 g/l (1% w/v) No. 61**

*To make about 100 ml:*

New methylene blue\* . . . . . 1.0 g  
Sodium citrate . . . . . 0.6 g  
Sodium chloride . . . . . 0.7 g  
Distilled water . . . . . 100 ml

\*New methylene blue is chemically different to methylene blue.

- 1 Weigh the sodium citrate and sodium chloride and dissolve in the water.
- 2 Add the new methylene blue and mix until it is completely dissolved. Transfer to a brown bottle.
- 3 Label the bottle and store it at 2–8 °C.
- 4 Filter before use.

**Nitrate broth No. 62**

This medium is best prepared from ready to use dehydrated powder, available from most suppliers of culture media.

*Contents:* Beef extract, peptone, potassium nitrate.

The medium is usually used at a concentration of 0.9 g in every 100 ml distilled water (concentration may vary depending on manufacturer).

- 1 Prepare the medium as instructed by the manufacturer. Dispense in 0.5 ml amounts in small tubes.
- 2 Sterilize by autoclaving (with caps loose) at 121 °C for 15 minutes. When the medium has cooled, stopper tightly. Date the medium and give it a batch number.
- 3 Store in a cool dark place.

*Shelf-life:* For several weeks providing there is no change in volume or appearance of the medium to suggest contamination or deterioration.

*pH of medium:* This should be within the range pH 6.8–7.2 at room temperature.

**Nutrient agar and nutrient broth No. 63**

**NUTRIENT AGAR**

This medium is best prepared from ready to use dehydrated powder, available from most suppliers of culture media.

*Contents:* Peptone, *Lab-Lemco* powder, yeast extract, sodium chloride, agar.

Nutrient agar is usually used at a concentration of 2.8 g in every 100 ml distilled water (concentration may vary depending on manufacturer).

- 1 Prepare as instructed by the manufacturer. Sterilize by autoclaving at 121 °C for 15 minutes.
- 2 Dispense aseptically in the required amounts (i.e. 3 ml to make nutrient agar slopes, 5 ml to make nutrient agar deeps, or the amounts required to make blood agar or other media). Date the medium and give it a batch number.
- 3 Store in a cool dark place.

*Shelf-life:* Up to 2 years providing there is no change in the appearance of the medium to suggest contamination or deterioration.

*pH of medium:* This should be within the range pH 7.2–7.6 at room temperature.



**Inoculation of control species in agar deeps**

Stab inoculate the organism (see subunit 7.4). Incubate at 35–37°C until a small colony forms over the stab. Cover with *sterile* mineral oil. To subculture, tip the oil to one side and pick off a small quantity of growth.

**NUTRIENT BROTH**

Prepare from ready to use dehydrated nutrient broth powder. The contents of nutrient broth are the same as those for nutrient agar except that the agar is omitted. Its preparation and storage are the same as described previously for nutrient agar.

**Semisolid nutrient agar**

*To make about 20 bottles:*

- 1 Mix 0.75 g nutrient agar and 1.3 g nutrient broth in 100 ml distilled water, and heat to 100°C to dissolve the ingredients (place the flask in a boiling water bath).
- 2 Dispense the medium in 5–7 ml amounts in screw-cap bottles. Sterilize by autoclaving (with caps loosened) at 121°C for 15 minutes. When cool, tighten the bottle caps. Date the medium and give it a batch number.
- 3 Store as described previously for nutrient agar.

*Inoculation*

Use a straight wire to inoculate semisolid nutrient agar (see subunit 7.4).

**Oxidase reagent**

**No. 64**

Prepare *fresh* before use.

*To make 10 ml:*

- Tetramethyl-*p*-phenylenediamine . . . . . 0.1 g dihydrochloride\*
- Distilled water . . . . . 10 ml

\*Available from Merck/BDH, code T 3134, and other suppliers.

Dissolve the chemical in the water. The reagent is not stable. It is therefore best prepared immediately before use (see subunit 7.5.8).

*Note:* Some commercially available oxidase reagents are more stable and can be stored for several days at 2–8°C. They must be used as directed by the manufacturers. Stable oxidase reagent strips are also available (see subunit 7.5.8).

**Pancreatin mucolytic reagent**

**No. 65**

*Stock solution*

- Pancreatin\* . . . . . 5.0 g
- Physiological saline (see No. 68) . . . . . 100 ml

\*Available from Sigma Chemicals (see Appendix II).

- 1 Weigh the pancreatin and dissolve in the physiological saline.
- 2 Filter through Whatman No. 1 filter paper.
- 3 Dispense in 10 ml amounts and store frozen at –20°C. When frozen, the stock solution is stable for 1 year or more.

*Working solution*

Add 10 ml of the thawed stock pancreatin solution to 90 ml of physiological saline (Reagent No. 68) and mix well. Store at 4–6°C. The working solution is stable for several weeks. Discard if it becomes contaminated.

**Peptone water and peptone water sugars No. 66**

**PEPTONE WATER**

*To make about 65 bottles:*

- Peptone . . . . . 2 g
- Sodium chloride . . . . . 1 g
- Distilled water . . . . . 200 ml

- 1 Dissolve the peptone and salt in the water. Dispense in 3 ml amounts in screw-cap bottles (Bijou type are suitable).
- 2 Sterilize by autoclaving (with caps loosened) at 121°C for 15 minutes. When cool, tighten the bottle caps. Date the medium and give it a batch number.
- 3 Store in a cool dark place.

*Shelf-life:* Up to 2 years providing the medium shows no change in volume or appearance to suggest contamination.

*pH of medium:* This should be within the range pH 7.0–7.4.

**PEPTONE WATER SUGARS**

*To make 1 litre of peptone water with indicator:*

- Peptone . . . . . 10 g
- Sodium chloride . . . . . 5 g
- Bromothymol blue, 2 g/l (0.2% w/v)\* . . . . . 12.5 ml
- Distilled water . . . . . 1 litre

\*Prepare by dissolving 0.1 g bromothymol blue in 2.5 ml of 0.1 mol/l (N/10) sodium hydroxide. Add 47.5 ml sterile distilled water and mix well. Store in the dark.

*Note:* Bromothymol blue is used in preference to Andrade's indicator because it does not fade as quick.

- 1 Dissolve the peptone and salt in the water. Adjust the pH to 7.2–7.3. Add the indicator solution.

2 Dispense in 100 ml amounts in screw-cap bottles and sterilize by autoclaving (with caps loosened) at 121 °C for 15 minutes. When cool, tighten the bottle caps.

3 Date the medium and give it a batch number. Store in a cool *dark* place.

*Shelf-life:* The indicator medium can be stored for up to 2 years providing there is no change in the appearance of the medium to suggest contamination or alteration of pH.

**To prepare about 25 bottles of a 0.5% peptone water sugar:**

Sterile peptone water with indicator . . . . . 100 ml  
Sterile 10% w/v sugar solution\* . . . . . 5 ml

\*Prepare by dissolving 2.5 grams of the sugar required in 25 ml distilled water. Dispense in 5 ml amounts in screw-cap bottles and sterilize by filtration or steaming for 30 minutes. Alternatively, buy ampoules containing 5 ml of sterile 10% sugar solution (range usually available includes dextrose (glucose), lactose, dulcitol, maltose, mannitol, salicin, and sucrose).

- Add aseptically the sterile sugar solution to the sterile peptone water containing indicator, and mix well.
- Dispense aseptically in 4 ml amounts in sterile Bijou bottles containing an inverted Durham tube (sterilized with the bottle).
- Date the medium and give it a batch number. Use a colour code to identify the sugar medium.

**Suggested identification of peptone water sugars**

<i>Sugar</i>	<i>Colour to paint bottle cap</i>
L-Arabinose	Black and yellow
Dulcitol	Pink
Fructose	Yellow
Glucose (dextrose)	Green
Lactose	Red
Maltose	Blue and white
Mannitol (mannite)	Mauve
Mannose	Black and green
Salicin	Pink and white
Sucrose (saccharose)	Blue
Trehalose	Mauve and green
Xylose	Red and green

- Store in a cool dark place.

*Shelf-life:* Up to 6 months or longer providing there is no loss of volume or change in the appearance of the medium to indicate contamination or an alteration of pH.

*pH of medium:* This should be near pH 7.6 which will give the medium a blue colour. Bromothymol blue indicator becomes yellow at pH 6.0.

**Phosphate buffer-saponin pH 7.1** **No. 67**  
**solution**

*To make 250 ml:*

Potassium *di*-hydrogen phosphate . . . . . 33.78 g  
(KH<sub>2</sub>PO<sub>4</sub>)  
*di*-Potassium hydrogen phosphate, . . . . . 59.33 g  
anhydrous (K<sub>2</sub>HPO<sub>4</sub>)  
White saponin . . . . . 2.5 g  
Distilled water . . . . . to 250 ml

- 1 Weigh the phosphate chemicals. Dissolve these in about 150 ml of the water.
- 2 *Carefully* add the saponin, avoiding bubbles as far as possible.
- 3 Make up to 250 ml with distilled water and mix gently. Label the container and store at 2–8 °C. Renew every 3 months or if it becomes contaminated (appears turbid).

**Physiological saline, 8.5 g/l** **No. 68**  
**(0.85% w/v)**

*To make 1 litre:*

Sodium chloride . . . . . 8.5 g  
Distilled water . . . . . to 1 litre

- 1 Weigh the sodium chloride, and transfer it to a leak-proof bottle premarked to hold 1 litre.
- 2 Add distilled water to the 1 litre mark, and mix until the salt is fully dissolved.
- 3 Label the bottle, and store it at room temperature. The reagent is stable for several months. Discard if it becomes contaminated.

**Buffered saline for blood transfusion work**

This should be at pH 6.8.

*To prepare 1 litre pH 6.8 buffered saline:*

Sodium chloride . . . . . 8.5 g  
*di*-Sodium hydrogen phosphate . . . . . 0.71 g  
(Na<sub>2</sub>HPO<sub>4</sub>)  
Potassium *di*-hydrogen phosphate . . . . . 0.68 g  
(KH<sub>2</sub>PO<sub>4</sub>)  
Distilled water . . . . . to 1 litre

- 1 Weigh the chemicals and transfer them to a 1 litre volumetric flask.
- 2 About half fill the flask with distilled water and mix until the chemicals are completely dissolved.
- 3 Make up to the 1 litre mark with distilled water and mix well. Check that the pH is 6.8.
- 4 Transfer the reagent to a container, label and

store at room temperature. Discard if the reagent becomes contaminated (turbid appearance).

**Polychrome Loeffler methylene blue**, see No. 51.

**Potassium hydroxide, 200 g/l (20% w/v) No. 69**

To make 50 ml:

Potassium hydroxide (KOH) ..... 10 g  
Distilled water. .... 50 ml

1 Weigh the potassium hydroxide pellets. Transfer the chemical to a screw-cap bottle.

**Caution:** Potassium hydroxide is a highly corrosive deliquescent chemical, therefore handle it with great care and make sure the stock bottle of chemical is tightly stoppered after use.

2 Add the water, and mix until the chemical is completely dissolved.

3 Label the bottle and mark it *Corrosive*. Store it at room temperature. The reagent is stable for up to 2 years.

**Potassium permanganate, 1 g/l (0.1% w/v) No. 70**

To make 500 ml:

Potassium permanganate ..... 0.5 g  
Distilled water. .... 500 ml

1 Weigh the potassium permanganate and transfer it to a brown bottle.

2 Add about half the water, and mix to dissolve the chemical. Add the remainder of the water, and mix well.

3 Label the bottle and store it in the dark at room temperature. The reagent is stable for several months.

**Potassium permanganate, 40 g/l (4% w/v) No. 71**

To make 100 ml:

Potassium permanganate ..... 4 g  
Distilled water. .... 100 ml

Prepare as described previously for Reagent No. 70.

**Sodium bicarbonate-formalin diluting fluid No. 72**

To make about 102 ml:

Sodium bicarbonate ..... 5 g  
Formaldehyde solution, concentrated ..... 1 ml  
Distilled water. .... 100 ml

1 Weigh the sodium bicarbonate, and transfer it to a clean bottle.

2 Add the water, and mix to dissolve the bicarbonate.

3 Add the formaldehyde solution, and mix well.

**Caution:** Formaldehyde solution is a toxic chemical with a harmful and irritating vapour, therefore handle it with care in a well ventilated room. *Do not* mouth-pipette.

4 Label the bottle and mark it *Toxic*. Store it at room temperature. The reagent is stable indefinitely.

**Sodium chloride, 8.5 g/l**, see No. 68.

**Sodium citrate anticoagulant, 32 g/l No. 73**

To make 100 ml

tri-Sodium citrate, dihydrate ..... 3.2 g  
Distilled water ..... to 100 ml

1 Weigh the chemical and transfer it to a container pre-marked to hold 100 ml (or to a 100 ml volumetric flask).

2 Add about half the water and mix until the chemical is completely dissolved.

3 Add water to the 100 ml mark and mix well.

4 Label the container and store it at 2–8°C. Discard the reagent if it becomes contaminated (turbid appearance).

**Sodium deoxycholate, 100 g/l (10% w/v) No. 74**

To make 20 ml:

Sodium deoxycholate\* ..... 2 g  
Sodium chloride, 8.5 g/l\*\* ..... 20 ml

\*Available from Merck/BDH and other chemical manufacturers.

\*\*See Reagent No. 68.

1 Dissolve the chemical in the water. Transfer it to a clean bottle. Sterilize by autoclaving at 121°C for 15 minutes.

2 Label the bottle, and store it at 2–8°C. The reagent is stable for several weeks.

**Sodium hydroxide, 1 mol/l (1N) No. 75**

Purchase ready-made or prepare as follows:

To make 1 litre:

Sodium hydroxide . . . . . 40.01 g  
Distilled water . . . . . to 1 litre

- 1 Weigh the sodium hydroxide, and transfer it to a 1 litre volumetric flask.

**Caution:** Sodium hydroxide is a corrosive deliquescent chemical, therefore handle it with care, and make sure the stock bottle of chemical is tightly stoppered after use.

- 2 Half fill the flask with distilled water, and mix to dissolve the chemical. Make up to the 1 litre mark, and mix well.
- 3 Transfer to a clean bottle (preferably plastic). Label the bottle, and mark it *Corrosive*. Store it at room temperature. The reagent is stable for up to 2 years.

**Sodium nitrite-glucose solution No. 76**

To make 40 ml fresh reagent:

Sodium nitrite . . . . . 0.5 g  
Glucose (dextrose) . . . . . 2.0 g  
Distilled water . . . . . 40 ml

- 1 Weigh the chemicals and transfer them to a container of 50–100 ml capacity.
- 2 Add 40 ml distilled water and mix until the chemicals are completely dissolved.

*Note:* Use on the day of preparation.

**Sorbitol MacConkey agar No. 77**

This medium is best prepared from ready to use dehydrated powder, available from Oxoid Ltd, code CM 0813, and other suppliers.

*Contents:* Sorbitol, peptone, bile salts, sodium chloride, neutral red, crystal violet, agar.

The medium is usually used at a concentration of 5.15 g in every 100 ml distilled water (concentration may vary depending on manufacturer).

Prepare, sterilize, dispense and store the medium as described previously for MacConkey agar, No. 54.

**Tellurite blood agar (TBA) No. 78**

To make 6 plates:

Blood agar\* . . . . . 100 ml  
(use a nutritious agar base)  
Potassium tellurite, 35 g/l (3.5% w/v)\*\* . . . . 1 ml

\*See No. 16.

\*\*Prepare by dissolving 0.7 g potassium tellurite in 20 ml sterile distilled water. When stored at 2–8°C, the solution is stable for up to 6 months. Potassium tellurite is available from Sigma Chemicals, code PO 677 (see Appendix II).

- 1 Prepare the blood agar as described in No. 16. After adding the blood, add aseptically the potassium tellurite solution and mix well. Avoid forming air bubbles.
- 2 Dispense aseptically the medium in about 16 ml amounts in sterile petri dishes. Label the plates 'TBA'. Date the medium and give it a batch number.
- 3 Store the plates at 2–8°C, in sealed plastic bags to prevent loss of moisture.

*Shelf-life:* Up to 10 days providing there is no change in the appearance of the medium to suggest contamination or deterioration.

*pH of medium:* The pH of the base medium should be within the range pH 7.4–7.8 at room temperature.

**Thayer Martin medium (modified) No. 79**

This medium consists of a GC agar base (prepare from dehydrated powder), enriched with haemoglobin and *Vitox* growth factors and made selective for *N. gonorrhoeae* using an antibiotic supplement (VCNT).

- *GC agar base* (e.g. Oxoid product CM 0367): Corn starch, special peptone, sodium chloride, di-potassium hydrogen phosphate, potassium di-hydrogen phosphate, agar.
- *Vitox growth factors* (e.g. Oxoid product SR 0090A): Vitamin B<sub>12</sub>, L-glutamine, adenine SO<sub>4</sub>, guanine HCl, p-aminobenzoic acid, L-cystine, NAD, cocarboxylase, ferric nitrate, thiamine HCl, cysteine HCl, glucose.
- *Antibiotic supplement (VCNT)* (e.g. Oxoid product SR 0091): Vancomycin, colistin methane sulphonate, nystatin, trimethoprim.

To make 500 ml medium:

- 1 Weigh 18 g GC agar base. Add 240 ml distilled water and mix. Gently bring the mixture to the boil (place flask in a container of boiling water) to dissolve the agar. Sterilize by autoclaving at 121°C for 15 minutes.
- 2 Prepare and sterilize the haemoglobin solution.\*

\*Dissolve 5 g haemoglobin powder (e.g. Oxoid product LP 0053) in 250 ml warm distilled water. Sterilize by autoclaving at 121°C for 15 minutes.

- 3 Rehydrate the contents of a vial of *Vitox*

growth supplement as instructed by the manufacturer.

- 4 Rehydrate the contents of a vial of VCNT antibiotic supplement as instructed by the manufacturer.
- 5 Aseptically add the *Vitox* solution to 240 ml of the GC agar base, cooled to 50 °C. Aseptically add the VCNT antibiotic supplement.
- 6 Aseptically add the 250 ml of sterile haemoglobin solution (cooled to 50 °C).
- 7 Mix gently and aseptically pour into sterile petri dishes. Date the medium and give it a batch number.
- 8 Store the plates at 2–8 °C, sealed in plastic bags to prevent loss of moisture.

*Shelf-life:* 4–6 weeks providing there is no change in the appearance of the medium to suggest contamination or deterioration.

#### **Thioglycollate broth** **No. 80**

This medium is best prepared from ready to use dehydrated powder, available from most suppliers of culture media.

*Contents* (USP formula): Yeast extract, tryptone, glucose (dextrose), sodium thioglycollate, sodium chloride, L-cystine, resazurin indicator (less inhibitory than methylene blue), agar.

The medium is usually used at a concentration of 29.5 g in every litre distilled water (concentration may vary depending on manufacturer).

- 1 Prepare as instructed by the manufacturer. Dispense the well mixed medium in 50 ml amounts in bottles fitted with screw-caps that have a central hole and rubber liner. Sterilize by autoclaving (with caps loosened) at 121 °C for 15 minutes.
- 2 When cool, tighten the bottle caps. Cover each bottle top with a foil cap, *Viscap*, or other protective covering (previously soaked in 70% v/v ethanol).
- 3 Label the bottles. Date the medium and give it a batch number. Store in a cool dark place.

*Shelf-life:* Up to 2 years providing there is no change in the volume or appearance of the medium to suggest oxidation or contamination.

*Important:* If at the time of use, more than a narrow band at the surface of the medium appears pink, this indicates oxidation and the

broth should not be used. It should be reheated by placing the bottle in a container of boiling water for about 15 minutes (with bottle cap loosened) to drive off the dissolved oxygen.

#### *Inoculation*

Inoculate the medium as described in subunit 7.14. An aseptic technique is *essential*. Written inoculation instructions should be issued with each bottle of medium. Once inoculated, the broth should be incubated at 35–37 °C as soon as possible.

#### **Thiosulphate citrate bile salt (TCBS) agar** **No. 81**

This medium is best prepared from ready to use dehydrated powder, available from Oxoid Ltd, code CM0333, and other suppliers of culture media.

*Contents:* Yeast extract, peptone, sodium thiosulphate, sodium citrate, ox bile, sucrose, sodium chloride, ferric citrate, brom-thymol blue, thymol blue, agar.

The medium is usually used at a concentration of 8.8 g in every 100 ml distilled water (concentration may vary depending on manufacturer).

- 1 Prepare as described by the manufacturer. Heat the medium with *great care*. It must not be over-heated or autoclaved.
- 2 Dispense aseptically in sterile petri dishes. Date the medium and give it a batch number.
- 3 Store the plates at 2–8 °C, in sealed plastic bags to prevent loss of moisture.

*Shelf-life:* Up to 4 weeks or longer providing there is no change in the appearance of the medium to suggest contamination or alteration of pH.

*pH of medium:* This should be within the range pH 8.4–8.8 at room temperature.

#### **Todd Hewitt enrichment medium** **No. 82**

This medium is best prepared from ready to use dehydrated powder, available from most suppliers of culture media.

*Contents:* Meat infusion, tryptone, glucose, sodium bicarbonate, sodium chloride, di-sodium phosphate.

The medium is usually used at a concentration of 3.64 g in every 100 ml distilled water (concentration may vary depending on manufacturer).

- 1 Prepare the medium as instructed by the manufacturer. Dispense in 3 ml amounts in screw-cap bottles (Bijou type are suitable). Sterilize by autoclaving (with caps loosened)

at 115°C for 10 minutes. When cool, tighten the bottle caps.

- 2 Date the medium and give it a batch number. Store the medium in a cool dark place.

*Shelf-life:* Up to 2 years providing there is no change in the volume or appearance of the medium to suggest contamination or alteration of pH.

*pH of medium:* This should be within the range pH 7.6–8.0 at room temperature.

**Toluidine blue-malachite green reagent** **No. 83**

*To make about 103 ml:*

Toluidine blue*	0.15 g
Malachite green*	0.20 g
Acetic acid, glacial (concentrated)	1 ml
Ethanol or methanol, absolute	2 ml
Distilled water	100 ml

\*Available from Merck/BDH toluidine blue code 340774Y, malachite green code 342265S (see Appendix II).

- 1 Weigh the toluidine blue and malachite green (on pieces of preweighed clean paper). Transfer these to a brown bottle of just over 100 ml capacity.
- 2 Add the acetic acid (*do not* mouth-pipette) and about 30 ml of the water. Mix well to dissolve the stains.
- 3 Add the remaining water and the ethanol or methanol. Mix well.
- 4 Label the bottle, and store it in the dark at room temperature. The stain is stable for several months.

*For use:* Filter a small amount of the reagent into a stain dispensing container.

**Toluidine blue diluting fluid** **No. 84**

*To make 100 ml:*

Toluidine blue*	0.1 g
Sodium chloride, 8.5 g/l**	100 ml

\*Available from Merck/BDH, order No. 34077 4Y (25 g).

\*\*See Reagent No. 68.

- 1 Weigh the toluidine blue on a piece of clean paper (preweighed). Transfer it to a bottle of 100 ml capacity.
- 2 Add about half the saline solution, and mix to dissolve the dye. Add the remainder of the water, and mix well. Label the bottle, and store it at 2–8°C.

*For use:* Filter a small amount of the stain into a brown bottle with a cap into which a dropper can be inserted.

**Toluidine blue, 5 g/l (0.5% w/v)** **No. 85**

*To make 100 ml:*

Toluidine blue	0.5 g
Ethanol, 95% v/v*	20 ml
Distilled water	80 ml

\*Prepare by mixing 1 ml distilled water with 19 ml absolute ethanol (alcohol).

- 1 Weigh the toluidine blue and dissolve in the 95% ethanol. Add the water, mix well, and filter.
- 2 Transfer to a brown bottle and store at 2–8°C.

**Tris – EDTA borate buffer, pH 8.5** **No. 86**

*To make 1 litre:*

Tris – (hydroxymethyl) aminomethane	10.2 g
Ethylenediamine tetra-acetic acid (EDTA)	0.6 g
Boric acid	3.2 g
Distilled water	to 1 litre

- 1 Weigh the chemicals and transfer them to a 1 litre flask.
- 2 About half fill the flask with distilled water and mix to dissolve the chemicals.
- 3 Make up to the 1 litre mark with water. Transfer to a storage container. Label and store at 2–8°C.

**Wayson's stain** **No. 87**

*To make 220 ml:*

Basic fuchsin	0.20 g
Methylene blue	0.75 g
Ethanol or methanol, 95% v/v*	20 ml
Phenol, 50 g/l (5% w/v)**	200 ml

\*Prepare by mixing 1 ml distilled water with 19 ml ethanol (ethyl alcohol) or methanol (methyl alcohol).

\*\*Prepare by dissolving 10 g phenol in 200 ml water. Weigh the phenol with *great care* because it is highly corrosive (see **Caution** under Reagent No. 14).

- 1 Weigh the basic fuchsin and methylene blue, and dissolve these in the 20 ml of alcohol solution.
- 2 Transfer to a brown bottle of 250 ml capacity. With care, add the phenol solution, and mix well.
- 3 Label the bottle, and store it in the dark at

room temperature. The stain is stable for many months.

*For use:* Filter a small amount of the stain into a dropper bottle or other stain dispensing container.

**WBC diluting fluid** **No. 88**

*To make 100 ml:*

- Acetic acid, glacial . . . . . 2 ml
- Distilled water. . . . . 98 ml
- Gentian violet, 1% w/v\* . . . . . 2 ml

\*Prepare by dissolving 0.1 g gentian violet in 10 ml distilled water and filter.

- 1 Fill a 100 ml cylinder to the 98 ml mark with distilled water.
- 2 Add 2 ml concentrated (glacial) acetic acid and mix.

**Caution:** Glacial acetic acid is a corrosive chemical with an irritating vapour, therefore handle it with care and in a well ventilated room. Do *not* mouth-pipette (use a pipette filler).

- 3 Add the gentian violet solution and mix. Transfer to a storage bottle and label. Store in the dark at room temperature.

**Wright's stain** **No. 89**

*To make about 400 ml:*

- Wright stain powder\* . . . . . 1.0 g
- Methanol (methyl alcohol)\*\* . . . . . 400 ml

\*Available from Merck/BDH, code 340804U (see Appendix 11).

\*\*The methanol must be water-free.

- 1 Weigh the Wright powder and transfer it to a *dry* brown bottle. Add a few glass beads (to assist in dissolving the dye).
- 2 Using a *dry* cylinder, measure the methanol and add this to the stain. Mix well at intervals until the powder is completely dissolved. Warming the solution in a 37°C water bath will help the dye to dissolve.

**Caution:** Methanol is toxic and highly flammable, therefore handle it with care well away from an open flame.

- 3 Label the bottle and mark it *Flammable* and *Toxic*. Store it at room temperature in the dark. When kept tightly stoppered, the stain is stable for several weeks. Moisture must *not* be allowed to enter the stain.

*For use:* Allow 3–5 days before using freshly

made stain to allow time for the stain to ‘ripen’. Filter 50–100 ml of the stain into a stain dispensing container which can be closed when not in use.

**Xylose lysine deoxycholate (XLD) agar** **No. 90**

This medium is best prepared from ready to use dehydrated powder, available from Oxoid Ltd, code CM 0469, and other suppliers of culture media.

*Contents:* Yeast extract, L-lysine HCl, xylose, lactose, sucrose, sodium deoxycholate, sodium chloride, sodium thiosulphate, ferric ammonium citrate, phenol red, agar.

The medium is usually used at a concentration of 5.3 g in every 100 ml distilled water (concentration may vary depending on manufacturer).

- 1 Prepare as instructed by the manufacturer. Heat the medium with care and do *not* over heat or autoclave.
- 2 As soon as the medium has cooled to about 55°C, mix well, and dispense aseptically in sterile petri dishes. Label the plates ‘XLD’.
- 3 Date the medium and give it a batch number. Store the plates at 2–8°C, preferably sealed in plastic bags to prevent loss of moisture.

*Shelf-life:* Up to 4 weeks or more providing there is no change in the appearance of the medium to suggest contamination, deterioration, or alteration of pH.

*pH of medium:* This should be within the range pH 7.2–7.6 at room temperature.





# **Appendix II**

## **Useful Addresses**

**Abbott GmbH Diagnostika**

Max-Planck Ring 2  
65205 Wiesbaden  
GERMANY

Phone: +49 6122 5811 77  
Fax: +49 6122 5812 44

E-mail: info-diagnostika@abbott.com  
Website: www.abbott.de

**Acon Laboratories Inc.**

4108 Sorrento Valley Boulevard  
San Diego  
CA 92121  
USA

Phone: +1 858 535 2030  
Fax: +1 858 535 2035

E-mail: info@aconlabs.com  
Website: www.aconlabs.com

**AJ Cope & Sons**

Hackney Road  
London  
E2 9DU, UK

Phone: +44 (0) 2077 292 405  
Fax: +44 (0) 2077 292 657

E-mail: export@ajcope.co.uk  
Website: www.thelabwarehouse.com

**Almedica**

Hauptstrasse 76  
3285 Galmiz  
SWITZERLAND

Phone: +41 26 672 90 90  
Fax: +41 26 672 90 99

E-mail: office@almedica.ch  
Website: www.almedica.ch

**Appropriate Diagnostics Foundation**  
see **Portable Medical Laboratories Inc.**

**Baxter Healthcare Export Corporation**

Wallingford Road  
Compton  
Newbury  
RG20 7QW, UK

Phone: +44 1635 206 000  
Fax: +44 1635 206 115

Website: www.baxter.com

**BD Diagnostics**

21 Betweenstowns Road  
Cowley, Oxford  
OX4 3LY, UK

Phone: +44 (0) 1865 748 844  
Fax: +44 (0) 1865 781 528

Website: www.bd.com

**BDH**

see Merck/BDH

**Binax Inc.**

217 Read Street  
Portland  
ME 04103  
USA

Phone: +1 207 772 3988  
Fax: +1 207 761 2074

E-mail: info@binax.com  
Website: www.binax.com

**Binder Labortechnik GmbH**

Postfach 102  
D-78502  
Tuttlingen  
GERMANY

Phone: +49 7461 1792 0  
Fax: +49 7461 1792 10

E-mail: info@binder-world.co  
Website: www.binder-world.com

**Biomerica Inc.**

1533 Monrovia Avenue  
Newport Beach  
CA 92663  
USA

Phone: +1 949 645 2111  
Fax: +1 949 722 6674

E-mail: info@biomerica.com  
Website: www.biomerica.com

**BioMérieux sa**

Chemin de L'Orme  
69280 Marcy - l'Etoile  
FRANCE

Phone: +33 47887 2000  
Fax: +33 47887 2090

E-mail: info@na.biomerieux.com  
Website: www.biomerieux.com

**Bio Rad Laboratories**

4000 Alfred Nobel Drive  
Hercules  
California 94547  
USA

Phone: +1 510 724 7000

Fax: +1 510 741 5828

Website: [www.bio-rad.com](http://www.bio-rad.com)

**Biotec Laboratories Ltd**

32 Anson Road  
Martlesham Heath  
Ipswich  
IP5 3RG, UK

Phone: +44 (0) 1473 612 158

Fax: +44 (0) 1473 611 476

E-mail: [fbtb@biotec.com](mailto:fbtb@biotec.com)

Website: [www.biotec.com](http://www.biotec.com)

**Boule Diagnostics AB**

Box 1080  
S-14122 Huddinge  
SWEDEN

Phone: +46 8 608 8630

Fax: +46 8 746 8496

E-mail: [info@boule.se](mailto:info@boule.se)

Website: [www.boule.se](http://www.boule.se)

**Chemogen Inc.**

125 John Roberts Road, Suite 5  
South Portland  
Maine 04106  
USA

Phone: +1 207 772 2931

Fax: +1 207 772 2932

E-mail: [info@chemogen.com](mailto:info@chemogen.com)

Website: [www.chemogen.com](http://www.chemogen.com)

**Concept Foundation**

111 Paholyothin Road  
Thailand Science Park  
Klong Luang  
Pathumthani 12120  
THAILAND

Phone: +66 (0) 2564 8021/3

Fax: +66 (0) 2564 8024

E-mail: [joehler@conceptfoundation.org](mailto:joehler@conceptfoundation.org)

Website: [www.conceptfoundation.org](http://www.conceptfoundation.org)

**Developing Health Technology (DHT)**

Bridge House  
Worlington Road  
Barton Mills  
IP28 7DX, UK

Phone: +44 (0) 1638 510 055

Fax: +44 (0) 1638 515 599

E-mail: [dht@gordon-keeble.co.uk](mailto:dht@gordon-keeble.co.uk)

Website: [www.gordon-keeble.co.uk](http://www.gordon-keeble.co.uk)

**Diagnostics for the Real World Ltd**

840 Del Rey Avenue  
Sunnyvale  
California 94085  
USA

Phone: +1 408 773 1511

Fax: +1 408 773 1553

E-mail: [HI207@cam.ac.uk](mailto:HI207@cam.ac.uk)

**Diagnostics Reagents Ltd**

Wenman Road  
Thame  
Oxon  
OX9 3NY, UK

Phone: +44 (0) 1844 212 426

Fax: +44 (0) 1844 216 162

**Diesse Diagnostica Senese Srl**

Via del Pozzo no5-Loc.S Martino  
53035 Monteriggioni  
Siena  
ITALY

Phone: +39 577 319560

Fax: +39 577 318763

**Difco**

Now part of Becton Dickinson  
see **BD Diagnostics**

**Eiken Chemical Co. Ltd**

33-8 Hongo 1-Chome  
Bunkyo-Ku 113-8408  
Tokyo 113-8408  
JAPAN

Phone: +81 338 135 401

Fax: +81 338 132 206

E-mail: [international@eiken.co.jp](mailto:international@eiken.co.jp)

Website: [www.eiken.co.jp](http://www.eiken.co.jp)

**FIND (Foundation for Innovative New Diagnostics)**

71 av. Louis Casai, PO Box 93  
CH-1216 Cointrin/Geneva  
SWITZERLAND

Phone: +41 (22) 710 05 90

Fax: +41 (22) 710 05 99

E-mail: [info@finddiagnostics.org](mailto:info@finddiagnostics.org)

Website: [www.finddiagnostics.org](http://www.finddiagnostics.org)

**FSG Medimedia Ltd**

Vine House

Fair Green

Reach

Cambridge

CB5 0JD, UK

Phone: +44 (0) 1638 743 633

Fax: +44 (0) 1638 743 998

E-mail: [info@fsg.co.uk](mailto:info@fsg.co.uk)

**Fujirebio Diagnostics Inc.**

201 Great Valley Parkway

Malvern

PA 19355-1307

USA

Phone: +1 610 240 3800

Fax: +1 610 240 3803

E-mail: [customerservice@foli.com](mailto:customerservice@foli.com)

Website: [www.FDI.com](http://www.FDI.com)

**Hawksley Ltd**

Marlborough Road

Lancing Business Park

Lancing, Sussex

BN15 8TN, UK

Phone: +44 (0) 1903 752 815

Fax: +44 (0) 1903 766 050

E-mail: [enquiries@hawksley.co.uk](mailto:enquiries@hawksley.co.uk)

**HD Supplies**

44 Rabans Close

Rabans Lane Ind Estate

Aylesbury

HP19 3RS, UK

Phone: +44 (0) 1296 431920

Fax: +44 (0) 1296 392121

E-mail: [hdsupplies@tiscali.co.uk](mailto:hdsupplies@tiscali.co.uk)

**Healthlink Worldwide (formerly AHRTAG)**

56-64 Leonard Street

London

EC2A 4JX, UK

Phone: +44 (0) 20 7549 0240

Fax: +44 (0) 20 7549 0241

E-mail: [info@healthlink.org.uk](mailto:info@healthlink.org.uk)

Website: [www.healthlink.org.uk](http://www.healthlink.org.uk)

**Helena BioSciences**

Colima Avenue

Sunderland Enterprise Park

Sunderland

Tyne & Wear

SR5 3XB, UK

Phone: +44 (0) 191 549 6064

Fax: +44 (0) 191 549 6271

E-mail: [info@helena-biosciences.com](mailto:info@helena-biosciences.com)

**HemoCue AB**

Box 1204

SE 262 23 Ängelholm

SWEDEN

Phone: +46 431 458200

Fax: +46 431 458225

E-mail: [info@hemocue.se](mailto:info@hemocue.se)

Website: [www.hemocue.com](http://www.hemocue.com)

**Hermle Labortechnik GmbH**

Gosheimer Strasse 56

D-78564 Wehingen

GERMANY

Phone: +49 7426 96 22 0

Fax: +49 7426 96 22 49

E-mail: [hermle@hermle.biz](mailto:hermle@hermle.biz)

Website: [www.hermle.biz](http://www.hermle.biz)

**IDL Biotech**

Box 11151

SE-16811 Bromma

SWEDEN

Phone: +46 (0) 8799 6750

Fax: +46 (0) 8799 9320

Website: [www.idl.se](http://www.idl.se)

**Immuno-Mycologies Inc.**

PO Box 1151  
Norman  
Oklahoma 73070  
USA  
Phone: +1 405 288 2383  
Fax: +1 405 288 2228  
E-mail: info@immy.com  
Website: www.immy.com

**Institut Pasteur**

218 rue du Dr Roux  
75724 Paris  
FRANCE  
Phone: +33 (0) 14438 8173  
Fax: +33 14061 3732  
E-mail: fbouzidi@pasteur.fr  
Website: www.pasteur.fr

**J. Mitra, See Mitra, J. & Co Ltd****KIT (Royal Tropical Institute) Biomedical Research**

Meibergdreef 39  
1105 AZ Amsterdam  
The NETHERLANDS  
Phone: +31 20 566 5441  
Fax: +31 20 697 1841  
E-mail: h.schallig@kit.nl

**Laboratorium Hepatika**

Yagasan Hati Sehat  
Jalan Bung Hatta 3A  
Mataram 83231  
Lombok  
INDONESIA  
Phone: +62 370 631662  
Fax: +62 370 635642  
E-mail: hepatika@mataram.wasantara.net.id

**Maco Pharma**

Rue Lorthiois  
59420 Mouvaux  
FRANCE  
Phone: +33 3201 18430  
Fax: +33 3201 18486  
E-mail: contact@macopharma.com  
Website: www.macopharma.com

**Malaysian Bio-Diagnostics Research Sdn Bhd**

Block Intron-Ekson  
UKM-MTDC  
Smart Technology Centre  
43650 Bangi Selangor  
MALAYSIA  
Phone: +60 603 8926 1205/6/7  
Fax: +60 603 8926 1810  
E-mail: info@mbdr.net  
Website: www.mbdr.net

**MAST Group**

Mast House  
Derby Road  
Bootle  
Merseyside  
L20 1EA, UK  
Phone: +44 (0) 151 933 7277  
Fax: +44 (0) 151 944 1332  
E-mail: sales@mastgrp.com  
Website: www.mastgrp.com

**Merck/BDH, see VWR International Ltd****Merck (South Africa)**

1 Friesland Drive  
Longmeadow Business Estate  
Modderfontein, Gauteng  
SOUTH AFRICA  
Phone: +27 11 372 5000  
Fax: +27 11 372 5254  
E-mail: labsupply@merck.co.za

**Millipore UK Ltd**

Units 3 and 5, The Courtyards  
Hatters Lane, Watford  
WD18 8YH, UK  
Phone: +44 (0) 870 900 4445  
Fax: +44 (0) 870 900 4644  
Website: www.millipore.com

**Mitra, J. & Co Ltd**

A-180 Okhla Industrial Area Ph 1  
New Delhi-110020  
INDIA  
Phone: +91 112 681 8971  
Fax: +91 112 681 8970  
E-mail: jmitra@jmitra4u.com  
Website: www.jmitra4u.com

**New Horizons Diagnostics Corporation**

9110 Red Branch Road  
Columbia  
MD 21045  
USA  
Phone: +1 410 992 9357  
Fax: +1 410 992 0328  
E-mail: nhdiag@aol.com  
Website: www.nhdiag.com

**Omega Diagnostics Ltd**

Omega House  
Hillfoots Business Village  
Alva  
Scotland  
FK12 5DQ, UK  
Phone: +44 (0) 1259 763 030  
Fax: +44 (0) 1259 761 853  
E-mail: odl@omegadiagnostics.co.uk  
Website: www.omegadiagnostics.co.uk

**Orchid Biomedical Systems**

Plot No 88/89  
Phase II-C  
Verna Industrial Estate  
Verna-Goa 403 722  
INDIA  
Phone: +91 832 278 3140  
Fax: +91 832 278 3139  
E-mail: orchid-goa@sancharnet.in  
Website: www.tulipgroup.com

**Oxfam**

Oxfam House  
John Smith Drive  
Cowley, Oxford  
OX4 2JY, UK  
Phone: +44 (0) 1865 472 255  
E-mail: publish@oxfam.org.uk

**Oxoid Ltd**

Wade Road  
Basingstoke  
RG24 8PW, UK  
Phone: +44 (0) 1256 841 144  
Fax: +44 (0) 1256 463 388  
E-mail: oxoid@oxoid.com  
Website: www.oxoid.com

**Pacific Biotech**

6 Sonthiwatana 3  
Ladprao 110 Road  
Bangkapi  
Bangkok 10310  
THAILAND  
Phone: +66 2 530 2754  
Fax: +66 2 530 4619  
E-mail: supasorn@brianet.com  
Website: www.pacific-biotech.com

**Palintest Ltd**

Palintest House, Kingsway  
Team Valley  
Gateshead  
Tyne & Wear  
NE11 0NS, UK  
Phone: +44 (0) 191 491 0808  
Fax: +44 (0) 191 482 5372  
E-mail: palintest@palintest.com  
Website: www.palintest.com

**PanBio Ltd**

532 Seventeen Mile Rocks Road  
Sinnamon Park  
Queensland 4073  
AUSTRALIA  
Phone: +61 (0) 7 3363 7100  
Fax: +61 (0) 7 3363 7199  
E-mail: panbio@panbio.com.au  
Website: www.panbio.com.au

**PATH (Program for Appropriate Technology in Health)**

1455 NW Leary Way  
Seattle  
WA 98107  
USA  
Phone: +1 206 285 3500  
Fax: +1 206 285 6619  
E-mail: info@path.org  
Website: www.path.org

**Plasmatec Laboratory Products**

Unit 29 Dreadnought Trading Estate  
Bridport  
Dorset  
DT6 5BU, UK  
Phone: +44 (0) 1308 421 829  
Fax: +44 (0) 1308 421 846  
E-mail: admin@plasmatec.demon.co.uk  
Website: www.plasmatec.uk.com

**Portable Medical Laboratories Inc.**

PO Box 667  
Solana Beach  
California 92075  
USA  
Phone: +1 (858) 755 7385  
Fax: +1 (858) 259 6022  
E-mail: [wsанborn@portmedtech.com](mailto:wсанborn@portmedtech.com)  
Website: [www.portable-medical-lab.com](http://www.portable-medical-lab.com)

**Pro-Lab Diagnostics**

Unit 7, Westwood Court  
Clayhill Industrial Estate  
Neston, Cheshire  
CH64 3UJ, UK  
Phone: +44 (0) 151 353 1613  
Fax: +44 (0) 151 353 1614  
E-mail: [uksupport@pro-lab.com](mailto:uksupport@pro-lab.com)  
Website: [www.pro-lab.com](http://www.pro-lab.com)

**Proteome Systems Ltd**

Locked Bag 2073  
North Ryde 1670 NSW  
AUSTRALIA  
Phone: +61 298 891 830  
E-mail: [info@proteomesystems.com](mailto:info@proteomesystems.com)  
Website: [www.labhoo.com](http://www.labhoo.com)

**Qualpro Diagnostics, see Tulip Group****Quest Diagnostics**

1290 Wall Street West  
Lyndhurst  
NJ 07071  
USA  
Phone: +1 800 222 0446  
Website: [www.questdiagnostics.com](http://www.questdiagnostics.com)

**Roche Diagnostics GmbH**

Sandhoferstrasse 116  
68305 Mannheim  
GERMANY  
Phone: +49 621 759 0  
Fax: +49 621 759 28 90  
Website: [www.roche.de/diagnostics](http://www.roche.de/diagnostics)

**Rosco Diagnostica**

Taastrupgaardsvej 30  
DK-2630 Taastrup  
DENMARK  
Phone: +45 43 99 33 77  
Fax: +45 43 52 73 74  
E-mail: [info@as-rosco.dk](mailto:info@as-rosco.dk)  
Website: [www.rosco.dk](http://www.rosco.dk)

**Royal Tropical Institute (KIT), see KIT****Salubris Inc.**

One Broadway, Suite 600  
Cambridge, MA 02142  
USA  
Phone: +3 314 741 2828  
Fax: +1 617 249 0803  
E-mail: [info@salubrisinc.com](mailto:info@salubrisinc.com)  
Website: [www.salubrisinc.com](http://www.salubrisinc.com)

**Sanofi Diagnostics Pasteur, see Bio-Rad****Sartorius AG**

Weender Landstrasse 94-108  
D-37075 Goettingen  
GERMANY  
Phone: +49 551 3080  
Fax: +49 551 308 3289  
Website: [www.sartorius.com](http://www.sartorius.com)

**Savyon Diagnostics Ltd**

3 Habosem Street  
Ashdod 77610  
ISRAEL  
Phone: +972 8 8562920  
Fax: +972 8 8523176  
Website: [www.savyondiagnosics.com](http://www.savyondiagnosics.com)

**Sibir International AB**

SE-171 54 Solna  
SWEDEN  
Phone: +46 8 501 02508  
Fax: +46 8 501 02598  
Website: [www.sibir.com](http://www.sibir.com)

**Sigma Aldrich Company**

Fancy Road  
Poole, Dorset  
BH12 4QH, UK  
Phone: +44 (0) 1202 712 300  
Fax: +44 (0) 1747 833 524  
Website: [www.sigmaaldrich.com](http://www.sigmaaldrich.com)

**Span Diagnostics Ltd**

173-B New Industrial Estate  
Udhana – Udyognagar 394210  
INDIA  
Phone: +91 261 227 7211  
Fax: +91 261 239 7719  
E-mail: [spand@spandiag.com](mailto:spand@spandiag.com)  
Website: [www.span.co.in](http://www.span.co.in)

**Standard Diagnostics Inc.**

575-34 Pajang-dong, Jangan-ku

Suwon-si

Kyonggi-do

KOREA

Phone: +82 31 258 2994

Fax: +82 31 258 2995

E-mail: taylor@standardia.com

Website: www.standardia.com

**Technical Service Consultants**

The Ropewalk

Schofield Street

Heywood

OL10 1DS, UK

Phone: +44 (0) 1706 620 600

Fax: +44 (0) 1706 620 445

E-mail: sales@tsc-ltd.demon.co.uk

Website: www.tscswabs.co.uk

**Teco Diagnostics**

1268 N. Lakeview Avenue

Anaheim, CA 92807

USA

Phone: +1 714 693 7788

Fax: +1 714 693 3838

E-mail: tecodiag@tecodiag.com

Website: www.tecodiag.com

**Tintometer GmbH**

Schleefstr. 8a

D-44287 Dortmund

GERMANY

Phone: +49 (0) 231 945 100

Fax: +49 (0) 231 945 1030

E-mail: info@tintometer.de

Website: www.tintometer.de

**Trinity Biotech plc**

IDA Business Park

Bray

Co. Wicklow

IRELAND

Phone: +353 1 276 9800

Fax: +353 1 276 9881

E-mail: info@trinitybiotech.ie

Website: www.trinitybiotech.com

**Tulip Diagnostics Tulip Group**

Plot Nos 88/89, Phase 11C

Verna

Goa 403 722

INDIA

Phone: +91 832 278 3140

E-mail: orchid@tulipgroup.com

Website: www.tulipgroup.com

**Unipath Ltd**

Priory Business Park

Bedford

MK44 3UP, UK

Phone: +44 (0) 123 483 5000

Fax: +44 (0) 123 483 5009

E-mail: clearview@unipath.com

Website: www.clearview.com

**VWR International Ltd**

Hunter Boulevard

Magna Park

Lutterworth

LE17 4XN, UK

Phone: +44 (0) 202 660 444

Fax: +44 (0) 202 666 856

E-mail: msgroup@vwr.com

Website: www.vwr.com

**Wagtech International Ltd**

Wagtech Court

Station Road

Thatcham

RG19 4HZ, UK

Phone: +44 (0) 1635 872 929

Fax: +44 (0) 1635 862 898

E-mail: export@wagtech.co.uk

Website: www.wagtech.co.uk

**Wierner Laboratorios S.A.I.C.**

Riobamba 2944

Fe 2000 Rosario

ARGENTINA

Phone: +54 341 432 9191

Fax: +54 341 432 5555

E-mail: wl-mext@satlink.com

Website: www.wiener-lab.com.ar

**Zephyr Biomedicals (Tulip Group)**

Plot Nos. M 46-47

Phase 118 Verna Industrial Estate

Verna Goa - 403 722

INDIA

Phone: +91 832 243 7610

Fax: +91 832 243 7612

E-mail: orchid@tulipgroup.com

Website: www.tulipgroup.com



# Index

- A/AFB**, 39, 40, 41, 73  
**A subgroups**, 363  
**ABO bedside check**, 375  
**ABO blood group system**,  
 ABO subgroups, 363  
 antibodies, 362–363  
 antigens, 362  
 genes, 362  
 grouping techniques, 365–368  
 H substance, 362  
 haemolysins, 363  
 population differences, 363  
 secretors, 362  
**Absidia species**, 245  
**Absolute values (red cell indices)**,  
 312–314  
**Absolute white cell numbers**, 323,  
 324–325  
**Acanthocytes**, 328  
**Acetone-alcohol decolorizer**,  
 38–39, 382  
**Acetyl-L-cysteine reagent**, 246, 282  
**Acid alcohol, 1% v/v**, 40, 215, 382  
**Acid alcohol, 3% v/v**, 40, 382–383  
**Acid citrate dextrose (ACD)**, 383  
**Acid fast bacilli (AFB)**, 39, 40, 41,  
 73, 214  
**Acidified copper sulphate  
 solution**, 60  
**Acidimetric test**, 142–143  
**Acquired immunodeficiency  
 syndrome (AIDS)**, 253,  
 254–256, 257  
**Acridine orange**,  
 preparation, 383  
 use of, 45, 95, 118  
**Actinomyadura madurae**, 217, 239  
**Actinomyadura pelletieri**, 217,  
 239  
**Actinomyces israelii**, 217–218  
**Actinomycetes**, 216–218, 240  
**Actinomycetoma**, 239  
**Actinomycosis**, 217  
**Activated partial thromboplastin  
 time (APTT)**, 341, 343–344,  
 347  
**Active infection**, 15  
**Acute epiglottitis**, 201  
**Acute lymphoblastic leukaemia  
 (ALL)**, 290, 291, 293  
**Acute myeloid leukaemia (AML)**,  
 290, 291, 293  
**Adenoviruses**, 30  
**Adherence fimbriae**, 12  
**Adult T-cell leukaemia/lymphoma  
 (ATL)**, 292  
**Aerobe**, 22, 59  
**Aeromonas species**, 193–194  
**Aerosols**, 9  
**Aerotolerant campylobacters**, 195  
**Aesculin hydrolysis**, 69, 193  
**AFB**, 39, 40, 41, 73  
**African tick typhus**, 229  
**Agar**, 47  
**Agglutination, tests**, 14, 16  
**AHD haemoglobin method**, 299,  
 301, 302  
**AHG crossmatch**, 371–372  
**AHG reagent**, 371, 377  
**AIDS**, 253, 254, 257  
**Albert's iodine**, 44  
**Albert's stain**, 44, 78, 168  
**Albumin crossmatch**, 372–373  
**Albumin in urine (albuminuria)**,  
 112  
**Alcohol fixative for cytology  
 smears**, 383  
**Alcohol saline solution**, 45, 384  
**Alka-Seltzer tablet, use of**, 60, 62  
**Alkaline cellulose acetate  
 electrophoresis**, 337–340  
**Alkaline haematin technique**, 299,  
 302–303  
**Alkaline methylene blue**, see  
**Loeffler methylene blue**  
**Alkaline (pH 8.6) peptone water**,  
 preparation, 384  
 use of, 47, 190  
**Allergic reactions**, 288  
**Allergy**, 74, 288, 375  
**Alpha-haemolysis**, 164  
**Alpha-thalassaemia**, 280, 281, 282  
**Alpha-toxin of C. perfringens**, 171  
**Alphaviruses**, 28, 31  
**Alveolar exudate**, 246  
**American Type Culture  
 Collection (ATCC)**, 50  
**Amies transport medium**,  
 preparation, 384  
 use of, 7, 91, 92  
**Aminoacetophenone production**,  
 194  
**Aminoglycosides**, 133  
**Ammonia water diluting fluid**,  
 303, 385  
**Ammonium oxalate diluting fluid**,  
 317, 385  
**Amoebae**,  
 in cerebrospinal fluid, 122, 124  
 in faeces, 100  
**Amoebic dysentery**, 99  
**Amoebic meningoencephalitis**,  
 122, 124  
**Ampicillin**, 133, 141  
**Anaemia**,  
 aplastic, 279  
 AZT linked, 264, 265  
 blood donors, 353  
 blood loss, 276  
 blood transfusion requirement,  
 349  
 causes, 275–277  
 chronic disease, 279, 309  
 clinical features, 275  
 definition, 274, 275  
 folate deficiency, 276, 278, 309  
 haemolytic, 232, 276, 279–280  
 HIV, 309  
 hypochromic, 277–278,  
 312–313, 328  
 infections, 277  
 iron deficiency, 275–276, 309

- laboratory investigation, 277–280, 308, 309  
 macrocytic, 278, 309  
 malaria, 275  
 megaloblastic, 276, 278  
 microcytic, 277–278  
 normochromic, 278–279  
 severe, 275  
 tropical countries, 275, 309  
 vitamin B<sub>12</sub> deficiency, 276, 278
- Anaerobes**, 22, 59, 205–206
- Anaerobiasis**, 59–62
- Anaerobic cocci**, 165
- Anaerobic culture**, 59–62, 83, 85
- Anaerobic systems**, 61
- Anaerobic streptococci**, 165
- Anaerocult systems**, 59
- Analytical stage**,  
 haematology tests, 270–271  
 microbiological tests, 4–5
- Anaphylactic reactions**, 11, 288
- Anaphylaxis**, 287, 288
- AneroGen system**, 59–60
- Aniline blue**, 396
- Anisocytosis**, 328
- Anonymous mycobacteria**,  
 210–211
- Anthrax**, 83, 166
- Anthrax spores**, 166
- Anti-A, anti-B antisera**, 365–366
- Anti-A, anti-B haemolysins**, 363
- Anti-D antiserum**, 368–369
- Antibiotic associated diarrhoea**,  
 98
- Antibiotic resistance**, 134–135
- Antibiotic susceptibility discs**, 137
- Antibiotic susceptibility  
 (sensitivity) testing**, 132–143
- Antibiotics**, 132–134
- Antibodies**, 11–12
- Antibody tests**,  
 antibody titre, 15  
 brucellosis, 200–201  
 collection of blood, 17  
 dengue, 248–249  
 hepatitis C, 252  
 HIV infection, 258–263  
 leptospirosis, 226  
 principle, 17–18  
 prozone reaction, 17, 201, 220  
 rickettsial infections, 229–230  
 streptococcal infection, 161–162  
 summary, 16–17  
 syphilis, 219–222, 223  
 tuberculosis, 209  
 typhoid, 185–186
- Antibody titre**, 15
- Anticoagulants**,  
 ethylenediaminetetra-acetic  
 acid (EDTA), 297, 299  
 heparin, 297  
*Liquid*, 125, 390  
 sodium citrate, 297, 329–330,  
 403
- Anticoagulated (EDTA) blood**,  
 297, 299
- Antigen A from throat swabs**, 161
- Antigen-antibody reactions**,  
 364–365
- Antigen tests**,  
 camylobacter enteritis, 197  
 chlamydial infection, 234  
 cholera, 191–192  
 cryptococcal infection, 244  
 gonorrhoea, 177  
 hepatitis (HBsAg), 251–252  
 meningitis, 119, 203, 215  
 principle, 14–15  
 streptococcal pharyngitis, 161  
 summary, 16–17
- Antiglobulin reagent**, 371
- Antimicrobial drugs**, 132–134
- Antimicrobial resistance**, 134–135
- Antimicrobial sensitivity discs**, 137
- Antimicrobial sensitivity testing**,  
 132–142
- Antimycobacterial agents**, 133,  
 134
- Antiretroviral drugs**, 264
- Antiretroviral drug regimens**, 264
- Antiretroviral therapy (ART)**,  
 263–266
- Antisera, blood grouping**,  
 365–366, 368–369
- Antistreptolysin O (ASO)**, 161
- Antitoxin, *C. perfringens***, 173
- Aplastic anaemia**, 279
- APTT, 341, 343–344, 347**
- Arabinose fermentation**, 193
- Arboviral infections**, 25, 27, 31–32
- Arboviruses**, 31–32
- Arc of identity**, 170
- Arcobacter* group**, 195
- Arenaviruses**, 28, 31
- Arnold steamer**, 49
- ART**, 263–266
- Arthritis**, 86
- Arthroconidia**, 33, 236, 237
- Arthropod-borne infections**, 25,  
 27, 31–32
- Arthropod-borne viruses**, 31–32
- Arthropod vectors**, 25
- Arthrospore**, 33
- ARV drugs**, 264
- Ascitic (peritoneal) fluid**, 85, 86
- Aseptic (viral) meningitis**, 124
- Aseptic techniques**, 54–55, 126
- ASO antibody**, 161
- ASO latex test**, 161
- Aspergilloma**, 244
- Aspergillosis**, 244
- Aspergillus fumigatus***, 244
- Aspergillus nidulans***, 239
- Aspergillus* species**, 34, 244
- ATCC, control strains**, 50
- Athlete's foot**, 234
- ATP**, 274
- Atypical lymphocytes**, see  
**Reactive lymphocytes**,
- Atypical mycobacteria**, 210
- Atypical pneumonia**, 232
- Auer rods**, 291
- Auramine phenol**,  
 stain, 385  
 technique, 41–42
- Autoagglutination**, 368, 374
- Autoagglutinins**, 368, 374
- Autoantibodies**, 369
- Autoclaving**, 49
- Autologous blood transfusion**, 350
- AZT**, 264, 298
- B19 virus**, 30, 275, 286
- B lymphocytes**, 11, 12, 289
- Bacillary dysentery (shigellosis)**,  
 97, 181
- Bacilli**, 19–20
- Bacillus anthracis***, 166–167
- Bacillus cereus***, 98, 167
- Bacitracin discs**, 160, 385
- Bacitracin sensitivity**, 160
- Bacteraemia**, 124, 125, 183, 257
- Bacteria, features and  
 classification**, 9–25
- Bacterial capsules**, see **Capsules**
- Bacterial cell composition**, 18–19
- Bacterial contamination donor  
 blood**, 358, 374
- Bacterial endocarditis**, 125
- Bacterial index (BI)**, 216
- Bacterial morphology**, 19–22
- Bacterial numbers in urine**, 105,  
 113
- Bacterial reproduction**, 22
- Bacterial vaginosis**, 94
- Bactericidal drugs**, 134
- Bacteriological analysis of water**,  
 149–154
- Bacteristatic drugs**, 134
- Bacteriuria**, 105, 108, 109
- Bacteroides fragilis***, 85, 205–206
- Bacteroides species***, 205
- Bactiburner**, 54
- Balanced polymorphism**, 284
- Band cell**, 287
- Barium chloride (turbidity)  
 standard**, 137
- Barrier filters**, 42, 43
- Bartonella bacilliformis***, 231
- Bartonella henselae***, 231

- Bartonella quintana*, 231  
**Bartonellosis**, 231  
**Basic fuchsin stained faecal smear**, 100, 195  
**Basic media**, 46  
*Basidiobolus* species, 240  
**Basophilia**, 288, 326  
**Basophilic stippling**, 329  
**Basophils**,  
 appearance, 288, 327  
 basophilia, 288, 326  
 functions, 288  
 granules, 288  
 production, 273, 288  
**Battery operated incubator**, 151  
**Baxter blood bags**, 354  
**Bejel**, 224  
**Bence Jones protein**, 294  
**Bengal *V. cholerae* (0139)**, 189–190, 191, 192  
**Beta-galactosidase (ONPG)**, 176, 177, 180  
**Beta-glucuronidase (PGUA) test**, 68  
**Beta-haemolysis**, 77, 159, 160, 162, 172  
**Beta-haemolytic streptococci**, 77, 159, 160, 162  
**Beta-lactam agents**, 133, 141  
**Beta-lactam ring**, 133, 142  
**Beta-lactamase production**, 12, 95, 133, 135, 142, 177  
**Beta-lactamase tests**, 142–143  
**Beta thalassaemia**, 280, 281–282  
**Beta-toxin of *C. perfringens***, 171  
**Bile aesculin slope**, 163  
**Bile solubility test**, 63–64, 164  
**Biochemical testing of microorganisms**, 13, 62–70  
**Bioline tests**,  
 hCG in urine, 115  
**Biological false positive reactions**, 220  
**Biopsies**, 216  
**Biotec FASTplaque TB test**, 210  
**Bipolar staining**, 43–44, 198  
**Black granule eumycetoma**, 239  
**Black stools**, 99  
**Blackwater fever**, see **Malaria haemoglobinuria**  
**Blaser's medium**, 196  
**Blast cell**, 290  
**Blastoconidia**, 32  
*Blastomyces dermatitidis*, 242  
**Blastomycosis**, 242  
**Bleach concentration technique**, 73, 208  
**Bleeding disorders, laboratory investigation**, 340–347  
**Bleeding donors**, 353–357  
**Bleeding time**, 340  
**Blindness caused by trachoma**, 232  
**Blood agar**, 188, 385–387  
**Blood bag (pack)**, 354  
**Blood bank**, 359–361  
**Blood cells**, see **individual cells**  
**Blood clotting factors**, 341  
**Blood coagulation**, 341  
**Blood collection from donors**, 353–357  
**Blood composition**, 272  
**Blood contamination**, 358, 374  
**Blood cultures**,  
 collection of blood, 125–127  
 contamination of cultures, 130  
 culture media, 125–126, 127  
 microscopy, 127  
 neonates, 127  
 pathogens, 125  
 subculture, 128  
**Blood donation**, 352–357  
**Blood donor questionnaire**, 352–353  
**Blood donor records**, 358–359  
**Blood donor recruitment officer**, 352  
**Blood (donor), storage**, 359–360  
**Blood donors**,  
 collecting blood, 353–357  
 health check, 353  
 HIV counselling, 353  
 records, 358–359  
 requirements, 352–353  
 voluntary, 352  
**Blood films**,  
 cell changes due to EDTA, 298–299  
 differential cell count, 323–329  
 fixing, 321  
 preparation, 321–323  
 reporting, 323–329  
 spreading, 320–321  
 staining, 270, 321–322  
**Blood, functions of**, 272  
**Blood grouping**, 362–369  
**Blood grouping antisera**, 365–366, 368–369  
**Blood grouping techniques**,  
 ABO, 365–368  
 Rhesus, 368–369  
**Blood groups**, 362–364  
**Blood transfusion**,  
 appropriate use, 348, 349  
 autologous, 349–350  
 bedside check, 375  
 compatibility testing, 369–375  
 exchange transfusion, 349, 377, 378  
 need for, 348, 349  
 practice at district level, 348–350  
 reaction, 375–376  
 request form, 370  
 safety, 348, 357–358, 374–375  
 selecting blood, 370  
 transfusing young children, 349  
 treating anaemia, 349  
**Body's defence mechanisms**, 10–12  
**Bone marrow**, 273, 278, 293  
**Borderline leprosy (BT, BB, BL)**, 213  
*Bordetella parapertussis*, 205  
*Bordetella pertussis*, 205  
**Boric acid preservative**, 106  
*Borrelia* species,  
*B. burgdorferi*, 228  
*B. duttoni*, 227  
*B. recurrentis*, 227  
*B. vincentii*, 228  
 Giemsa staining, 44–45  
**Botulism**, 173  
**Bound coagulase**, 65, 66  
**Brazilian purpuric fever (BPF)**, 203  
**Brill-Zinsser disease**, 229  
**Brilliant cresyl blue**, 332, 387  
**Broad-spectrum antibiotics**, 134  
**Bronchial washings**, 246  
**Broncho-alveolar lavage**, 246  
**Bronchopneumonia**, 71, 72  
**Brownian movement**, 35  
*Brucella abortus*, 125, 199, 200  
*Brucella* antibodies, 200–201  
*Brucella melitensis*, 199  
*Brucella* species, 199–201  
*Brucella suis*, 199, 200  
**Brucellosis**, 125, 126, 199–200  
**Brucellosis IgM/IgG rapid test**, 200–201  
**Bubo**, 198  
**Bubonic plague**, 82, 83, 198  
**Buffer indicator solution, pH 7.2**, 168, 387  
**Buffered carbohydrate solutions**, 168  
**Buffered saline**, 402–403  
**Buffered water**,  
 pH 6.8, 322, 387–388  
 pH 7.0–7.2, 44, 387–388  
 pH 8.0, 387–388  
**Buffy coat smears**, 127  
**Bulb pipettes**, 314  
**Bunsen burner**, 54  
**Bunyamwera virus**, 28  
**Bunyaviruses**, 28, 31  
**Bürker chamber**, 314  
*Burkholderia pseudomallei*, 195, 198

- Burkitt's lymphoma**, 30, 292  
**Burr cells**, 328  
**Buruli ulcer**, 82, 211, 212  
**Butzler medium**, 196
- Calcium chloride reagent**, 343  
**Calcium oxalate crystals**, 111  
**Calcium pyrophosphate crystals**, 88  
**Calci virus**, 29  
**Calcofluor white**, 34  
**Calculi (stones)**, 111  
**Calibrated wire loops**, 113  
***Calymmatobacterium granulomatis***, see *Klebsiella granulomatis*  
**CAMP test**, 163, 173  
***Campylobacter coli***, 195–197  
***Campylobacter enteritis***, 195  
***Campylobacter jejuni***, 195–197  
***Campylobacter species***, 61, 98, 100, 195–197  
**Campylobacters**, 195  
***Candida albicans***, 76, 92, 243–244  
***Candida dubliniensis***, 244  
**Candidiasis**, 92, 93, 94, 243–244  
**Candle jar**, 61  
**Capillary blood, collection**, 295–296  
**Capillary tubes for PCV**, 310  
**Capillus HIV test**, 261  
**Capsid of viruses**, 26  
**Capsomeres**, 26  
**Capsular antigens**, 19, 119, 176, 178  
**Capsules**, 19, 43, 163, 166, 244  
**Carate**, 224  
**Carbapenems**, 133  
**Carbohydrate fermentation tests**, 63, 168–169, 175  
**Carbohydrate indicator solutions**, 168  
**Carbohydrate utilization test**, 168–169  
**Carbol fuchsin**, dilute, 38  
   preparation, 388  
   use of, 40–41  
**Carbon dioxide enriched atmosphere**, 61–62  
**Carbon dioxide incubation**, 61–62  
**Carboxiphilic organism**, 59  
**Cardiolipin antibodies**, 219, 220, 223  
**Cardiolipin tests**, 219, 220, 223  
**Carriers of pathogens**, 10  
**Carrion's disease**, 231  
**Cary-Blair transport medium**, preparation, 388–389  
   use of, 99
- Caseous material**, 73  
**Castaneda culture medium**, 126  
**Casts**, 108, 109, 110  
**Catalase enzyme activity**, 64  
**Catalase test**, 64–65  
**CD4 cell counting**, 257–258  
**CD4+ T lymphocytes**, 12, 254, 257, 290  
**CD8+ T lymphocytes**, 12  
**Cefinase discs**, 142  
**Cell count**, cerebrospinal fluid, 119–120  
   effusion, 87  
**Cell-mediated immune response**, 12  
**Cell wall of bacteria**, 19  
**Cells**, in cerebrospinal fluid, 119–120  
   in effusion, 87  
   in urine, 108  
**Cellular casts**, 109, 110  
**Cellular immunity**, 12  
**Cellulose acetate electrophoresis**, 337–340  
**Cellulose acetate paper (membrane)**, 337–338  
**Centrifuge, microhaematocrit**, 310, 311  
**Cephalosporins**, 133, 141  
**Cerebrospinal fluid**, acridine orange smear, 118  
   amoebae in, 116, 122  
   antigens, 119, 163, 176, 203  
   antimicrobial sensitivity testing, 124  
   appearance of, 117  
   blood in, 117  
   cell count, 119–120  
   clots in, 117  
   collection of, 116–117  
   culture of, 119, 122–124  
   examination (summary), 123  
   Giemsa preparation, 122  
   globulin (Pandy's) test, 121  
   glucose estimation, 120–121, 124  
   Gram smear, 118, 175  
   IgM, 122  
   India ink preparation, 121–122  
   lymphocytic meningitis, 116  
   neurosyphilis, 222  
   pathogens in, 116, 170  
   protein estimation, 121  
   pyogenic meningitis, 116, 124, 175  
   trypanosomes, 117, 122  
   viral meningitis, 124  
   wet preparation, 122  
   Ziehl-Neelsen smear, 121, 124
- Cervical smears for malignant cells**, 93  
**Cervical specimens**, collection, 92–93  
   examination, 90–97  
   pathogens, 90–91  
**CFU (progenitor blood cells)**, 273  
**CFU (urine)**, 113  
**Chancre (syphilitic)**, 91, 92, 95  
**Chancroid**, 91, 93, 204, 218  
**Charcoal cephalixin blood agar (CCBA)**, preparation, 389  
   use of, 205  
**Chikungunya virus**, 28  
**Chlamydia antigen tests**, 233, 234  
***Chlamydia pneumoniae***, see *Chlamydia pneumoniae*  
***Chlamydia species***, 21, 231–234  
***Chlamydia trachomatis***, antigen tests, 234  
   Giemsa staining, 44–45, 233  
   immunological diagnosis, 234  
   inclusion bodies, 45, 233  
   inclusion conjunctivitis, 232  
   iodine staining, 233  
   lymphogranuloma venereum (LGV), 90–92, 93, 232  
   neonatal ophthalmia, 232  
   non-gonococcal urethritis, 90, 94, 232  
   pathogenicity, 231–232  
   trachoma, 232–233  
   urogenital infections, 90, 93, 232–233  
***Chlamydia pneumoniae***, 233  
**Chlamydospores**, 240  
**Chloramphenicol**, 133, 134, 141  
**Chlorinated water supplies**, 151–152  
**Chlorine testing of water**, 154–155  
**Chlorohaemin**, 299, 302  
**Chocolate (heated blood) agar**, 386  
**Cholera**, 98, 189–190  
**Cholera dipstick test**, 191–192  
**Cholera toxin**, 190  
**Cholesterol crystals**, 111  
**Choriocarcinoma**, 115  
**Christensen's urea broth**, 70, 197, 389–390  
**Chromoblastomycosis**, 238  
**Chronic lymphocytic leukaemia (CLL)**, 291, 293  
**Chronic myeloid leukaemia (CML)**, 291, 293  
**Chyle in urine**, 107  
**Circulating anticoagulant (inhibitor)**, 343  
**Citrate-utilization test**, 65, 180

- Citrate-utilizing bacteria**, 180  
*Citrobacter freundii*, 180  
*Cladosporium carrionii*, 238  
**Classes of immunoglobulin (Ig)**, 11  
**Classical *Vibrio cholerae***, 189  
**Classification of microorganisms**, 9–10, 18–22, 23–25  
**CLED agar**, 113, 391  
*Clostridium botulinum*, 173–174  
*Clostridium difficile*, 98  
*Clostridium histolyticum*, 172  
*Clostridium novyi*, 171, 172  
*Clostridium perfringens*, 98, 171–173, 309  
*Clostridium septicum*, 171, 172  
*Clostridium sordellii*, 172  
*Clostridium tetani*, 174  
**Clotted blood for antibody tests**, 17  
**Clotting time**, 346  
**Clue cells**, 94  
**CMM**, see **Cooked meat medium**  
**CMV**, see **Cytomegalovirus**  
**Coagglutination (COAG)**, 14, 16  
*CoaguChek S* meter, 345  
**Coagulase production**, 65  
**Coagulase tests**, 65–67  
**Coagulation disorders**, 340, 341  
**Coagulation factors**, 341  
**Cocci**, 19, 20  
*Coccidioides immitis*, 242–243  
**Cold agglutinins**, 369  
**Cold Ziehl-Neelsen staining technique**, 39–40  
**Coliform (*E. coli*) count**, 149–154  
**Collecting blood from donors**, 353–357  
**Collection and transport of microbiological specimens**, ascitic (peritoneal) fluid, 86–87  
 blood (antibody testing), 17  
 blood (cultures), 125–127  
 broncho-alveolar lavage, 246  
 cerebrospinal fluid, 116–117  
 cervical swab, 92, 93, 233  
 control of specimen collection, 5–7  
 effusions, 86–87  
 endocervical, 92, 233  
 faecal specimens, 98–99  
 fungal specimens, 235–236  
 genital specimens, 91–92, 233  
 hydrocele fluid, 86–87  
 mouth swab, 76–77  
 packing, 8  
 pericardial fluid, 86–87  
 pleural fluid, 86–87  
 preservatives, 7  
 pus, 81–82  
 quality control, 6–8  
 rectal swab, 98–99  
 semen, 130–131  
 serum, 17  
 skin, 81–82  
 skin smears for leprosy, 214–215  
 sputum, 71–72  
 stool specimens, 98–99  
 throat swab, 76–77  
 transport, 7  
 ulcer material, 81–82  
 urine, 106–107  
 urogenital specimens, 91–92, 233  
 vaginal discharge, 92  
 water for testing, 147–149  
**Collection of haematological specimens**, 269–270, 296–299  
**Colloidal gold**, 15, 18  
**Colloids, use of**, 349  
**Colonial appearances**, bacterial, 47  
 fungal, 34  
**Colony-forming units in urine**, 113  
**Columbia agar and broth diphasic medium**, 125–126, 175, 390  
**Commensals**, 23  
**Communicable diseases**, 10–11  
**Compatible blood, labelling**, 374  
**Compatibility testing**, 369–375  
**Complement activity**, 11  
**Complex viruses**, 26  
**Composition of blood**, 272  
**Concentrated red cells**, 349, 375  
**Concentrating tubercle bacilli**, 73, 208  
**Confidence limits for water tests**, 150  
**Congenital syphilis**, 218–219, 224  
**Conidia**, 33  
**Conidiophore**, 33  
**Conjunctival scrapings**, 233, 234  
**Conjunctivitis**, 176, 232  
**Contamination**, faecal, 144  
 of bank blood, 130  
 of cultures, 130  
 of hands, 144, 145  
 of water supplies, 147  
**Control blood and haemolysate**, 270  
**Control species**, 50, 51, 52  
**Control strains, sensitivity testing**, 138  
**Convalescent serum**, 15  
**Cooked meat medium**, preparation, 390–391  
 use of, 60, 85, 94, 172, 174  
**Copper coated steel wool**, 60  
**Co-receptors CCR5, CXCR4**, 254  
**Coronaviruses**, 29  
*Corynebacterium diphtheriae*, 44, 76, 78, 79, 167–170  
*Corynebacterium ulcerans*, 169  
**Cotton blue**, 242, 396  
**Counselling (HIV)**, 258  
**Counting cells**, CD4+ T cells, 257–258  
 platelets, 317–319  
 reticulocytes, 331–332  
 white cells, 313–317  
**Counting chamber**, Bürker, 314  
 Fuchs Rosenthal, 120  
 Improved Neubauer, 120, 314, 315–316  
**Counting faecal coliforms**, 149–154  
**Cover glasses for haemocytometer**, 314  
*Coxiella burnetii*, 230–231  
**Coxsackieviruses**, 29  
**CPD-NaCl solution**, 389  
**CPDA anticoagulant**, 354  
**Crimean-Congo haemorrhagic fever virus**, 27, 28  
*Cristaseal*, 310  
**Crossmatching**, 369–375  
**Cryptococcal meningitis**, 116, 121–122, 124, 244  
**Cryptococcosis**, 244  
**Cryptococcus antigen test**, 244  
*Cryptococcus neoformans*, 116, 121–122, 124, 244  
**Crystal violet blood agar**, 160, 387, 391  
**Crystal violet in Gram stain**, 38–39, 391  
**Crystalline penicillin bromocresol purple solution**, 142, 391  
**Crystals**, in synovial (joint) fluid, 88  
 in urine, 111  
**CSF**, see **Cerebrospinal fluid**  
**Culti-Loops**, 50  
**Culture media**, basic, 46  
 control strains, 52  
 differential, 46  
 dispensing, 53–54  
 enriched, 46  
 inoculating, 54–56  
 labelling, 51–52  
 pH, 49  
 pouring, 53–54  
 preparation of, 48–49  
 quality control, 48–49, 51–52  
 selective, 46, 51

- sterilizing, 49–50  
 storage of, 51–53  
 transport media, 46–51  
 weighing, 48
- Culturing microorganisms,**  
 anaerobic, 59–62  
 carbon dioxide, 61–62  
 features, 13, 22  
 fungi, 34  
 reporting cultures, 62  
 requirements, 45–62
- Curettings,** 93
- Cutaneous anthrax,** 81, 83, 166
- Cutaneous diphtheria,** 167
- Cyanmethaemoglobin technique,**  
 299, 300–301
- Cystine crystals,** 111
- Cystine lactose electrolyte deficient agar (CLED),**  
 preparation, 391  
 use of, 113, 187, 188
- Cystitis,** 105, 178
- Cysts of *Pneumocystis*,** 246–247
- Cytochemical staining,** 291, 293
- Cytochrome oxidase test,** 69–70
- Cytokines,** 11, 288
- Cytology smear for malignant cells,** 93, 383
- Cytomegalovirus,** 27, 30
- Cytoplasmic membrane,** 19
- Cytotoxic T lymphocytes,** 12, 289
- Cytotoxins,** 289
- D-Dimers,** 346, 347
- Dane particles,** 250
- Dangerous pathogens,** 7
- Dark-field microscopy,** 36, 95, 121
- Dark-field stops,** 36, 95
- Darkground illumination, see**  
**Dark-field microscopy**
- DAT (direct antiglobulin test),**  
 276, 280, 286, 377
- DCA,** 179
- Deep mycoses,** 33
- Deep (stab) media,** 56, 57
- Defence mechanisms of the body,**  
 11–13
- Dehydrated media,** 47–48
- DelAgua water testing kit,** 153
- Delta agent (particle),** 30, 251
- DEN/DHF,** 248
- Dengue antibody tests,** 248–249
- Dengue Duo IgM/IgG test,** 249
- Dengue Fever IgM/IgG, IC test,**  
 249
- Dengue haemorrhagic fever (DHF),** 248
- Dengue shock syndrome (DSS),**  
 248
- Dengue viruses,** 248–249
- Dental caries,** 164
- Deoxycholate citrate agar (DCA),**  
 preparation, 391–392  
 use of, 179
- Deoxyribonuclease (DNA-ase) test,** 67
- Deoxyribonucleic acid (DNA),**  
 22
- Dermatophytes (ringworm fungi),**  
 234–238
- Determine HIV 1/2 test,** 262–263
- Dextrose broth,** 394
- DHF,** 248
- DHT Haemoglobin Meter,**  
 303–304
- Diagen coagulation reagents,** 343,  
 345, 346
- Diagel Bedside card,** 375
- Diagnostic discs,**  
 antimicrobial, 137  
 bacitracin, 160  
 optochin, 164
- Diarrhoeal diseases,** 97–98, 100,  
 178, 183, 195, 257
- DIC,** 346, 347
- Dichroic mirror,** 42
- Differential culture media,** 46, 50
- Differential WBC count,** 323–329
- Differential WBC counter,** 324
- Diffusion sensitivity tests,** 136–137
- Diluting fluids,**  
 ammonia water, 303, 385  
 ammonium oxalate, 317, 385  
 c.s.f. diluting fluid, 119  
 sodium bicarbonate-formalin,  
 132, 403  
 toluidine blue, 119, 406
- Dilution sensitivity tests,** 136
- Dimethylsulphoxide-KOH (DMSO) reagent,** 236, 392
- Dimorphic blood picture,** 327
- Dimorphic fungi,** 33
- Diphasic blood culture medium,**  
 126
- Diphtheria,** 78, 167
- Diphtheria antitoxin,** 167
- Diphtheroids,** 168
- Dipslides,** 106–107
- Dipstick comb assays,** 15, 16, 18
- Direct antiglobulin test (DAT),**  
 276, 280, 286, 377
- Disc diffusion sensitivity tests,**  
 136–137
- Discs**  
 bacitracin, 160, 385  
 optochin, 164  
 sensitivity, 137
- Dispensing culture media,** 53–54
- Disseminated intravascular coagulation (DIC),** 346, 347
- Distilled water motility test,**  
 193–194
- District laboratories,**  
 blood transfusion, 348–351  
 haematology, 268  
 microbiology, 1–9
- Dithiothreitol,** 74
- DMSO reagent,** 236
- DNA, see** Deoxyribonucleic acid
- DNA hybridization,** 182
- DNA viruses,** 29–30
- DNA-ase agar,** 67, 392
- DNA-ase B antibody,** 161–162
- DNA-ase test,** 67
- Donor blood,**  
 bacterial contamination, 130,  
 358, 374  
 collecting, 353–357  
 records, 358–359, 361  
 storage, 359–360  
 testing for pathogens, 357–358  
 transporting, 360–361
- Donovan bodies,** 95
- Donovanosis,** 91, 95
- Dorset egg medium,** 54, 168,  
 392–393
- DOTS,** 210
- DPD method for estimating free chlorine,** 154–155
- 2–3 DPG,** 274
- Drabkins diluting fluid,** 300
- Drinking water supplies, see**  
**Water**
- Drug hypersensitivity,** 133
- Drug resistance,** 1, 134–135
- Drug toxicity, antiretroviral drugs,**  
 264
- Dryspot *Campylobacter* test,** 197
- Dryspot *Staphylect Plus*,** 158
- DSS, see** Dengue shock syndrome
- Duffy blood group system,** 369
- Durham tube,** 402
- Dysentery,** 97, 181
- Ebola virus,** 27, 28, 31–32
- EBV, see** Epstein-Barr virus
- Echinocytes,** 328
- Echoviruses,** 29
- Ectopic pregnancy,** 115, 176, 232,  
 350
- Ectothrix, hair,** 237
- EDTA,** 297
- Effusions,**  
 collection, 86–87  
 examination of, 85–90  
 pathogens, 86
- EHEC, see** Enterohaemorrhagic  
*E. coli*
- EIA,** 14, 16
- EIEC, see** Enteroinvasive *E. coli*

- El Tor *Vibrio cholerae***, 98, 189  
**Electronic blood cell counting**, 319  
**Electrophoresis (Hb)**, 337–340  
**Elek gel precipitation test**, 169–170  
**Elementary particles**, 21, 234  
**ELISA**, see **Enzyme linked immunosorbent**  
**Elliptocytosis**, 286  
**Emergency blood grouping**, 367  
**Emergency compatibility testing**, 373, 374  
**Emerging pathogens**, 1  
**Empyema**, 86  
**Encephalitis viruses**, 32  
**Endemic disease**, 9  
**Endemic flea-borne typhus**, 229  
**Endemic typhus**, 229  
**Endocarditis**, 164  
**Endospores**, 19  
**Endothrix hair**, 237  
**Endotoxin**, 13  
**Enriched media**, 46  
**Enrichment media**, 46  
***Entamoeba histolytica***, 97, 100  
**Enteric anthrax**, 166  
**Enteric fever**, 182–183  
**Enteritis necroticans**, 98  
**Enterohaemorrhagic *E. coli* (EaggEC)**, 178  
***Enterobacter* species**, 187–188  
**Enterobacteria**, 178, 180  
***Enterochek-WB***, 185–186  
**Enterococci**, 69, 165  
**Enterohaemorrhagic *E. coli* (EHEC, 0157)**, 98, 105, 178, 179  
**Enteroinvasive *E. coli* (EIEC)**, 98, 178  
**Enteropathogenic *E. coli* (EPEC)**, 98, 178  
**Enterotoxigenic *E. coli* (ETEC)**, 98, 178  
**Enterotoxin**, 12, 171, 190  
**Enteroviruses**, 29  
**Envelope of virus**, 26, 27  
**Environmental mycobacteria**, 210  
**Enzyme linked immunosorbent assay (ELISA)**, 14, 17  
**Eosin faecal stain**, 100, 393  
**Eosinophils**,  
     appearance, 287, 327  
     eosinophilia, 326  
     functions, 287–288  
     granules, 287  
     production, 273, 287  
**Eosinophils in sputum**, 74  
**EPEC**, see **Enteropathogenic *E. coli***  
**Epidemic**, 9  
**Epidemic typhus**, 229  
**Epidemiology**, 9  
***Epidermophyton floccosum***, 235  
**Epithelial cells in urine**, 109, 110  
**Epstein-Barr virus (EBV)**, 30  
**Erysipeloid**, 171  
***Erysipelothrix rhusiopathiae***, 81, 171  
**Erythrocyte sedimentation rate (ESR)**, 329–331  
**Erythrocytes**, see **Red cells**  
**Erythromycin**, 141  
**Erythropoiesis**, 272–274  
**Erythropoietin**, 272  
***Escherichia coli***, 67–68, 98, 101, 149–154, 178–179, 180  
**ESR**, 329–331  
**ETEC**, see **Enterotoxigenic *E. coli***  
***Etest***, 140, 142  
**Ethylenediamine tetra-acetic acid (EDTA)**, 397, 299, 393  
**Ethylhydrocupreine hydrochloride discs**, 164  
**Eumycetoma**, 239  
**Evacuated tube collection systems**, 298  
**Exchange blood transfusion**, 349, 377, 378  
**Exciter filter**, 43  
***Exophiala jeanselmei***, 239  
**Exotoxins**, 12, 98, 167, 211  
**External quality assessment (EQA)**,  
     haematology tests, 270  
     microbiology tests, 5  
**Extramedullary haematopoiesis**, 272  
**Extravascular haemolysis**, 279  
**Extrinsic system**, 341, 343  
**Exudate**, 3, 85, 88  
**Eye scrapings**, 233  
**FAB classification**, 291  
**Facultative anaerobes**, 22  
**Faecal coliform count**, 149–154  
**Faecal leucocytes**, 100  
**Faecal-oral route of transmission**, 144, 190  
**Faecal pollution of water**, 146  
**Faecal specimens**,  
     collection, 98–99  
     examination, 97–105  
     pathogens, 97–98, 99, 100, 181  
**Falciparum malaria**, 284, 309, 327  
***FAST* plaque TB test**, 210  
**Favic hair**, 235, 237  
**Favism**, 285  
**FDP levels**, 346  
**Febrile antigen tests**, 185  
**Ferritin, serum**, 278, 281  
**Fibrinogen**, 341, 342  
**Fibrinolysis**, 346  
**Fièvre boutonneuse**, 229  
**Filoviruses**, 28, 31–32  
**Filters, membrane**, 49–50, 150  
**Filtration**,  
     isolating campylobacters, 195–196  
     media ingredients, 49–50  
     water testing, 150  
**Filtration HbS solubility test**, 336–337  
**Fimbriae, adherence**, 12, 19  
**FIND Foundation**, 209  
**Fixing blood films**, 321–322  
**Fixing smears**,  
     bacterial, 36–37, 166, 177  
     blood films, 321–322  
     cytological, 90  
**Flagella**, 19  
**Flagellar(H)antigens**, 178  
**Flame sterilization**, 54  
**Flaviviruses**, 28, 31, 248  
**Flea-borne typhus**, 229  
**Flocculation tests**, 16, 17  
**Flora, microbial**, 22–23, 62  
**Fluid culture media**, 47, 56  
**Fluorescence microscopy**, 41–43, 45, 209  
**Fluorescence of fungal lesions**, 235, 238  
**Fluorescence of hair**, 235  
**Fluorescence staining**, 14, 41–43  
**Fluorescent antibody tests**, 14  
**Fluorescent treponemal antibody test (FTA-ABS)**, 221, 223  
***FloreslenS***, 42–43  
**Fluorochrome**, 14, 17–18  
     acridine orange, 45  
     auramine, 41  
     calcofluor white, 34  
     fluorescein isothiocyanate, 14  
**Folate deficiency**, 276, 278, 309  
**Food-poisoning**,  
     *Bacillus cereus*, 167  
     *Clostridium botulinum*, 173  
     *Clostridium perfringens*, 171, 172  
     *Salmonella*, 183  
     *Staphylococcus aureus*, 157  
**Formol saline fixative**, 393  
**Framboesia**, 224  
**Free coagulase**, 65, 66  
**Free residual chlorine testing**, 154–155  
**FTA-ABS**, 221, 223  
**Fuchs-Rosenthal ruled chamber**, 119, 120

- Fungal hyphae**, 32–33  
**Fungal infections**, 33–34  
**Fungal mycetoma**, 238–239  
**Fungal specimens**, 235–236  
**Fungi**, 32–35  
**Fungus ‘ball’**, 244  
***Fusobacterium* species**, 205, 206, 228  
  
**G6PD deficiency**, 285–286, 309, 334  
**G6PD screening test (methaemoglobin reduction)**, 333–334  
***Gardnerella vaginalis***, 91, 94  
**Gas gangrene**, 171  
**Gas refrigerator blood bank**, 359–360  
**Gaseous atmosphere for cultures**, 59  
***GasPak***, 61  
**Gastritis caused by *H. pylori***, 197  
**Gastroenteritis**, 97  
**Gel blood grouping systems**, 364  
**Gelatin stab culture**, 167  
**Genital herpes**, 93  
**Genital specimens**, see **Urogenital specimens**  
**Genital ulcers**, 90, 92  
**Gentamicin**, 133  
**Gentian violet in donor blood**, 358  
**Germ tube test**, 243–244  
**Ghost cells**, 285, 328  
**Giemsa stain**,  
    preparation, 393–394  
    use of, 44–45, 122, 247  
**Gingivitis**, 228  
**Glandular fever**, 30, 294–295  
**Glass tubing for Pasteur pipettes**, 58  
**Globi**, 214  
**Globulin detection in c.s.f.**, 121  
**Glomerulonephritis**, 108, 161  
**Glucose broth**, 394  
**Glucose estimation in c.s.f.**, 120–121, 124  
**Glucose 6 phosphate dehydrogenase (G6PD) deficiency**, 285–286, 309, 334  
**Glucose phosphate peptone water**, 394  
**Glutamic acid**, 283  
**Glutamyl-aminopeptidase (GAP)**, 176, 177  
**Glycerol saline transport medium**, 394–395  
**Glycopeptides**, 133  
  
**Gonococcal conjunctivitis**, 176  
**Gonococci**, see *Neisseria gonorrhoeae*  
**Gonorrhoea**, 90, 176  
**Gout**, 88  
**Grains in mycetoma**, 82, 239  
**Gram negative bacteria**, 22, 38  
**Gram positive bacteria**, 22, 38  
**Gram staining**, 38–39  
**Gram’s iodine**, see **Lugol’s iodine**  
**Granular casts**, 110  
**Granules in actinomycosis**, 217  
**Granules in mycetoma**, 82, 239  
**Granules in pus**, 82, 217, 239  
**Granuloma inguinale**, 91  
**Gravis biovar of *C. diphtheriae***, 167, 168  
**Greiss test**, 112  
**Grid membrane filters**, 150  
**Group A meningococci**, 175  
**Group A *Streptococcus***, 159, 160  
**Group B meningococci**, 175  
**Group B *Streptococcus***, 162–163  
**Group C meningococci**, 175  
**Group D streptococci**, see *Enterococcus*  
**Grouping**, see **Blood grouping**  
  
**H agglutinin titre**, 185  
**H antigens**, 178  
**H substance**, 362  
**HAART**, 264  
**Haem**, 274  
**Haemagglutination test for *V. cholerae* biovars**, 191  
**Haematocrit centrifuge**, 310, 311  
**Haematocrit in DHF**, 248  
**Haematocrit, measurement**, 310–312, 249  
**Haematoma**, 298, 356  
**Haematopoiesis**, 272–274  
***Haematospin 1300***, 310, 311  
**Haematuria**, 108, 109  
**Haemiglobincyanide (cyanmethaemoglobin) technique**, 299, 300–301  
**Haemocytometer**,  
    Bürker, 314  
    Fuchs Rosenthal, 120  
    Improved Neubauer, 120, 314, 315–316  
**Haemoglobin**,  
    abnormal forms, 283–285  
    adult, 274  
    anaemia, 274–280  
    fetal, 274  
    haemoglobinopathies, 283–285  
    measurement, 299–307  
    oxygen dissociation, 274  
    reference range, 307  
    structure, 274  
    values, 275, 307  
**Haemoglobin A**, 274, 282  
**Haemoglobin A<sub>2</sub>**, 274, 282  
**Haemoglobin Barts hydrops syndrome**, 281, 282  
**Haemoglobin C**, 284, 339, 340  
**Haemoglobin chains**, 274, 280, 283  
**Haemoglobin Colour Scale**, 306–307, 353  
**Haemoglobin Constant Spring**, 281  
**Haemoglobin D**, 283, 340  
**Haemoglobin D<sup>Punjab</sup>**, 284  
**Haemoglobin E**, 285, 340  
**Haemoglobin electrophoresis**, 337–340  
**Haemoglobin F (fetal)**, 274, 282  
**Haemoglobin G<sup>Philadelphia</sup>**, 340  
**Haemoglobin H**, 281, 282, 333, 340  
**Haemoglobin H disease**, 281  
**Haemoglobin, measurement of**, 299–307  
**Haemoglobin S**, 283–284, 334–340  
**Haemoglobin S  $\beta$  thalassaemia**, 282, 283, 335  
**Haemoglobin SC disease**, 284  
**Haemoglobinopathies**, 283–285  
**Haemolysate for electrophoresis**, 340  
**Haemolysis, avoiding**, 299  
**Haemolytic anaemia**, 231–232, 276, 279–280  
**Haemolytic disease of newborn**, 364, 376–377  
**Haemolytic streptococci**, 159, 160, 162, 164  
**Haemolytic transfusion reaction**, 375–376  
**Haemolytic uraemic syndrome**, 105, 178  
**Haemophilia**, 341, 347  
***Haemophilus biogroup aegyptius***, 202, 203  
***Haemophilus ducreyi***, 91, 93, 204  
***Haemophilus influenzae***, 116, 124, 201–203  
***Haemophilus influenzae* antigen in csf**, 203  
***Haemophilus parainfluenzae***, 202, 204  
**Haemorrhage, acute**, 349  
**Haemorrhagic colitis**, 99, 105, 178, 179  
**Haemorrhagic fever viruses**, 28, 31–32  
**Hair, fungi of**, 235, 236, 237  
**Hand tally counter**, 314, 316  
**Hand washing**, 144, 145



- Hanging drop motility method**, 35  
**Hantaan virus**, 28  
**HAV**, see **Hepatitis A virus**  
**Hawksley microhaematocrit centrifuge**, 310, 311  
**Hazara virus**, 28  
**Hazardous pathogens**, 7, 8  
**HBs Ag tests**, 252  
**HBs solubility filtration test**, 336–337  
**HBV**, see **Hepatitis B virus**  
**hCG in urine**, 115  
**Health check for blood donors**, 353  
**Heat fixation of smears**, 37  
**Heated blood agar**, 386  
**Heinz bodies**, 285, 333  
**Helena BioSciences electrophoresis system**, 338–340  
**Helical viruses**, 26  
*Helicobacter pylori*, 197  
**Helper T lymphocytes**, 289  
**HemoCue system**, 299, 305  
**Heparin anticoagulant**, 297  
**Hepatitis**, 250–252  
**Hepatitis A virus (HAV)**, 29, 250, 251  
**Hepatitis B antigens**, 252  
**Hepatitis B surface antigen (HBs Ag)**, 252, 357  
**Hepatitis B virus (HBV)**, 27, 250, 251, 357  
**Hepatitis C virus (HCV)**, 28, 250, 252, 357  
**Hepatitis D virus (HDV)**, 30, 250, 251  
**Hepatitis E virus (HEV)**, 29, 250, 251  
**Hepatitis G virus (HGV)**, 28, 250  
**Hepatitis viruses**, 250–252  
**Hereditary spherocytosis**, 286, 328  
**Herpes zoster virus**, 30, 255  
**Herpesviruses**, 29–30  
**Heterophil antibodies**, 295  
**HIGH RISK pathogens**, 7, 8  
**Hikojima**, subtype of *V. cholerae*, 189  
**Hippurate hydrolysis test**, 163, 197  
*Histoplasma capsulatum*, 241  
*Histoplasma duboisii*, 241  
**Histoplasmosis**, 241  
**HIV**, 253–266  
**HIV/AIDS in Tropics**, 254, 256  
**HIV antibody tests**, 256, 258–263, 357  
**HIV ART**, 263–266  
**HIV Capillus test**, 261  
**HIV counselling (pre-, post-test)**, 258  
**HIV disease**, 254–256  
**HIV opportunistic pathogens**, 207, 235, 246, 255, 256  
**HIV tuberculosis association**, 71, 207, 255  
**HIV-1, HIV-2**, 253  
**Hodgkin's lymphoma**, 292  
**Hot air oven**, 53  
**Hot/cold Ziehl-Neelsen techniques**, 39–40  
**Howell Jolly bodies**, 329  
**HTLV-1, 11, viruses**, 29, 358  
**Human blood in blood agar**, 385  
**Human carriers**, 10–11  
**Human chorionic gonadotrophin (hCG)**, 115  
**Human immunodeficiency virus (HIV)**, 253–266  
**Human T cell lymphotropic virus (HTLV)**, 29, 292, 358  
**Humoral immunity**, 11–12  
**Hyaline casts**, 108, 109, 110  
**Hyaluronidase**, 12  
**Hybridoma**, 365  
**Hyditiform mole**, 115  
**Hydrocele fluid**, 85, 86  
**Hydrochloric acid, 1 mol/l**, 67, 395  
**Hydrogen sulphide production**, 102, 103, 180  
**Hygrosopic culture media**, 48  
**Hyper-reactive malarial splenomegaly**, 274, 292  
**Hypersegmented neutrophils**, 278, 327  
**Hyphae of fungi**, 32–33, 236, 238, 245  
**Hypochromic anaemia**, 277–278, 313, 327  
**IC tests**, see **Immunochromatographic tests**  
**Icosahedral viruses**, 26  
**IDL Tubex**, 186  
**Immobilization of *Vibrio* species**, 193–194  
**Immune antibodies**, 364, 369, 371, 376  
**Immune haemolytic anaemia**, 276, 280  
**Immune responses**, 11–13  
**Immunity**, 11  
**Immune responses**, 11–13  
**Immunoassays**, 14, 16, 17  
**Immunochromatographic tests**,  
   brucellosis, 200–201  
   chlamydia, 234  
   cholera, 191–192  
   D-dimer test, 346  
   dengue, 249  
   hepatitis, 252  
   HIV, 186  
   leptospirosis, 226  
   principle, 14–15  
   syphilis, 221–222  
   typhoid, 186  
**Immunocompetency**, 289  
**Immunoglobulins (Ig)**, 11, 12  
**Immunological (antigen) tests**, see **Antigen tests**  
**Immunosuppression**, 130, 253  
**Impedance cell analyzers**, 319  
**Improved Neubauer chamber**, 120, 314, 315  
**Improved Preston medium**, 196  
**Inaba subtype of *V. cholerae***, 189  
**Inclusion blenorrhoea**, 232  
**Inclusion bodies of *Chlamydia trachomatis***, 233  
**Inclusion conjunctivitis**, 232  
**Incoagulable blood**, 346  
**Incubation in carbon dioxide**, 61–62  
**Incubation of cultures**, 56, 59–62  
**Incubator**, 56, 59  
**Indeterminate leprosy**, 213  
**India ink preparation**, 121–122, 244  
**Indole reaction**, 67, 103, 180  
**Indole test**, 67–68  
**Induced sputum**, 246  
**Infantile gastroenteritis**, 178  
**Infection**, 3, 9–13, 15  
**Infectious diseases**, 1  
**Infectious mononucleosis**, 294–295  
**Infective endocarditis**, 125  
**Infertility**, 130  
**Inflammation**, 11  
**Inflammatory diarrhoeal disease**, 100  
**Influenza viruses**, 29  
**Innate immunity**, 11  
**Inoculation of culture media**, 54–56, 57  
**INR**, 344  
**Inspissation**, 54  
**Insulated container**, 360  
**Intermediate sensitivity pathogen**, 139, 141  
**Intermedius strain of *C. diphtheriae***, 167, 169  
**Intravascular haemolysis**, 274, 279, 280, 285, 375  
**Intrinsic system**, 341, 342  
**Invasiveness of bacteria**, 10  
**Iodine**  
   Albert's 44  
   Gram's (Lugol's), 38, 398  
   staining of *C. trachomatis*, 233

- Iridescence of *Haemophilus influenzae* b**, 203
- Iron deficiency anaemia**, 275–276, 309, 317
- Iron, serum**, 278, 281
- ISI**, 344
- Japanese encephalitis virus**, 31
- Jaundice**, 251, 279
- Joint (synovial) fluid**, 86
- Junin virus**, 31
- K antigens**, 102, 178
- Kanamycin blood agar**, 386
- Kaolin/platelet substitute**, 343
- Kaposi's sacroma**, 30
- Kauffmann-White system**, 184
- Kedani mite disease**, 228
- Kell blood group system**, 369
- Kerosene refrigerator**, 359
- KIA**, see **Kligler iron agar**
- Kidd blood group system**, 369
- Kirby-Bauer sensitivity testing**, 136, 137–142
- Klebsiella aerogenes***, 187
- Klebsiella granulomatis***, 44, 91, 92, 95
- Klebsiella pneumoniae***, 187
- Klebsiella rhinoscleromatis***, 187
- Kligler iron agar (KIA)**, preparation, 395, 396  
use of, 102, 103, 179, 180
- Koch steamer**, 49
- KOH (potassium hydroxide) preparation**, 236–238
- Kovac's indole reagent**, 68
- Kyasanur forest disease virus**, 27, 28
- L-arabinose fermentation**, 193
- L-forms**, 21–22
- Labelling**,  
of inoculated media, 56  
of slides, 36  
of specimens, 7
- Lactophenol cotton blue**, 242, 396
- Lactose egg yolk milk agar**, 172, 173, 174, 396
- Lactose fermenting enteric organisms**, 178, 180
- Lancefield grouping of streptococci**, 78, 159, 160, 162, 165
- Large lymphocytes**, 289, 326
- Lassa fever virus**, 27, 28, 31–32
- Late syphilis**, 218, 223
- Latent syphilis**, 218
- Lateral flow tests**, see **Immuno-chromatographic tests**
- Latex agglutination tests**, 14, 16, 17, 105, 158, 161, 176, 226, 261
- Lauryl sulphate broth**, 150
- Layered blood agar plates**, 386
- LCM virus**, see **Lymphocytic choriomeningitis virus**
- LDC test**, 68, 102, 103, 180, 182
- Lecithinase C activity**, 172
- Left shift of neutrophils**, 326
- Leg ulceration**, 80
- Legionella pneumophila***, 71
- Legionnaire's disease**, 71
- Leishman stain**, 322, 396–397
- Leishman staining of blood films**, 322–323
- Lepromatous leprosy (LL)**, 213
- Leprosy**, 212–216
- Leptocytes**, 328
- Leptospaeria senegalensis***, 239
- Leptospira biflexa***, 225
- Leptospira interrogans***, 225–227
- Leptospire**, 225
- Leptospirosis**, 225
- LeptoTek Dri Dot test**, 226
- LeptoTek lateral flow test**, 226
- Leptotrichia* species**, 205
- Leucocyte esterase in urine**, 112
- Leucocytosis**, 317
- Leucopenia**, 317
- Leucoerythroblastic blood picture**, 287
- Leukaemias**,  
acute lymphoblastic (ALL), 290, 291, 293  
acute myeloblastic (AML), 290, 291, 293  
chronic lymphocytic (CLL), 291, 293  
chronic myeloid (CML), 291, 293  
cytochemical staining, 291, 293  
hairy cell, 291, 293  
prolymphocytic, 291, 293
- Leukaemoid reaction**, 291, 293
- Leukocytosis (leucocytosis)**, 317
- Leukopenia (leucopenia)**, 317
- Levinthal agar**, 203, 397
- Lewis blood group system**, 369
- LGV** see **Lymphogranuloma venereum**
- Light chains of immunoglobulins**, 294
- Lincosamides**, 133, 134
- Lipase hydrolysis**, 172
- Liquoid**, 125, 390
- LISS**, 365, 372
- Listeria monocytogenes***, 170–171
- Listeriosis**, 170
- Litmus milk decolorization test**, 68–69
- Litmus milk medium**, 379
- Lock-jaw**, 174
- Loeffler (alkaline) methylene blue**,  
preparation, 397  
use of, 43
- Loeffler's polychrome methylene blue**, 166
- Loeffler serum agar**, 54, 168, 397–398
- Looping out**, 55
- Louse-borne relapsing fever**, 227
- Louse-borne typhus**, 229
- Lovibond comparator for testing chlorine**, 154–155
- Lovibond haemoglobin method**, 307
- Lowenstein Jensen medium**, 209
- Lower respiratory tract specimens**, 3
- Lugol's iodine**,  
preparation, 398  
use of, 38–39
- Lumbar puncture**, 116–117
- Lutheran blood group system**, 369
- Lyme disease**, 228
- Lymphoblast**, 291, 293
- Lymphocytes**,  
appearance, 289  
atypical (reactive), 327  
B lymphocytes, 12, 289–290  
CD<sup>4</sup> helper T lymphs, 12, 257–258, 289–290  
CD<sup>8</sup> cytotoxic T lymphs, 12, 289, 290  
functions, 289  
immunocompetency, 289  
large lymphs, 289, 326  
lymphocytosis, 325  
lymphopenia, 325  
NK cells, 11, 289  
production, 273, 289  
reactive (atypical), 327  
small lymphs, 289, 326  
T lymphocytes, 12, 254, 257, 289
- Lymphocytic choriomeningitis virus**, 116
- Lymphocytic meningitis**, 116
- Lymphocytosis**, 325
- Lymphogranuloma venereum (LGV)**, 90, 232
- Lymphoid cells**, 272, 273
- Lymphomas**, 292, 294
- Lymphopenia**, 325
- Lysine decarboxylase (LDC) test**, 68, 102, 103, 180, 182
- M protein**, 12, 294

- MacConkey agar**, 398  
**MacConkey broth (purple)**, 152–153  
**Macrocytes**, 309, 327  
**Macrocytic anaemia**, 278, 308, 313, 327  
**Macrolides**, 133, 134  
**Macrophages**, 11, 288–289  
**Macroscopical agglutination test in leptospirosis**, 226  
**Madura foot**, 239  
*Madurella grisea*, 239  
*Madurella mycetomatis*, 239  
**Mal del pinto**, 224  
**Malachite green stain**, 40, 398  
**Malaria**, 275, 284, 308, 327, 357  
**Malaria haemoglobinuria**, 278, 279  
*Malassezia furfur*, 238  
**Mannitol egg yolk phenol-red polymyxin agar**, 167  
**Mannitol salt agar culture**, 158, 398–399  
**Manufacturers addresses**, see **Appendix 11**  
**Marburg disease virus**, 27, 28, 31–32  
**Marginating pool of neutrophils**, 287  
*Mastalex MRSA*, 158  
**Mayaro virus**, 28  
**McFadyean reaction**, 43, 166  
**McFarland turbidity standard**, 137  
**MCH**, 277, 278, 313  
**MCHC**, 277, 278, 312–313  
**MCV**, 277, 278, 313  
**MDT for leprosy**, 216  
**Measles virus**, 29  
**Media**, see **Culture media**  
**Megaloblast**, 329  
**Megaloblastic anaemia**, 276, 278  
**Melioidosis**, 195  
**Membrane colony count**, 152  
**Membrane filters**, 49–50, 150, 195–196  
**Membrane filtration technique for testing water**, 149–152  
**Membrane lauryl sulphate broth**, 150  
**Meningitis**, 116, 119, 123, 124, 163, 174, 175, 178  
**Meningococcal meningitis**, 116, 118, 124, 175  
**Meningococcal septicaemia**, 175  
**Meningoencephalitis**, amoebic, 116, 122  
   anthrax, 166  
   trypanosomiasis, 122  
   viral, 124  
**Mesenteric lymphadenitis**, 199  
**Mesosomes**, 19  
**Messenger RNA**, 22  
**Metachromatic granules**, 168  
**Metamyelocyte**, 287  
**Methaemoglobin reduction test**, 333–334  
**Methanol, fixing blood films**, 321  
**Methicillin resistant *S. aureus* (MRSA)**, 65, 133, 158  
**Methylene blue, 0.4 mmol/l**, 334, 399  
**Methylene blue to detect faecal leucocytes**, 100  
**Methylene blue staining technique**, 43  
**Metronidazole**, 83, 133, 134, 206  
**MHC 1, 11, 12**  
**MI**, 216  
**MIC**, see **Minimum inhibition concentration**  
**Microaerophilic organisms**, 22, 59, 62  
**Microbial antigens**, see **Antigen tests**  
**Microbial diseases**, 23–25  
**Microbial flora**, 22–23, 62  
**Microbial resistance**, 134–135  
**Microbiological services**, 1–2  
**Microconidia**, 33  
**Microcytic anaemia**, 277–278, 308, 313, 327  
**Microhaematocrit centrifuge**, 310, 311  
**Microhaematocrit reader**, 310, 311  
**Microscopical examination of specimens**, 13, 35–45  
*Microsporium* species, 234, 235, 237  
**Midstream urine (MSU)**, 106  
**Miliary tuberculosis**, 207  
**Minimum bactericidal concentration (MBC)**, 136  
**Minimum inhibition concentration (MIC)**, 136  
**Mitis strain of *C. diphtheriae***, 167, 168  
**ML Flow test**, 214  
**MNS blood system**, 369  
**Modified New York City (MNYC) medium**, preparation, 399  
   use of, 94, 95, 177  
**Modified Tinsdale's medium (MTM)**, preparation, 399–400  
   use of, 78, 168  
**Molluscum contagiosum virus**, 29  
**Moniliasis**, 243  
**Monkeypox virus**, 29  
**Monoblast**, 288  
**Monoclonal antisera**, 365–366, 369  
**Monoclonal (M) Ig in myeloma**, 294  
**Monocytes**, appearance, 288, 326  
   functions, 288–289  
   monocytosis, 326  
   production, 273, 288  
**Monocytosis**, 326  
**Monosodium urate crystals**, 88  
**Monsur's medium**, 191  
*Moraxella catarrhalis*, 71, 204  
**Morbillivirus**, 29  
*Morganella morganii*, 189  
**Morphological index (MI)**, 216  
**Morphology of bacteria**, 19–22  
**Morula (Mott) cells**, 122  
**Mosaic fungus**, 236  
**Mosquito-borne infections**, 31  
**Motile bacteria**, 35–36, 100, 103, 170, 180, 190, 193–194  
**Motility of spermatozoa**, 131  
**Motility testing**, 35–36, 100–101, 103, 170, 180, 193–194  
**MOTT**, 210  
**Mott cells**, 122  
**Moulds**, 32–33  
**Mouth specimens, examination of**, 76–79  
**MRSA**, 65, 133, 158  
**MTM**, see **Modified Tinsdale's medium**  
**Mucormycosis**, 245–246  
**Mueller Hinton agar**, 137  
**Multibacillary leprosy**, 214  
**Multidrug therapy (MDT)**, 216  
**Multiple budding of *P. brasiliensis***, 242  
**Multiple myeloma**, see **Myelomatosis**  
**Multiple tube/MPN technique**, 149, 152–154  
**Multiplication of bacteria**, 22  
**Murine typhus**, 229  
**Mycelium**, 32  
**Mycetoma**, 81, 82, 217, 238–240  
*Mycobacterium africanum*, 207  
*Mycobacterium avium-intracellulare*, 211  
*Mycobacterium bovis*, 207  
*Mycobacterium chelonae*, 211  
*Mycobacterium fortuitum*, 211  
*Mycobacterium kansasii*, 211  
*Mycobacterium leprae*, 212–216  
*Mycobacterium malmoense*, 211  
*Mycobacterium scrofulaceum*, 211  
*Mycobacterium tuberculosis*, acid fastness, 39  
   antibodies, 209  
   antimicrobial susceptibility, 76, 210

- complex, 207  
 concentration technique, 73, 208  
 culture of, 76, 209  
 drug resistance, 210  
*FASTplaque TB* phage test 210  
 fixation of smears, 40  
 fluorescence microscopy, 209  
 HIV association, 71, 207, 255, 256  
 identification of, 209  
 in cerebrospinal fluid, 121, 124, 207  
 in sputum, 71, 73, 207, 208  
 in urine, 105, 107  
 microscopy, 39–41, 72–73  
 pathogenicity, 71, 207  
 pigment production, 209, 211  
 specimens, 71–72  
 transmission, 207  
 Ziehl-Neelsen staining, 39–41, 73, 208–209
- Mycobacterium tuberculosis* complex**, 207  
***Mycobacterium ulcerans***, 39–41, 211–212  
***Mycobacterium xenopi***, 211  
**Mycology**, 8, 32–35, 234–247  
***Mycoplasma pneumoniae***, 21  
**Mycoses**, 33–34  
**Mycotoxicoses**, 33–34  
**Myeloblast**, 286, 291  
**Myelocyte**, 287  
**Myelofibrosis**, 287  
**Myeloid cells, production**, 272, 273  
**Myelomatosis**, 294  
**Myonecrosis**, 171  
**Mylar-backed cellulose acetate membranes**, 337–338
- Naegleria amoebae***, 122  
**Nagler reaction**, 172–173  
**Nail fungi**, 234, 235, 236  
**Nasopharyngeal aspirate**, 205  
**Natural killer cells**, 11, 289  
**Natural immunity**, 11  
**NCCLS chart**, 141–142  
**Necrotizing enterocolitis**, 171  
**Needlestick injury**, 9  
***Neisseria gonorrhoeae***, 90, 91–92, 94, 95, 176–179  
***Neisseria meningitidis***, 116, 124, 175–176  
**Neomycin blood agar**, 162, 172, 386  
**Neonatal conjunctivitis**, 176  
**Neonatal jaundice**, 285, 349  
**Neonatal meningitis**, 162, 170, 178  
**Neonatal ophthalmia**, 232  
**Neonatal septicaemia**, 127  
**Neonatal tetanus**, 174  
***Neo-Sensitabs***, 137  
**Neurosyphilis**, 218, 222  
**Neurotoxin**, 173, 174  
**Neutral red stain**,  
   preparation, 400  
   use of, 38–39  
**Neutropenia**, 325  
**Neutrophilia**, 325  
**Neutrophils**,  
   appearance, 287, 326  
   circulatory pool, 287  
   functions, 287  
   granules, 287  
   hypersegmented, 278, 327  
   left shift, 326  
   marginating pool, 287  
   neutropenia, 287, 325  
   neutrophilia, 287, 325  
   phagocytosis, 287  
   production, 273  
   toxic granulation, 287, 326  
**New methylene blue**, 331, 400  
**Nichrome wire loop**, 55  
**Nitrate broth**, 400  
**Nitrite in urine**, 112  
**Nitrite reducing bacteria**, 112  
**Nitrocefin test**, 142  
**Njovera**, 224  
**NNRTIs**, 264  
***Nocardia asteroides***, 216  
***Nocardia brasiliensis***, 216, 217, 239  
***Nocardia* species**, 216–217  
**Nonchromogen**, 209, 210, 211  
**Non-gonococcal urethritis**, 90, 94, 233  
**Non-lactose fermenting enterobacteria**, 178, 180  
**Non-specific immunity**, 11  
**Normal microbial flora**, 22–23, 62  
**Normochromic anaemia**, 278–279  
**Norwalk agent**, 29  
**NsRTIs**, 264  
**NtRTIs**, 264  
**Nucleated red cells**, 279, 316, 328  
**Nucleic acid tests**, 18  
**Nutrient agar**,  
   preparation, 400  
   use of, 50  
**Nutrient broth**, 401  
**p-Nitro-benzoic acid (PNB)**, 209
- O agglutinin titres**, 185  
**O antigens**, 102, 178, 182  
**Ocular chlamydial infection**, 232  
**Ogawa *V. cholerae* subtype**, 189, 191  
**O, H titres in Widal test**, 185  
***Onchocerca volvulus* microfilariae in urine**, 110  
**Oncogenes**, 290  
**Oncogenic viruses**, 26  
**ONPG**, 176, 177, 180  
**Onyalai**, 318  
**O'nyong-nyong virus**, 28  
**Ophthalmia neonatorum**, 90, 176  
**Opportunistic pathogens**, 23, 27, 33, 34, 211  
**Opsonin**, 11  
**Optochin sensitivity**, 164  
**Orf virus**, 29  
***Orientia tsutsugamushi***, 25, 229  
***Ornithodoros* ticks**, 227  
**Oropouche virus**, 28  
**Oroya fever**, 231  
**Orthomyxovirus**, 29  
**Orthopox viruses**, 29  
**Ovalocytosis**, 286  
**OX19, OXK, OK2 *Proteus* strains**, 188, 230  
**Oxacillin disc**, 141, 164  
**Ox-gall medium**, 183  
**Oxidant drugs (associated with G6PD deficiency)**, 285  
**Oxidase activity**, 69, 95, 103, 175, 180  
**Oxidase reagent**, 70, 401  
**Oxidase reagent strips**, 70  
**Oxidase test**, 69–70  
**Oxygen dissociation (haemoglobin)**, 274
- P blood group system**, 369  
**Packed cell volume (PCV)**, 248, 309–312  
**Packed red cells for transfusion**, 349, 375  
**Paired sera**, 15  
**Panagglutination**, 374  
***PanBio Dengue Duo IgM/IgG* test**, 249  
**Pancreatin mucolytic reagent**, 401  
**Pandemic**, 9  
**Pandy's test**, 121  
**Papillomavirus**, 30  
**Papovaviruses**, 30  
***Paracoccidioides brasiliensis***, 242  
**Paracoccidioidomycosis**, 242  
***Paragonimus* eggs, in sputum**, 74  
**Parainfluenza viruses**, 29  
**Paramyxovirus**, 29  
**Parapox viruses**, 29  
**Paraproteinaemia**, 294  
**Paratyphoid**, 182–183, 185  
**Partial antigen D variants**, 364  
**Parvovirus B<sub>19</sub>**, 30, 275, 286  
**Passive immunity**, 12

- Pasteur pipette, making of**, 58  
**Pastorex Staph Plus test**, 158  
**PATH immunodiagnosics**, 15  
**Pathogenic microorganisms**, 23–25  
**Paucibacillary leprosy**, 213, 214  
**PCR (polymerase chain reaction)**, 18  
**Pediculus lice**, 227  
**Pelvic inflammatory disease**, 90, 176  
**Pencil cells**, 328  
**Penicillin bromocresol purple reagent**, 391  
**Penicillin resistance**, 133, 135  
**Penicillinase**, 133, 138, 177  
**Penicillins**, 133  
**Penicilliosis**, 245  
**Penicillium marneffei**, 245  
**Peptone water**, 190, 401  
**Peptone water, alkaline**, 47, 19, 190, 384  
**Peptone water sugars**, 401–402  
**Peptostreptococcus species**, 85, 165  
**Performance testing of culture media**, 50  
**Pericardial fluid**, 85, 86  
**Pericarditis**, 86, 256  
**Peritoneal fluid**, see **Ascitic fluid**  
**Petri dishes**, 53, 55–56, 57, 150  
**Peurperal sepsis**, 90  
**pH**,  
   of faeces, 99, 181  
   of culture media, 49  
   of vaginal discharge, 92  
**Phage test to detect TB**, 73–74  
**Phagocyte**, 11, 12  
**Phagocytosis**, 11, 12, 287, 288  
**Pharyngitis (sore throat)**, 76, 159  
**Phase 1 and 2 antigens**, 185  
**Phenylalanine test (PDA)**, 188, 189  
**Phialophora species**, 238  
**Philadelphia chromosome**, 291  
**Phorphyromonas species**, 205, 206  
**Phosphate buffer-saponin**, 336, 402  
**Phosphate buffer water**, 387–388  
**Phosphate buffered saline**, 402–403  
**Phospholipase C**, 171  
**Photochromogen**, 210, 211  
**Physiological saline**, 402  
**Pian**, 224  
**Picornaviruses**, 29  
**PID**, 70, 176  
**Pigbel**, 98, 171  
**Pigment produced by**  
   *P. aeruginosa*, 194  
**Pili (fimbriae)**, 12  
**'Pink-eye'**, 203  
**Pinta**, 224–225  
**Pipetting accurately**, 302  
**Pityriasis versicolor**, 238  
**Plague**, 197–198  
**Plague dipstick**, 199  
**Plasma cells**, 11, 294  
**Plasma used in coagulase test**, 65–66  
**Plasmids**, 19, 135, 177, 178, 179  
**Plasmin**, 346  
**Platelet count**, 317–319, 346  
**Platelets**,  
   count, 317–319  
   function, 271, 341  
   haemocytometer, 318  
   production, 273  
   thrombocytopenia, 249, **318**, 341, 347  
   thrombocytosis, **319**  
**Plating out**, 55–56, 57  
**Pleural effusion (fluid)**, 85, 86  
**Pneumococcal antigen**, 164  
**Pneumococci**, see **Streptococcus pneumoniae**  
*Pneumocystis carinii*, see *Pneumocystis jiroveci*  
*Pneumocystis jiroveci*, 71, 246–247  
**Pneumocystis cysts**, 247  
*Pneumocystis pneumonia*, 246  
**Pneumoenteritis**, 195  
**Pneumonia**, 71, 72, 163, 256  
**Pneumonic plague**, 74, 198  
**Pneumothorax**, 86  
**Poikilocytosis**, 328  
**Poliomyelitis**, 31  
**Polioviruses**, 29  
**Pollution of water supplies**, 143, 146  
**Polychromasia**, 277, 279, 327  
**Polychrome Loeffler methylene blue**, 43, 83  
**Polycythaemia**, 286  
**Polymorphonuclear neutrophil**, see **Neutrophils**  
**Polymyxin B sensitivity test**, 191  
**Post-analytical stage**,  
   haematology tests, 271  
   microbiological tests, 5  
**Post-partum haemorrhage**, 349  
**Post-streptococcal diseases**, 161  
**Potassium hydroxide (KOH)**  
   preparation, 74, 235–236, 403  
**Potassium hydroxide reagent**, 235  
**Potassium permanganate fixative**, 41–42, 166, 403  
**Potassium tellurite**, 404  
**Pouring plates (dispensing agar)**, 53–54  
**Power supply for electrophoresis**, 338  
**Poxviruses**, 29  
**PPNG**, 177  
**Practice of microbiology at district level**, 1–2, 8  
**Pre-analytical stage**,  
   haematology tests, 269–270  
   microbiological tests, 3–4  
**Pregnancy testing**, 115  
**Preparation of culture media**, 48–49  
**Preservation of control strains**, 51  
**Preston blood-free medium**, 196  
**Presumptive E. coli count**, 149  
*Prevotella species*, 206  
**Primary amoebic meningoencephalitis**, 122, 124  
**Primary dengue**, 248, 249  
**Primary syphilis**, 218, 223  
**Primary tuberculosis**, 207  
**Prions**, 21  
**Probability tables for estimating faecal coliforms**, 153–154  
**Promonocyte**, 288  
**Promyelocyte**, 286  
**Pronormoblast**, 273  
**Propane gas**, 359  
**Protease inhibitors (PIs)**, 264  
**Protein**,  
   in csf, 121, 124  
   in effusions, 87–88  
   in urine, 112  
**Proteinase activity**, 172  
**Proteinuria**, 112  
**Proteolytic reaction**, 172  
*Proteus mirabilis*, 180, 188–189  
**Proteus strains, OX19, OXK, OX2**, 188, 230  
*Proteus vulgaris*, 189  
**Prothrombin time**, 344–345, 346  
**Protoplast**, 22  
*Providencia species*, 189  
**Prozone reaction**, 15, 201, 225  
*Pseudallescheria boydii*, 239  
**Pseudogout**, 88  
**Pseudohyphae**, 32, 244  
*Pseudomonas aeruginosa*, 194  
*Pseudomonas fluorescens*, 194–195  
*Pseudomonas pseudomallei*, see *Burkholderia pseudomallei*  
*Pseudomonas putida*, 194–195  
**Puerperal sepsis**, 94  
**Pulmonary anthrax**, 166  
**Pulmonary tuberculosis**, 207

- Purulent effusion**, 87, 89
- Pus**,  
collection, 81–82  
examination, 80–85  
pathogens, 80–81
- Pus cells**,  
containing diplococci, 94  
in csf, 117, 118, 123  
in faeces, 100, 181  
in urine, 108, 109
- Pyelonephritis**, 105
- Pyocyanin pigment production**, 194
- Pyogenic (purulent) meningitis**, 116, 124, 175
- Pyuria**, 105, 108
- Q fever**, 230–231
- Quality assurance**,  
blood transfusion, 350–351  
culture media, 50–51  
haematology, 268–271  
microbiology, 2–5, 50–52, 140  
sensitivity tests, 140
- Quinolones**, 133, 134, 141
- Rabies virus**, 29
- Rapid carbohydrate utilization test**, 168–169
- Rapid litmus milk reduction test**, 68–69
- Rapid plasma reagin (RPR) card test**, 220, 223
- Reactive (atypical) lymphocytes**, 327
- Reader for PCV**, 310, 311
- Reagents**, see **Appendix 1**
- Reagin (cardiolipin) tests**, 219, 220–221
- Rectal swab**, 98–99
- Red cells**,  
composition, 274  
disorders, 274–286  
hypochromic, 313, 327  
indices, 312–313  
macrocytic, 278, 308, 313, 327  
microcytic, 313, 327  
morphology in blood films, 324–325, 327–329  
production, 272–274  
sickle, 283, 328, 334–337
- Red cells in urine (haematuria)**, 108, 109
- Red Cross/Red Crescent Societies**, 349
- Reducing agents in culture media**, 60–61
- Reed-Sternberg (RS) cells**, 292
- Reference ranges**,  
ESR, 331  
haemoglobin, 307  
MCHC, 312  
MCV, 313  
PCV, 312  
platelets, 318–319  
reticulocytes, 332  
WBC differential count, 325  
WBC total count, 317
- Reiter's syndrome**, 86
- Relapsing fever**, 227–228
- Renal tuberculosis**, 207
- Reoviruses**, 29
- Reporting tests**,  
haematological, 271  
microbiological, 5
- Reproduction of bacteria**, 22
- Resistant pathogen**, 138, 141
- Reticulin**, 331
- Reticulocyte count**, 331–333
- Reticulocytes**,  
appearance, 277, 284  
counting, 331–333  
polychromasia, 277, 279  
production, 273  
response in anaemia, 232, 277, 332  
reticulocytosis, 332  
staining, 331–332  
thick blood film (HbSS), 284
- Reticuloendothelial (RE) system**, 288
- Retrovirus**, 29
- Request forms**,  
blood transfusion, 370  
haematological, 270  
microbiological, 4
- Resazurin**, 60
- Residual chlorine**, 154–155
- Resistance of bacteria to antimicrobials**, see **Drug resistance**
- Rhabdoviruses**, 29
- Rhesus antibodies**, 364
- Rhesus antigens**, 363–364
- Rhesus blood group system**, 363–364
- Rhesus HDN**, 364, 377–378
- Rheumatic fever**, 159, 161
- Rheumatic heart disease**, 159
- Rhinoscleroma**, 187
- Rhinosporidiosis**, 240
- Rhinosporidium seeberi**, 240
- Rhizomucor species**, 245
- Rhizopus species**, 245
- Ribosomal RNA of reticulocytes**, 331
- Rice water stools**, 190
- Rickettsia species**, 21, 228–230
- Rickettsialpox**, 229
- Rifampicin**, 134, 210, 216, 264
- Rift Valley fever virus**, 28
- Ringworm fungi**, 234–238
- RNA viruses**, 28–29
- Robertson cooked meat medium**, 172, 174, 175
- Rocio virus**, 28
- Rods (bacilli)**, 19–20
- Rosco products**,  
antimicrobial testing tablets, 137  
diagnostic tablets, 63  
*Neo-Sensitabs*, 137
- Rotators**, 220
- Rotaviruses**, 29
- Rouleaux of red cells**,  
in blood grouping, 368  
in myeloma, 294, 328
- Routes of infection**, 10, 26–27
- Rowanowsky stain**, 321–322
- RPR card test**, 220, 223
- Rubella virus**, 28
- Saccharolytic reaction**, 172
- Safe working practices**, 8–9, 27
- Safety in microbiology**, 8–9
- Sahli acid haematin method**, 307
- Saline**, see **Sodium chloride**, 8.5 g/l
- Saline preparation**,  
for faecal parasites, 100  
for *Paragonimus*, 74  
of vaginal discharge, 92
- Salmonella antigen suspensions**, 185
- Salmonella antisera**, 185
- Salmonella enterica**, 182
- Salmonella Enteritidis**, 183
- Salmonella food-poisoning (enterocolitis)**, 183
- Salmonella Paratyphi A, B, C**, 103, 182, 183, 184, 185
- Salmonella Shigella (SS) agar**, 181
- Salmonella serovars**, 103, 125, 180, 182–186
- Salmonella Typhi**, 103, 125, 180, 182–183, 185–186
- Salmonella Typhimurium**, 183, 184
- Sampling (water) techniques**, 147–149
- Sandfly fever viruses**, 28
- Sanitation related diseases**, 143–145
- Saponin phosphate buffer**, 336, 402
- SARS**, 29, 31
- Satellitism test**, 202
- Scalp fungi**, 234, 236–237

- Scarlet fever, 159  
 Schistocytes, 279–280, 328  
*Schistosoma* eggs in urine, 109, 110  
 Sclerotic cells, 238  
 Scotochromogen, 210  
 Scrub typhus, 228, 229  
*SD Bioline HIV 1/2* test, 262  
 Sd i, 181, 182  
 Sealant for capillaries, 310  
 Secondary dengue, 248, 249  
 Secondary syphilis, 218, 223  
 Selective media, 46  
 Self antigen reacting lymphocytes, 289  
 Semen, examination, 130–132  
 Seminal fluid, see Semen  
 Semisolid culture media, 47, 401  
 Sensitivity (susceptibility) discs, 136, 137  
 Sensitivity of assays, 18, 260  
 Sensitivity (susceptibility) testing, 134–142  
 Sensitized cells (D), 371  
 Septic abortion, 94  
 Septicaemia, 124–125  
 Septicaemic plague, 198  
 Sequestrene, see EDTA  
 Seroconversion (HIV), 255  
 Serological tests, 17–18  
*Serratia marcescens*, 180, 188  
 Serum for antibody testing, 17  
 Serum hepatitis, see Hepatitis B  
 Sexually transmitted infections (STI),  
   chancroid, 93, 204, 218  
   *Chlamydia* infection, 231–234  
   donovanosis, 91, 95  
   *Gardnerella* infection, 91, 94  
   gonorrhoea, 90, 176  
   hepatitis B, 250  
   HIV, 253–254, 257  
   laboratory diagnosis, 93  
   lymphogranuloma venereum (LGV), 90, 232  
   syphilis, 218–219  
   trichomoniasis, 92, 94–95  
*Shigella* antisera, 182  
*Shigella boydii*, 103, 179, 181, 182  
*Shigella dysenteriae*, 103, 179, 181, 182  
*Shigella flexneri*, 103, 179, 181, 183  
*Shigella sonnei*, 103, 179, 181, 182  
*Shigella* species, 97, 103, 179–182  
 Shigellosis, 97, 181  
 Shingles, 30  
 Sickle cell anaemia, 284, 336, 337  
 Sickle cell disease, 284, 334–337  
 Sickle cell slide test, 284, 335–336  
 Sickle cell solubility filtration test, 284, 336–337  
 Sickle cell trait, 284, 335, 337  
 Sickle cells, 283, 328, 335  
 Simmons citrate agar, 65  
 Sindbis virus, 28  
 Siti, 224  
 Skin,  
   *B. anthracis*, 166  
   *C. diphtheriae*, 167  
   fungi, 234, 235–236  
   *M. leprae*, 212–216  
   *M. ulcerans*, 211–212  
   specimens, examination of, 80–85  
 Skin diphtheria, 167  
 Skin smears in leprosy, 214–216  
 SLE, 295  
 Slide coagulase test, 66  
 Slopes of media, 56, 57  
 Small lymphocytes, 289, 326  
 Smallpox virus, 29  
 Smear cells in CLL, 293  
 Smears, preparation of,  
   bacterial, 36  
   blood, 319–321  
 Snake bite causing bleeding, 347  
 Sodium bicarbonate-formalin diluting fluid, 132, 403  
 Sodium chloride, 8.5 g/l (physiological saline), 402  
 Sodium citrate anticoagulant, 297, 330, 403  
 Sodium deoxycholate reagent, 63, 403  
 Sodium dithionite reagent, 335, 336  
 Sodium hydroxide reagents, 404  
 Sodium metabisulphite reagent, 335  
 Sodium nitrite-glucose reagent, 333, 404  
 Sodium polyanethol sulphonate (SPS), 125, 390  
 Sodium thioglycollate, 60  
 Soft sore, 91, 93, 204  
 Solid culture media, 47  
 Solubility bile test, 63–64, 164  
 Solubility test to detect HbS, 284, 336–337  
 Somatic antigens, 102, 178, 182  
 SOPs,  
   blood transfusion, 350–351  
   haematology, 268–271  
   microbiology, 2–5  
 Sorbitol MacConkey agar, preparation, 404  
   use of, 101, 105, 179  
 Sore throat, 159  
 Specific immunity, 11–12  
 Specificity of assays, 18, 260  
 Specimens,  
   blood specimens, 269–270  
   HIGH RISK, 7, 8  
   microbiological, 3, 4, 6–8  
   transporting, 7–8  
 Sperm count, 131–132  
 Spermatozoa,  
   abnormalities, 132  
   in urine, 109, 111  
   morphology, 132  
   motility, 132  
   pH, 137  
   sperm count, 131–132  
   volume, 131  
 Spherocytes, 279, 286, 328  
 Spheroplast, 22  
 Spherule (*C. immitis*), 243  
 Spinal fluid, see Cerebrospinal fluid  
*Spirillum minus*, 21  
 Spirochaetes, 21, 95, 219  
 Spores,  
   bacterial, 19, 166, 173, 174  
   fungal, 33  
*Sporothrix schenckii*, 240–241  
 Sporotrichosis, 240–241  
 Spotted fever, 229, 230  
 Spreader for blood films, 320  
 SPS, 125, 390  
*Sputolysin*, 74  
 Sputum,  
   collection, 71–72  
   examination, 71–76  
   pathogens, 71  
 SS (*Salmonella-Shigella*) agar, 181  
 Stab cell, 287  
 Stab media, 56, 57  
 Stability, EDTA blood, 298–299  
 Staining blood films, 320–323  
 Staining smears,  
   bacterial, 37–45  
   blood, 270, 320–323  
 Stains, see Appendix 1  
 Standard crossmatch, 371–373, 374  
 Standard operating procedures, see SOPs  
*Staphylococcus aureus*, 64, 65–67, 138, 157–158  
*Staphylococcus epidermidis*, 158  
*Staphylococcus saprophyticus*, 158  
 Starch utilization, 168–169  
 STD, see Sexually transmitted infections  
 Steaming, 49  
 Steel wool, 60

- Stem cells**, 272, 273  
**Sterile sites**, 23, 62  
**Sterile technique**, 54–55  
**Sterility testing of culture media**, 50  
**Sterilization**,  
autoclaving, 49  
filtration, 49–50  
flaming, 54  
hot air oven, 53  
steaming, 49  
**Sterilizing glassware**, 53  
**Stock buffer solutions**, 387–388  
**Stock control cultures**, 50  
**Stokes sensitivity testing technique**, 136–137  
**Stool specimens**, see **Faecal specimens**  
**Stops for dark-field**, 36, 95  
**Storage**,  
control cultures, 51, 52  
culture media, 51, 53  
**Storage of donor blood**, 359–360  
**Streptococcal glomerulonephritis**, 161  
**Streptococcal grouping kits**, 160  
***Streptococcus agalactiae* (Group B)**, 162–163  
***Streptococcus pneumoniae***, 63–64, 116, 124, 163–164  
***Streptococcus pyogenes* (Group A)**, 77, 78, 79, 159–162  
***Streptococcus suis***, 116, 124  
**Streptolysin O**, 161  
***Streptomyces somaliensis***, 217, 239  
**Structure of bacteria**, 19–22  
**Stuart's transport medium**, 7  
**Subarachnoid haemorrhage**, 117  
**Subculturing blood culture broth**, 128  
**Subcutaneous mycoses**, 33, 34  
**Subcutaneous zygomycosis**, 240  
**Sucrose fermentation of *Vibrio* species**, 192  
**Sulphonamide crystals in urine**, 111  
**Sulphonamides**, 133, 134  
**'Sulphur' granules**, 217  
**Superficial mycoses**, 33, 34  
**Supravital staining**, 331  
**Susceptibility testing**, 134–142  
**Susceptible pathogen**, 139, 141  
**Swarming of *Proteus***, 188  
**Swinnex type filter**, 49–50  
**Symbionts**, 22–23  
**Symmetry of viruses**, 26  
**Synovial (joint) fluid**, 86  
**Syphilis**, 91, 95, 124  
**Syphilis IC tests**, 221–222  
**Syphilis tests**, 219–223  
**Syphilitic meningitis**, 124  
**Syphilitic meningitis**, 124  
**Systemic lupus erythematosus (SLE)**, 295  
**Systemic mycoses**, 33, 34  
**T cell leukaemia**, 29  
**T lymphocytes**, 11, 12, 254, 257, 289  
**Tally counter**, 315  
**Target cells**, 280, 284, 328  
**TBA**, see **Tellurite blood agar**  
**TCBS**, see **Thiosulphate citrate-bile salt sucrose agar**  
**Tear drop cells**, 328  
**Tellurite blood agar (TBA)**,  
preparation, 404  
use of, 78, 168  
**Temperature**,  
blood bank, 359, 361  
incubating bacteria, 56  
**Tetanus**, 174  
**Tetracyclines**, 133, 134  
**Thalassaemia intermedia**, 280, 282  
**Thalassaemia major**, 280, 282  
**Thalassaemia minor**, 280, 282  
**Thalassaemia syndromes**,  
*alpha*, 280, 281, 282  
*beta*, 280, 281, 282  
haemoglobin Bart's hydrops syndrome, 281, 282  
haemoglobin H disease, 281  
intermedia, 280, 282  
major, 280, 282  
minor, 280, 282  
**Thayer Martin medium**,  
preparation, 404–405  
use of, 94, 95, 177  
**Thermotolerant coliforms**, 146  
**Thin blood films**, 319–329  
**Thioglycollate broth**,  
preparation, 405  
use of, 60, 83, 126, 128  
**Thiosulphate citrate bile-salt sucrose (TCBS) agar**,  
preparation, 405  
use of, 101, 102, 190–191, 193  
**Throat diphtheria**, 167  
**Throat, mouth specimens, examination of**, 76–79, 161, 168  
**Transfusion**, see **Blood transfusion**  
**Transfusion reaction**,  
action to take, 376  
bacteriological investigation, 130  
causes, 375–376  
**Transfusion records**, 373  
**Transfusion transmitted infections**, 353, 357–358  
**Transmission of microbial diseases**, 10  
**Transport media**,  
alkaline peptone water, 190, 384  
Amies medium, 7, 91, 92, 384  
Cary-Blair, 7, 388–389  
control of, 7, 51  
glycerol saline, 394–395  
**Transport of microbiological specimens**, 7–8  
**Transporting blood**, 360–361  
**Transudate**, 85, 88  
**Travellers diarrhoea**, 178  
***Treponema carateum***, 224–225  
***Treponema endemicum***, 224  
***Treponema pallidum***, 91, 92, 95, 218–224, 357  
***Treponema pallidum haemagglutination (TPHA) test***, 221, 223  
***Treponema pertenue***, 224  
**Treponemal tests**, 219–222  
***Trichomonas vaginalis***, 45, 94–95, 109, 110  
**Trichomoniasis**, 92, 94–95  
**Trichophyton species**, 235, 238  
**Trimethoprim**, 133, 134, 141  
**Triple phosphate crystals**, 111  
**Tris-EDTA borate buffer**, 406  
**TRNG**, 177  
**'Tropical arthritis'**, 86  
**Tropical spastic paraparesis (TSP)**, 292  
**Tropical ulcer**, 228  
***Trypanosoma cruzi* in donor blood**, 357–358  
**Trypanosomes in c.s.f.**, 117, 122  
**Trypanosomiasis meningoencephalitis**, 122, 124  
**Tryptone soya agar**, 200  
**Tryptone soya diphasic medium**, 126, 200  
**Tryptone water**, 68  
**Tryptophan breakdown**, 67  
**Tryptose agar**, 170  
**Tube coagulase test**, 66–67  
**Tubercle bacillus**, see ***Mycobacterium tuberculosis***  
**Tuberculoid leprosy (TT)**, 213  
**Tuberculosis**, 207, 255, 256  
**Tuberculous meningitis**, 121, 124, 207  
**Turbidity standard**, 137  
**Turbidity tube**, 155  
**Turbidity units (TU)**, 155  
***TYPHI rapid IgM test***, 186



- Typhoid**, 182, 185–186  
**Typhoid carriers**, 182  
**Typhoid fever IgM tests**, 186  
**Typhus**, 228, 229  
**Tyrosine crystals**, 111
- Ulcer material**,  
 collection, 81–82, 212  
 examination, 80–84  
 pathogens, 80–81, 212
- Unchlorinated water supplies**,  
 152
- Undulant fever**, 199  
**Uni-Gold HIV test**, 261–262  
**Untreated water samples**, 152
- Urea broth**, 70  
**Urease breath test**, 197  
**Urease enzyme activity**, 169, 180,  
 188, 189, 197  
**Urease test**, 70  
**Urethral specimens**,  
 collection, 91–92  
 examination, 90–97  
 pathogens, 90–91  
**Urethral swab**, 90, 91–92  
**Urethritis**, 90  
**Uric acid crystals**, 111  
**Urinary schistosomiasis**, 109,  
 110  
**Urinary tract infection**, 105, 178,  
 188
- Urine**,  
 AFB in, 107  
 antimicrobial sensitivity testing,  
 113  
 appearance, 107  
 bacterial count, 105, 113  
 boric acid preservation, 106  
 casts, 108–110  
 collection of, 106–107  
 crystals, 111  
 culture, 112–113  
 dipslides, 106–107  
*E. coli*, 178  
 epithelial cells, 109, 110  
 Greiss test, 112  
 Gram smear, 111–112  
 hCG, 115  
 leucocyte esterase, 112  
 microscopy, 107–112  
*M. tuberculosis*, 105, 107  
*N. gonorrhoeae*, 92, 112  
 nitrite, 112  
 pathogens in, 105, 112, 178, 188  
 pregnancy test, 115  
 protein, 112  
 pus cells, 108, 109  
 red cells, 108, 109  
*Schistosoma* eggs, 109, 110  
 spermatozoa, 109, 111  
 strip tests, 112  
 transport of, 106  
*T. vaginalis*, 107, 110  
*W. bancrofti*, 110  
 yeasts in, 109, 110
- Urogenital specimens**,  
 collection, 91–93  
 examination, 90–97  
 pathogens, 90–91
- Urticaria**, 375  
**UTI**, 105
- Vaccinations**, 12, 176  
**Vaginal candidiasis**, 91, 92  
**Vaginal discharge**, see **Vaginal specimens**  
**Vaginal specimens**,  
 collection, 92  
 examination, 94–95  
 pathogens, 90, 91, 243
- Vaginitis**, 91, 92, 243  
**Vaginosis**, 91, 92, 94  
**Valine substitution**, 283  
**Vancomycin**, 134, 141  
**Varicella-zoster virus**, 30  
**Vascular endothelial damage**, 341  
**VDRL test**, 220, 222, 223  
**Vectors of pathogens**, 13  
**Venepuncture**,  
 for blood tests, 297–298  
 for collecting donor blood,  
 355
- Venereal diseases**, see **Sexually transmitted infections**  
**Venous blood, collection**, 297–298  
**Vero-toxin producing *E. coli*, 0157**, 98, 105  
**VHF**, see **Viral haemorrhagic fever viruses**  
**Vi antigen**, 102, 178  
***Vibrio alginolyticus***, 192, 193  
***Vibrio cholerae*, 01, 0139**, 98, 99,  
 101, 189–192, 384  
***Vibrio cholerae* antisera**, 191  
***Vibrio cholerae* dipstick**, 191–192  
***Vibrio fluvialis***, 192, 193  
***Vibrio mimicus***, 192, 193  
***Vibrio parahaemolyticus***, 192,  
 193  
***Vibrio vulnificus***, 192, 193  
**Vincent's angina**, 228  
**Vincent's organisms**, 76, 78, 82  
**Viper envenomation**, 347  
**Viral haemorrhagic fever (VHF) viruses**, 28, 31–32  
**Viral hepatitis**, 250–252  
**Viral meningitis**, 124  
**Viridans streptococci**, 164  
**Virology**, 8  
**Virulence**, 9, 13, 166, 169
- Viruses**,  
 arboviruses, 31–32  
 capsid symmetry, 26  
 characteristics of, 25–32  
 classification, 26, 28–30  
 dengue viruses, 248–250  
 DNA viruses, 29–30  
 effect of heat and chemicals,  
 27–28  
 Epstein Barr virus (EBV), 292  
 haemorrhagic fever viruses, 28,  
 31–32  
 hepatitis viruses, 250–252  
 HIGH RISK viruses, 27  
 HIV-1, -2, 253–266  
 pathogenicity, 26, 30–32  
 reproduction, 25–26  
 RNA viruses, 28–29  
 structure, 26  
 transmission, 26–27  
 tropical countries, 30–31  
 VHF viruses, 28, 31–32  
 viral meningitis, 124
- Visitect Syphilis test**, 221–222  
**Vitamin B<sub>12</sub> deficiency**, 276, 278  
**Voges-Proskauer (V-P) reaction**,  
 180, 191  
**Volutin granules**, 44, 168  
**VTEC**, see **Vero-toxin producing *E. coli***
- Wagtech water testing kit**, 152  
**Waldenström's macroglobulinaemia**, 294  
**Warfarin monitoring**, 344–345
- Water**,  
 bacteriological testing, 149–154  
 chlorine test, 154–155  
 coliform count, 146, 149–154  
 membrane filtration, 149–152  
 multiple tube technique,  
 152–154  
 sampling of, 147–149  
 surveillance, 144  
 turbidity, 155  
 water-related diseases, 143–144
- Water for life decade**, 143  
**Water supply/sanitation organizations**, 156–157
- Waxy casts**, 110  
**Wayson's stain**,  
 preparation, 406, 407  
 use of, 43–44, 198
- WBC differential count**, 323–329  
**WBC differential counter**, 324  
**WBC diluting fluid**, 314, 402,  
 407  
**WBC total count**, 313–317  
**Weak antigen D**, 364  
**Weil's disease**, 225

- Weil-Felix reaction**, 230  
**Westergren ESR method**,  
329–331  
**Westergren stand**, 329, 330  
**Wet preparations**, 35–36  
**White cells (leukocytes)**,  
basophils, 273, 288, 326  
differential count, 323–329  
disorders, 290–295  
eosinophils, 273, 287–288, 326  
leukocytosis, 290, 317  
leukopenia, 290, 317  
lymphocytes, 257–258, 273,  
289–290  
monocytes, 273, 288–289, 326  
neutrophils, 273, 286–287, 326  
reference ranges, 317, 325  
total count (WBC), 313–317  
urine, 108, 109  
**WHO Strategy for HIV testing**,  
259–260  
**Whole blood clotting time test**, 347  
**Whole blood control**, 270  
**Whooping cough**, 205  
**Widal test**, 185  
**Wire loop**, 55, 113  
**Wood's light**, 235  
**Wright's stain**, 323, 407  
**Wright's staining technique**, 323  
***Wuchereria bancrofti* in urine**,  
110  
**X and V factors**, 202–203, 204  
**Xanthochromic csf**, 117  
***Xenopsylla cheopis***, 197  
**Xylose lysine deoxycholate  
(XLD) agar**,  
preparation 407  
use of, 101, 179, 184, 188  
**Yaws**, 224  
**Yeast cells**, 32  
*Candida albicans*, 76, 92,  
243–244  
*Cryptococcus neoformans*,  
121–122, 124, 244  
*Malassezia furfur*, 238  
urine, 109, 110  
**Yellow fever virus**, 28  
***Yersinia enterocolitica***,  
199  
***Yersinia pestis***, 43–44, 74,  
**197–199**  
**Ziehl-Neelsen staining**  
*M. tuberculosis*, 39–41  
*M. ulcerans*, 39–41  
*M. leprae*, 215–216  
*N. meningitis*, 121  
**Zip-Zone electrophoresis  
chamber**, 339  
**Zone diameters**, 141  
**Zones of inhibition**, 138–140, 141  
**Zoonoses**, 25, 165, 225  
**Zygomycetes**, 246